

## iQpump1000 AC Drive Intelligent Pump Controller User Manual

Type: CIMR-PW□A□□□

Models: 200 V Class: 3/4 to 175 HP ND  
400 V Class: 3/4 to 1000 HP ND  
600 V Class: 2 to 250 HP ND

To properly use the product, read this manual thoroughly and retain for easy reference, inspection, and maintenance. Ensure the end user receives this manual.

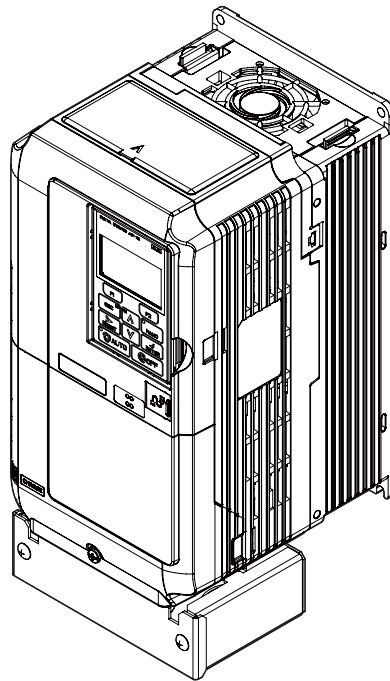

**iQPUMP<sup>®</sup>1000**  
Intelligent Pump Controller

MANUAL NO. TOEP YAIP1W 01F  
PUBLISHED MARCH 2017  
REVISION <7>  
DRIVE SOFTWARE PRG: 8554

Receiving	1
Mechanical Installation	2
Electrical Installation	3
Start-Up Programming & Operation	4
Troubleshooting	5
Periodic Inspection & Maintenance	6
Peripheral Devices & Options	7
Specifications	A
Parameter List	B
MEMOBUS/Modbus Communications	C
Standards Compliance	D



---

## ◆ Simple Setup Procedure

This procedure is a supplement to other documentation supplied with this equipment and guides the user in properly wiring the iQpump and motor. It also shows the configuration for a simplex pump application.

**WARNING!** *Read and adhere to all safety messages contained in this manual prior to performing this procedure. When installing the system be sure to follow good wiring practices and all applicable codes. Ensure that the mounting of the various components are secure and that the environment, such as extreme dampness, poor ventilation etc. will not cause system degradation. Please read this cheat sheet and other documentation provided with the iQpump thoroughly before attempting any installation.*

The setup procedure begins on the next page.

## Step 1 iQpump Model Identification and Mounting

To make sure you received the correct model, it is essential to verify the iQpump nameplate with your order and make sure the iQpump has the correct rating so it can be used with your motor. Please check the nameplate information as shown in the example below.

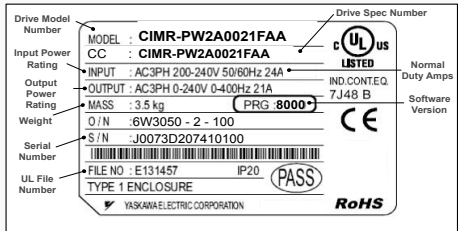

- Check that the available power will meet the input power requirements.
- Ensure that the output power from the iQpump is compatible with the motor requirements.
- In the case of systems with more than one iQpump, follow the above procedure for each iQpump and motor.

### Mounting the iQpump

The mounting of the iQpump is extremely important regarding environment and accessibility. Depending on your system, there are various models available and the mounting dimensions (footprint) may be different. Because the mounting procedure is fairly extensive, it is beyond the scope of this document; Refer to the iQpump1000 Quick Start Guide (Document No. TOEPYAIP1W01) received with the iQpump. **Section 2.2 Mechanical Installation.** Match the model that you received and follow the procedure described in the manual to ensure a safe and functional installation. In cases where the system has more than one iQpump, refer to the proper clearances required for adequate ventilation. Please pay particular attention to:

- The clearances to be maintained around the enclosure for adequate ventilation.
- The environmental specifications such as avoiding excessive dampness, extreme temperatures, chemical exposure, corrosive areas, etc. to avoid damage to the equipment and to maintain safety.

### Removing and Attaching the Terminal Cover

Improper removal of the iQpump terminal cover as well as front cover can cause extensive damage to the iQpump. To avoid damage to these items, please pay particular attention to the iQpump1000 Quick Start Guide TOEPYAIP1W01 Section 3.5 Removing and Attaching the Terminal Cover.

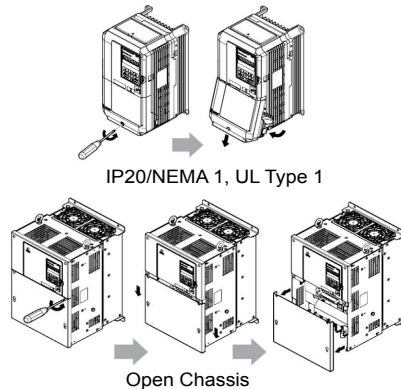

## Step 2 Connect Motor and Line Power

Fig.1 & 2 below show the electrical connections for the input power and motor terminals for various iQpump models. Select the proper diagram for the model you are installing (see Step 1). **WITH POWER OFF** make the appropriate connections. **Make sure to follow good wiring practices and all applicable codes. Ensure that the equipment is grounded properly as shown in fig. 1**

**DANGER; LETHAL VOLTAGES ARE PRESENT** - Before applying power to the iQpump, ensure that the terminal cover is fastened and all wiring connections are secure. After the power has been turned OFF, wait at least five minutes until the charge indicator extinguishes completely before touching any wiring, circuit boards or components.

**WARNING DO NOT CONNECT ANY OF THE FOLLOWING TERMINALS TO EARTH GROUND**

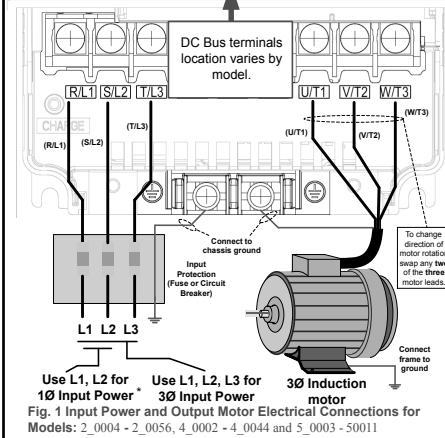

Fig. 1 Input Power and Output Motor Electrical Connections for Models: 2\_0004 - 2\_0056, 4\_0002 - 4\_0044 and 5\_0003 - 50011

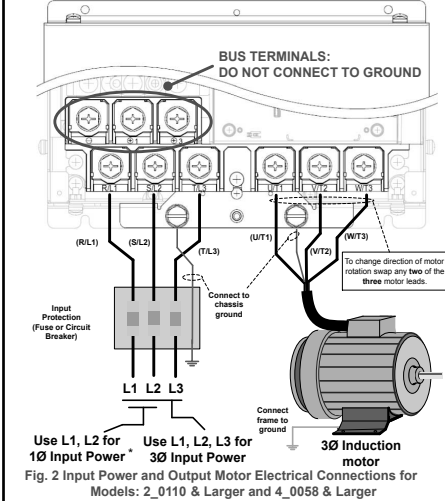

Fig. 2 Input Power and Output Motor Electrical Connections for Models: 2\_0110 & Larger and 4\_0058 & Larger

\* Make sure the iQpump has been properly sized for single phase input power. For best performance, the drive input supply voltage must be equal to or greater than the motor rated voltage.

## Step 3 Real-time Clock Setup

This step shows how to setup the iQpump real-time clock for first use.

Note: If clock is not set the drive can still be programmed and operated, but ALM light will flash every 30s and showing **Clock Not Set** message.

Power up the drive and set the real-time Clock. The real-time Clock setup screen will appear at first power up.

Press **F2** to set the clock.

Note: After the real-time clock is set the real-time clock setup screen will not show again unless parameter o4-17 is set to "Set".

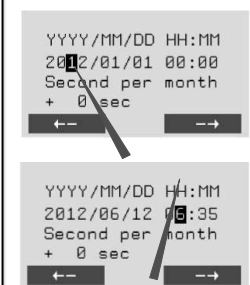
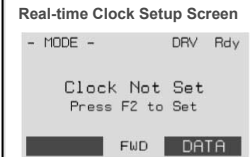

Use **F1** to move cursor to the left and **F2** to move cursor to the right  
 use **↑** **↓** to adjust.  
 When date and time are set press **ENTER** to save.

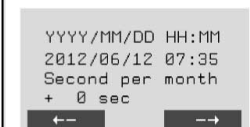

Example: Jun 12<sup>th</sup> 2012, 7:35am

Note: Do NOT adjust sec per month.

**Step 4**

**Selecting Start/Stop and Speed Method**

This step shows how to connect control wiring and feedback signal to the iQpump. Before making any control connections **MAKE SURE POWER TO THE iQpump IS TURNED OFF!** Next remove the terminal cover to gain access to the control terminals. (Step 1.)

**SELECT START / STOP CONTROL METHOD b1-02**

The iQpump is **DEFAULT SETUP TO START /STOP FROM THE KEYPAD** (digital operator). If this is the preferred start/stop method then continue to the feedback signal connection section. Please refer to the wiring diagram below to start/stop the iQpump using an external switch or contact.

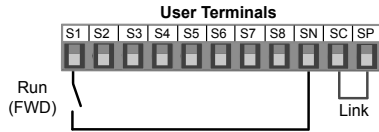

**Wiring Diagram: 2-Wire Control**  
Use for maintained contacts

Note: 3<sup>rd</sup> row of terminal board is shown here.

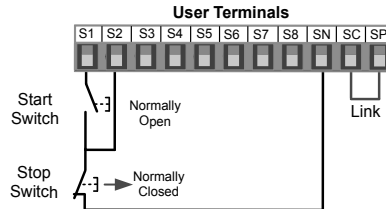

**Wiring Diagram: 3-Wire Control**  
Use for momentary contacts  
To use 3-Wire Control first Initialize the iQpump using parameter A1-03 = 3330 (Refer to the Quick Start Guide TOEP YAIP 1W 01)

**FEEDBACK SIGNAL WIRING (TRANSDUCER)**

Note: 2<sup>nd</sup> row of terminal board is shown here.

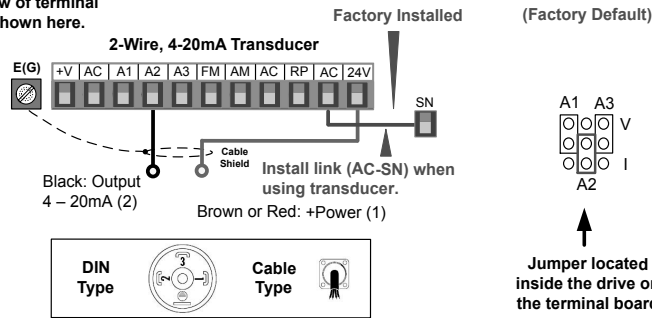

For use with 2-Wire, 4 – 20mA Transducer (Factory Default)

Note: 2<sup>nd</sup> row of terminal board is shown here.

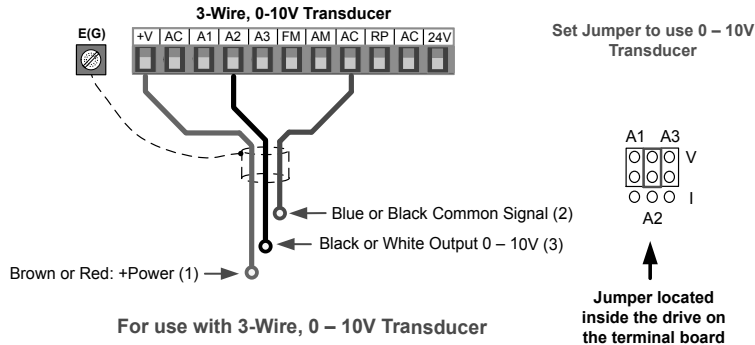

For use with 3-Wire, 0 – 10V Transducer

**Important Note:** Signal colors and numbering may vary depending on feedback device used, please consult feedback device manual.

NOTE: It is beyond the scope of this document to program the iQpump drive for network communication control. Please refer to the refer to the iQpump1000 Quick Start Guide (Document No. TOEPYAIP1W01) for this selection.

## Step 5

### Changing Parameters and Monitoring the iQpump

This step shows how to access and modify an iQpump parameter as well as how to monitor iQpump signals such as output frequency and motor current.

Make sure all protective covers have been re-attached and power is turned on. **DO NOT RUN THE MOTOR.**

#### Access Parameter Menu and Change Parameter Value

Press **▲** two times until the digital operator shows the parameter menu.

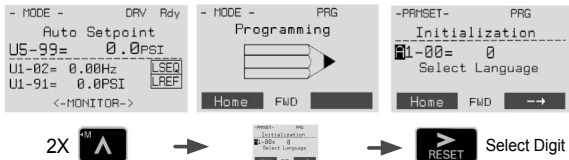

2X **▲** → **RESET** Select Digit



Inc./Dec. Selection → Go to Next Digit → Inc./Dec. Selection

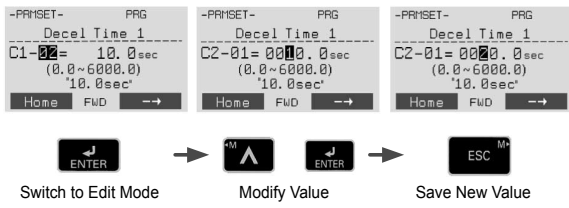

Switch to Edit Mode → Modify Value → Save New Value

Hold **ESC** button for 3 sec. to go back to the main menu.

#### Monitor Motor Frequency and Motor Current

iQpump Digital Operator power-up state → **F2**

Output Frequency and Transducer Feedback can be monitored simultaneously. Use **F2** and **F2** to select monitor signals.

Press **ESC** simultaneously shows the monitor menu.

Press **ESC** to access monitor menu.

Use **F2** to select monitor.

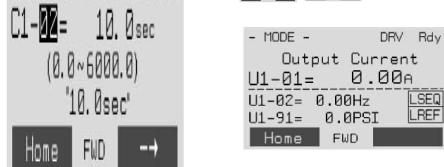

Please refer to the iQpump Quick Start Manual, (Document No. TOEP YAIP1W 01) on how to access other drive monitors.

## Step 6

### Application Setup

This step shows how to configure the iQpump for a dedicated pump application.

Make sure all protective covers have been reattached and power is turned on. **DO NOT RUN THE MOTOR**

Available iQpump Application Macros:

- 6008 Constant Pressure Mode (PSI) ← **Default**
  - 6009 Pump Down Level Mode (Ft)
  - 6010 Geothermal Mode
  - 6011 VTC Pressure Control Mode
  - 6012 VTC Pivot Panel Mode
  - 6013 Advanced Pressure Control Mode
  - 6014 Pivot Panel Submersible Mode
  - 7770 General Purpose Mode
  - 7771 General Purpose Submersible Motor Mode
- The factory default is setup for constant pressure PSI, only change if application different.

#### Select Application

Press **▲** two times until the digital operator shows the parameter menu.

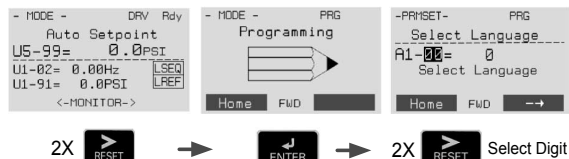

2X **▲** → **ENTER** → 2X **▲** Select Digit

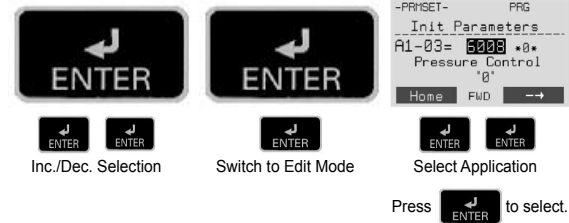

Inc./Dec. Selection → Switch to Edit Mode → Select Application → Press **ENTER** to select.

#### Enter Application Parameters

Hold **▼** button for 3 sec. to go back to the main menu.

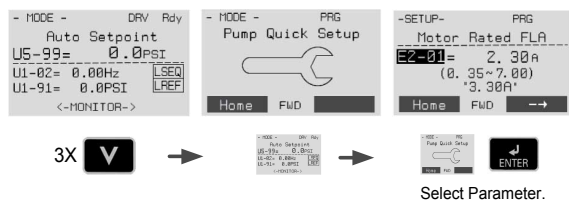

3X **▼** → **ENTER** Select Parameter.

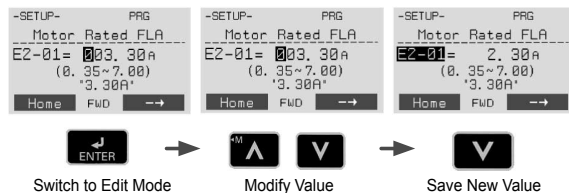



Switch to Edit Mode → Modify Value → Save New Value

#### Go Back to Main Menu

Hold **Wrench** button for 3 sec. to go back to the main menu.

**Step**  
**7**

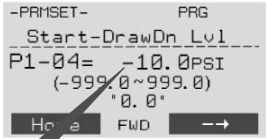
**iQpump Quick Setup Parameter Overview (Simplex)**

Parameter	Value	Description	Reference	Comments
A1-06	Dependent on Initialization Mode	Application Selected	Displays selected applications, see Step 6.	Read-only cannot be modified
E2-01	Drive Size Dependent	Motor Rated Current	Set to the motor nameplate full load amps.	For submersible motors use service factor amps (SFA).
E2-04	2	Number of Motor Poles	Number of motor poles is used to show the correct motor RPM on the display Enter '4' for an 1800 RPM motor and '2' for a 3600 RPM motor.	Confirm number of poles 2 Pole Motor = 3600 RPM 4 Pole Motor = 1800 RPM 6 Pole Motor = 1200 RPM 8 Pole Motor = 900 RPM
P1-03	145	Feedback Device Scaling	System Scaling: Enter feedback device maximum: Example: Enter 200 for pressure transducer with a maximum of 200 PSI at 20mA.	Confirm feedback device scaling. <b>(See Illustration 1)</b>
Q1-01	0	Setpoint 1	Set System Setpoint	<b>Set to system pressure</b>
P1-04	0.0 PSI	Start / Drawn Down Level	<p>When the iQpump is turned <b>On</b> and the feedback signal level (transducer) falls below this level, the pump system will start after the time specified in P1-05 (default 1 sec).</p> <p><b>Programming the Start Level as an Absolute Value.</b> Start / Draw Down Level has to programmed to a positive value in order for the Start / Draw Down Level to be an absolute value. Example: Start / Draw Down Level P1-04 set to <b>50 PSI</b> and delay time P1-05 set to <b>5 sec</b>. Pump system will start when the pressure drops below 50 PSI for 5 sec.</p> <p><b>Programming the Start Level as a Delta Level from the System Setpoint</b> Start / Draw Down Level has to programmed to a negative value in order for the Start Level to be a delta value from the setpoint.</p> <p>Example: Start / Draw Down Level P1-04 set to <b>-10 PSI</b> with a system setpoint of <b>50 PSI</b> and a delay time P1-05 set to <b>5 sec</b>. Pump system will start when the pressure drops below 40 PSI (50 - 10) for 5 sec.</p>	<p>It is mandatory to program the Start / Draw Down Level in order to use the sleep function. <b>(See Illustration 2 and 3)</b></p>  <p>Use   to change the sign.</p>
P1-06	40.0 Hz	Minimum Pump Speed	Minimum speed (Hz) the pump motor has to operate at. <b>Example:</b> Base pump motor speed is 3600 RPM, minimum speed is 2400 RPM. Set minimum pump frequency to 40.0 Hz. (2400 ÷ 3600 x 60 Hz = 40 Hz)	Minimum pump frequency should be set to a value where the pump enters a no-flow condition.
P4-10	0 Disabled	Auto Mode Operator Run Power Down Storage	Stores the run status in the Auto mode when operating from digital operator (b1-02=0). 0: Disabled 1: Enabled	Recommended for use when Start/Stop command is from the keypad. <b>(See Step 9)</b>
P5-04	1 Enabled	Hand Key Enable / Disable	Enables or disables the Hand Key on the digital operator. 0: Disabled 1: Enabled	Hand Key on keypad. <b>(See Step 10)</b>

**Step**  
**7**

**iQpump Factory Defaults Overview**  
(adjust certain settings specific to the application)

No.	Value	Description	Reference	Comments
b5-03	3.0 sec.	PI Integral Time	Decrease integral time to make iQpump more responsive.	<b>Caution:</b> can cause instability if value is too low.
b5-12	2 (Fault)	PI Feedback Reference Missing Detection Selection	Select what to do when the feedback device (transducer) fails or gets disconnected. 0: Disabled, continue running no message is displayed 1: Alarm, show warning on the keypad when the feedback device fails or is disconnected 2: Fault, stop pump system when the feedback fails or is disconnected	<b>NOTE:</b> Disable parameter b5-12 if no transducer is installed.
C1-01	20.0 sec. <b>See Note</b>	Acceleration Time 1	Time it takes to accelerate the pump motor from zero to maximum speed. <b>NOTE:</b> Factory default with Thrust Mode enabled is 12.0 sec, 20.0 sec when disabled.	Adjusted depending on system performance
C1-02	10.0 sec. <b>See Note</b>	Deceleration Time 1	Time it takes to decelerate the pump motor from maximum speed to zero. <b>NOTE:</b> Factory default with Thrust Mode enabled is 5.0 sec, 10.0 sec when disabled.	
L5-01	5	Number of Restart Attempts	Determines the number of times iQpump will perform an automatic restart on the faults listed in the comments column.  iQpump System Protection Faults that can be setup to restart are Low Level Feedback, High Level Feedback, Transducer Loss, Not Maintaining Setpoint, Loss of Prime, Pump Over Cycle. Refer to parameters P4-07 and P4-08. The number of restart attempts is set by L5-01.	<input type="checkbox"/> Overcurrent <input type="checkbox"/> Ground Fault <input type="checkbox"/> Output Phase Loss <input type="checkbox"/> Input Phase Loss <input type="checkbox"/> iQpump Overload <input type="checkbox"/> Motor Overload <input type="checkbox"/> Overtorque <input type="checkbox"/> DC Bus Fuse Blown <input type="checkbox"/> DC Bus Undervoltage <input type="checkbox"/> DC Bus Overvoltage <input type="checkbox"/> Overheat
L5-03	20 sec.	Maximum Restart Time After Fault	If the restart fails (or is not attempted due to a continuing fault condition) iQpump waits the Maximum Restart Time After Fault, before attempting another restart.	
P1-06	40.0 Hz	Minimum Pump Frequency	Minimum speed (Hz) the pump motor has to operate at. Example: Base pump motor speed is 3600 RPM, minimum speed is 2400 RPM. Set minimum pump frequency to 40.0 Hz. (2400 + 3600 x 60 Hz = 40 Hz)	P1-06 should be set to the level where the pump can produce the minimum pressure even at zero flow.
P2-03	5 sec.	Sleep Delay Time	Time it takes before the pump system goes to sleep when the selected signal level (P2-01) falls below the specified sleep level (P2-02)	Adjust according to system requirements.
P4-12	30.0 Hz	Thrust Bearing Frequency	Sets the frequency reference used when the thrust bearing function is active. A value of 0 disables this function.	Primarily used for submersible pumps. Program P4-12 = 0.0 Hz to disable function when iQpump is used with a centrifugal pump.
P4-17	0.2 Min	Utility Start Delay	When utility power is restored and P4-10 is enabled (1), iQpump waits the time specified in P4-11 before auto operation becomes active.	Note: Only active when P4-10 is enabled (1) and operation (start/stop) is from the digital operator.

**1 SYSTEM FEEDBACK UNIT / FEEDBACK DEVICE SCALING**  
P1-02 Feedback Unit

0: Inch of Water	8: Bar
1: PSI	9: Pascal
2: GPM	10: Degrees Celsius
3: Degrees Fahrenheit	11: Meter
4: CFM	12: Feet
5: CMH	13: Liters per Minute
6: Liters / Hr	14: cm per Minute
7: Liters/Sec	15: Inch Hg
	25: No Unit

P1-03 = 200.0 PSI Feedback Scaling

↓  
**Feedback Maximum**

**2 START / DRAW DOWN LEVEL**  
Example: Absolute Level (Positive Start Level)

Pressure (PSI) vs Time

System Setpoint (Example 150.0 PSI)  
Feedback Scaling (P1-03) (Example 200.0 PSI)  
System Units (P1-02) (Example PSI)  
Start / Draw Down Level (P1-04) (Example 100.0 PSI)

**START / DRAW DOWN LEVEL**  
Example: Delta Level (Negative Start Level)

Pressure (PSI) vs Time

System Setpoint (Example 150.0 PSI)  
Feedback Scaling (P1-03) (Example 200.0 PSI)  
System Units (P1-02) (Example PSI)  
Start / Draw Down Level (P1-04) (Example -50.0 PSI, (150.0 - 50.0))



**Step 7** iQpump Factory Defaults Overview  
(adjust certain settings specific to the application)

### 3 SLEEP MODE (Example)

**SYSTEM GOES TO SLEEP WHEN PUMP MOTOR SPEED DROPS BELOW 40 Hz (2400 RPM for 3600 RPM Motor).**

Output Frequency (pump motor speed)

Sleep Delay Time (P2-03) (Example 5.0 sec.)

Minimum Speed P1-06 (Example 40.0 Hz)

Ramp or Coast to Stop, b1-02

Pump Running | Go to Sleep | WAIT FOR PRESSURE TO FALL BELOW START / DRAW DOWN LEVEL (P1-04)

### 4 PUMP SYSTEM FAULT SETUP

The iQpump can display a 'Setpoint Not Met' fault when the iQpump is unable to maintain the programmed system setpoint due a problem with the pump system. Set P1-15 to the maximum allowed difference between setpoint and feedback level.

FEEDBACK SIGNAL

SETPOINT

Setpoint -LOP Tim

P1-15 Max Setpoint Diff

P1-16

SET-POINT NOT MET

### 5 LOW/HIGH FEEDBACK LEVEL DETECTION

iQpump continuously monitors the system feedback signal. To display a 'Low Feedback' fault set the low feedback level parameter P1-08 to the minimum feedback level allowed for your system and to display a 'High Feedback' fault set the high feedback level parameter P1-11 to the maximum feedback level allowed.

### 6 PRE-CHARGE OPERATION

This function is used when the pump system requires to be pre-charged before normal operation. Upon start the iQpump will run at a fixed speed for a specified time or until the feedback signal reaches a programmed level after which it will switch to auto mode operation.

Pre-Charge Lvl. P4-01

Pre-Charge Freq. P4-02

0 Hz

Output Frequency

Feedback

Pre-Charge Completed

Auto Operation

P4-01 Pre-Charge Level: Specified feedback level to stop pre-charge operation  
P4-02 Pre-Charge Frequency: Set desired pre-charge speed  
P4-03 Pre-Charge Time: Specified maximum pre-charge operation time

### 7 THRUST BEARING - SUBMERSIBLE MOTORS

When using a submersible motor in combination with the iQpump, it is recommended to use the **Thrust Bearing** function to prevent excess motor wear. To enable this function, enter the minimum motor frequency in parameter P4-11. Example: Minimum motor speed 1800 RPM,  $1800 \text{ RPM} \div 3600 \text{ RPM} \times 60.0 \text{ Hz} = 30.0 \text{ Hz}$

Thrust Acceleration Time P4-11 (Example 1.0 sec.)  
Thrust Bearing Frequency P4-12 (Example 30.0 Hz)

Output Frequency

Turn Off Thrust Bearing Function (Output Frequency Reached)

C1-01 Acceleration Time

P4-11 Thrust Time

Output Frequency

Thrust Bearing | Auto/Hand Operation

### 8 AUTO OPERATION – POWER DOWN STORAGE

Allows iQpump to automatically start after power failure when operated from keypad / digital operator. This function is recommended for use when operating the iQpump in remote / unmanned areas. Use parameter P4-10 to enable.

⚠ When the iQpump is powered down while running, an internal run command will automatically be initiated upon power -up.

## Step 8 Pump Rotation and Feedback Signal Check

In this step the motor is checked for proper direction and operation. This test is to be performed solely from the digital operator. Apply power to the iQpump after all the electrical connections have been made and protective covers have been re-attached. At this point, **DO NOT RUN THE MOTOR**, the Digital Operator should display as shown in Fig. 3.

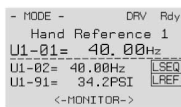

Fig. 3: Digital Operator

Auto Mode Off

### Motor Rotation Test

Next, push **HAND** on the Digital Operator; the display should read



and the **HAND** LED should be **ON**.

The motor should now be operating at in the correct direction of pump.

Push **OFF** on the Digital Operator; the display should read as in Fig. 3.

Press **ENTER** to access Hand Speed. Use **UP**, **DOWN**, **RESET** to change Hand Speed value. Press **ENTER** to save value.

If the direction is not correct, then power down the iQpump and follow

Instructions below.

### ! DANGER

After the power has been turned OFF, wait at least five minutes until the charge indicator extinguishes completely before touching any wiring, circuit boards or components.



Digital Operator turned off.

Use precaution, and refer to Fig.1 or 2, swap any **two** of the **three** output leads to the motor (U/T1, V/T2 and W/T3). After the wiring change, repeat **Step 8** and recheck motor direction.

## FEEDBACK SIGNAL CHECK

Verify feedback on display (show keypad) matches mechanical pressure gauge.

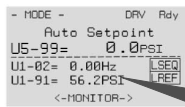

Refer to parameter P1-02 and P1-03, if the feedback device scaling or system units are incorrect.

FEEDBACK SIGNAL LEVEL

## Step 9 Auto Mode Operation

### AUTO MODE

The iQpump can be operated in AUTO mode when the following actions have been performed:

- All parameters are programmed
- Motor direction has been checked
- Auto Mode: Reference source selected in parameter b1-01 (See step 3)
- Auto Mode: Run source selected in parameter b1-02 (See Step 3)



Fig. 4: Digital Operator

LED is blinking when AUTO mode is active but AUTO Run Command is not active.

PRESS AUTO BUTTON

PRESS TO TURN OFF

Press the **AUTO** button to put the iQpump into AUTO mode.

In AUTO mode the iQpump is capable of starting or stopping based on the Run Source Selection setting parameter b1-02. (See Step 3 Select Start/Stop Control Method) The setpoint used in AUTO mode is based on the Reference Source Selection setting parameter b1-01. (See Step 3 Select Speed Method)

### SET SYSTEM SETPOINT

Next, press **ENTER** to access or modify the system setpoint that was entered using parameter Q1-01 System Setpoint in the iQpump Quick Setup Menu

Use **RESET** to select the digit and **UP**, **DOWN** to change the system setpoint.

Next press **ENTER** to store setpoint and press **F1** to return to the main operation menu.

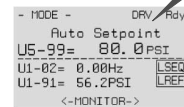

Next, press the **AUTO** button to start the iQpump.

Example: 80 PSI



iQpump automatically starts in Auto Mode when the feedback signal level falls below the programmed level in parameter P1-04 for the specified time in P1-05.

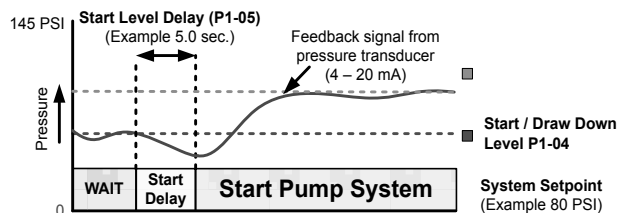

Refer to Illustration 2 on Page 3 of 4 for additional information on the Start Level Function.

## Step 10 Hand Mode Operation

### HAND MODE

The iQpump can be operated in HAND mode when the following actions have been performed:

- All parameters are programmed
- Motor direction has been checked

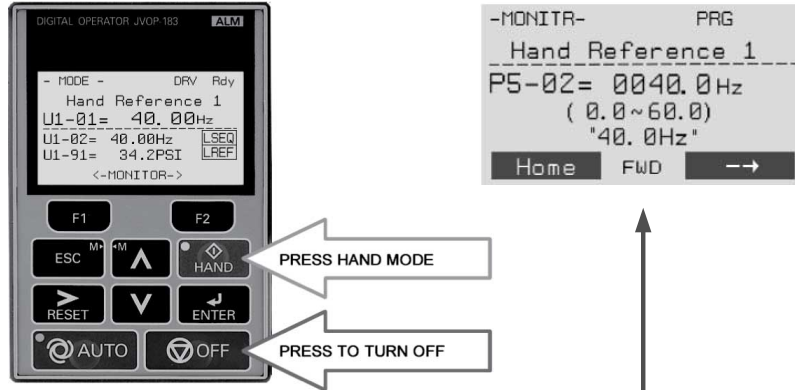

Press to access Hand Speed. Use to change Hand Speed value. Press to save value.

#### Hand Speed from Analog Input (0 – 10V)

Set parameter P5-01 'Hand Mode Ref.' to '0' to adjust the hand mode reference from an external 0 – 10V signal connected to terminal A1 and AC.

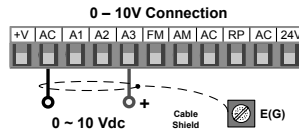

### Sleep and Anti-No-Flow (ANF) Detection (P2-23, P2-24, P2-25)

**NOTE:** Before adjusting Anti-No-Flow operation ensure your system is regulating satisfactory while operating under normal running conditions.

If stable continue to Step 1 to verify no-flow/sleep operation. If unstable turn off the Anti-No-Flow function (P2-23 = 0.00%) and adjust the PI control parameters b5-02 and b5-03 to stabilize pump system. Refer to iQpump Quick Start Guide (Document No. TOEP YAIP 1W 01) for additional information. Once the system is stable, re-enable the Anti-No-Flow function by setting P2-23 to 0.40% and continue to Step 1 to verify no-flow/sleep operation.

**Step 1:** Verify system holds pressure by creating a no-flow situation (e.g. close off discharge valve).

**Step 2:** Press OFF button on the digital operator, wait 1 min. until system stabilizes and verify system pressure feedback U1-91. If the pressure drops more than 3 PSI (U1-91) adjust P2-25 to the actual delta pressure drop plus 1 PSI.

**Example:** Setpoint is 80 PSI, pressure feedback U1-91 shows 76 PSI, P2-25 should be 4 + 1 or 5 PSI.

**Note:** This value should always be more than your start level (P1-04). If not, the system pressure is not holding and this needs to be corrected, or the pump system will continue to cycle on and off.

**Step 3:** Run system in normal automatic operation with flow. Next check monitor U1-99 "ANF Timer" and verify that the value is incrementing and resetting back to zero continuously. If the value holds at 10 sec. (P2-24) increase P2-24 "Anti-No-Flow Detection Time" by increments of 5 sec. Repeat Step 3 each time P2-24 is adjusted.

**Step 4:** Create a no-flow situation (e.g. close discharge valve) and monitor that U1-99 "ANF Timer" increments and holds at P2-24 time (value set in Step 3). Once the Anti-No-Flow timer expires the speed will reduce gradually until it reaches minimum pump speed (P1-06) where it will hold for 5 sec. (P2-03) before going to sleep.

**Step 5:** Run system in normal automatic operation and verify sleep and wake-up operation until system performs satisfactory.

---

**This Page Intentionally Blank**

# Table of Contents

<b>SIMPLE SETUP PROCEDURE</b> .....	<b>3</b>
<b>i. PREFACE &amp; GENERAL SAFETY</b> .....	<b>21</b>
<b>i.1 Preface</b> .....	<b>22</b>
Applicable Documentation.....	22
Symbols.....	22
Terms and Abbreviations .....	22
Trademarks .....	23
<b>i.2 General Safety</b> .....	<b>24</b>
Supplemental Safety Information .....	24
Safety Messages.....	25
General Application Precautions .....	26
Motor Application Precautions.....	28
Drive Label Warning Example.....	30
Warranty Information.....	30
<b>1. RECEIVING</b> .....	<b>31</b>
<b>1.1 Model Number and Nameplate Check</b> .....	<b>32</b>
Nameplate.....	32
<b>2. MECHANICAL INSTALLATION</b> .....	<b>35</b>
<b>2.1 Mechanical Installation</b> .....	<b>36</b>
Installation Environment.....	36
Installation Orientation and Spacing.....	36
Instructions on Installation Using the Eye Bolts .....	38
HOA Keypad Remote Usage .....	40
Exterior and Mounting Dimensions .....	43
<b>2.2 Flange Type Enclosure (NEMA 12 Backside) Dimensions &amp; Heat Loss</b> .....	<b>53</b>
Flange Type Models 2A0004 to 2A0012, 4A0002 to 4A0005, and 5A0003 and 5A0004 .....	53
Flange Type Models 2A0018 and 2A0021, 4A0007 to 4A0011, and 5A0006 and 5A0009 .....	56
Flange Type Models 2A0030 and 2A0040, 4A0018 and 4A0023, and 5A0011.....	59
Flange Type Model 4A0031 .....	62
Flange Type Models 2A0056, 4A0038, and 5A0017 and 5A0022 .....	64
Flange Type Models 2A0069 and 2A0081, 4A0044, and 5A0027 and 5A0032.....	67
Flange Type Models 2A0110 and 4A0058.....	70
Flange Type Models 2A0138, 4A0072, and 5A0041 and 5A0052 .....	72
Flange Type Models 4A0088 and 4A0103.....	74
Flange Type Models 2A0169 and 2A0211, 4A0139 and 4A0165, and 5A0062 to 5A0099 .....	76

Flange Type Models 2A0250 and 2A0312, 4A0208, and 5A0125 and 5A0145.....	79
Flange Type Models 2A0360 and 2A0415, 4A0250 to 4A0362, and 5A0192 and 5A0242 .....	81
Flange Type Model 4A0414 .....	84
Flange Type Models 4A0515 and 4A0675 .....	86
Flange Type Models 4A0930 and 4A1200 .....	88
<b>3. ELECTRICAL INSTALLATION .....</b>	<b>91</b>
<b>3.1 Standard Connection Diagram.....</b>	<b>92</b>
<b>3.2 Main Circuit Connection Diagram.....</b>	<b>95</b>
Three-Phase 200 V Class Models 2A0004 to 2A0081	
Three-Phase 400 V Class Models 4A0002 to 4A0044	
Three-Phase 600 V Class Models 5A0003 to 5A0032 .....	95
Three-Phase 200 V Class Models 2A0110, 2A0138	
Three-Phase 400 V Class Models 4A0058, 4A0072	
Three-Phase 600 V Class Models 5A0041, 5A0052 .....	95
Three-Phase 200 V Class Models 2A0169 to 2A0211	
Three-Phase 400 V Class Models 4A0088 to 4A0139	
Three-Phase 600 V Class Models 5A0062 to 5A0099 .....	96
Three-Phase 200 V Class Models 2A0250 to 2A0415	
Three-Phase 400 V Class Models 4A0165 to 4A0675	
Three-Phase 600 V Class Models 5A0125 to 5A0242 .....	96
Three-Phase 400 V Class Models 4A0930, 4A1200.....	97
Single-Phase Connections .....	97
12-Phase Rectification .....	97
<b>3.3 Terminal Block Configuration .....</b>	<b>99</b>
<b>3.4 Terminal Cover .....</b>	<b>101</b>
Models 2A0004 to 2A0081, 4A0002 to 4A0044, 5A0003 to 5A0032 (IP20/NEMA 1, UL Type 1 Enclosure).....	101
Models 2A0110 to 2A0250, 4A0208 to 4A1200, and 5A0125 to 5A0242 (IP00/Open Type Enclosure).....	102
<b>3.5 HOA Keypad and Front Cover.....</b>	<b>103</b>
Removing/Reattaching the HOA Keypad .....	103
Removing/Reattaching the Front Cover .....	103
<b>3.6 Top Protective Cover .....</b>	<b>106</b>
Removing the Top Protective Cover .....	106
Reattaching the Top Protective Cover .....	106
<b>3.7 Main Circuit Wiring.....</b>	<b>107</b>
Factory Recommended Branch Circuit Protection .....	107
Main Circuit Terminal Functions.....	107
Protecting Main Circuit Terminals .....	109
Main Circuit Wire Gauges and Tightening Torques .....	110
Main Circuit Terminal and Motor Wiring .....	118
<b>3.8 Control Circuit Wiring .....</b>	<b>120</b>
Control Circuit Terminal Block Functions .....	120
Terminal Configuration .....	122
Wiring the Control Circuit Terminal .....	123
<b>3.9 Control I/O Connections .....</b>	<b>125</b>
Sinking/Sourcing Mode for Digital Inputs .....	125
Terminals A1, A2, and A3 Input Signal Selection.....	126
Terminal AM/FM Signal Selection .....	129

3.10	Connect to a PC.....	130
<b>4.</b>	<b>START-UP PROGRAMMING &amp; OPERATION.....</b>	<b>131</b>
4.1	<b>Drive Start-Up Preparation .....</b>	<b>132</b>
	Start-Up Checklist .....	132
4.2	<b>Powering Up the Drive .....</b>	<b>134</b>
	Setting the Real Time Clock.....	134
4.3	<b>Application Selection .....</b>	<b>138</b>
4.4	<b>Using the HOA Keypad .....</b>	<b>139</b>
	HOA Keypad Keys and Displays.....	139
	LCD Display .....	140
	ALARM (ALM) LED Displays.....	141
	AUTO LED and HAND LED Indications .....	141
	Menu Structure for HOA Keypad.....	143
	Changing Parameter Settings or Values .....	144
4.5	<b>Pump Application Presets .....</b>	<b>146</b>
	Modified Parameters Depending on A1-03 Setting .....	146
	Pump Quick Setup Menu Depending on A1-06 Setting .....	148
	Parameters Set Depending on A1-08 Setting .....	148
	Parameters Displayed Depending on A1-08 Setting.....	149
4.6	<b>iQpump Presets and Functions .....</b>	<b>150</b>
	Pump Down Level Control Application Preset.....	150
	Suction Control via Constant Pressure w/Well Draw Down .....	152
	Geothermal Mode Application Preset.....	154
	General Purpose Mode Application Preset .....	160
	Well Draw Down Control Application Preset .....	162
	Low City or Low Suction Inlet Pressure.....	165
	Water Level / Suction Pressure Control .....	167
	Delta Data Entry .....	168
	Current Limit.....	169
	Vertical Turbine Controller (VTC).....	170
	Pre-Charge Function with One Lag Pump .....	173
	Setpoint Boost after Lag Pump De-staging .....	176
	Frequency Reduction after Lag Pump Staging .....	177
	Using the DO-A3 Option for Additional Lag Pumps .....	178
	MEMOBUS Multiplexing Setup .....	179
	MEMOBUS Multiplexing Application Examples .....	184
	MEMOBUS Multiplexing Stop History .....	187
	MEMOBUS Multiplexing Speed Follower Deceleration Time Switchover.....	188
	MEMOBUS Multiplexing System-wide Parameter Entry .....	191
	De-Scale/De-Ragging .....	194
	2-Motor Contactor Alternation .....	196
	Flow Rate Limiter .....	198
	Multi-function Digital Input On/Off Time Delay .....	203
	PI Auxiliary Control.....	204
	Hybrid Sequence Control .....	208
	Differential Level Detection .....	209
4.7	<b>Basic iQpump Setup and Application Preset Parameters.....</b>	<b>210</b>
4.8	<b>Test Run with No Load.....</b>	<b>246</b>
	No-Load Operation Test Run .....	246

4.9	<b>Test Run with Load Connected</b> .....	<b>247</b>
	Test Run with the Load Connected.....	247
<b>5.</b>	<b>TROUBLESHOOTING</b> .....	<b>249</b>
5.1	<b>Drive Alarms, Faults, Errors, and Messages</b> .....	<b>250</b>
	Types of Alarms, Faults, and Errors.....	250
5.2	<b>Fault Detection</b> .....	<b>251</b>
	Fault Displays, Causes, and Possible Solutions .....	251
5.3	<b>Alarm Detection</b> .....	<b>270</b>
	Alarm Codes, Causes, and Possible Solutions .....	270
5.4	<b>Operator Programming Errors</b> .....	<b>285</b>
	Operator Programming Error Codes, Causes, and Possible Solutions.....	285
5.5	<b>Auto-Tuning Fault Detection</b> .....	<b>290</b>
	Auto-Tuning Codes, Causes, and Possible Solutions.....	290
5.6	<b>Copy Function Related Displays</b> .....	<b>293</b>
	Tasks, Errors, and Troubleshooting .....	293
5.7	<b>HOA Keypad Display Messages</b> .....	<b>295</b>
	Fault Reset Methods .....	296
5.8	<b>Auto-Tuning</b> .....	<b>297</b>
	Types of Auto-Tuning .....	297
	Auto-Tuning Interruption and Fault Codes .....	298
	Auto-Tuning Operation Example .....	298
<b>6.</b>	<b>PERIODIC INSPECTION &amp; MAINTENANCE</b> .....	<b>301</b>
6.1	<b>Inspection</b> .....	<b>302</b>
	Recommended Periodic Inspection.....	302
6.2	<b>Periodic Maintenance</b> .....	<b>304</b>
	Replacement Parts.....	304
6.3	<b>Drive Replacement</b> .....	<b>306</b>
	Replacing the Drive .....	306
<b>7.</b>	<b>PERIPHERAL DEVICES &amp; OPTIONS</b> .....	<b>309</b>
7.1	<b>Option Card Installation</b> .....	<b>310</b>
	Prior to Installing the Option .....	310
	Communication Option Installation Example.....	311
<b>A.</b>	<b>SPECIFICATIONS</b> .....	<b>315</b>
A.1	<b>Power Ratings</b> .....	<b>316</b>
	Three-Phase 200 V Class Drive Models 2A0004 to 2A0030 .....	316
	Three-Phase 200 V Class Drive Models 2A0040 to 2A0211 .....	317
	Three-Phase 200 V Class Drive Models 2A0250 to 2A0415 .....	318
	Three-Phase 400 V Class Drive Models 4A0002 to 4A0031 .....	319
	Three-Phase 400 V Class Drive Models 4A0038 to 4A0165 .....	320
	Three-Phase 400 V Class Drive Models 4A0208 to 4A1200 .....	321
	Three-Phase 600 V Class Drive Models 5A0003 to 5A0032 .....	322
	Three-Phase 600 V Class Drive Models 5A0041 to 5A0099 .....	323
	Three-Phase 600 V Class Drive Models 5A0125 to 5A0242 .....	324



<b>A.2 Drive Specifications .....</b>	<b>325</b>
<b>A.3 Drive Watt Loss Data .....</b>	<b>327</b>
<b>A.4 Drive Derating Data .....</b>	<b>329</b>
Single-Phase Derating .....	329
Temperature Derating .....	348
Altitude Derating.....	348
<b>B. PARAMETER LIST .....</b>	<b>349</b>
<b>B.1 Understanding Parameter Descriptions.....</b>	<b>350</b>
Control Modes, Symbols, and Terms .....	350
Parameter Groups.....	350
<b>B.2 A: Initialization Parameters .....</b>	<b>351</b>
A1: Initialization .....	351
A2: User Parameters.....	352
<b>B.3 b: Application.....</b>	<b>353</b>
b1: Operation Mode Selection.....	353
b2: DC Injection Braking and Short Circuit Braking.....	354
b3: Speed Search.....	354
b4: Timer Function .....	355
b5: PID Control.....	355
b6: Dwell Function.....	357
b8: Energy Saving.....	358
<b>B.4 C: Tuning.....</b>	<b>359</b>
C1: Acceleration and Deceleration Times .....	359
C2: S-Curve Characteristics.....	359
C3: Slip Compensation.....	360
C4: Torque Compensation .....	360
C6: Carrier Frequency.....	361
<b>B.5 d: References.....</b>	<b>362</b>
d1: Frequency Reference.....	362
d2: Frequency Upper/Lower Limits .....	363
d3: Jump Frequency.....	363
d4: Frequency Reference Hold and Up/Down 2 Function.....	364
<b>B.6 E: Motor Parameters .....</b>	<b>365</b>
E1: V/f Pattern .....	365
E2: Motor 1 Parameters .....	366
<b>B.7 F: Options.....</b>	<b>368</b>
F4: Analog Monitor Card (AO-A3).....	368
F5: Digital Output Card (DO-A3) .....	368
F6, F7: Communication Option Card.....	369
<b>B.8 H Parameters: Multi-Function Terminals .....</b>	<b>373</b>
H1: Multi-Function Digital Inputs .....	373
H2: Multi-Function Digital Outputs.....	379
H3: Multi-Function Analog Inputs .....	383
H4: Analog Outputs.....	385
H5: MEMOBUS/Modbus Serial Communication .....	386
H6: Pulse Train Input.....	387
<b>B.9 L: Protection Function .....</b>	<b>388</b>
L1: Motor Protection .....	388

## Table of Contents

---

L2: Momentary Power Loss Ride-Thru.....	389
L3: Stall Prevention .....	390
L4: Speed Detection .....	391
L5: Fault Restart.....	392
L6: Torque Detection.....	393
L7: Torque Limit .....	394
L8: Drive Protection.....	394
<b>B.10 n: Special Adjustment.....</b>	<b>396</b>
n1: Hunting Prevention.....	396
n2: Speed Feedback Detection Control (AFR) Tuning.....	396
n3: High Slip Braking (HSB) and Overexcitation Braking.....	396
n6: Online Tuning.....	397
<b>B.11 o: Operator-Related Settings .....</b>	<b>398</b>
o1: HOA Keypad Display Selection.....	398
o2: HOA Keypad Keypad Functions.....	399
o3: Copy Function .....	400
o4: Maintenance Monitor Settings.....	400
<b>B.12 P: Pump Parameters .....</b>	<b>402</b>
P1: Pump Basic.....	402
P2: Pump Protection .....	405
P3: Contactor Multiplexing .....	406
P4: Pump Advanced.....	409
P5: Pump HAND Mode .....	412
P6: Flow Meter Setup.....	413
P7: Anti-Jam.....	416
P8: De-Scale / De-Ragging .....	417
P9: Network Options .....	418
<b>B.13 Q: PID Controller Parameters.....</b>	<b>422</b>
Q1: Preset Setpoint.....	422
Q2: Geothermal Mode Setup .....	422
Q3: Output Current Limit .....	423
Q4: Water Level Control.....	424
Q5: Suction Pressure Control.....	425
Q6: PI Auxiliary Control .....	427
<b>B.14 S: Special Application.....</b>	<b>431</b>
S1: Dynamic Noise Control Function .....	431
S2: Programmable Run Timers.....	431
S3: Secondary PI (PI2) Control .....	434
S6: Protection.....	435
<b>B.15 T: Motor Tuning .....</b>	<b>436</b>
T1: Induction Motor Auto-Tuning.....	436
<b>B.16 U: Monitors.....</b>	<b>437</b>
U1: Operation Status Monitors .....	437
U2: Fault Trace.....	440
U3: Fault History.....	442
U4: Maintenance Monitors .....	443
U5: PID Monitors .....	446
U6: Operation Status Monitors .....	447
U7: CASE Monitors .....	447
U9: Operation Status Monitors .....	447

<b>C. MEMOBUS/MODBUS COMMUNICATIONS</b> .....	<b>449</b>
<b>C.1 MEMOBUS/Modbus Configuration</b> .....	<b>450</b>
<b>C.2 Communication Specifications</b> .....	<b>451</b>
<b>C.3 Connecting to a Network</b> .....	<b>452</b>
Network Cable Connection.....	452
Wiring Diagram for Multiple Connections .....	453
Network Termination .....	454
<b>C.4 MEMOBUS/Modbus Setup Parameters</b> .....	<b>455</b>
MEMOBUS/Modbus Serial Communication.....	455
<b>C.5 Drive Operations by MEMOBUS/Modbus</b> .....	<b>459</b>
Observing the Drive Operation.....	459
Controlling the Drive.....	459
<b>C.6 Communications Timing</b> .....	<b>460</b>
Command Messages from Master to Drive.....	460
Response Messages from Drive to Master .....	460
<b>C.7 Message Format</b> .....	<b>461</b>
Message Content .....	461
Slave Address .....	461
Function Code.....	461
Data.....	461
Error Check .....	461
<b>C.8 Message Examples</b> .....	<b>463</b>
Reading Drive MEMOBUS/Modbus Register Contents .....	463
Loopback Test.....	463
Writing to Multiple Registers.....	464
<b>C.9 MEMOBUS/Modbus Data Table</b> .....	<b>465</b>
Command Data .....	465
Monitor Data.....	467
Broadcast Messages.....	479
Fault Trace Contents.....	479
Alarm Register Contents .....	481
<b>C.10 Enter Command</b> .....	<b>483</b>
Enter Command Types .....	483
Enter Command Settings when Upgrading the Drive.....	483
<b>C.11 Communication Errors</b> .....	<b>484</b>
MEMOBUS/Modbus Error Codes.....	484
Slave Not Responding.....	484
<b>C.12 Self-Diagnostics</b> .....	<b>485</b>
<b>D. STANDARDS COMPLIANCE</b> .....	<b>487</b>
<b>D.1 European Standards</b> .....	<b>488</b>
CE Low Voltage Directive Compliance.....	488
EMC Guidelines Compliance .....	490
<b>D.2 UL and CSA Standards</b> .....	<b>496</b>
UL Standards Compliance .....	496
CSA Standards Compliance.....	503
Drive Motor Overload Protection .....	503
Precautionary Notes on External Heatsink (IP00/Open Type Enclosure).....	504

**This Page Intentionally Blank**

# Preface & General Safety

---

This section provides safety messages pertinent to this product that, if not heeded, may result in fatality, personal injury, or equipment damage. Yaskawa is not responsible for the consequences of ignoring these instructions.

<b>i.1</b>	<b>PREFACE.....</b>	<b>22</b>
<b>i.2</b>	<b>GENERAL SAFETY.....</b>	<b>24</b>

## i.1 Preface

Yaskawa manufactures products used as components in a wide variety of industrial systems and equipment. The selection and application of Yaskawa products remain the responsibility of the equipment manufacturer or end user. Yaskawa accepts no responsibility for the way its products are incorporated into the final system design. Under no circumstances should any Yaskawa product be incorporated into any product or design as the exclusive or sole safety control. Without exception, all controls should be designed to detect faults dynamically and fail safely under all circumstances. All systems or equipment designed to incorporate a product manufactured by Yaskawa must be supplied to the end user with appropriate warnings and instructions as to the safe use and operation of that part. Any warnings provided by Yaskawa must be promptly provided to the end user. Yaskawa offers an express warranty only as to the quality of its products in conforming to standards and specifications published in the Yaskawa manual. **NO OTHER WARRANTY, EXPRESS OR IMPLIED, IS OFFERED.** Yaskawa assumes no liability for any personal injury, property damage, losses, or claims arising from misapplication of its products.

This manual is designed to ensure correct and suitable application of drives. Read this manual before attempting to install, operate, maintain, or inspect a drive and keep it in a safe, convenient location for future reference. Be sure you understand all precautions and safety information before attempting application.

### ◆ Applicable Documentation

The following manuals are available for iQpump1000 drives:

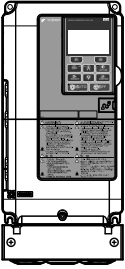
	iQpump1000 AC Drive Installation & Start-up Guide (TOEPYAIP1W02)
	Read this guide first. This guide is packaged together with the product and contains basic safety information, wiring information, and a list of models. Use this manual for basic settings and trial operation. The most recent version of this manual is available for download on our documentation website, <a href="http://www.yaskawa.com">www.yaskawa.com</a> .
	iQpump1000 AC Drive User Manual (TOEPYAIP1W01)
	This manual contains information required to install and wire the drive, and gives an overview of fault diagnostics, maintenance safety, and parameter settings. The most recent version of this manual is available for download on our documentation website, <a href="http://www.yaskawa.com">www.yaskawa.com</a> . Contact a Yaskawa representative to obtain a printed and bound version of the manual.
	iQpump1000 Simplex Quick Start Procedure (TM.iQp1000.01)
	This sheet is packaged together with the drive and contains a step-by-step guide to enable the user to properly wire the drive and motor. It also describes simplex pump application configuration.

### ◆ Symbols

**Note:** Indicates a supplement or precaution that does not cause drive damage.



Indicates a term or definition used in this manual.

### ◆ Terms and Abbreviations

- **Drive:** Yaskawa iQpump1000 Intelligent Pump Controller
- **BCD:** Binary Coded Decimal
- **H:** Hexadecimal Number Format
- **IGBT:** Insulated Gate Bipolar Transistor
- **kbps:** Kilobits per Second
- **MAC:** Media Access Control
- **Drive:** Yaskawa iQpump1000 Intelligent Pump Controller
- **BCD:** Binary Coded Decimal
- **Mbps:** Megabits per Second
- **r/min:** Revolutions per Minute
- **V/f:** V/f Control
- **OLV:** Open Loop Vector Control

## ◆ Trademarks

- BACnet is a trademark of the American Society of Heating, Refrigerating, and Air-Conditioning Engineers (ASHRAE).
- CANopen is a trademark of CAN in Automation (CiA).
- CC-Link is a trademark of CC-Link Partner Association (CLPA).
- CompoNet is a trademark of Open DeviceNet Vendor Association, Inc. (ODVA).
- DeviceNet is a trademark of Open DeviceNet Vendor Association, Inc. (ODVA).
- EtherCAT is a trademark of Beckhoff Automation GmbH, Germany.
- EtherNet/IP is a trademark of Open DeviceNet Vendor Association, Inc. (ODVA).
- LonWorks is a trademark of Echelon Corporation.
- MECHATROLINK-I/MECHATROLINK-II are trademarks of MECHATROLINK Members Association (MMA).
- Modbus is a trademark of Schneider Electric.
- PROFIBUS-DP is a trademark of PROFIBUS International (PI).
- PROFNET is a trademark of PROFIBUS International (PI).
- Other companies and product names mentioned in this manual are trademarks of those companies.

## i.2 General Safety

### ◆ Supplemental Safety Information

#### General Precautions

- The diagrams in this manual may be indicated without covers or safety shields to show details. Replace the covers or shields before operating the drive and run the drive according to the instructions described in this manual.
- Any illustrations, photographs, or examples used in this manual are provided as examples only and may not apply to all products to which this manual is applicable.
- The products and specifications described in this manual or the content and presentation of the manual may be changed without notice to improve the product and/or the manual.
- When ordering a new copy of the manual due to damage or loss, contact your Yaskawa representative or the nearest Yaskawa sales office and provide the manual number shown on the front cover.
- If nameplate becomes worn or damaged, order a replacement from your Yaskawa representative or the nearest Yaskawa sales office.

#### WARNING

Read and understand this manual before installing, operating or servicing this drive. The drive must be installed according to this manual and local codes.

The following conventions are used to indicate safety messages in this manual. Failure to heed these messages could result in serious or fatal injury or damage to the products or to related equipment and systems.

#### DANGER

Indicates a hazardous situation, which, if not avoided, will result in death or serious injury.

#### WARNING

Indicates a hazardous situation, which, if not avoided, could result in death or serious injury.

**WARNING!** may also be indicated by a bold key word embedded in the text followed by an italicized safety message.

#### CAUTION

Indicates a hazardous situation, which, if not avoided, could result in minor or moderate injury.

**CAUTION!** may also be indicated by a bold key word embedded in the text followed by an italicized safety message.

#### NOTICE

Indicates a property damage message.

**NOTICE:** may also be indicated by a bold key word embedded in the text followed by an italicized safety message.



## ◆ Safety Messages

### DANGER

#### **Heed the safety messages in this manual.**

Failure to comply will result in death or serious injury.

The operating company is responsible for any injuries or equipment damage resulting from failure to heed the warnings in this manual.

#### **Electrical Shock Hazard**

##### **Before servicing, disconnect all power to the equipment.**

The internal capacitor remains charged even after the power supply is turned off. The charge indicator LED will extinguish when the DC bus voltage is below 50 Vdc. To prevent electric shock, wait for at least the time specified on the warning label, once all indicators are OFF, measure for unsafe voltages to confirm the drive is safe prior to servicing.

Failure to comply will result in death or serious injury.

### WARNING

#### **Sudden Movement Hazard**

##### **System may start unexpectedly upon application of power, resulting in death or serious injury.**

Clear all personnel from the drive, motor and machine area before applying power. Secure covers, couplings, shaft keys and machine loads before applying power to the drive.

#### **Electrical Shock Hazard**

##### **Do not attempt to modify or alter the drive in any way not explained in this manual.**

Failure to comply could result in death or serious injury.

Yaskawa is not responsible for any modification of the product made by the user. This product must not be modified.

##### **Do not allow unqualified personnel to use equipment.**

Failure to comply could result in death or serious injury.

Installation, maintenance, inspection, and service must be performed only by authorized personnel familiar with installation, adjustment and maintenance of AC drives.

##### **Do not remove covers or touch circuit boards while the power is on.**

Failure to comply could result in death or serious injury.

##### **Make sure the protective earthing conductor complies with technical standards and local safety regulations.**

Because the leakage current exceeds 3.5 mA in models 4A0414 and larger, IEC/EN 61800-5-1 states that either the power supply must be automatically disconnected in case of discontinuity of the protective earthing conductor or a protective earthing conductor with a cross-section of at least 10 mm<sup>2</sup> (Cu) or 16 mm<sup>2</sup> (Al) must be used. Failure to comply may result in death or serious injury.

##### **Always use appropriate equipment for Ground Fault Circuit Interrupters (GFCIs).**

The drive can cause a residual current with a DC component in the protective earthing conductor. Where a residual current operated protective or monitoring device is used for protection in case of direct or indirect contact, always use a type B GFCI according to IEC/EN 60755.

#### **Fire Hazard**

##### **Do not use an improper voltage source.**

Failure to comply could result in death or serious injury by fire.

Verify that the rated voltage of the drive matches the voltage of the incoming power supply before applying power.

**Install adequate branch circuit protection according to applicable local codes and this Installation Manual. Failure to comply could result in fire and damage to the drive or injury to personnel.**

### WARNING

The device is suitable for use on a circuit capable of delivering not more than 100,000 RMS symmetrical amperes, 240 Vac maximum (200 V class) and 480 Vac maximum (400 V class), and 600 Vac maximum (600 V class) when protected by branch circuit protection devices specified in this document.

#### **Crush Hazard**

**Do not use this drive in lifting applications without installing external safety circuitry to prevent accidental dropping of the load.**

**The drive does not possess built-in load drop protection for lifting applications.**

Failure to comply could result in death or serious injury from falling loads.

Install electrical and/or mechanical safety circuit mechanisms independent of drive circuitry.

### CAUTION

#### **Crush Hazard**

**Do not carry the drive by the front cover.**

Failure to comply may result in minor or moderate injury from the main body of the drive falling.

### NOTICE

**Observe proper electrostatic discharge procedures (ESD) when handling the drive and circuit boards. Failure to comply may result in ESD damage to the drive circuitry.**

**Do not perform a withstand voltage test or megger test on any part of the drive.**

Failure to comply could result in damage to the sensitive devices within the drive.

**Do not operate damaged equipment.**

Failure to comply could result in further damage to the equipment. Do not connect or operate any equipment with visible damage or missing parts.

**If a fuse is blown or a Ground Fault Circuit Interrupter (GFCI) is tripped, check the wiring and the selection of the peripheral devices.**

Check for short circuits or ground faults on the secondary side of fuses and GFCIs and check the wiring and the selection of peripheral devices. Remove the cause of the problem and then turn the power supply off and on again. If the cause cannot be identified, do not turn on the power supply or attempt to operate the equipment.

**Do not restart the drive immediately operate the peripheral devices if a fuse is blown or a GFCI is tripped.**

Check the wiring and the selection of peripheral devices to identify the cause. Contact your supplier before restarting the drive or the peripheral devices if the cause cannot be identified.

**Do not expose the drive to halogen group disinfectants.**

Failure to comply may cause damage to the electrical components in the drive.

Do not pack the drive in wooden materials that have been fumigated or sterilized. Do not sterilize the entire package after the product is packed.

## ◆ General Application Precautions

### ■ Selection

#### Installing a Reactor

Use an AC reactor or DC link choke in the following situations:

- to suppress harmonic current.
- to smooth peak current that results from capacitor switching.
- when the power supply is above 600 kVA.

- when the drive is running from a power supply system with thyristor converters.

**Note:** A DC link choke is built in to drive models 2A0110 to 2A0415, 4A0058 to 4A1200, and 5A0041 to 5A0242.

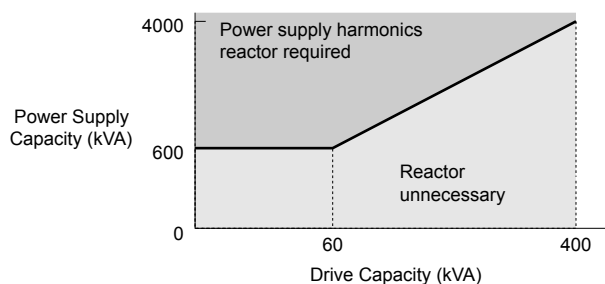

Figure i.1 Installing a Reactor

### Single-Phase Input Selection

The drive is capable of single phase input. [Refer to Main Circuit Connection Diagram on page 95](#) for connection diagrams and [Refer to Single-Phase Derating on page 329](#) for application instructions and drive current ratings.

### Drive Capacity

For specialized motors, make sure that the motor rated current is less than the rated output current for the drive.

When running more than one motor in parallel from a single drive, the capacity of the drive should be larger than [total motor rated current  $\times$  1.1].

## ■ Installation

### Enclosure Panels

Keep the drive in a clean environment by installing the drive in an enclosure panel or selecting an installation area free of airborne dust, lint, and oil mist. Be sure to leave the required space between drives to provide for cooling, and take proper measures so the ambient temperature remains within allowable limits and keep flammable materials away from the drive. Yaskawa offers protective designs for drives that must be used in areas subjected to oil mist and excessive vibration. Contact Yaskawa or your Yaskawa agent for details.

### Installation Direction

**NOTICE:** Install the drive upright as specified in the manual. Refer to the Mechanical Installation section for more information on installation. Failure to comply may damage the drive due to improper cooling.

## ■ Settings

### Upper Limits

**NOTICE:** The drive is capable of running the motor up to 400 Hz. Be sure to set the upper limit for the frequency of the drive to prevent the possible danger of accidentally operating equipment at higher than rated speed. The default setting for the maximum output frequency is 60 Hz.

### Lower Limits

**NOTICE:** Many pumps have a minimum safe operating speed. Be sure to properly set the minimum pump speed in to protect the pump from damage.

### DC Injection Braking

**NOTICE:** Excessive current during DC Injection Braking and excessive duration of DC Injection Braking can cause motor overheat.

### Acceleration/Deceleration Times

Acceleration and deceleration times are affected by the amount of torque generated by the motor, the load torque, and the inertia moment. Set a longer accel/decel time when Stall Prevention is enabled. The accel/decel times are lengthened for as long as the Stall Prevention function is in operation.

## ■ General Handling

### Wiring Check

**NOTICE:** Do not connect power supply lines to output terminals U/T1, V/T2, or W/T3. Failure to comply will destroy the drive. Be sure to perform a final check of all sequence wiring and other connections before turning on the power and also check for short circuits on the control terminals, which may damage the drive.

### Selecting a Circuit Breaker or Circuit Interrupter

Yaskawa recommends installing a Ground Fault Circuit Interrupter (GFCI) to the power supply side. The GFCI should be designed for use with AC drives (e.g., Type B according to IEC 60755).

## i.2 General Safety

---

Select a Molded Case Circuit Breaker (MCCB) or GFCI with a rated current 1.5 to 2 times higher than the drive rated input current to avoid nuisance trips caused by harmonics in the drive input current.

### Magnetic Contactor Installation

**NOTICE:** To get the full performance life out of the electrolytic capacitors and circuit relays, refrain from switching the drive power supply off and on more than once every 30 minutes. Frequent use can damage the drive. Use the drive to stop and start the motor.

### Inspection and Maintenance

**WARNING! Electrical Shock Hazard.** Capacitors in the drive do not immediately discharge after shutting off the power. Wait for at least the amount of time specified on the drive before touching any components after shutting off the power. Failure to comply may cause injury to personnel from electrical shock.

**WARNING! Burn Hazard.** Because the heatsink can get very hot during operation, take proper precautions to prevent burns. When replacing the cooling fan, shut off the power and wait at least 15 minutes to be sure that the heatsink has cooled down. Failure to comply may cause burn injury to personnel.

### Wiring

Yaskawa recommends using ring terminals on all drive models. Drive models 2A0069 to 2A0415, 4A0058 to 4A1200, and 5A0041 to 5A0242 require the use of use ring terminals for UL/cUL compliance. Use only the tools recommended by the terminal manufacturer for crimping.

### Transporting the Drive

**NOTICE:** Never steam clean the drive. During transport, keep the drive from coming into contact with salts, fluorine, bromine, phthalate ester, and other such harmful chemicals.

---

## ◆ Motor Application Precautions

### ■ Standard Induction Motors

#### Insulation Tolerance

**NOTICE:** Consider motor voltage tolerance levels and motor insulation in applications with an input voltage of over 440 V or particularly long wiring distances.

#### High-Speed Operation

**NOTICE:** Problems may occur with the motor bearings and dynamic balance of the machine when operating a motor beyond its rated speed. Contact the motor or machine manufacturer.

#### Torque Characteristics

Torque characteristics differ compared to operating the motor directly from line power. The user should have a full understanding of the load torque characteristics for the application.

#### Vibration and Shock

The drive allows selection of high carrier PWM control and low carrier PWM. Selecting high carrier PWM can help reduce motor oscillation (drive current derating may be required).

Take particular caution when adding a variable speed drive to an application running a motor from line power at a constant speed. If resonance occurs, use shock absorbing mounts to the motor base and enable the Jump frequency selection to prevent continuous operation in the resonant frequency range.

#### Audible Noise

The audible noise of the motor varies based on the carrier frequency setting. However, drive current derating may be required. When using a high carrier frequency, audible noise from the motor is comparable to the motor noise generated when running from line power.

#### Specialized Motors

##### Submersible Motor

The rated current of a submersible motor is greater than that of a standard motor, so select the drive accordingly. Use a motor cable large enough to avoid decreasing the maximum torque level from voltage drop caused by a long motor cable.

##### Explosion-Proof Motor

The motor and the drive must be tested together to be certified as explosion-proof. The drive is not designed for explosion-proof areas.

##### Geared Motor

Make sure that the gear and the lubricant are rated for the desired speed range to avoid gear damage when operating at low speeds or very high speeds. Consult with the manufacturer for applications that require operation outside the rated speed range of the motor or gear box.

**Single-Phase Motor**

Variable speed drives are not designed to operate with single phase motors. Using capacitors to start the motor causes a high-frequency current to flow to the capacitors and can damage the capacitors. A split-phase start or a repulsion start can burn out the starter coils because the internal centrifugal switch is not activated. The drive is for use with three-phase motors only.

**■ Notes on Power Transmission Machinery**

Installing an AC drive in machinery that was previously connected directly to the power supply will allow the machine to operate at variable speeds. Continuous operation outside of the rated speeds can wear out lubrication material in gear boxes and other power transmission parts. Make sure that lubrication is sufficient within the entire speed range to avoid machine damage. Note that operation above the rated speed can increase the noise generated by the machine.

### ◆ Drive Label Warning Example

Always heed the warning information listed in *Figure i.2*.

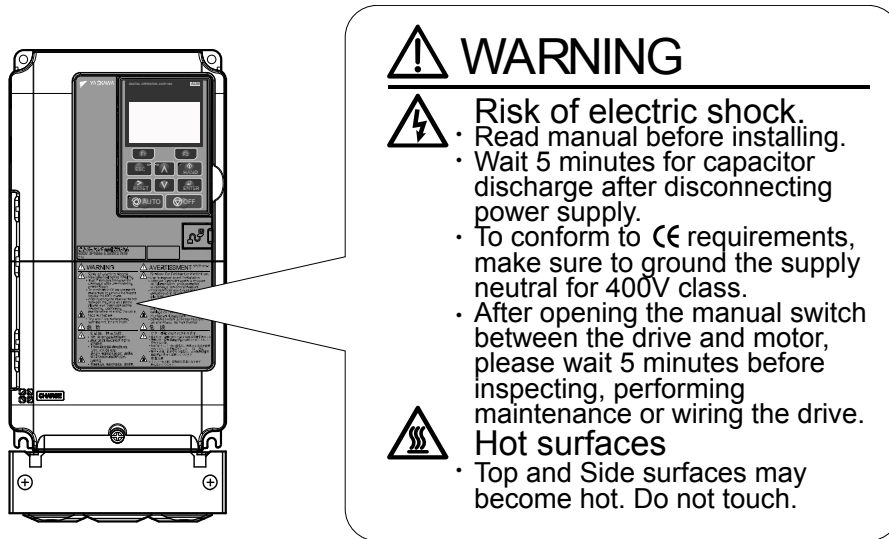

Figure i.2 Warning Information and Location

### ◆ Warranty Information

#### ■ Restrictions

The drive is not designed or manufactured for use in devices or systems that may directly affect or threaten human lives or health.

Customers who intend to use the product described in this manual for devices or systems relating to transportation, health care, space aviation, atomic power, electric power, or in underwater applications must first contact their Yaskawa representatives or the nearest Yaskawa sales office.

**WARNING! Injury to Personnel.** *This product has been manufactured under strict quality-control guidelines. However, if this product is to be installed in any location where failure of this product could involve or result in a life-and-death situation or loss of human life or in a facility where failure may cause a serious accident or physical injury, safety devices must be installed to minimize the likelihood of any accident.*

## Receiving

---

This chapter explains how to inspect the drive upon receipt, and gives an overview of the different enclosure types and components.

<b>1.1</b>	<b>MODEL NUMBER AND NAMEPLATE CHECK.....</b>	<b>32</b>
------------	--	-----------

## 1.1 Model Number and Nameplate Check

Please perform the following tasks after receiving the drive:

- Inspect the drive for damage.  
If the drive appears damaged upon receipt, contact the shipper immediately.
- Verify receipt of the correct model by checking the information on the nameplate.
- If you have received the wrong model or the drive does not function properly, contact your supplier.

### ◆ Nameplate

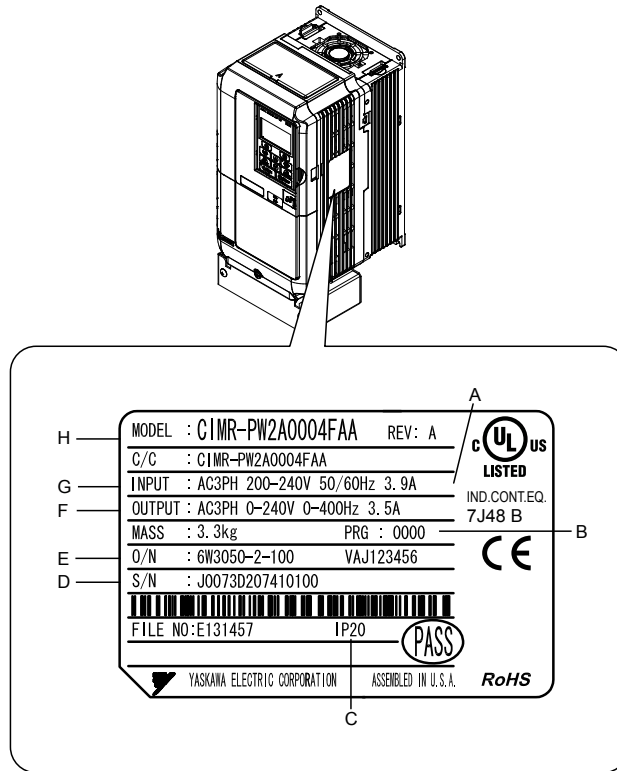

**A** – Normal Duty Amps  
**B** – Software version  
**C** – Enclosure type  
**D** – Serial number

**E** – Lot number  
**F** – Output specifications  
**G** – Input specifications  
**H** – AC drive model

Figure 1.1 Nameplate Information Example



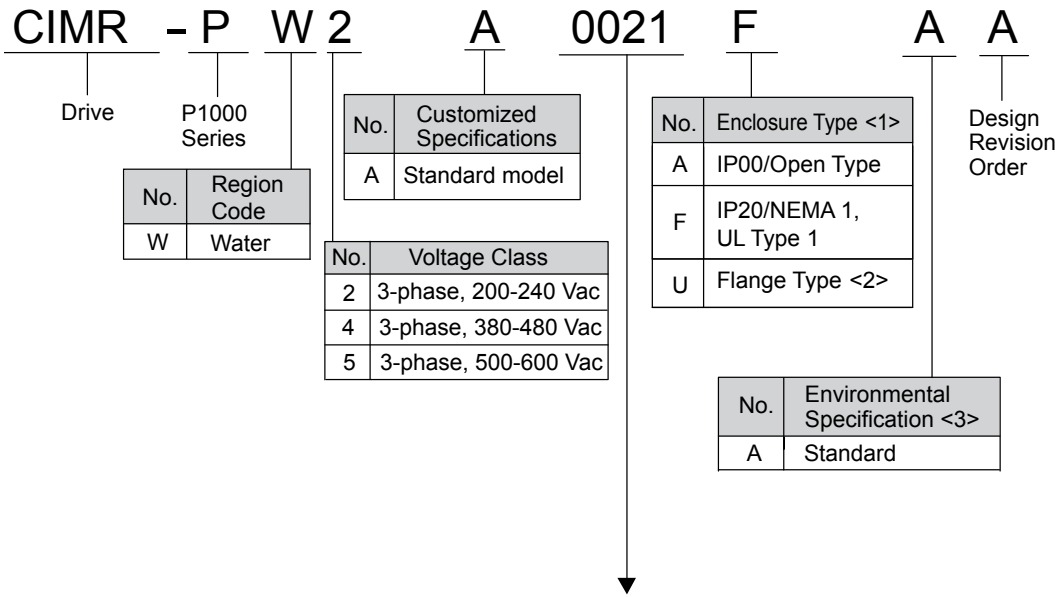

Refer to the tables below

<1> Refer to *Mechanical Installation on page 36* for differences regarding enclosure protection types and component descriptions.

<2> Provides method of mounting drive with backside (heatsink) external to enclosure, with NEMA 12 integrity.

<3> Please contact Yaskawa for details regarding Environmental Specifications.

**■ Three-Phase 200 V Class**

Drive Model	Max. Motor Capacity kW (HP)	Rated Output Current A
2A0004	0.75 (0.75)	3.5
2A0006	1.1 (1)	6.0
2A0008	1.5 (2)	8.0
2A0010	2.2 (3)	9.6
2A0012	3.0 (3)	12
2A0018	3.7 (5)	17.5
2A0021	5.5 (7.5)	21
2A0030	7.5 (10)	30
2A0040	11 (15)	40
2A0056	15 (20)	56
2A0069	18.5 (25)	69
2A0081	22 (30)	81
2A0110	30 (40)	110
2A0138	37 (50)	138
2A0169	45 (60)	169
2A0211	55 (75)	211
2A0250	75 (100)	250
2A0312	90 (125)	312
2A0360	110 (150)	360
2A0415	110 (175)	415

## 1.1 Model Number and Nameplate Check

### ■ Three-Phase 400 V Class

Drive Model	Max. Motor Capacity kW (HP)	Rated Output Current A
4A0002	0.75 (0.75)	2.1
4A0004	1.5 (2)	4.1
4A0005	2.2 (3)	5.4
4A0007	3.0 (3)	6.9
4A0009	3.7 (5)	8.8
4A0011	5.5 (7.5)	11.1
4A0018	7.5 (10)	17.5
4A0023	11 (15)	23
4A0031	15 (20)	31
4A0038	18.5 (25)	38
4A0044	22 (30)	44
4A0058	30 (40)	58
4A0072	37 (50)	72
4A0088	45 (60)	88
4A0103	55 (75)	103
4A0139	75 (100)	139
4A0165	90 (125)	165
4A0208	110 (150)	208
4A0250	132 (200)	250
4A0296	160 (250)	296
4A0362	185 (300)	362
4A0414	220 (350)	414
4A0515	250 (400-450)	515
4A0675	355 (500-550)	675
4A0930	500 (750)	930
4A1200	630 (1000)	1200

### ■ Three-Phase 600 V Class

Drive Model	Max. Motor Capacity kW (HP)	Rated Output Current A
5A0003	1.5 (2)	2.7
5A0004	2.2 (3)	3.9
5A0006	3.7 (5)	6.1
5A0009	5.5 (7.5)	9
5A0011	7.5 (10)	11
5A0017	11 (15)	17
5A0022	15 (20)	22
5A0027	18.5 (25)	27
5A0032	22 (30)	32
5A0041	30 (40)	41
5A0052	37 (50)	52
5A0062	45 (60)	62
5A0077	55 (75)	77
5A0099	75 (100)	99
5A0125	90 (125)	125
5A0145	110 (150)	145
5A0192	160 (200)	192
5A0242	185 (250)	242

Note: Refer to [Single-Phase Derating on page 329](#) for Single-Phase ratings.

## Mechanical Installation

---

This chapter explains how to properly mount and install the drive.

<b>2.1</b>	<b>MECHANICAL INSTALLATION.....</b>	<b>36</b>
<b>2.2</b>	<b>FLANGE TYPE ENCLOSURE (NEMA 12 BACKSIDE) DIMENSIONS &amp; HEAT LOSS.....</b>	<b>53</b>

## 2.1 Mechanical Installation

# 2.1 Mechanical Installation

This section outlines specifications, procedures, and the environment for proper mechanical installation of the drive.

### ◆ Installation Environment

Install the drive in an environment matching the specifications in [Table 2.1](#) to help prolong the optimum performance life of the drive.

**Table 2.1 Installation Environment**

Environment	Conditions
Installation Area	Indoors
Ambient Temperature	-10 °C to +40 °C (IP20/NEMA 1, UL Type 1 enclosure) -10 °C to +50 °C (IP00/Open Type enclosure) Drive reliability improves in environments without wide temperature fluctuations. When using the drive in an enclosure panel, install a cooling fan or air conditioner in the area to ensure that the air temperature inside the enclosure does not exceed the specified levels. Do not allow ice to develop on the drive.
Humidity	95% RH or less and free of condensation
Storage Temperature	-20 to +60 °C
Surrounding Area	Install the drive in an area free from: <ul style="list-style-type: none"><li>• oil mist and dust</li><li>• metal shavings, oil, water, or other foreign materials</li><li>• radioactive materials</li><li>• combustible materials (e.g., wood)</li><li>• harmful gases and liquids</li><li>• excessive vibration</li><li>• chlorides</li><li>• direct sunlight.</li></ul>
Altitude	1000 m or lower, up to 3000 m with derating
Vibration	10 to 20 Hz at 9.8 m/s <sup>2</sup> (32.15 ft/s <sup>2</sup> ) <1> 20 to 55 Hz at 5.9 m/s <sup>2</sup> (19.36 ft/s <sup>2</sup> ) (Models 2A0004 to 2A0211, 4A0002 to 4A0165, and 5A0003 to 5A0099) or 2.0 m/s <sup>2</sup> (6.56 ft/s <sup>2</sup> ) (Models 2A0250 to 2A0415, 4A0208 to 4A1200, and 5A0125 to 5A0242)
Orientation	Install the drive vertically to maintain maximum cooling effects.

<1> Models 4A0930 and 4A1200 are rated at 5.9 m/s<sup>2</sup> (19.36 ft/s<sup>2</sup>)

**NOTICE:** Avoid placing drive peripheral devices, transformers, or other electronics near the drive as the noise created can lead to erroneous operation. If such devices must be used in close proximity to the drive, take proper steps to shield the drive from noise.

**NOTICE:** Prevent foreign matter such as metal shavings and wire clippings from falling into the drive during installation. Failure to comply could result in damage to the drive. Place a temporary cover over the top of the drive during installation. Remove the temporary cover before drive start-up, as the cover will reduce ventilation and cause the drive to overheat.

### ◆ Installation Orientation and Spacing

**NOTICE:** Install the drive upright as illustrated in [Figure 2.1](#). Failure to comply may damage the drive due to improper cooling.

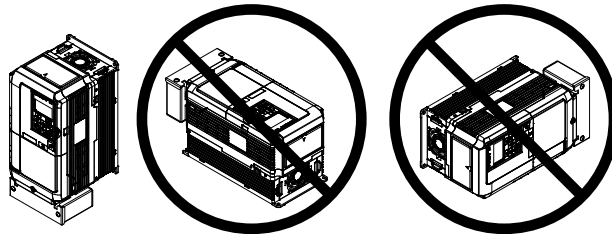

**Figure 2.1 Correct Installation Orientation**

**NOTICE:** Install the drive upright as specified in the manual. Failure to comply may damage the drive due to improper cooling.

### Single Drive Installation

Figure 2.2 shows the installation distance required to maintain sufficient space for airflow and wiring. Install the heatsink against a closed surface to avoid diverting cooling air around the heatsink.

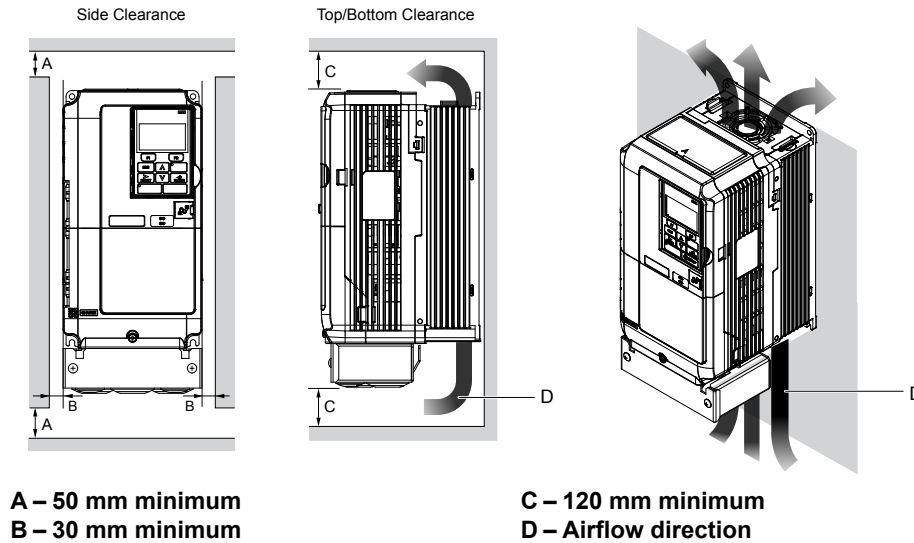

Figure 2.2 Correct Installation Spacing

**Note:** IP20/NEMA 1, UL Type 1 enclosure and IP00/Open Type enclosure models require the same amount of space above and below the drive for installation.

### Multiple Drive Installation (Side-by-Side Installation)

Models 2A0004 to 2A0081, 4A0002 to 4A0044, and 5A0003 to 5A0032 can take advantage of Side-by-Side installation.

When installing multiple drives into the same enclosure panel, mount the drives according to Figure 2.2 and set L8-35, Installation Method Selection, to 1 (Side-by-Side Mounting).

When mounting drives with the minimum clearance of 2 mm according to Figure 2.3, set parameter L8-35 to 1 while considering derating.

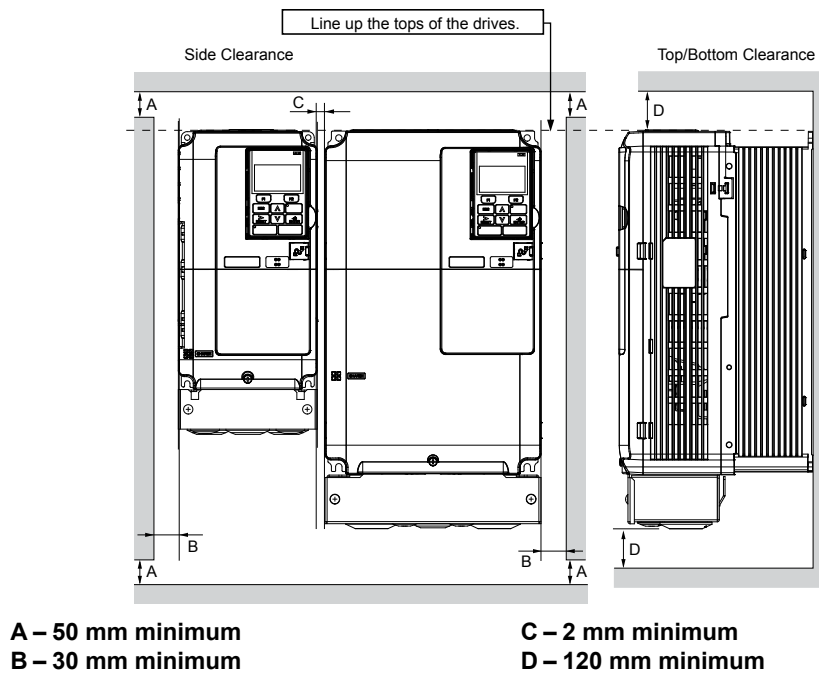

Figure 2.3 Space Between Drives (Side-by-Side Mounting)

**Note:** Align the tops of the drives when installing drives of different heights in the same enclosure panel. Leave space between the tops and bottoms of stacked drives for easier cooling fan replacement.

## 2.1 Mechanical Installation

Remove the top protective covers of all drives as shown in [Figure 2.4](#) when mounting IP20/NEMA 1, UL Type 1 enclosure drives side-by-side. [Refer to Top Protective Cover on page 106](#) to remove and reattach the top protective cover.

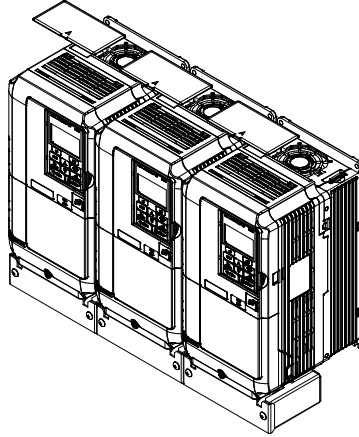

Figure 2.4 IP20/NEMA 1, UL Type 1 Side-by-Side Mounting in Enclosure

### ◆ Instructions on Installation Using the Eye Bolts

Eye bolts are used to install the drive or to temporarily lift the drive when replacing it. Using the eye bolts, the drive can be installed in an enclosure panel or on a wall. Do not leave the drive suspended by the wires in a horizontal or vertical position for long periods of time. Do not transport the drive over long distances. Read the following precautions and instructions before installing the drive.

**WARNING! Crush Hazard.** Observe the following instructions and precautions. Failure to comply could result in serious injury or death from falling equipment.

Only use vertical suspension to temporarily lift the drive during installation to an enclosure panel. Do not use vertical suspension to transport the drive.

Use screws to securely affix the drive front cover, terminal blocks, and other drive components prior to vertical suspension.

Do not subject the drive to vibration or impact greater than  $1.96 \text{ m/s}^2$  (0.2 G) while it is suspended by the wires.

Do not leave the drive unattended while it is suspended by the wires.

Do not attempt to flip the drive over while it is suspended by the wires.

### ■ Horizontal Suspension of Drive Models 2A0360, 2A0415, and 4A0250 to 4A0675

To make a wire hanger or frame for use when lifting the drive with a crane, lay the drive in a horizontal position and pass a wire through the holes of the four eye bolts.

**NOTICE: Damage to Equipment.** When lifting the drive, confirm that the spring washer is fully closed. Failure to comply may deform or damage the drive when lifted.

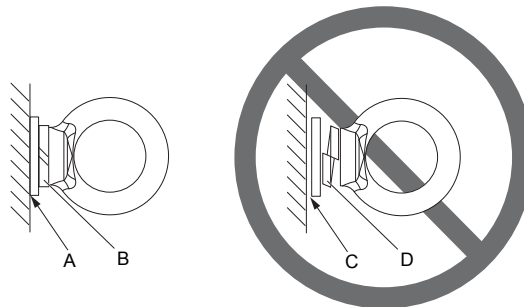

A – No space between drive and washer  
B – Spring washer fully closed

C – Space between drive and washer  
D – Spring washer open

Figure 2.5 Spring Washer

## ■ Vertical Suspension of Drive Models 2A0360, 2A0415, and 4A0250 to 4A1200

### Models 2A0360, 2A0415, and 4A0250 to 4A0675

When vertical suspension of the drive is required in an enclosure panel, change the orientation of the eye bolts for these models by turning the eye bolts counterclockwise 90 degrees.

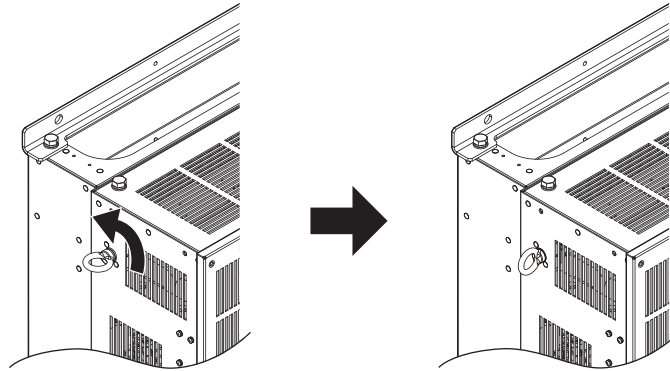

Figure 2.6 Adjusting Angle of Eye Bolts

### Models 4A0930 and 4A1200

When suspending models 4A0930 or 4A1200 with wires, follow the procedure described below.

**WARNING! Crush Hazard.** Use an adequate length of wire to ensure a 50° or wider suspension angle as illustrated in Figure 2.8. The maximum allowable load of the eye bolts cannot be guaranteed when the drive is suspended with the wires at angles less than 50°. Failure to comply may result in serious injury or death from falling equipment.

1. Remove the four eye bolts from the drive side panels and fix them securely on the top panel.

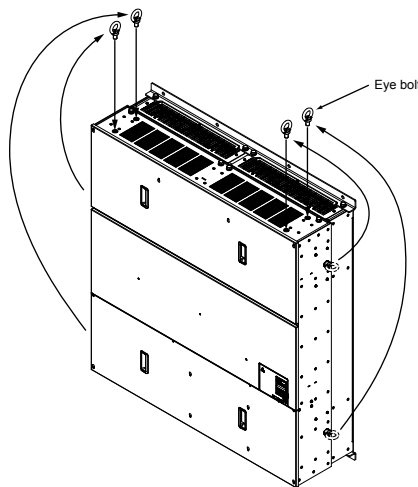
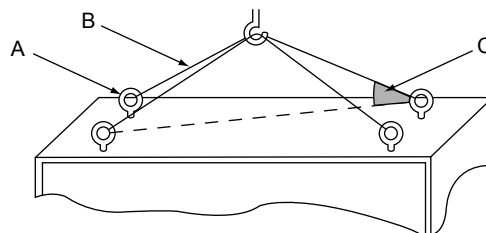

Figure 2.7 Eye Bolt Repositioning

2. Pass wire through the holes of all four eye bolts.



A – Eye bolt  
B – Wires

C – Suspending angle: 50° or greater

Figure 2.8 Suspension Wire Angle Example

## 2.1 Mechanical Installation

3. Gradually take up the slack in the wires and hoist the drive after the wires are stretched tight.
4. Lower the drive when ready to install in the enclosure panel. Stop lowering the drive when it is near the floor then begin lowering the drive again very slowly until the drive is placed correctly.

### ◆ HOA Keypad Remote Usage

#### ■ Remote Operation

The HOA keypad mounted on the drive can be removed and connected to the drive using an extension cable up to 3 m (9.8 ft.) long to facilitate operation when the drive is installed in a location where it can not be easily accessed.

The HOA keypad can also be permanently mounted remote locations such as panel doors using an extension cable and an installation support set (depending on the installation type).

**Note:** Refer to *Peripheral Devices & Options on page 309* for information on extension cables and installation support sets.

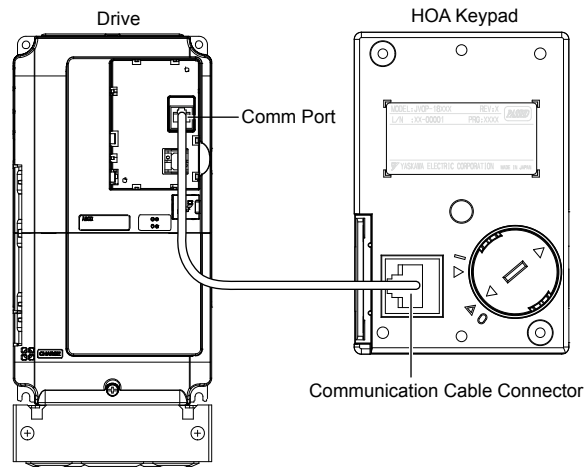

Figure 2.9 Communication Cable Connection

#### ■ HOA Keypad Remote Installation

##### HOA Keypad Dimensions

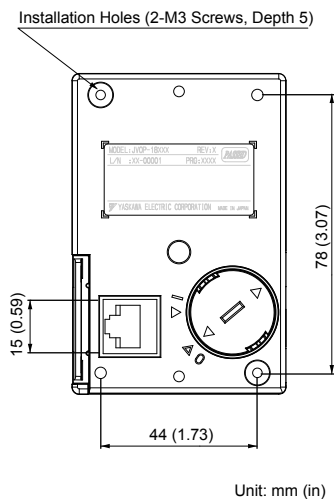

Figure 2.10 HOA Keypad Dimensions

##### Installation Types and Required Materials

The HOA keypad mounts to an enclosure two different ways:

- **External/face-mount** installs the HOA keypad outside the enclosure panel
- **Internal/flush-mount** installs the HOA keypad inside the enclosure panel



Table 2.2 HOA Keypad Installation Methods and Required Tools

Installation Method	Description	Installation Support Sets	Model	Required Tools
External/ Face-Mount	Simplified installation with the HOA keypad is mounted on the outside of the panel with two screws.	-	-	Phillips screwdriver (#1)
Internal/ Flush-Mount	Encloses the HOA keypad in the panel. The front of the HOA keypad is flush with the outside of the panel.	Installation Support Set A (for mounting with screws through holes in the panel)	EZZ020642A	Phillips screwdriver (#1, #2)
		Installation Support Set B (for use with threaded studs that are fixed to the panel)	EZZ020642B	Phillips screwdriver (#1) Wrench (7 mm)

**NOTICE:** Prevent foreign matter such as metal shavings or wire clippings from falling into the drive during installation and project construction. Failure to comply could result in damage to the drive. Place a temporary cover over the top of the drive during installation. Remove the temporary cover before drive start-up, as the cover will reduce ventilation and cause the drive to overheat.

**External/Face-Mount**

1. Cut an opening in the enclosure panel for the HOA keypad as shown in [Figure 2.11](#).
2. Position the HOA keypad so the display faces outwards, and mount it to the enclosure panel as shown in [Figure 2.12](#).

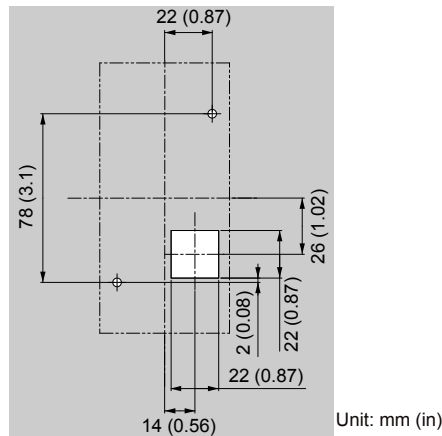

Figure 2.11 Panel Cut-Out Dimensions (External/Face-Mount Installation)

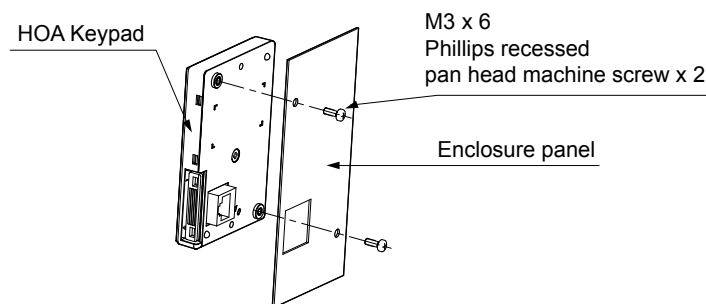

Figure 2.12 External/Face-Mount Installation

**Internal/Flush-Mount**

An internal/flush-mount requires an installation support set that must be purchased separately. Contact Yaskawa to order an installation support set and mounting hardware. [Figure 2.13](#) illustrates how to attach the Installation Support Set A.

1. Cut an opening in the enclosure panel for the HOA keypad as shown in [Figure 2.14](#).
2. Mount the HOA keypad to the installation support.
3. Mount the installation support set and HOA keypad to the enclosure panel.

## 2.1 Mechanical Installation

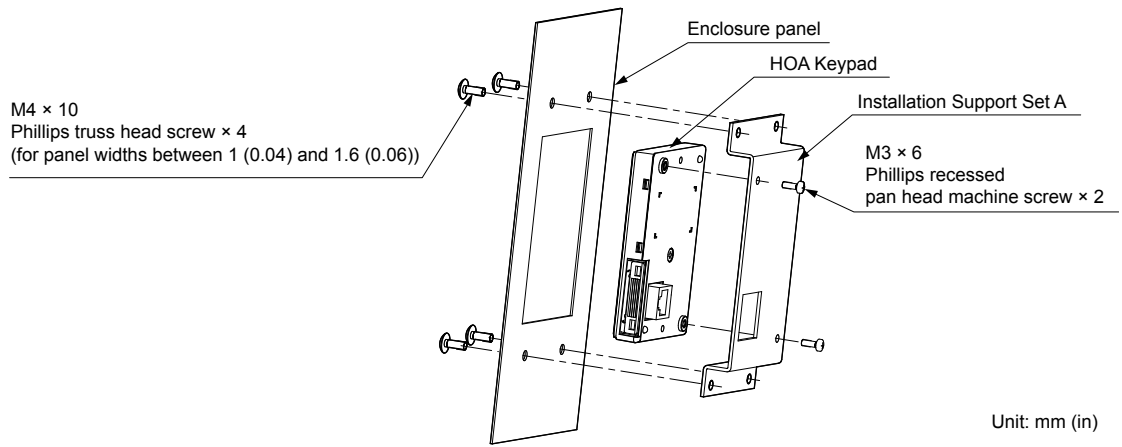

**Figure 2.13 Internal/Flush Mount Installation**

**Note:** Use a gasket between the enclosure panel and the HOA keypad in environments with a significant amount of dust or other airborne debris.

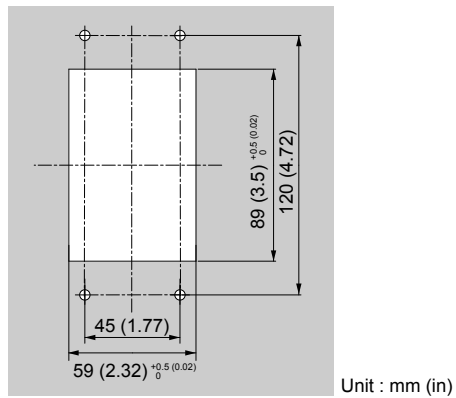

**Figure 2.14 Panel Cut-Out Dimensions (Internal/Flush-Mount Installation)**

◆ Exterior and Mounting Dimensions

Table 2.3 Drive Models and Types

Protective Design	Drive Model			Page
	Three-Phase 200 V Class	Three-Phase 400 V Class	Three-Phase 600 V Class	
IP20/NEMA 1, UL Type 1 Enclosure	2A0004F 2A0006F 2A0008F 2A0010F 2A0012F 2A0018F 2A0021F 2A0030F 2A0040F 2A0056F 2A0069F 2A0081F 2A0110F 2A0138F 2A0169F 2A0211F	4A0002F 4A0004F 4A0005F 4A0007F 4A0009F 4A0011F 4A0018F 4A0023F 4A0031F 4A0038F 4A0044F 4A0058F 4A0072F 4A0088F 4A0103F 4A0139F 4A0165F	5A0003F 5A0004F 5A0006F 5A0009F 5A0011F 5A0017F 5A0022F 5A0027F 5A0032F 5A0041F 5A0052F 5A0062F 5A0077F 5A0099F	44
IP00/Open Type Enclosure	2A0250A <1> 2A0312A <1> 2A0360A <1> 2A0415A <2>	4A0208A <1> 4A0250A <1> 4A0296A <1> 4A0362A <1> 4A0414A <2> 4A0515A <2> 4A0675A <2> 4A0930A <2> 4A1200A <2>	5A0125A <1> 5A0145A <1> 5A0192A <1> 5A0242A <1>	50
Flange Type Enclosure (NEMA 12 Backside)	2A0004U 2A0006U 2A0008U 2A0010U 2A0012U 2A0018U 2A0021U 2A0030U 2A0040U 2A0056U 2A0069U 2A0081U 2A0110U 2A0138U 2A0169U 2A0211U 2A0250U 2A0312U 2A0360U 2A0415U	4A0002U 4A0004U 4A0005U 4A0007U 4A0009U 4A0011U 4A0018U 4A0023U 4A0031U 4A0038U 4A0044U 4A0058U 4A0072U 4A0088U 4A0103U 4A0139U 4A0165U 4A0208U 4A0250U 4A0296U 4A0362U 4A0414U 4A0515U 4A0675U 4A0930U 4A1200U	5A0003U 5A0004U 5A0006U 5A0009U 5A0011U 5A0017U 5A0022U 5A0032U 5A0041U 5A0052U 5A0062U 5A0077U 5A0099U 5A0125U 5A0145U 5A0192U 5A0242U	53

<1> Customers may convert these models to IP20/NEMA 1, UL Type 1 enclosures using an IP20/NEMA 1, UL Type 1 Kit. Refer to IP20/NEMA 1, UL Type 1 Kit Selection on page 52 to select the appropriate kit.  
 <2> Contact a Yaskawa representative for IP20/NEMA 1, UL Type 1 Kit availability for these models.

## 2.1 Mechanical Installation

### ■ IP20/NEMA 1, UL Type 1 Enclosure Drives

**Note:** Removing the top protective cover or bottom conduit bracket from an IP20/NEMA 1, UL Type 1 enclosure drive voids NEMA 1, UL Type 1 protection while maintaining IP20 conformity.

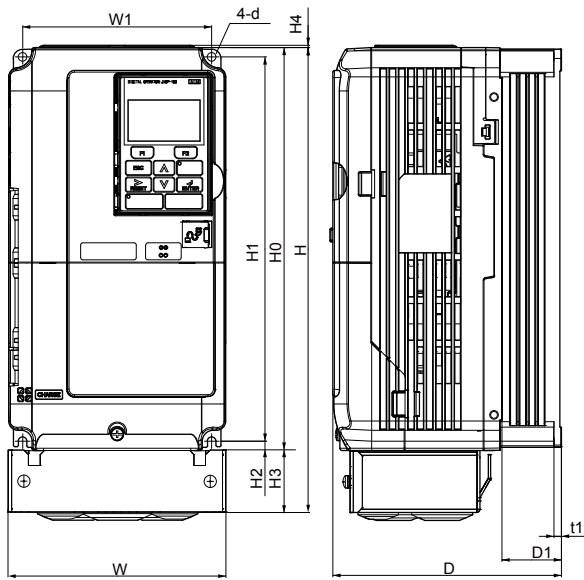

Figure 1

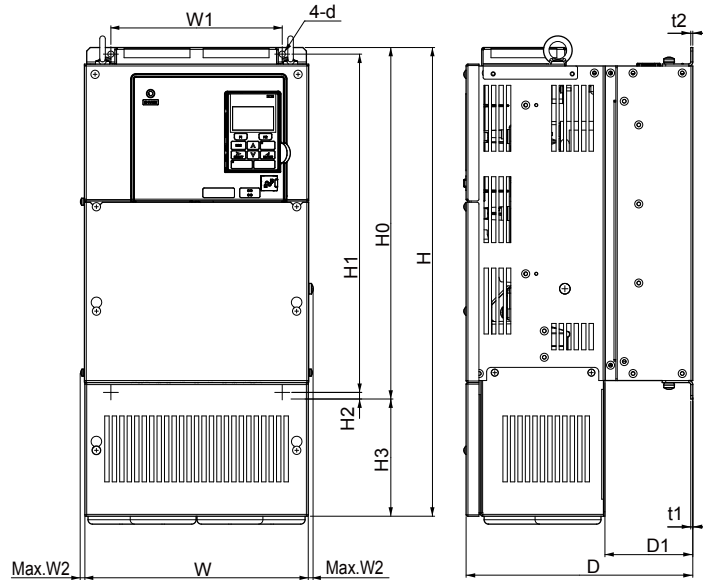

Figure 2

**Table 2.4 Dimensions for IP20/NEMA 1, UL Type 1 Enclosure: 200 V Class**

Drive Model	Figure	Dimensions mm (in)														Wt. kg (lb)	
		W	H	D	W1	W2	H0	H1	H2	H3	H4	D1	t1	t2	d		
2A0004F	1 < >	140 (5.51)	300 (11.81)	147 (5.79)	122 (4.80)	–	260 (10.24)	248 (9.76)	6 (0.24)	40 (1.57)	1.5 (0.06)	38 (1.50)	5 (0.20)	–	M5	3.3 (7.3)	
2A0006F		140 (5.51)	300 (11.81)	147 (5.79)	122 (4.80)	–	260 (10.24)	248 (9.76)	6 (0.24)	40 (1.57)	1.5 (0.06)	38 (1.50)	5 (0.20)	–	M5	3.3 (7.3)	
2A0008F		140 (5.51)	300 (11.81)	147 (5.79)	122 (4.80)	–	260 (10.24)	248 (9.76)	6 (0.24)	40 (1.57)	1.5 (0.06)	38 (1.50)	5 (0.20)	–	M5	3.4 (7.5)	
2A0010F		140 (5.51)	300 (11.81)	147 (5.79)	122 (4.80)	–	260 (10.24)	248 (9.76)	6 (0.24)	40 (1.57)	1.5 (0.06)	38 (1.50)	5 (0.20)	–	M5	3.4 (7.5)	
2A0012F		140 (5.51)	300 (11.81)	147 (5.79)	122 (4.80)	–	260 (10.24)	248 (9.76)	6 (0.24)	40 (1.57)	1.5 (0.06)	38 (1.50)	5 (0.20)	–	M5	3.4 (7.5)	
2A0018F		140 (5.51)	300 (11.81)	164 (6.46)	122 (4.80)	–	260 (10.24)	248 (9.76)	6 (0.24)	40 (1.57)	1.5 (0.06)	55 (2.17)	5 (0.20)	–	M5	3.8 (8.2)	
2A0021F		140 (5.51)	300 (11.81)	164 (6.46)	122 (4.80)	–	260 (10.24)	248 (9.76)	6 (0.24)	40 (1.57)	1.5 (0.06)	55 (2.17)	5 (0.20)	–	M5	3.8 (8.2)	
2A0030F		140 (5.51)	300 (11.81)	167 (6.57)	122 (4.80)	–	260 (10.24)	248 (9.76)	6 (0.24)	40 (1.57)	1.5 (0.06)	55 (2.17)	5 (0.20)	–	M5	4.2 (9.3)	
2A0040F		140 (5.51)	300 (11.81)	167 (6.57)	122 (4.80)	–	260 (10.24)	248 (9.76)	6 (0.24)	40 (1.57)	1.5 (0.06)	55 (2.17)	5 (0.20)	–	M5	4.2 (9.3)	
2A0056F		180 (7.09)	340 (13.39)	187 (7.36)	160 (6.30)	–	300 (11.81)	284 (11.18)	7.9 (0.31)	40 (1.57)	1.5 (0.06)	75 (2.95)	5 (0.20)	–	M5	5.9 (13.0)	
2A0069F		220 (8.66)	400 (15.75)	197 (7.76)	192 (7.56)	–	350 (13.78)	335 (13.19)	7.9 (0.31)	50 (1.97)	1.5 (0.06)	78 (3.07)	5 (0.20)	–	M6	9 (20.1)	
2A0081F		220 (8.66)	400 (15.75)	197 (7.76)	192 (7.56)	–	350 (13.78)	335 (13.19)	7.9 (0.31)	50 (1.97)	1.5 (0.06)	78 (3.07)	5 (0.20)	–	M6	10 (22.0)	
2A0110F		2 < >	254 (10.00)	534 (21.02)	258 (10.16)	195 (7.68)	7.9 (0.31)	400 (15.75)	385 (15.16)	7.7 (0.30)	134 (5.28)	1.5 (0.06)	100 (3.94)	2.2 (0.09)	2.286 (0.09)	M6	23 (50.7)
2A0138F			279 (10.98)	614 (24.17)	258 (10.16)	220 (8.66)	7.9 (0.31)	450 (17.72)	435 (17.13)	7.7 (0.30)	164 (6.46)	–	100 (3.94)	2.2 (0.09)	2.286 (0.09)	M6	28 (61.7)
2A0169F	329 (12.95)		730 (28.74)	283 (11.14)	260 (10.24)	7.9 (0.31)	550 (21.65)	535 (21.06)	7.7 (0.30)	180 (7.09)	–	110 (4.33)	2.2 (0.09)	2.286 (0.09)	M6	41 (90.4)	
2A0211F	329 (12.95)		730 (28.74)	283 (11.14)	260 (10.24)	7.9 (0.31)	550 (21.65)	535 (21.06)	7.7 (0.30)	180 (7.09)	–	110 (4.33)	2.2 (0.09)	2.286 (0.09)	M6	42 (92.6)	

Drive Model	Figure	Dimensions mm (in)														Wt. kg (lb)
		W	H	D	W1	W2	H0	H1	H2	H3	H4	D1	t1	t2	d	
Dimensions below are the dimensions of IP00/Open Type models after customer installation of the appropriate IP20/NEMA 1, UL Type 1 Kit.																
2A0250A	2	456 (17.95)	960 (37.80)	330 (12.99)	325 (12.80)	7.9 (0.31)	28 (27.76)	680 (26.77)	12 (0.49)	255 (10.04)	-	130 (5.12)	3.3 (0.13)	3.3 (0.13)	M10	83 (183.0)
2A0312A		456 (17.95)	960 (37.80)	330 (12.99)	325 (12.80)	7.9 (0.31)	28 (27.76)	680 (26.77)	12 (0.49)	255 (10.04)	-	130 (5.12)	3.3 (0.13)	3.30 (0.13)	M10	88 (194.0)
2A0360A		194 (19.84)	1168 (45.98)	35 (13.78)	370 (14.57)	7.9 (0.31)	800 (31.50)	773 (30.43)	13 (0.51)	368 (14.49)	-	130 (5.12)	4.6 (0.18)	4.6 (0.18)	M12	108 (238.1)

<1> Removing the top protective cover from an IP20/NEMA 1, UL Type 1 enclosure drive voids NEMA 1, UL Type 1 protection while retaining IP20 conformity.

Table 2.5 Dimensions for IP20/NEMA 1, UL Type 1 Enclosure: 400 V Class

Drive Model	Figure	Dimensions mm (in)														Wt. kg (lb)
		W	H	D	W1	W2	H0	H1	H2	H3	H4	D1	t1	t2	d	
4A0002F	1 </>	140 (5.51)	300 (11.81)	147 (5.79)	122 (4.80)	-	260 (10.24)	248 (9.76)	6 (0.24)	40 (1.57)	1.5 (0.06)	38 (1.50)	5 (0.20)	-	M5	3.4 (7.5)
4A0004F		140 (5.51)	300 (11.81)	147 (5.79)	122 (4.80)	-	260 (10.24)	248 (9.76)	6 (0.24)	40 (1.57)	1.5 (0.06)	38 (1.50)	5 (0.20)	-	M5	3.4 (7.5)
4A0005F		140 (5.51)	300 (11.81)	147 (5.79)	122 (4.80)	-	260 (10.24)	248 (9.76)	6 (0.24)	40 (1.57)	1.5 (0.06)	38 (1.50)	5 (0.20)	-	M5	3.4 (7.5)
4A0007F		140 (5.51)	300 (11.81)	164 (6.46)	122 (4.80)	-	260 (10.24)	248 (9.76)	6 (0.24)	40 (1.57)	1.5 (0.06)	55 (2.17)	5 (0.20)	-	M5	3.6 (7.9)
4A0009F		140 (5.51)	300 (11.81)	164 (6.46)	122 (4.80)	-	260 (10.24)	248 (9.76)	6 (0.24)	40 (1.57)	1.5 (0.06)	55 (2.17)	5 (0.20)	-	M5	3.8 (8.2)
4A0011F		140 (5.51)	300 (11.81)	164 (6.46)	122 (4.80)	-	260 (10.24)	248 (9.76)	6 (0.24)	40 (1.57)	1.5 (0.06)	55 (2.17)	5 (0.20)	-	M5	3.8 (8.2)
4A0018F		140 (5.51)	300 (11.81)	167 (6.57)	122 (4.80)	-	260 (10.24)	248 (9.76)	6 (0.24)	40 (1.57)	1.5 (0.06)	55 (2.17)	5 (0.20)	-	M5	4.0 (9.0)
4A0023F		140 (5.51)	300 (11.81)	167 (6.57)	122 (4.80)	-	260 (10.24)	248 (9.76)	6 (0.24)	40 (1.57)	1.5 (0.06)	55 (2.17)	5 (0.20)	-	M5	4.0 (9.0)
4A0031F		180 (7.09)	340 (13.39)	167 (6.57)	160 (6.30)	-	300 (11.81)	284 (11.18)	7.9 (0.31)	40 (1.57)	1.5 (0.06)	55 (2.17)	5 (0.20)	-	M5	5.8 (12.6)
4A0038F		180 (7.09)	340 (13.39)	187 (7.36)	160 (6.30)	-	300 (11.81)	284 (11.18)	7.9 (0.31)	40 (1.57)	1.5 (0.06)	75 (2.95)	5 (0.20)	-	M5	6.0 (13.2)
4A0044F		220 (8.66)	400 (15.75)	197 (7.76)	195 (7.68)	-	35 (13.78)	335 (13.19)	7.9 (0.31)	50 (1.97)	1.5 (0.06)	78 (3.07)	5 (0.20)	-	M6	8.8 (19.2)
4A0058F		254 (10.00)	465 (18.31)	258 (10.16)	195 (7.68)	7.9 (0.31)	400 (15.75)	385 (15.16)	7.7 (0.30)	65 (2.56)	-	100 (3.94)	2.2 (0.09)	2.2 (0.09)	M6	23 (50.7)
4A0072F		279 (10.98)	515 (20.28)	258 (10.16)	220 (8.66)	7.9 (0.31)	450 (17.72)	435 (17.13)	7.7 (0.30)	65 (2.56)	-	100 (3.94)	2.2 (0.09)	2.2 (0.09)	M6	27 (59.5)
4A0088F	329 (12.95)	630 (24.80)	258 (10.16)	260 (10.24)	7.9 (0.31)	509 (20.08)	495 (19.49)	7.7 (0.30)	120 (4.72)	-	105 (4.13)	2.2 (0.09)	3.3 (0.13)	M6	39 (86.0)	
4A0103F	329 (12.95)	630 (24.80)	258 (10.16)	260 (10.24)	7.9 (0.31)	509 (20.08)	495 (19.49)	7.7 (0.30)	120 (4.72)	-	105 (4.13)	2.2 (0.09)	3.3 (0.13)	M6	39 (86.0)	
4A0139F	329 (12.95)	730 (28.74)	283 (11.14)	260 (10.24)	7.9 (0.31)	550 (21.65)	535 (21.06)	7.7 (0.30)	180 (7.09)	-	110 (4.33)	2.2 (0.09)	2.2 (0.09)	M6	45 (99.2)	
4A0165F	329 (12.95)	730 (28.74)	283 (11.14)	260 (10.24)	7.9 (0.31)	550 (21.65)	535 (21.06)	7.7 (0.30)	180 (7.09)	-	110 (4.33)	2.2 (0.09)	2.2 (0.09)	M6	46 (101.4)	
Dimensions below are the dimensions of IP00/Open Type models after customer installation of the appropriate IP20/NEMA 1, UL Type 1 Kit.																
4A0208A	2	456 (17.95)	960 (37.80)	330 (12.99)	325 (12.80)	7.9 (0.31)	28 (27.76)	680 (26.77)	12 (0.49)	255 (10.04)	-	130 (5.12)	3.3 (0.13)	3.3 (0.13)	M10	87 (191.8)
4A0250A		194 (19.84)	1168 (45.98)	35 (13.78)	370 (14.57)	7.9 (0.31)	800 (31.50)	773 (30.43)	13 (0.51)	368 (14.49)	-	130 (5.12)	4.6 (0.18)	4.6 (0.18)	M12	106 (233.7)
4A0296A		194 (19.84)	1168 (45.98)	35 (13.78)	370 (14.57)	7.9 (0.31)	800 (31.50)	773 (30.43)	13 (0.51)	368 (14.49)	-	130 (5.12)	4.6 (0.18)	4.6 (0.18)	M12	112 (246.9)
4A0362A		194 (19.84)	1168 (45.98)	35 (13.78)	370 (14.57)	7.9 (0.31)	800 (31.50)	773 (30.43)	13 (0.51)	368 (14.49)	-	130 (5.12)	4.6 (0.18)	4.6 (0.18)	M12	117 (257.9)

<1> Removing the top protective cover from an IP20/NEMA 1, UL Type 1 enclosure drive voids NEMA 1, UL Type 1 protection while retaining IP20 conformity.

## 2.1 Mechanical Installation

**Table 2.6 Dimensions for IP20/NEMA 1, UL Type 1 Enclosure: 600 V Class**

Drive Model	Figure	Dimensions mm (in)														Wt. kg (lb)
		W	H	D	W1	W2	H0	H1	H2	H3	H4	D1	t1	t2	d	
5A0003F	1 <1>	140 (5.51)	300 (11.81)	147 (5.79)	122 (4.80)	-	260 (10.24)	248 (9.76)	6 (0.24)	40 (1.57)	1.5 (0.06)	38 (1.50)	5 (0.20)	-	M5	3.4 (7.5)
5A0004F		140 (5.51)	300 (11.81)	147 (5.79)	122 (4.80)	-	260 (10.24)	248 (9.76)	6 (0.24)	40 (1.57)	1.5 (0.06)	38 (1.50)	5 (0.20)	-	M5	3.4 (7.5)
5A0006F		140 (5.51)	300 (11.81)	164 (6.46)	122 (4.80)	-	260 (10.24)	248 (9.76)	6 (0.24)	40 (1.57)	1.5 (0.06)	55 (2.17)	5 (0.20)	-	M5	3.8 (8.2)
5A0009F		140 (5.51)	300 (11.81)	164 (6.46)	122 (4.80)	-	260 (10.24)	248 (9.76)	6 (0.24)	40 (1.57)	1.5 (0.06)	55 (2.17)	5 (0.20)	-	M5	3.8 (8.2)
5A0011F		140 (5.51)	300 (11.81)	167 (6.57)	122 (4.80)	-	260 (10.24)	248 (9.76)	6 (0.24)	40 (1.57)	1.5 (0.06)	55 (2.17)	5 (0.20)	-	M5	4.0 (9.0)
5A0017F		180 (7.09)	340 (13.39)	187 (7.36)	160 (6.30)	-	300 (11.81)	284 (11.18)	7.9 (0.31)	40 (1.57)	1.5 (0.06)	75 (2.95)	5 (0.20)	-	M5	6.0 (13.2)
5A0022F		180 (7.09)	340 (13.39)	187 (7.36)	160 (6.30)	-	300 (11.81)	284 (11.18)	7.9 (0.31)	40 (1.57)	1.5 (0.06)	75 (2.95)	5 (0.20)	-	M5	6.0 (13.2)
5A0027F		220 (8.66)	400 (15.75)	197 (7.76)	192 (7.56)	-	35 (13.78)	335 (13.19)	7.9 (0.31)	50 (1.97)	1.5 (0.06)	78 (3.07)	5 (0.20)	-	M6	8.8 (19.2)
5A0032F		220 (8.66)	400 (15.75)	197 (7.76)	192 (7.56)	-	35 (13.78)	335 (13.19)	7.9 (0.31)	50 (1.97)	1.5 (0.06)	78 (3.07)	5 (0.20)	-	M6	8.8 (19.2)
5A0041F		2	279 (10.98)	515 (20.28)	258 (10.16)	220 (8.66)	7.9 (0.31)	450 (17.72)	435 (17.13)	7.7 (0.30)	65 (2.56)	-	100 (3.94)	2.2 (0.09)	2.2 (0.09)	M6
5A0052F	279 (10.98)		515 (20.28)	258 (10.16)	220 (8.66)	7.9 (0.31)	450 (17.72)	435 (17.13)	7.7 (0.30)	65 (2.56)	-	100 (3.94)	2.2 (0.09)	2.2 (0.09)	M6	27 (59.5)
5A0062F	329 (12.95)		730 (28.74)	283 (11.14)	260 (10.24)	7.9 (0.31)	550 (21.65)	535 (21.06)	7.7 (0.30)	180 (7.09)	-	110 (4.33)	2.2 (0.09)	2.2 (0.09)	M6	45 (99.2)
5A0077F	329 (12.95)		730 (28.74)	283 (11.14)	260 (10.24)	7.9 (0.31)	550 (21.65)	535 (21.06)	7.7 (0.30)	180 (7.09)	-	110 (4.33)	2.2 (0.09)	2.2 (0.09)	M6	45 (99.2)
5A0099F	329 (12.95)		730 (28.74)	283 (11.14)	260 (10.24)	7.9 (0.31)	550 (21.65)	535 (21.06)	7.7 (0.30)	180 (7.09)	-	110 (4.33)	2.2 (0.09)	2.2 (0.09)	M6	45 (99.2)
<b>Dimensions below are the dimensions of IP00/Open Type models after customer installation of the appropriate IP20/NEMA 1, UL Type 1 Kit.</b>																
5A0125A	2	456 (17.95)	960 (37.80)	330 (12.99)	325 (12.80)	7.9 (0.31)	28 (27.76)	680 (26.77)	12 (0.49)	255 (10.04)	-	130 (5.12)	3.3 (0.13)	3.3 (0.13)	M10	87 (191.8)
5A0145A		456 (17.95)	960 (37.80)	330 (12.99)	325 (12.80)	7.9 (0.31)	28 (27.76)	680 (26.77)	12 (0.49)	255 (10.04)	-	130 (5.12)	3.3 (0.13)	3.3 (0.13)	M10	87 (191.8)
5A0192A		194 (19.84)	1168 (45.98)	35 (13.78)	370 (14.57)	7.9 (0.31)	800 (31.50)	773 (30.43)	13 (0.51)	368 (14.49)	-	130 (5.12)	4.6 (0.18)	4.6 (0.18)	M12	106 (233.7)
5A0242A		194 (19.84)	1168 (45.98)	35 (13.78)	370 (14.57)	7.9 (0.31)	800 (31.50)	773 (30.43)	13 (0.51)	368 (14.49)	-	130 (5.12)	4.6 (0.18)	4.6 (0.18)	M12	117 (257.9)

<1> Removing the top protective cover or bottom conduit bracket from an IP20/NEMA 1, UL Type 1 enclosure drive voids NEMA 1, UL Type 1 protection while maintaining IP20 conformity.

IP20/NEMA 1, UL Type 1 Enclosure Conduit Bracket Dimensions

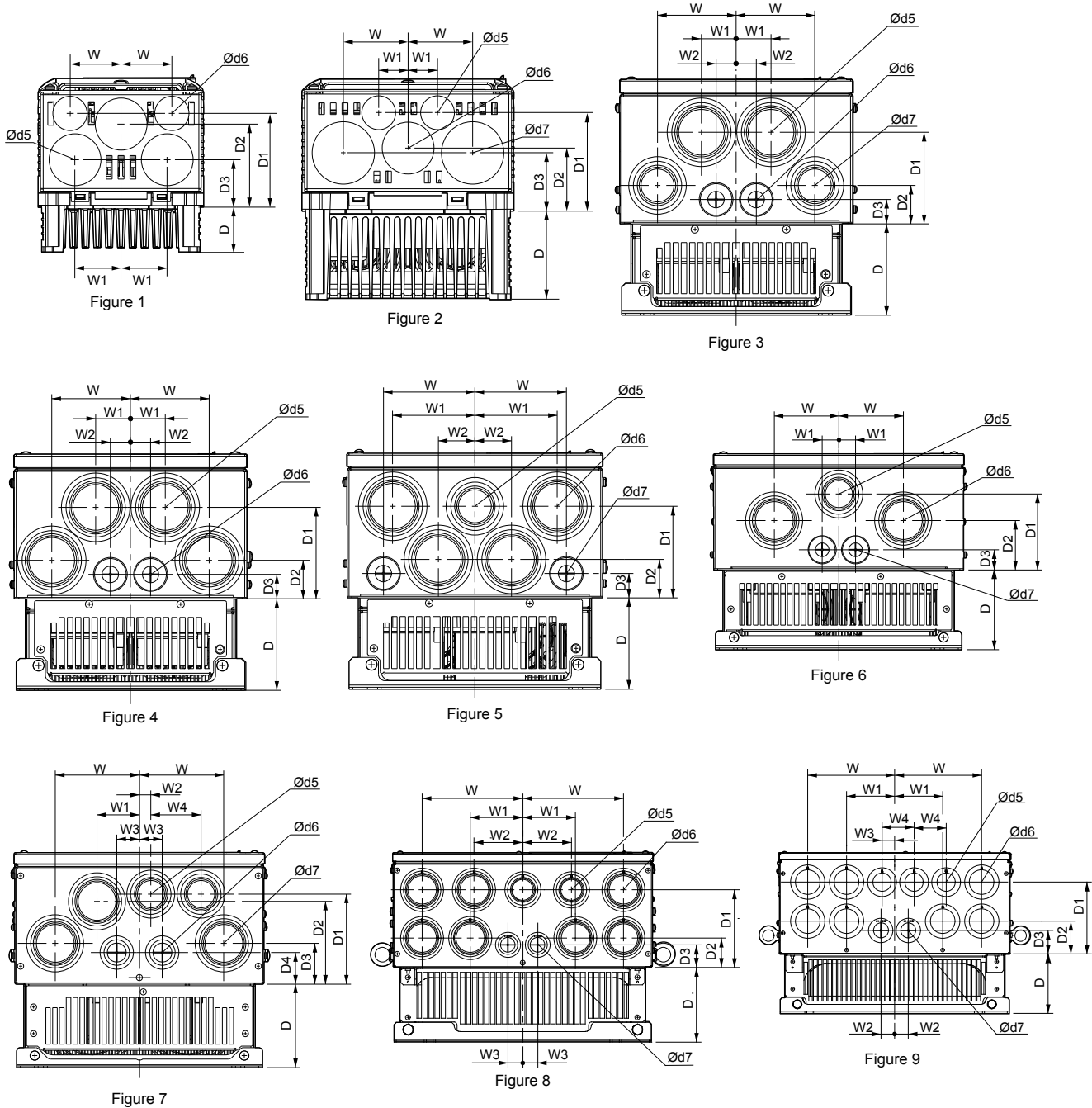

Table 2.7 Conduit Bracket Dimensions for IP20/NEMA 1, UL Type 1

Drive Model	Figure	Dimensions mm (in)										Diameter mm (in)		
		W	D	W1	W2	W3	W4	D1	D2	D3	D4	d5	d6	d7
<b>200 V Class</b>														
2A0004F	1	43 (1.7)	38 (1.5)	38 (1.5)	-	-	-	41 (1.6)	71 (2.8)	79 (3.1)	-	23 (0.9)	36 (1.4)	-
2A0006F		43 (1.7)	38 (1.5)	38 (1.5)	-	-	-	41 (1.6)	71 (2.8)	79 (3.1)	-	23 (0.9)	36 (1.4)	-
2A0008F		43 (1.7)	38 (1.5)	38 (1.5)	-	-	-	41 (1.6)	71 (2.8)	79 (3.1)	-	-	-	-
2A0010F		43 (1.7)	38 (1.5)	38 (1.5)	-	-	-	41 (1.6)	71 (2.8)	79 (3.1)	-	23 (0.9)	36 (1.4)	-
2A0012F		43 (1.7)	56 (2.2)	38 (1.5)	-	-	-	41 (1.6)	71 (2.8)	79 (3.1)	-	23 (0.9)	36 (1.4)	-

## 2.1 Mechanical Installation

Drive Model	Figure	Dimensions mm (in)										Diameter mm (in)		
		W	D	W1	W2	W3	W4	D1	D2	D3	D4	d5	d6	d7
2A0018F	2	43 (1.7)	56 (2.2)	38 (1.5)	-	-	-	41 (1.6)	71 (2.8)	79 (3.1)	-	36 (1.4)	23 (0.9)	43 (1.7)
2A0021F		43 (1.7)	56 (2.2)	38 (1.5)	-	-	-	41 (1.6)	71 (2.8)	79 (3.1)	-	36 (1.4)	23 (0.9)	43 (1.7)
2A0030F		43 (1.7)	56 (2.2)	38 (1.5)	-	-	-	41 (1.6)	71 (2.8)	79 (3.1)	-	36 (1.4)	23 (0.9)	43 (1.7)
2A0040F		25 (1.0)	76 (3.0)	56 (2.2)	-	-	-	48 (1.9)	84 (3.3)	53 (2.1)	-	36 (1.4)	23 (0.9)	43 (1.7)
2A0056F		25 (1.0)	76 (3.0)	56 (2.2)	-	-	-	48 (1.9)	84 (3.3)	53 (2.1)	-	36 (1.4)	23 (0.9)	43 (1.7)
2A0069F		28 (1.1)	79 (3.1)	64 (2.5)	-	-	-	51 (2.0)	86 (3.4)	56 (2.2)	-	36 (1.4)	23 (0.9)	43 (1.7)
2A0081F		28 (1.1)	79 (3.1)	64 (2.5)	-	-	-	51 (2.0)	86 (3.4)	56 (2.2)	-	36 (1.4)	23 (0.9)	43 (1.7)
2A0110F	4	86 (3.4)	99 (3.9)	38 (1.5)	23 (0.9)	-	-	99 (3.9)	43 (1.7)	25 (1.0)	-	61 (2.4)	28 (1.1)	-
2A0138F	5	99 (3.9)	99 (3.9)	89 (3.5)	41 (1.6)	-	-	99 (3.9)	43 (1.7)	25 (1.0)	-	51 (2.0)	61 (2.4)	28 (1.1)
2A0169F	7	111 (4.4)	109 (4.3)	56 (2.2)	15 (0.6)	30 (1.2)	66 (2.6)	119 (4.7)	109 (4.3)	53 (2.1)	41 (1.6)	51 (2.0)	36 (1.4)	61 (2.4)
2A0211F		111 (4.4)	109 (4.3)	56 (2.2)	15 (0.6)	30 (1.2)	66 (2.6)	119 (4.7)	109 (4.3)	53 (2.1)	41 (1.6)	51 (2.0)	36 (1.4)	61 (2.4)
2A0250A	8	175 (6.9)	130 (5.1)	91 (3.6)	84 (3.3)	25 (1.0)	-	137 (5.4)	51 (2.0)	41 (1.6)	-	51 (2.0)	61 (2.4)	36 (1.4)
2A0312A		175 (6.9)	130 (5.1)	91 (3.6)	84 (3.3)	25 (1.0)	-	137 (5.4)	51 (2.0)	41 (1.6)	-	51 (2.0)	61 (2.4)	36 (1.4)
2A0360A	9	191 (7.5)	130 (5.1)	104 (4.1)	30 (1.2)	28 (1.1)	71 (2.8)	157 (6.2)	71 (2.8)	51 (2.0)	-	51 (2.0)	61 (2.4)	43 (1.7)
<b>400 V Class</b>														
4A0002F	1	43 (1.7)	38 (1.5)	38 (1.5)	-	-	-	41 (1.6)	71 (2.8)	79 (3.1)	-	23 (0.9)	36 (1.4)	-
4A0004F		43 (1.7)	38 (1.5)	38 (1.5)	-	-	-	41 (1.6)	71 (2.8)	79 (3.1)	-	23 (0.9)	36 (1.4)	-
4A0005F		43 (1.7)	38 (1.5)	38 (1.5)	-	-	-	41 (1.6)	71 (2.8)	79 (3.1)	-	23 (0.9)	36 (1.4)	-
4A0007F		43 (1.7)	56 (2.2)	38 (1.5)	-	-	-	41 (1.6)	71 (2.8)	79 (3.1)	-	23 (0.9)	36 (1.4)	-
4A0009F		43 (1.7)	56 (2.2)	38 (1.5)	-	-	-	41 (1.6)	71 (2.8)	79 (3.1)	-	23 (0.9)	36 (1.4)	-
4A0011F		43 (1.7)	56 (2.2)	38 (1.5)	-	-	-	41 (1.6)	71 (2.8)	79 (3.1)	-	23 (0.9)	36 (1.4)	-
4A0018F		43 (1.7)	56 (2.2)	38 (1.5)	-	-	-	41 (1.6)	71 (2.8)	79 (3.1)	-	23 (0.9)	36 (1.4)	-
4A0023F	2	25 (1.0)	76 (3.0)	56 (2.2)	-	-	-	48 (1.9)	84 (3.3)	53 (2.1)	-	36 (1.4)	23 (0.9)	43 (1.7)
4A0031F		25 (1.0)	76 (3.0)	56 (2.2)	-	-	-	48 (1.9)	84 (3.3)	53 (2.1)	-	36 (1.4)	23 (0.9)	43 (1.7)
4A0038F		28 (1.1)	79 (3.1)	64 (2.5)	-	-	-	51 (2.0)	86 (3.4)	56 (2.2)	-	36 (1.4)	23 (0.9)	43 (1.7)
4A0044F		28 (1.1)	79 (3.1)	64 (2.5)	-	-	-	51 (2.0)	86 (3.4)	56 (2.2)	-	36 (1.4)	23 (0.9)	43 (1.7)
4A0058F	3	86 (3.4)	99 (3.9)	38 (1.5)	23 (0.9)	-	-	99 (3.9)	43 (1.7)	25 (1.0)	-	61 (2.4)	28 (1.1)	51 (2.0)
4A0072F		89 (3.5)	99 (3.9)	41 (1.6)	23 (0.9)	-	-	99 (3.9)	43 (1.7)	25 (1.0)	-	61 (2.4)	28 (1.1)	51 (2.0)
4A0088F	6	84 (3.3)	104 (4.1)	23 (0.9)	-	-	-	99 (3.9)	66 (2.6)	25 (1.0)	-	51 (2.0)	61 (2.4)	28 (1.1)
4A0103F		84 (3.3)	104 (4.1)	23 (0.9)	-	-	-	99 (3.9)	66 (2.6)	25 (1.0)	-	51 (2.0)	61 (2.4)	28 (1.1)



Drive Model	Figure	Dimensions mm (in)										Diameter mm (in)		
		W	D	W1	W2	W3	W4	D1	D2	D3	D4	d5	d6	d7
4A0139F	7	111 (4.4)	109 (4.3)	56 (2.2)	15 (0.6)	30 (1.2)	66 (2.6)	119 (4.7)	109 (4.3)	53 (2.1)	41 (1.6)	51 (2.0)	36 (1.4)	61 (2.4)
4A0165F		111 (4.4)	109 (4.3)	56 (2.2)	15 (0.6)	30 (1.2)	66 (2.6)	119 (4.7)	109 (4.3)	53 (2.1)	41 (1.6)	51 (2.0)	36 (1.4)	61 (2.4)
4A0208A	8	175 (6.9)	130 (5.1)	91 (3.6)	84 (3.3)	25 (1.0)	–	137 (5.4)	51 (2.0)	41 (1.6)	–	51 (2.0)	61 (2.4)	36 (1.4)
4A0250A	9	191 (7.5)	130 (5.1)	104 (4.1)	30 (1.2)	28 (1.1)	71 (2.8)	157 (6.2)	71 (2.8)	51 (2.0)	–	51 (2.0)	61 (2.4)	43 (1.7)
4A0296A		191 (7.5)	130 (5.1)	104 (4.1)	30 (1.2)	28 (1.1)	71 (2.8)	157 (6.2)	71 (2.8)	51 (2.0)	–	51 (2.0)	61 (2.4)	43 (1.7)
4A0362A		191 (7.5)	130 (5.1)	104 (4.1)	30 (1.2)	28 (1.1)	71 (2.8)	157 (6.2)	71 (2.8)	51 (2.0)	–	51 (2.0)	61 (2.4)	43 (1.7)
<b>600 V Class</b>														
5A0003F	1	43 (1.7)	38 (1.5)	38 (1.5)	–	–	–	41 (1.6)	71 (2.8)	79 (3.1)	–	23 (0.9)	36 (1.4)	–
5A0004F		43 (1.7)	38 (1.5)	38 (1.5)	–	–	–	41 (1.6)	71 (2.8)	79 (3.1)	–	23 (0.9)	36 (1.4)	–
5A0006F		43 (1.7)	56 (2.2)	38 (1.5)	–	–	–	41 (1.6)	71 (2.8)	79 (3.1)	–	23 (0.9)	36 (1.4)	–
5A0009F		43 (1.7)	56 (2.2)	38 (1.5)	–	–	–	41 (1.6)	71 (2.8)	79 (3.1)	–	23 (0.9)	36 (1.4)	–
5A0011F		43 (1.7)	56 (2.2)	38 (1.5)	–	–	–	41 (1.6)	71 (2.8)	79 (3.1)	–	23 (0.9)	36 (1.4)	–
5A0017F	2	25 (1.0)	76 (3.0)	56 (2.2)	–	–	–	48 (1.9)	84 (3.3)	53 (2.1)	–	36 (1.4)	23 (0.9)	43 (1.7)
5A0022F		25 (1.0)	76 (3.0)	56 (2.2)	–	–	–	48 (1.9)	84 (3.3)	53 (2.1)	–	36 (1.4)	23 (0.9)	43 (1.7)
5A0027F		28 (1.1)	79 (3.1)	64 (2.5)	–	–	–	51 (2.0)	86 (3.4)	56 (2.2)	–	36 (1.4)	23 (0.9)	43 (1.7)
5A0032F		28 (1.1)	79 (3.1)	64 (2.5)	–	–	–	51 (2.0)	86 (3.4)	56 (2.2)	–	36 (1.4)	23 (0.9)	43 (1.7)
5A0041F	3	89 (3.5)	99 (3.9)	41 (1.6)	23 (0.9)	–	–	99 (3.9)	43 (1.7)	25 (1.0)	–	61 (2.4)	28 (1.1)	51 (2.0)
5A0052F		89 (3.5)	99 (3.9)	41 (1.6)	23 (0.9)	–	–	99 (3.9)	43 (1.7)	25 (1.0)	–	61 (2.4)	28 (1.1)	51 (2.0)
5A0062F	7	111 (4.4)	109 (4.3)	56 (2.2)	15 (0.6)	30 (1.2)	66 (2.6)	119 (4.7)	109 (4.3)	53 (2.1)	41 (1.6)	51 (2.0)	36 (1.4)	61 (2.4)
5A0077F		111 (4.4)	109 (4.3)	56 (2.2)	15 (0.6)	30 (1.2)	66 (2.6)	119 (4.7)	109 (4.3)	53 (2.1)	41 (1.6)	51 (2.0)	36 (1.4)	61 (2.4)
5A0099F		111 (4.4)	109 (4.3)	56 (2.2)	15 (0.6)	30 (1.2)	66 (2.6)	119 (4.7)	109 (4.3)	53 (2.1)	41 (1.6)	51 (2.0)	36 (1.4)	61 (2.4)
5A0125A	8	175 (6.9)	130 (5.1)	91 (3.6)	84 (3.3)	25 (1.0)	–	137 (5.4)	51 (2.0)	41 (1.6)	–	51 (2.0)	61 (2.4)	36 (1.4)
5A0145A		175 (6.9)	130 (5.1)	91 (3.6)	84 (3.3)	25 (1.0)	–	137 (5.4)	51 (2.0)	41 (1.6)	–	51 (2.0)	61 (2.4)	36 (1.4)
5A0192A	9	191 (7.5)	130 (5.1)	104 (4.1)	30 (1.2)	28 (1.1)	71 (2.8)	157 (6.2)	71 (2.8)	51 (2.0)	–	51 (2.0)	61 (2.4)	43 (1.7)
5A0242A		191 (7.5)	130 (5.1)	104 (4.1)	30 (1.2)	28 (1.1)	71 (2.8)	157 (6.2)	71 (2.8)	51 (2.0)	–	51 (2.0)	61 (2.4)	43 (1.7)

**Note:** Removing the top protective cover or bottom conduit bracket from an IP20/NEMA 1, UL Type 1 enclosure drive voids NEMA 1, UL Type 1 protection while maintaining IP20 conformity.

## 2.1 Mechanical Installation

### ■ IP00/Open Type Enclosure Drives

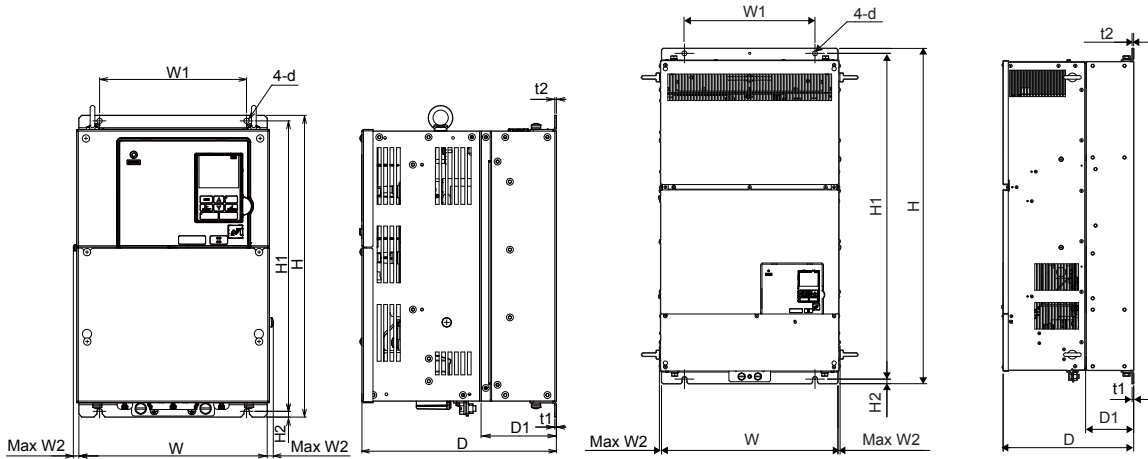

Figure 1

Figure 2

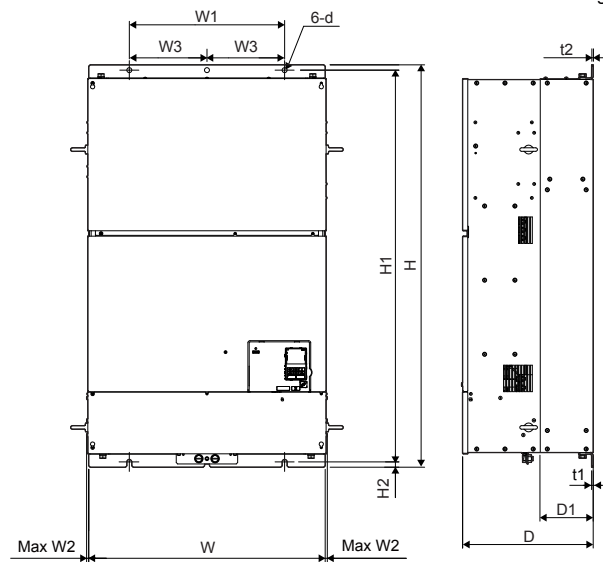

Figure 3

Table 2.8 Dimensions for IP00/Open Type Enclosure: 200 V Class

Drive Model	Dimensions (in)												
	Figure	W	H	D	W1	W2	H1	H2	D1	t1	t2	d	Wt. (lb)
2A0250A <1>	1	450 (17.72)	705 (27.76)	330 (12.99)	325 (12.80)	10 (0.39)	680 (26.77)	12 (0.49)	130 (5.12)	3 (0.13)	3 (0.13)	M10	76 (167.6)
2A0312A <1>		450 (17.72)	705 (27.76)	330 (12.99)	325 (12.80)	10 (0.39)	680 (26.77)	12 (0.49)	130 (5.12)	3 (0.13)	3 (0.13)	M10	80 (176.4)
2A0360A <1>		500 (19.69)	800 (31.50)	350 (13.78)	370 (14.57)	10 (0.39)	773 (30.43)	13 (0.51)	130 (5.12)	5 (0.18)	5 (0.18)	M12	98 (216.1)
2A0415A		500 (19.69)	800 (31.50)	350 (13.78)	370 (14.57)	10 (0.39)	773 (30.43)	13 (0.51)	130 (5.12)	5 (0.18)	5 (0.18)	M12	99 (218.3)

<1> Customers may convert these models to IP20/NEMA 1, UL Type 1 enclosures using an IP20/NEMA 1, UL Type 1 Kit. [Refer to IP20/NEMA 1, UL Type 1 Kit Selection on page 52](#) to select the appropriate kit.

Table 2.9 Dimensions for IP00/Open Type Enclosure: 400 V Class

Drive Model	Dimensions (in)														
	Figure	W	H	D	W1	W2	W3	W4	H1	H2	D1	t1	t2	d	Wt. (lb)
4A0208A <I>	1	450 (17.72)	705 (27.76)	330 (12.99)	325 (12.80)	10 (0.39)	-	-	680 (26.77)	12 (0.49)	130 (5.12)	3 (0.13)	3 (0.13)	M10	79 (174.2)
4A0250A <I>		500 (19.69)	800 (31.50)	350 (13.78)	370 (14.57)	10 (0.39)	-	-	773 (30.43)	13 (0.51)	130 (5.12)	5 (0.18)	5 (0.18)	M12	96 (211.6)
4A0296A <I>		500 (19.69)	800 (31.50)	350 (13.78)	370 (14.57)	10 (0.39)	-	-	73 (30.43)	13 (0.51)	130 (5.12)	5 (0.18)	5 (0.18)	M12	102 (224.9)
4A0362A <I>		500 (19.69)	800 (31.50)	350 (13.78)	370 (14.57)	10 (0.39)	-	-	73 (30.43)	13 (0.51)	130 (5.12)	5 (0.18)	5 (0.18)	M12	107 (235.9)
4A0414A	2	500 (19.69)	950 (37.40)	370 (14.57)	370 (14.57)	8 (0.31)	-	-	923 (36.34)	13 (0.51)	135 (5.31)	5 (0.18)	5 (0.18)	M12	125 (275.6)
4A0515A	3	670 (26.38)	1140 (44.88)	370 (14.57)	440 (17.32)	610 (0.24)	220 (8.66)	-	1110 (43.70)	15 (0.59)	150 (5.91)	5 (0.18)	5 (0.18)	M12	216 (476.2)
4A0675A		670 (26.38)	1140 (44.88)	370 (14.57)	440 (17.32)	610 (0.24)	220 (8.66)	-	1110 (43.70)	15 (0.59)	150 (5.91)	5 (0.18)	5 (0.18)	M12	221 (487.2)
4A0930A	4	1250 (49.21)	1380 (54.33)	370 (14.57)	1110 (43.70)	6 (0.24)	330 (13.00)	440 (17.32)	1345 (52.95)	15 (0.59)	150 (5.91)	4.6 (0.18)	4.6 (0.18)	M12	545 (1201.5)
4A1200A	4	1250 (49.21)	1380 (54.33)	370 (14.57)	1110 (43.70)	6 (0.24)	330 (13.00)	440 (17.32)	1345 (52.95)	15 (0.59)	150 (5.91)	4.6 (0.18)	4.6 (0.18)	M12	555 (1223.6)

<I> Customers may convert these models to IP20/NEMA 1, UL Type 1 enclosures using an IP20/NEMA 1, UL Type 1 Kit. Refer to IP20/NEMA 1, UL Type 1 Kit Selection on page 52 to select the appropriate kit.

Table 2.10 Dimensions for IP00/Open Type Enclosure: 600 V Class

Drive Model	Dimensions (in)														
	Figure	W	H	D	W1	W2	W3	W4	H1	H2	D1	t1	t2	d	Wt. (lb)
5A0125A <I>	1	450 (17.72)	705 (27.76)	330 (12.99)	325 (12.80)	10 (0.39)	-	-	680 (26.77)	12 (0.49)	130 (5.12)	3 (0.13)	3 (0.13)	M10	79 (174.2)
5A0145A <I>		450 (17.72)	705 (27.76)	330 (12.99)	325 (12.80)	10 (0.39)	-	-	680 (26.77)	12 (0.49)	130 (5.12)	3 (0.13)	3 (0.13)	M10	79 (174.2)
5A0192A <I>		500 (19.69)	800 (31.50)	350 (13.78)	370 (14.57)	10 (0.39)	-	-	73 (30.43)	13 (0.51)	130 (5.12)	5 (0.18)	5 (0.18)	M12	107 (235.9)
5A0242A <I>		500 (19.69)	800 (31.50)	350 (13.78)	370 (14.57)	10 (0.39)	-	-	73 (30.43)	13 (0.51)	130 (5.12)	5 (0.18)	5 (0.18)	M12	107 (235.9)

<I> Customers may convert these models to IP20/NEMA 1, UL Type 1 enclosures using an IP20/NEMA 1, UL Type 1 Kit. Refer to IP20/NEMA 1, UL Type 1 Kit Selection on page 52 to select the appropriate kit.

## 2.1 Mechanical Installation

### IP20/NEMA 1, UL Type 1 Kit Selection

Customers may convert IP00/Open Type models to IP20/NEMA 1, UL Type 1 enclosures. Refer to [Table 2.11](#) to select the appropriate IP20/NEMA 1, UL Type 1 Kit when performing the conversion.

Contact a Yaskawa representative for IP20/NEMA 1, UL Type 1 Kit availability for IP00/Open Type models not listed.

**Table 2.11 IP20/NEMA 1, UL Type 1 Kit Selection**

IP00/Open Type Drive Model	IP20/NEMA 1, UL Type 1 Kit Code	Comments
2A0250A	100-054-503	<i>Refer to IP20/NEMA 1, UL Type 1 Enclosure Drives on page 44 for drive dimensions with the IP20/NEMA 1, UL Type 1 Kit installed.</i>
2A0312A		
2A0360A		
4A0208A		
4A0250A	100-054-504	
4A0296A		
4A0362A		
5A0125A	100-054-503	
5A0145A		
5A0192A	100-054-504	
5A0242A		

## 2.2 Flange Type Enclosure (NEMA 12 Backside) Dimensions & Heat Loss

### NOTICE

Refer to the iQpump1000 6-Phase/12-Pulse Input Installation Manual TOEPAIP1W03 for information on 12-pulse Flange and non-Flange models. This manual is posted on the Yaskawa website, [www.yaskawa.com](http://www.yaskawa.com).

### ◆ Flange Type Models 2A0004 to 2A0012, 4A0002 to 4A0005, and 5A0003 and 5A0004

#### ■ Flange Type Exterior and Mounting Dimensions

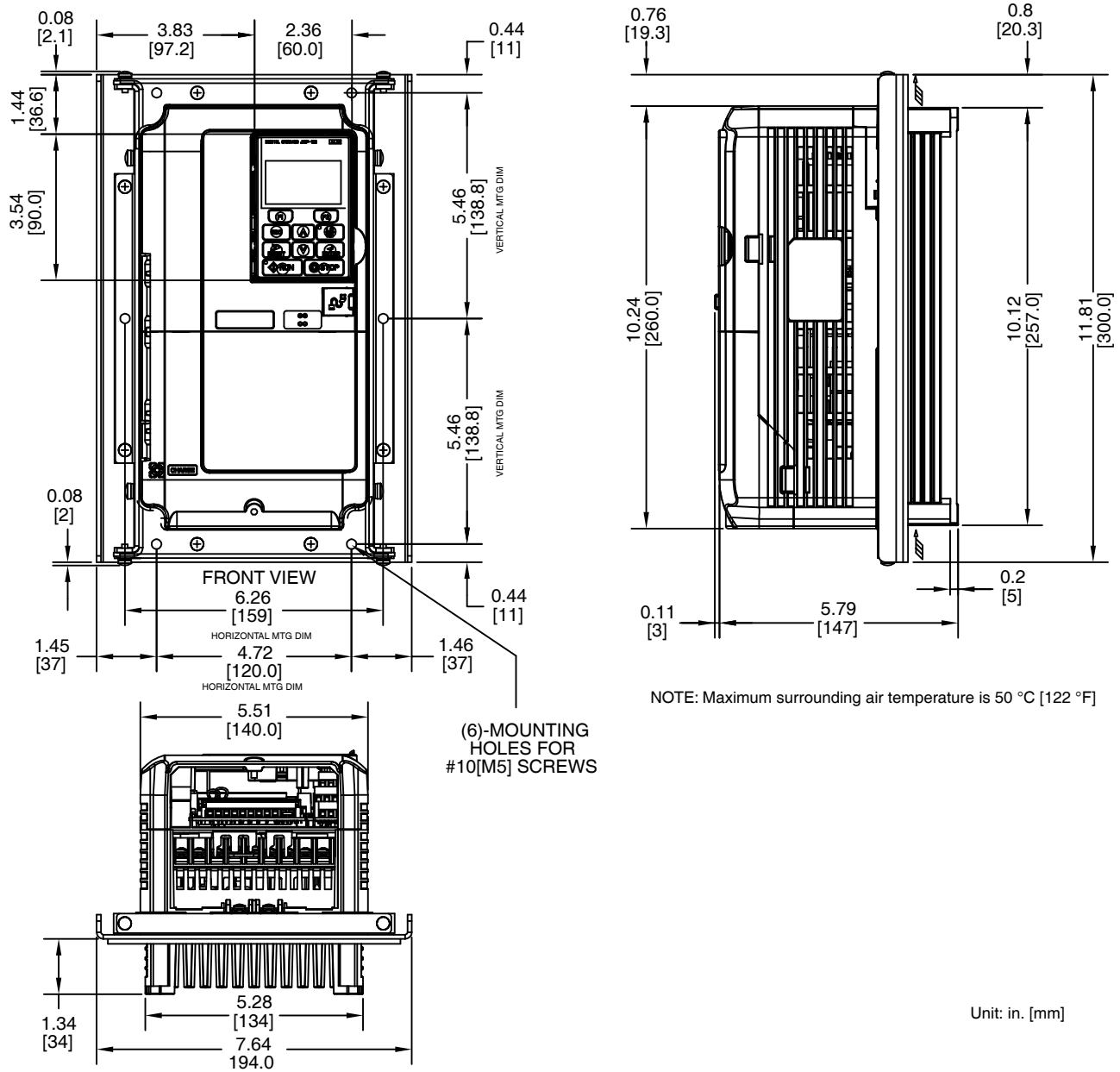

Figure 2.15 Models 2A0004 to 2A0012, 4A0002 to 4A0005, and 5A0003 and 5A0004

## 2.2 Flange Type Enclosure (NEMA 12 Backside) Dimensions & Heat Loss

### ■ Flange Type Heat Loss Data

Table 2.12 Models 2A0004 to 2A0012, 4A0002 to 4A0005, and 5A0003 and 5A0004

Drive Model	Voltage Class	Heat Loss (W)						Wt. kg (lb)
		ND (Fc = 2 kHz)			HD (Fc = 8 kHz)			
		Internal	External	Total	Internal	External	Total	
2A0004	200	47.3	18.4	65.7	44.4	14.8	59.2	3.3 (7.3)
2A0006		51.4	30.8	82.2	47.6	24.1	71.7	3.3 (7.3)
2A0008		52.1	42.9	95.0	48.9	34.8	83.7	3.4 (7.5)
2A0010		58.4	56.7	115.1	52.1	42.9	95.0	3.4 (7.5)
2A0012		64.4	76.9	141.3	57.9	63.7	121.6	3.4 (7.5)

Drive Model	Voltage Class	Heat Loss (W)						Wt. kg (lb)
		ND (Fc = 2 kHz)			HD (Fc = 8 kHz)			
		Internal	External	Total	Internal	External	Total	
4A0002	400	47.9	19.8	67.7	44.7	15.9	60.6	3.4 (7.5)
4A0004		49.2	32.1	81.3	45.7	24.6	70.3	3.4 (7.5)
4A0005		52.8	44.6	97.4	49.4	37.4	86.8	3.4 (7.5)

Drive Model	Voltage Class	Heat Loss (W)						Wt. kg (lb)
		ND (Fc = 2 kHz)			HD (Fc = 8 kHz)			
		Internal	External	Total	Internal	External	Total	
5A0003	600	23.3	21.5	44.8	19.8	28.9	48.7	3.4 (7.5)
5A0004		33.6	27.5	61.1	27.6	54.3	81.9	3.4 (7.5)

■ Flange Type Panel Cutout Dimensions for External Heatsink Mounting

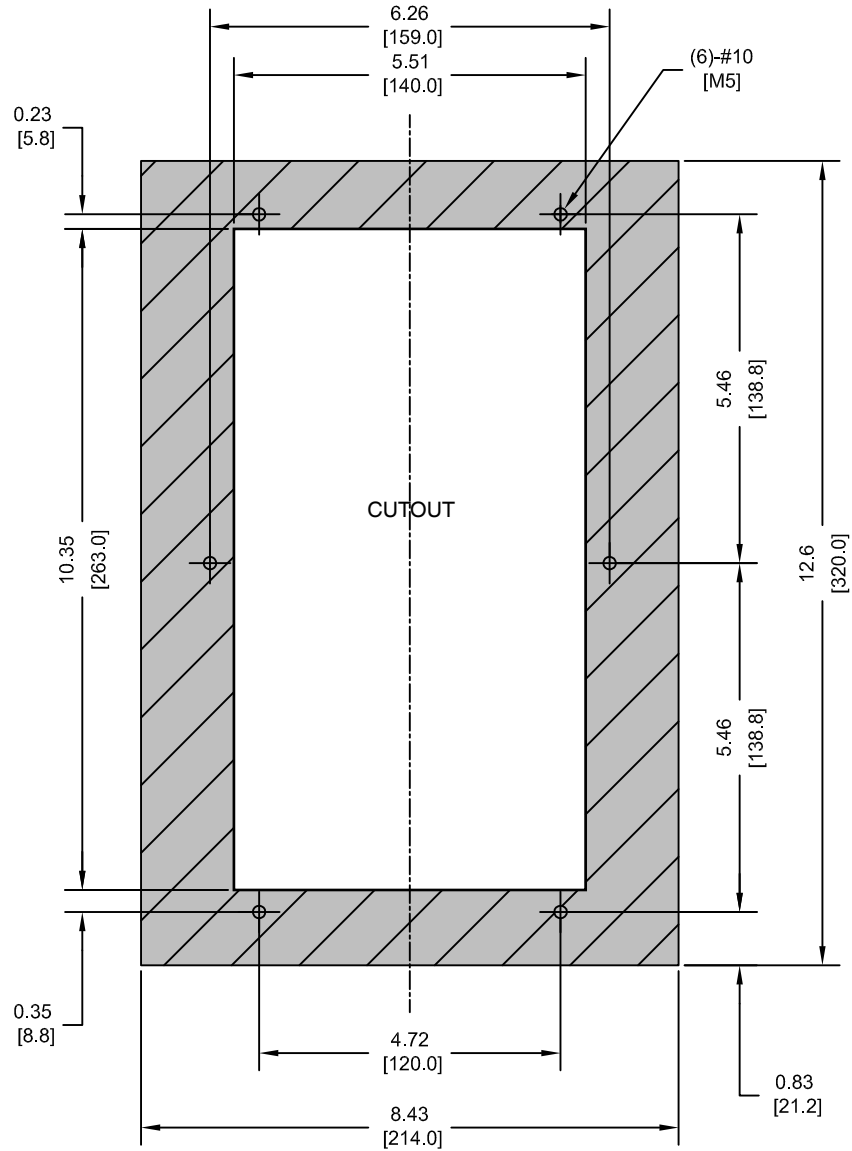

- NOTES:  
 1. CUTOUT TOLERANCES:  
 +/- 0.02 in. [0.5 mm]  
 2. EXPOSED HEATSINK  
 RECOMMENDED CLEARANCE  
 D=1.97 in. [50 mm] MINUS PANEL THICKNESS  
 Unit: in. [mm]

Figure 2.16 Models 2A0004 to 2A0012, 4A0002 to 4A0005, and 5A0003 and 5A0004

## 2.2 Flange Type Enclosure (NEMA 12 Backside) Dimensions & Heat Loss

### ◆ Flange Type Models 2A0018 and 2A0021, 4A0007 to 4A0011, and 5A0006 and 5A0009

#### ■ Flange Type Exterior and Mounting Dimensions

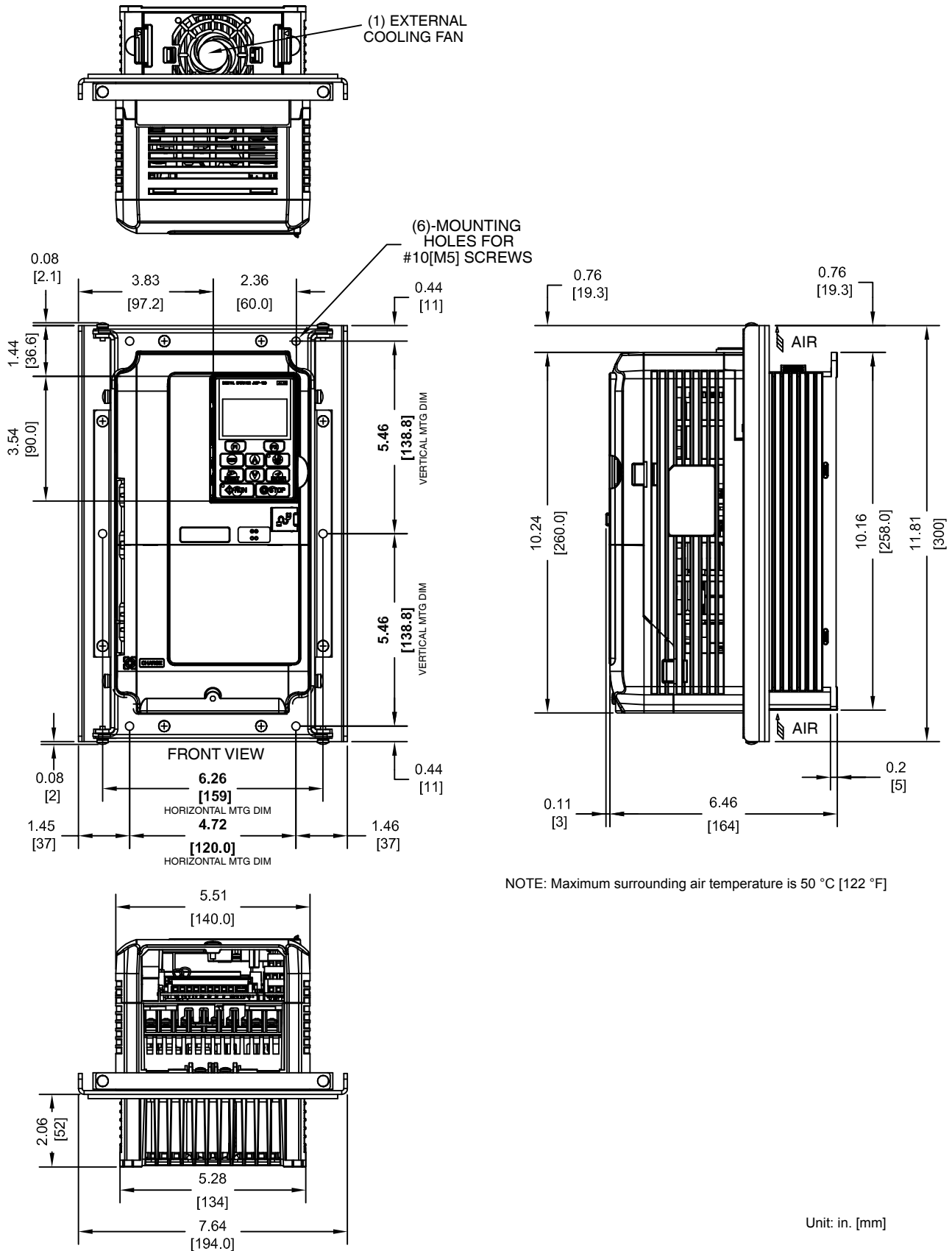

Figure 2.17 Models 2A0018 and 2A0021, 4A0007 to 4A0011, and 5A0006 and 5A0009



■ Flange Type Heat Loss Data

Table 2.13 Models 2A0018 and 2A0021, 4A0007 to 4A0011, and 5A0006 and 5A0009

Drive Model	Voltage Class	Heat Loss (W)						Wt. kg (lb)
		ND (Fc = 2 kHz)			HD (Fc = 8 kHz)			
		Internal	External	Total	Internal	External	Total	
2A0018	200	67.4	100.7	168.1	60.0	77.0	137.0	3.7 (8.1)
2A0021		83.3	138.4	221.7	67.4	100.7	168.1	3.7 (8.1)

Drive Model	Voltage Class	Heat Loss (W)						Wt. kg (lb)
		ND (Fc = 2 kHz)			HD (Fc = 8 kHz)			
		Internal	External	Total	Internal	External	Total	
4A0007	400	59.0	62.1	121.1	53.0	47.7	100.7	3.6 (7.9)
4A0009		60.4	65.8	126.2	55.3	53.1	108.4	3.7 (8.1)
4A0011		73.0	88.7	161.7	61.0	68.5	129.5	3.7 (8.1)

Drive Model	Voltage Class	Heat Loss (W)						Wt. kg (lb)
		ND (Fc = 2 kHz)			HD (Fc = 8 kHz)			
		Internal	External	Total	Internal	External	Total	
5A0006	600	43.7	28.1	71.8	27.0	53.0	80.0	3.7 (8.1)
5A0009		68.9	43.4	112.3	36.4	78.7	115.1	3.7 (8.1)

■ Flange Type Panel Cutout Dimensions for External Heatsink Mounting

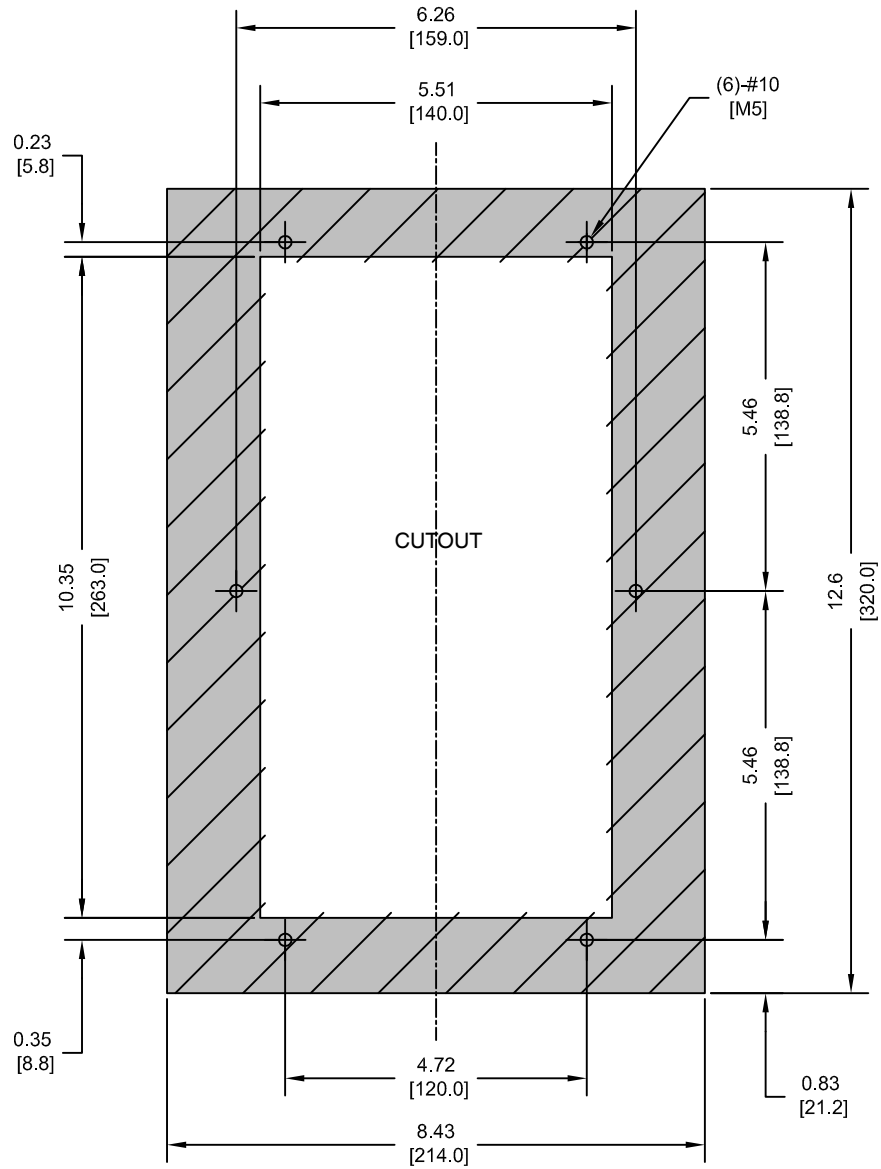

NOTES:

1. CUTOUT TOLERANCES:  
+/- 0.02 in. [0.5 mm]
2. EXPOSED HEATSINK  
RECOMMENDED CLEARANCE  
D=2.36 in. MINUS PANEL THICKNESS

Unit: in. [mm]

Figure 2.18 Models 2A0018 and 2A0021, 4A0007 to 4A0011, and 5A0006 and 5A0009

◆ Flange Type Models 2A0030 and 2A0040, 4A0018 and 4A0023, and 5A0011

■ Flange Type Exterior and Mounting Dimensions

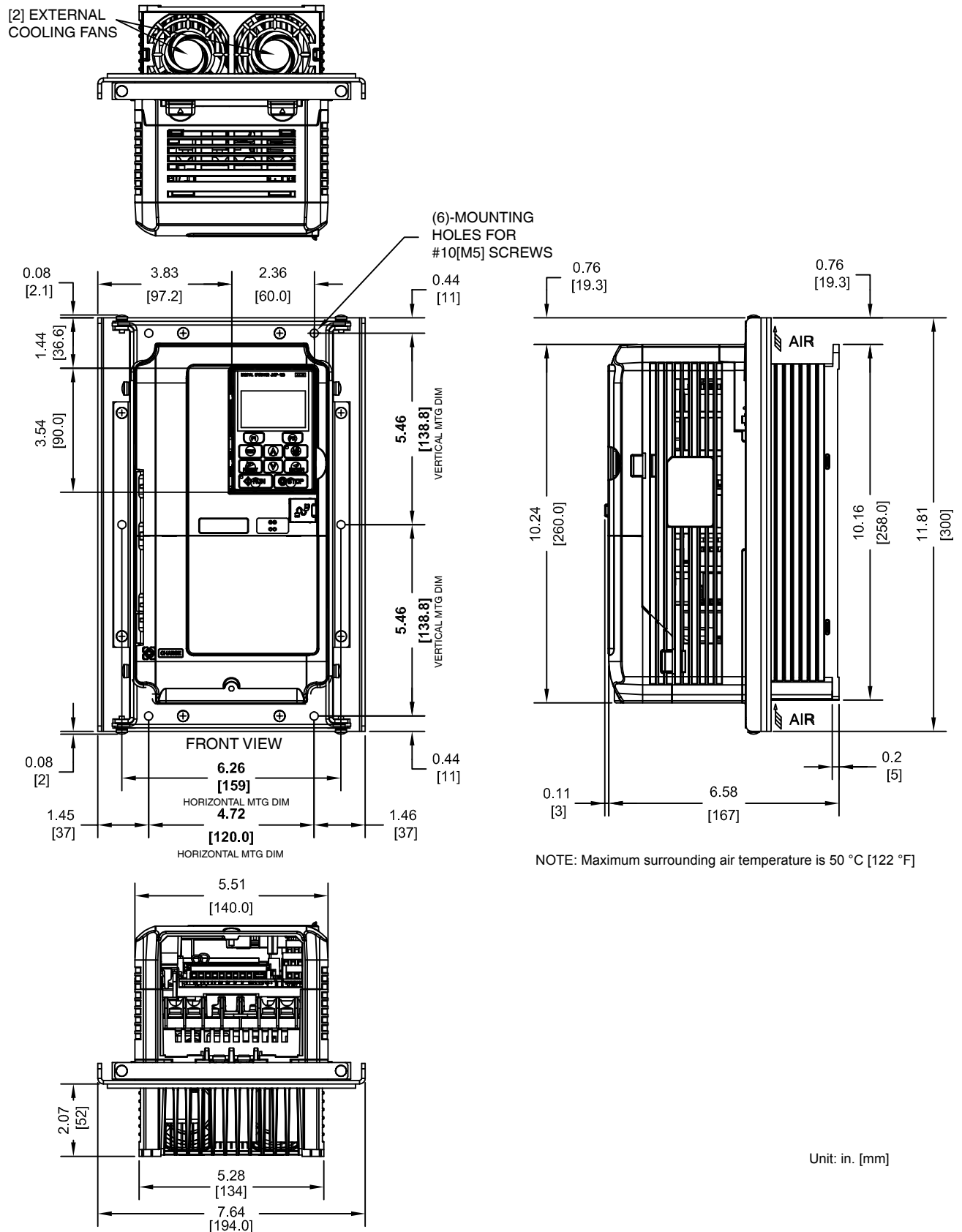

NOTE: Maximum surrounding air temperature is 50 °C [122 °F]

Figure 2.19 Models 2A0030 and 2A0040, 4A0018 and 4A0023, and 5A0011

## 2.2 Flange Type Enclosure (NEMA 12 Backside) Dimensions & Heat Loss

### ■ Flange Type Heat Loss Data

Table 2.14 Models 2A0030 and 2A0040, 4A0018 and 4A0023, and 5A0011

Drive Model	Voltage Class	Heat Loss (W)						Wt. kg (lb)
		ND (Fc = 2 kHz)			HD (Fc = 8 kHz)			
		Internal	External	Total	Internal	External	Total	
2A0030	200	117.1	261.5	378.6	92.3	194.4	286.7	4.2 (9.2)
2A0040		144.5	292.8	437.3	104.8	213.8	318.6	4.2 (9.2)

Drive Model	Voltage Class	Heat Loss (W)						Wt. kg (lb)
		ND (Fc = 2 kHz)			HD (Fc = 8 kHz)			
		Internal	External	Total	Internal	External	Total	
4A0018	400	108.0	177.3	285.3	85.7	135.4	221.1	4.1 (9.0)
4A0023		138.1	215.9	354.0	97.0	149.9	246.9	4.1 (9.0)

Drive Model	Voltage Class	Heat Loss (W)						Wt. kg (lb)
		ND (Fc = 2 kHz)			HD (Fc = 8 kHz)			
		Internal	External	Total	Internal	External	Total	
5A0011	600	88.0	56.1	144.1	49.5	110.9	160.4	4.1 (9.0)

■ Flange Type Panel Cutout Dimensions for External Heatsink Mounting

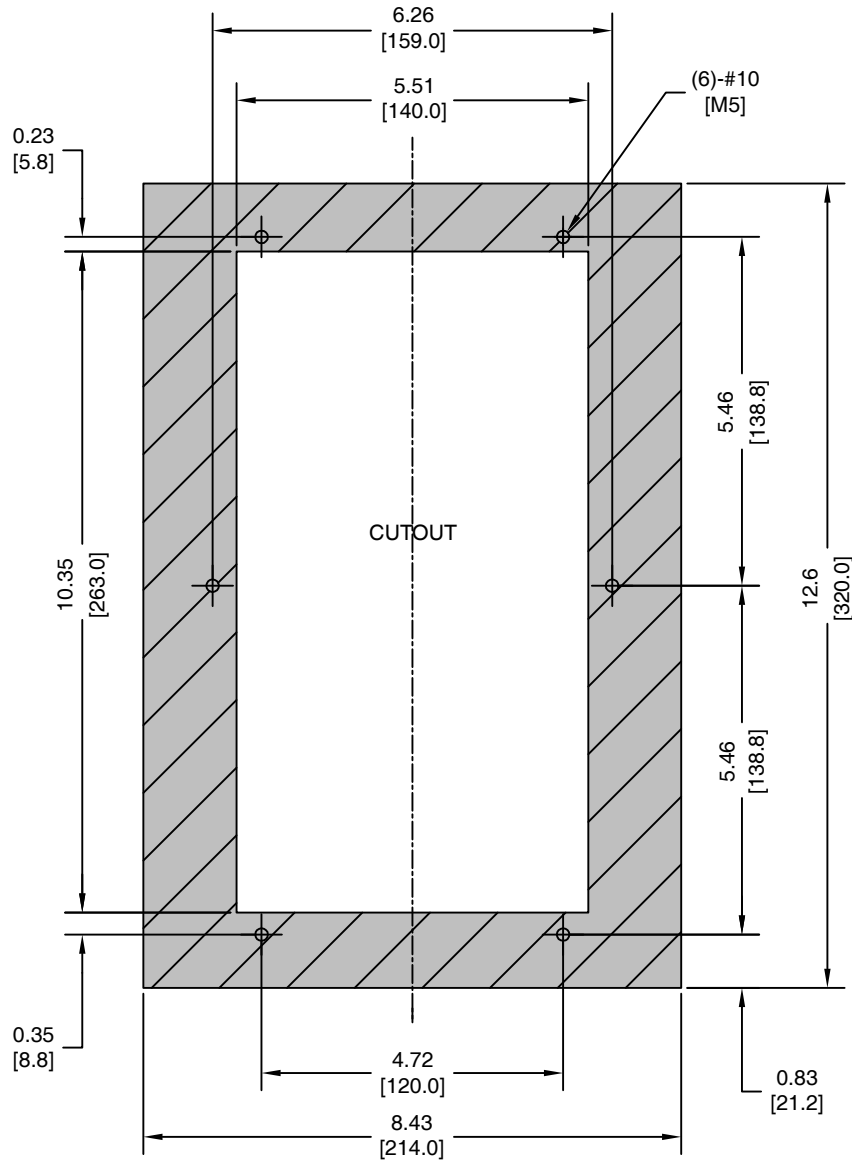

NOTES:

1. CUTOUT TOLERANCES:  
=/- 0.02 in. [0.5 mm]
  2. EXPOSED HEATSINK  
RECOMMENDED CLEARANCE  
D=2.36 in. [60 mm] MINUS PANEL THICKNESS
- Unit: in. [mm]

Figure 2.20 Models 2A0030 and 2A0040, 4A0018 and 4A0023, and 5A0011

◆ Flange Type Model 4A0031

■ Flange Type Exterior and Mounting Dimensions

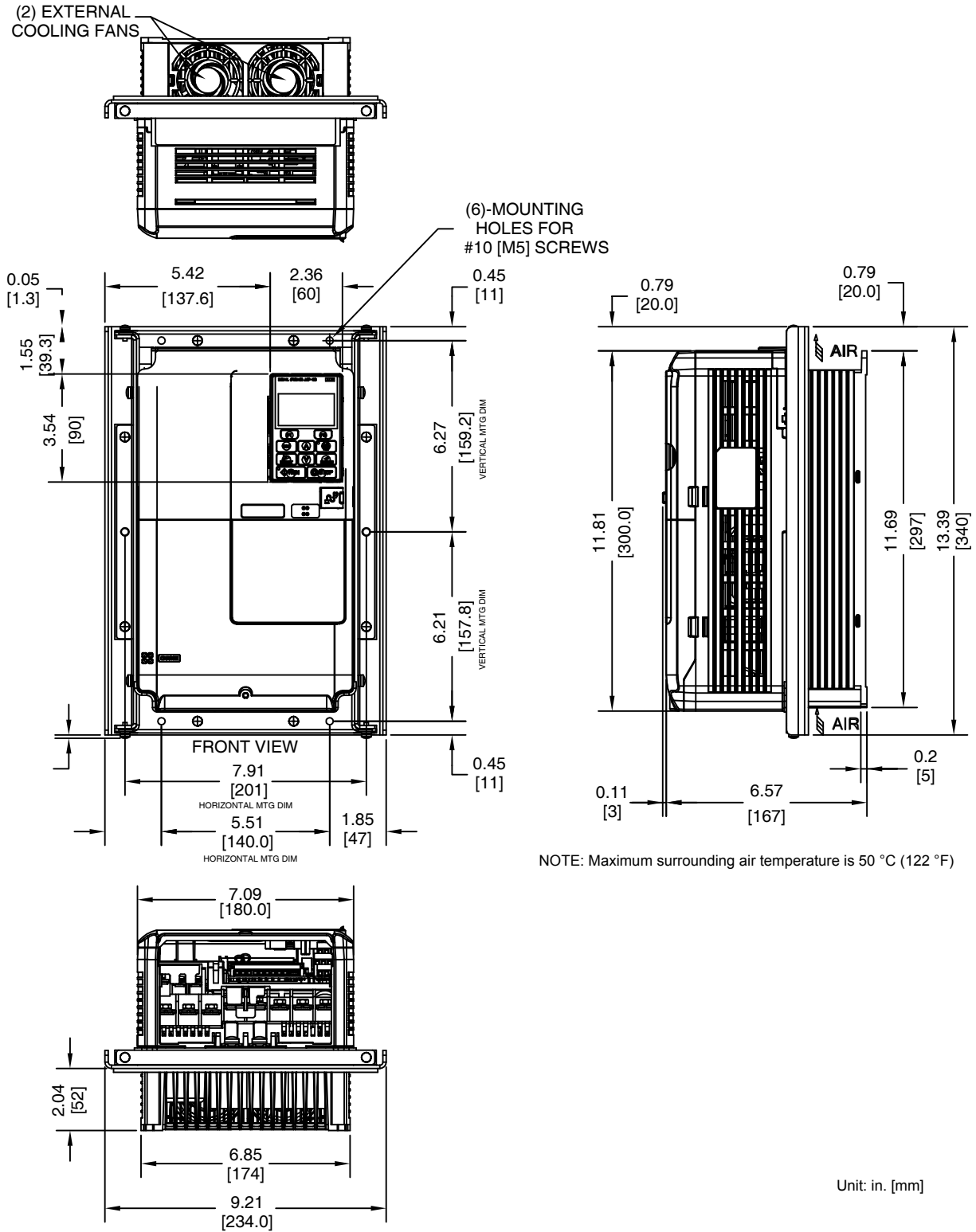

Figure 2.21 Model 4A0031

■ Flange Type Heat Loss Data

Table 2.15 Model 4A0031

Drive Model	Voltage Class	Heat Loss (W)						Wt. kg (lb)
		ND (Fc = 2 kHz)			HD (Fc = 8 kHz)			
		Internal	External	Total	Internal	External	Total	
4A0031	400	160.5	294.6	455.1	115.1	208.0	323.1	5.7 (12.5)

■ Flange Type Panel Cutout Dimensions for External Heatsink Mounting

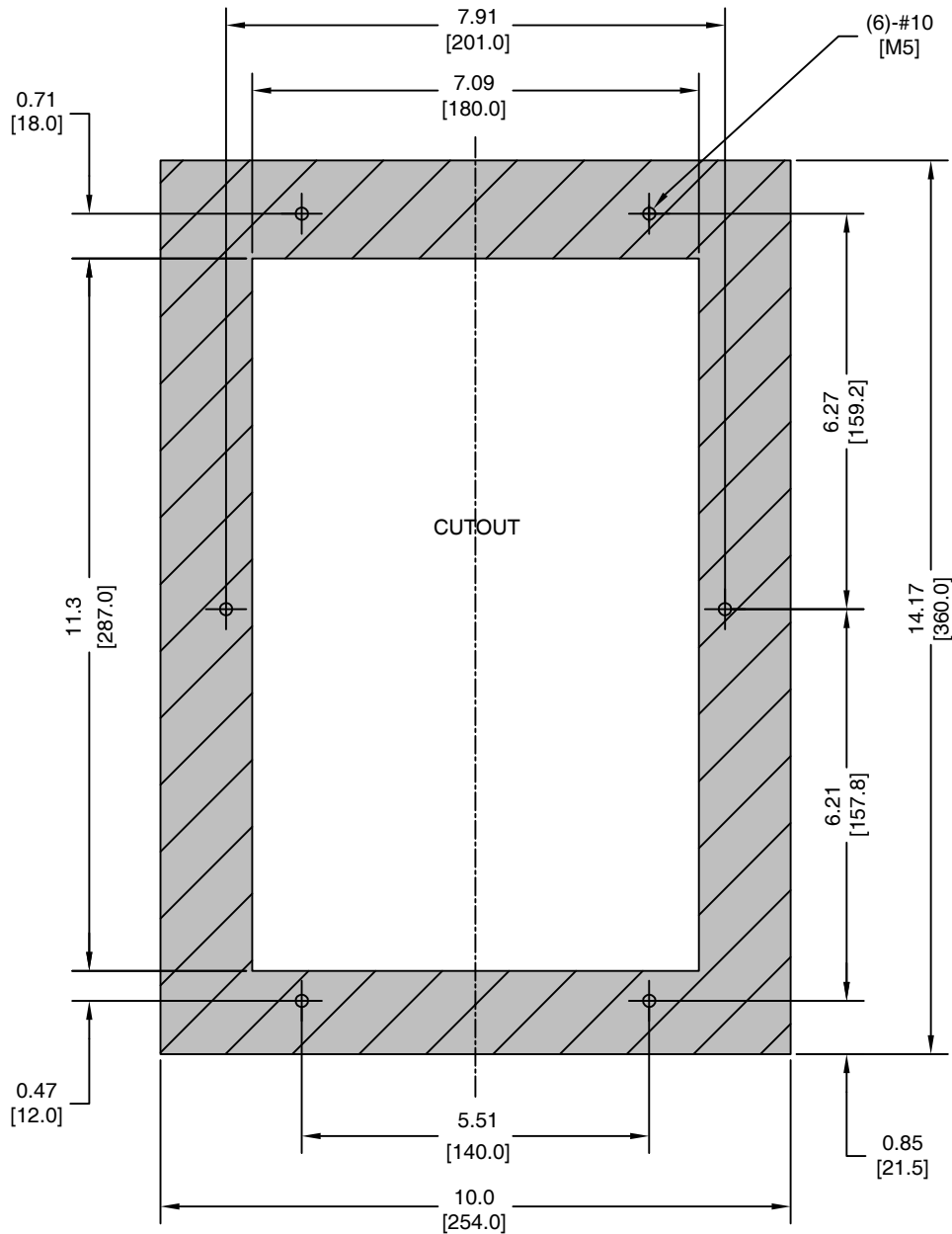

NOTES:

1. CUTOUT TOLERANCES:  
+/- 0.02 in. [0.5 mm]
2. EXPOSED HEATSINK  
RECOMMENDED CLEARANCE  
D=1.97 in. [50 mm] MINUS PANEL THICKNESS

Unit: in. [mm]

Figure 2.22 Model 4A0031

◆ Flange Type Models 2A0056, 4A0038, and 5A0017 and 5A0022

■ Flange Type Exterior and Mounting Dimensions

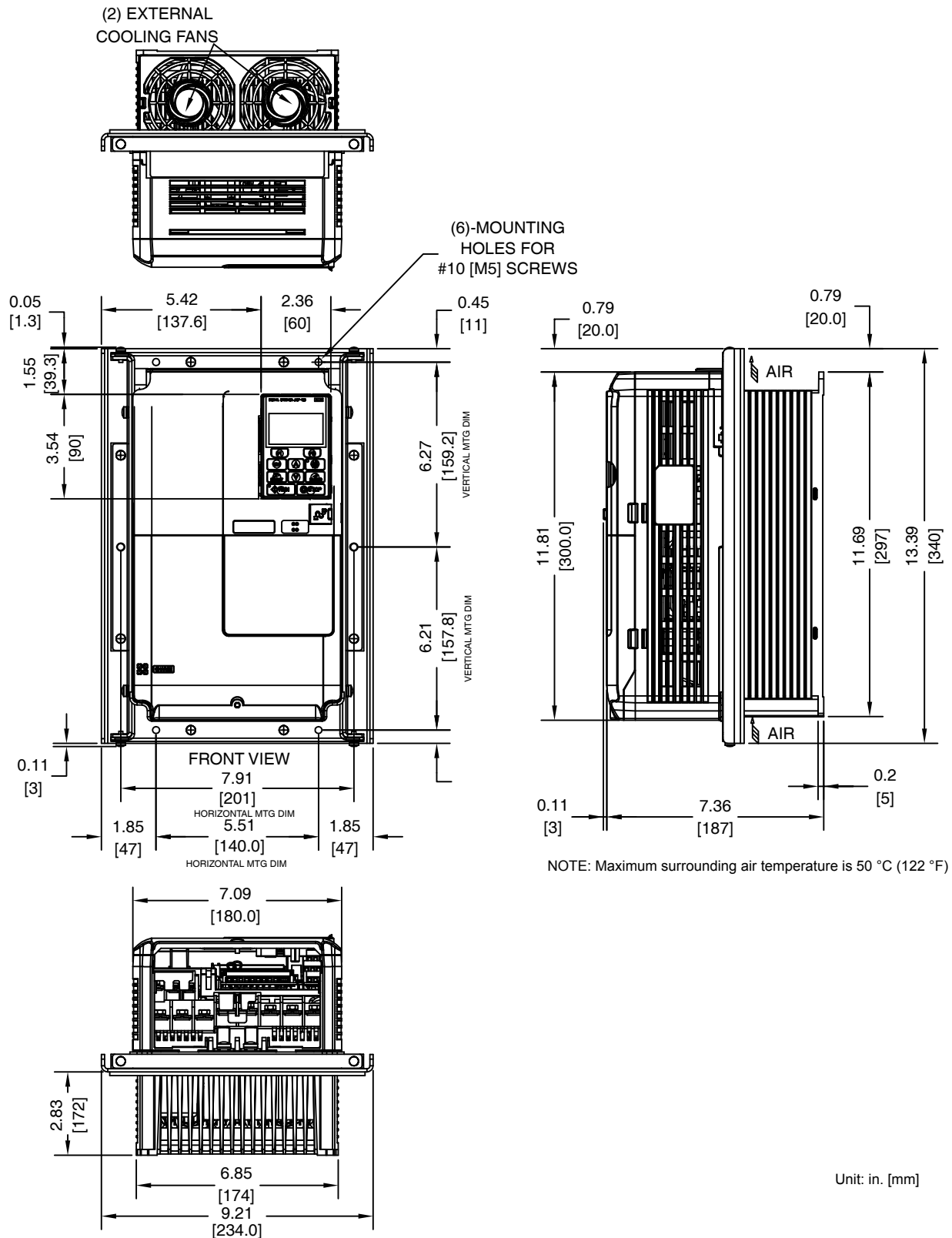

Figure 2.23 Models 2A0056, 4A0038, and 5A0017 and 5A0022



■ Flange Type Heat Loss Data

Table 2.16 Models 2A0056, 4A0038, and 5A0017 and 5A0022

Drive Model	Voltage Class	Heat Loss (W)						Wt. kg (lb)
		ND (Fc = 2 kHz)			HD (Fc = 8 kHz)			
		Internal	External	Total	Internal	External	Total	
2A0056	200	175.4	370.7	546.1	129.9	280.2	410.1	5.9 (13.0)

  

Drive Model	Voltage Class	Heat Loss (W)						Wt. kg (lb)
		ND (Fc = 2 kHz)			HD (Fc = 8 kHz)			
		Internal	External	Total	Internal	External	Total	
4A0038	400	181.6	339.6	521.2	140.8	262.6	403.4	6.0 (13.2)

Drive Model	Voltage Class	Heat Loss (W)						Wt. kg (lb)
		ND (Fc = 2 kHz)			HD (Fc = 8 kHz)			
		Internal	External	Total	Internal	External	Total	
5A0017	600	146.7	96.6	243.3	67.5	144.7	212.2	6.0 (13.2)
5A0022		178.3	99.4	277.7	81.1	203.8	284.9	6.0 (13.2)

■ Flange Type Panel Cutout Dimensions for External Heatsink Mounting

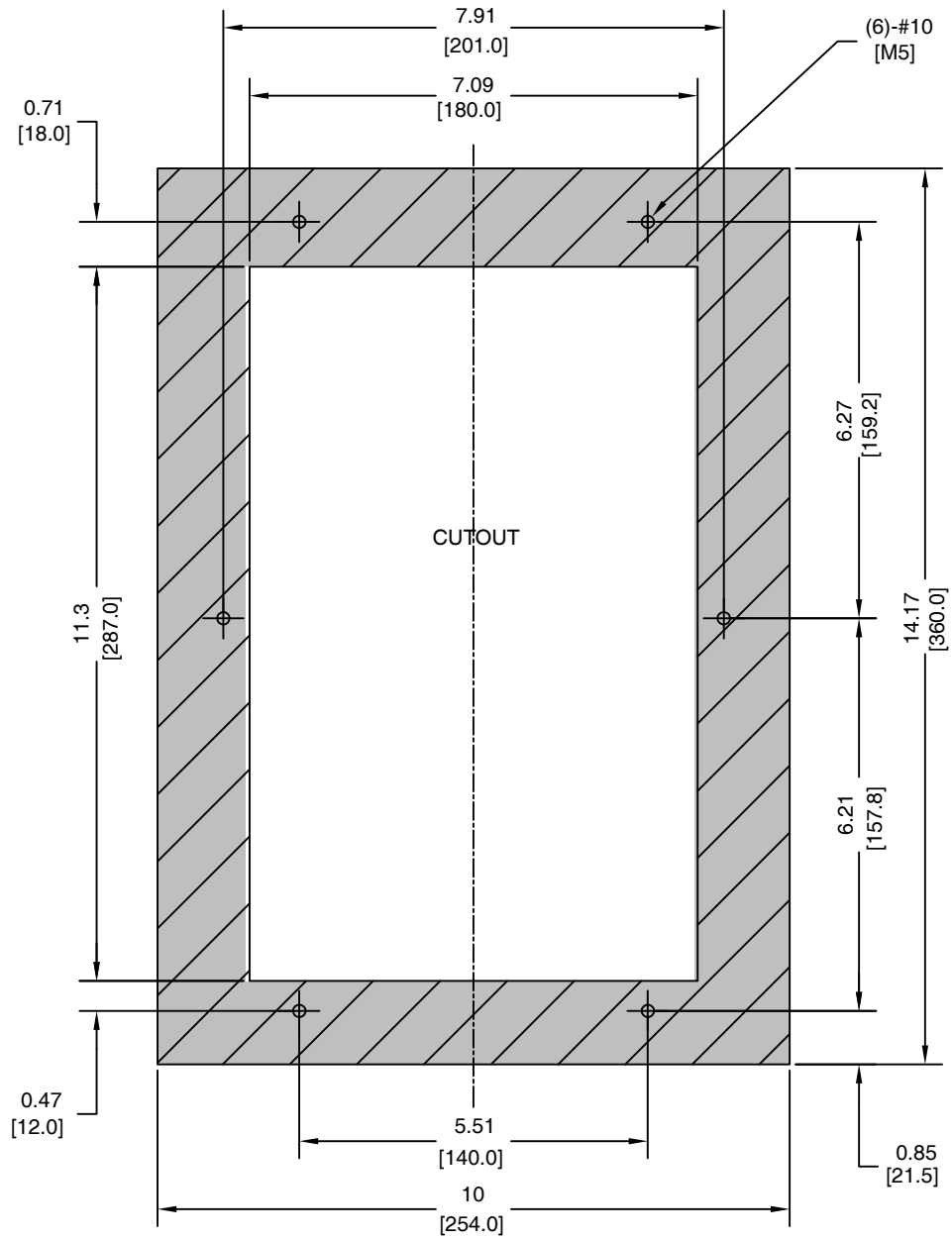

NOTES:

1. CUTOUT TOLERANCES:  
+/- 0.021 in. [0.5 mm]
2. EXPOSED HEATSINK  
RECOMMENDED CLEARANCE  
D=3.5 in. [88.9 mm] MINUS PANEL THICKNESS

Unit: in. [mm]

Figure 2.24 Models 2A0056, 4A0038, and 5A0017 and 5A0022

◆ Flange Type Models 2A0069 and 2A0081, 4A0044, and 5A0027 and 5A0032

■ Flange Type Exterior and Mounting Dimensions

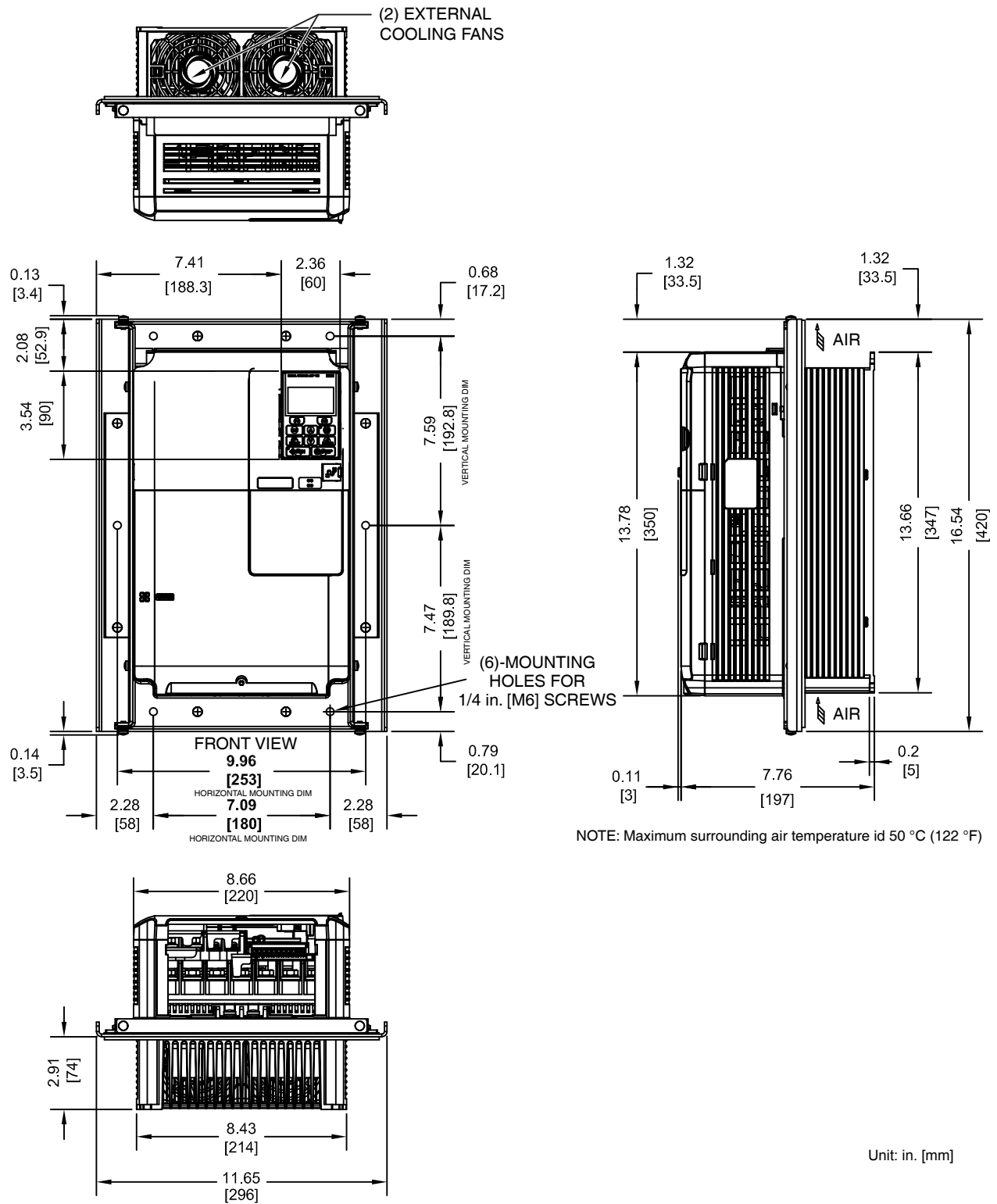

Figure 2.25 Models 2A0069 and 2A0081, 4A0044, and 5A0027 and 5A0032

## 2.2 Flange Type Enclosure (NEMA 12 Backside) Dimensions & Heat Loss

### ■ Flange Type Heat Loss Data

Table 2.17 Models 2A0069 and 2A0081, 4A0044, and 5A0027 and 5A0032

Drive Model	Voltage Class	Heat Loss (W)						Wt. kg (lb)
		ND (Fc = 2 kHz)			HD (Fc = 8 kHz)			
		Internal	External	Total	Internal	External	Total	
2A0069	200	204.5	491.3	695.8	162.8	394.9	557.7	9.1 (20.0)
2A0081		257.4	527.4	784.8	220.9	459.8	680.7	10.0 (22.0)

Drive Model	Voltage Class	Heat Loss (W)						Wt. kg (lb)
		ND (Fc = 2 kHz)			HD (Fc = 8 kHz)			
		Internal	External	Total	Internal	External	Total	
4A0044	400	208.9	389.6	598.5	179.4	329.8	509.2	8.7 (19.1)

Drive Model	Voltage Class	Heat Loss (W)						Wt. kg (lb)
		ND (Fc = 2 kHz)			HD (Fc = 8 kHz)			
		Internal	External	Total	Internal	External	Total	
5A0027	600	227.2	132.1	359.3	113.9	267.2	381.1	8.7 (19.1)
5A0032		279.9	141.6	421.5	132.2	332.9	465.1	8.7 (19.1)

■ Flange Type Panel Cutout Dimensions for External Heatsink Mounting

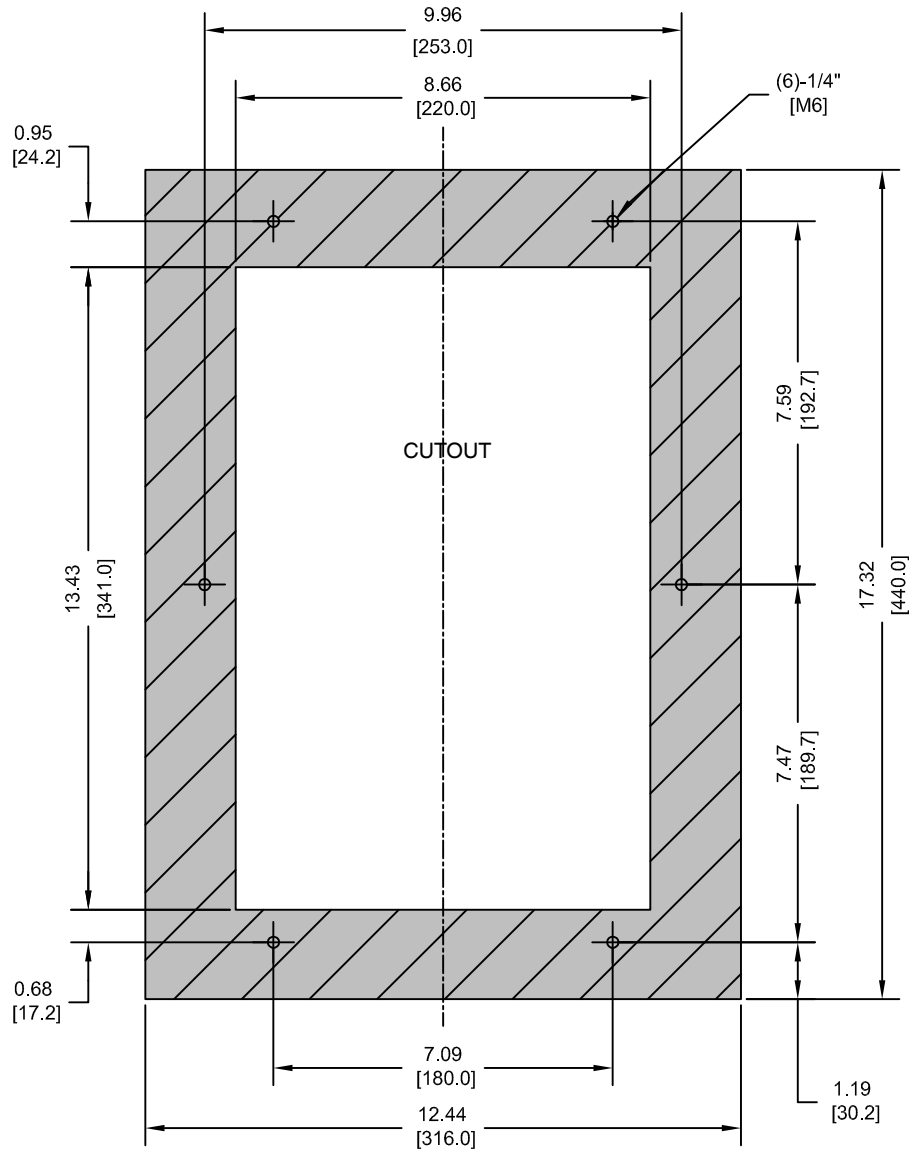

NOTES:

1. CUTOUT TOLERANCES:

+/- 0.02 in. [0.5 mm]

2. EXPOSED HEATSINK

RECOMMENDED CLEARANCE

D=3.35 in. [85 mm] MINUS PANEL THICKNESS

Unit: in. [mm]

Figure 2.26 Models 2A0069 and 2A0081, 4A0044, and 5A0027 and 5A0032

## 2.2 Flange Type Enclosure (NEMA 12 Backside) Dimensions & Heat Loss

### ◆ Flange Type Models 2A0110 and 4A0058

#### ■ Flange Type Exterior and Mounting Dimensions

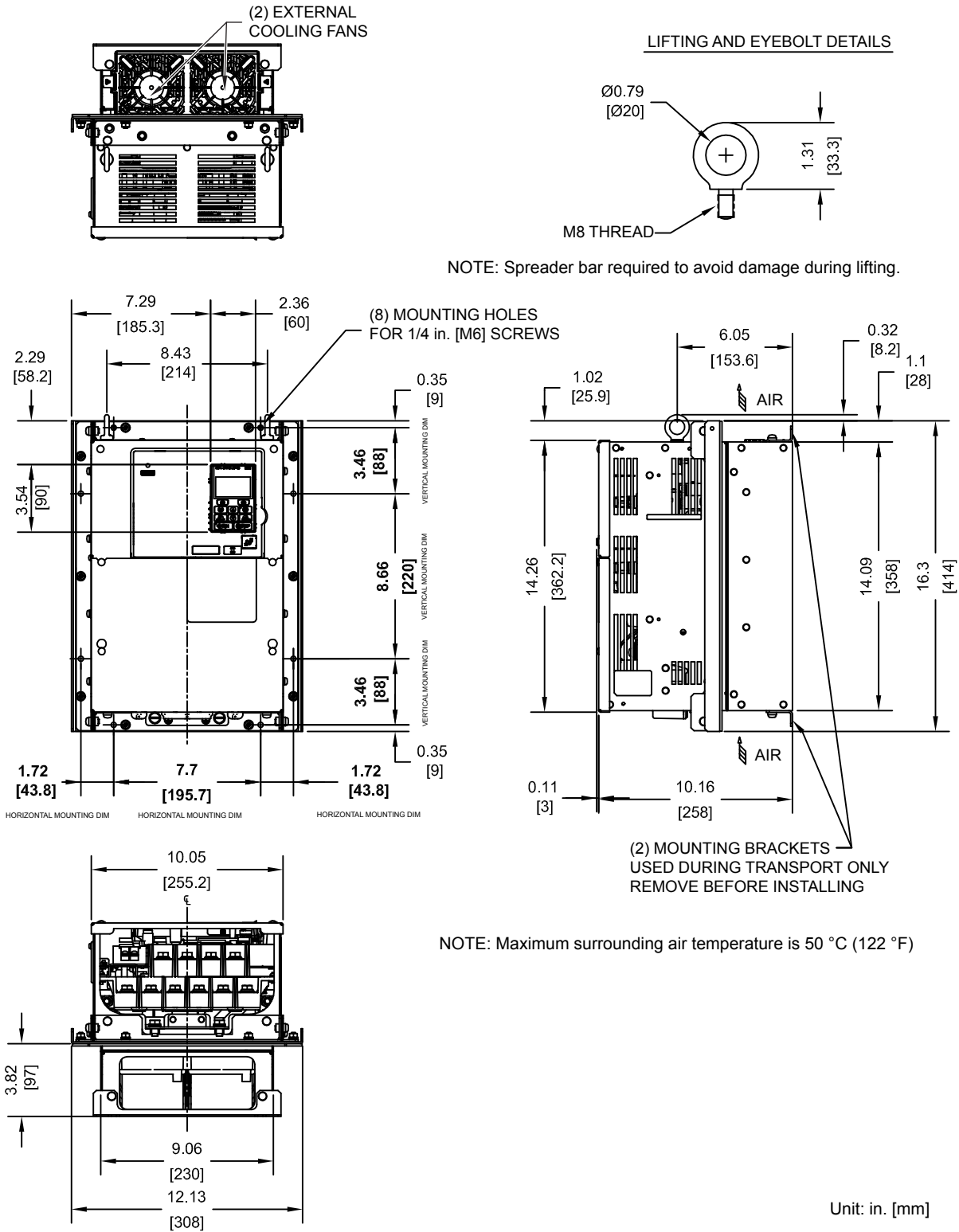

Figure 2.27 Models 2A0110 and 4A0058

■ Flange Type Heat Loss Data

Table 2.18 Models 2A0110 and 4A0058

Drive Model	Voltage Class	Heat Loss (W)						Wt. kg (lb)
		ND (Fc = 2 kHz)			HD (Fc = 8 kHz)			
		Internal	External	Total	Internal	External	Total	
2A0110	200	286	719	1005	211	510	721	23 (50.6)

Drive Model	Voltage Class	Input Type	Heat Loss (W)						Wt. kg (lb)
			ND (Fc = 2 kHz)			HD (Fc = 8 kHz)			
			Internal	External	Total	Internal	External	Total	
4A0058	400	6-Pulse	215	471	686	170	349	519	23 (50.6)

■ Flange Type Panel Cutout Dimensions for External Heatsink Mounting

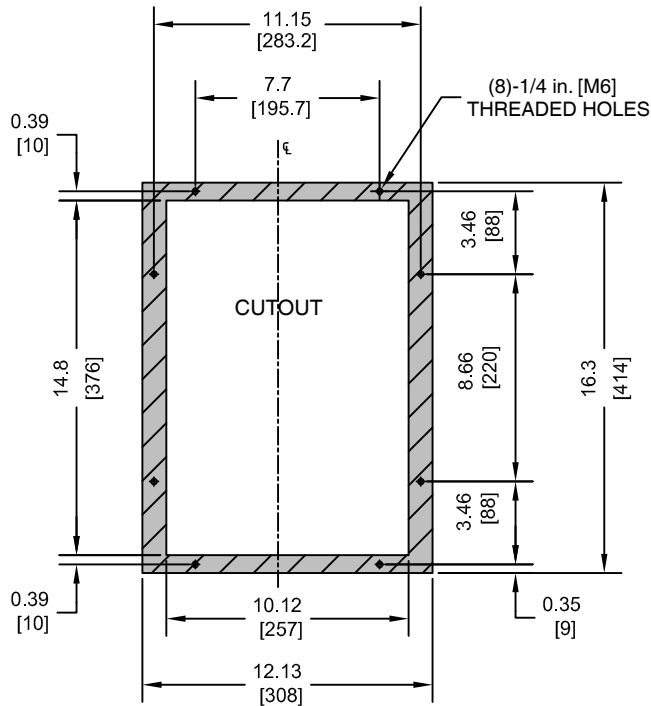

NOTES:

- CUTOUT TOLERANCES:  
+/- 0.02 in. [0.5 mm]
  - EXPOSED HEATSINK DEPTH  
D=3.82 in. [97 mm] MINUS PANEL THICKNESS
  - MINIMUM RECOMMENDED PANEL THICKNESS: 12 GA
- Unit: in. [mm]

Figure 2.28 Models 2A0110 and 4A0058

◆ Flange Type Models 2A0138, 4A0072, and 5A0041 and 5A0052

■ Flange Type Exterior and Mounting Dimensions

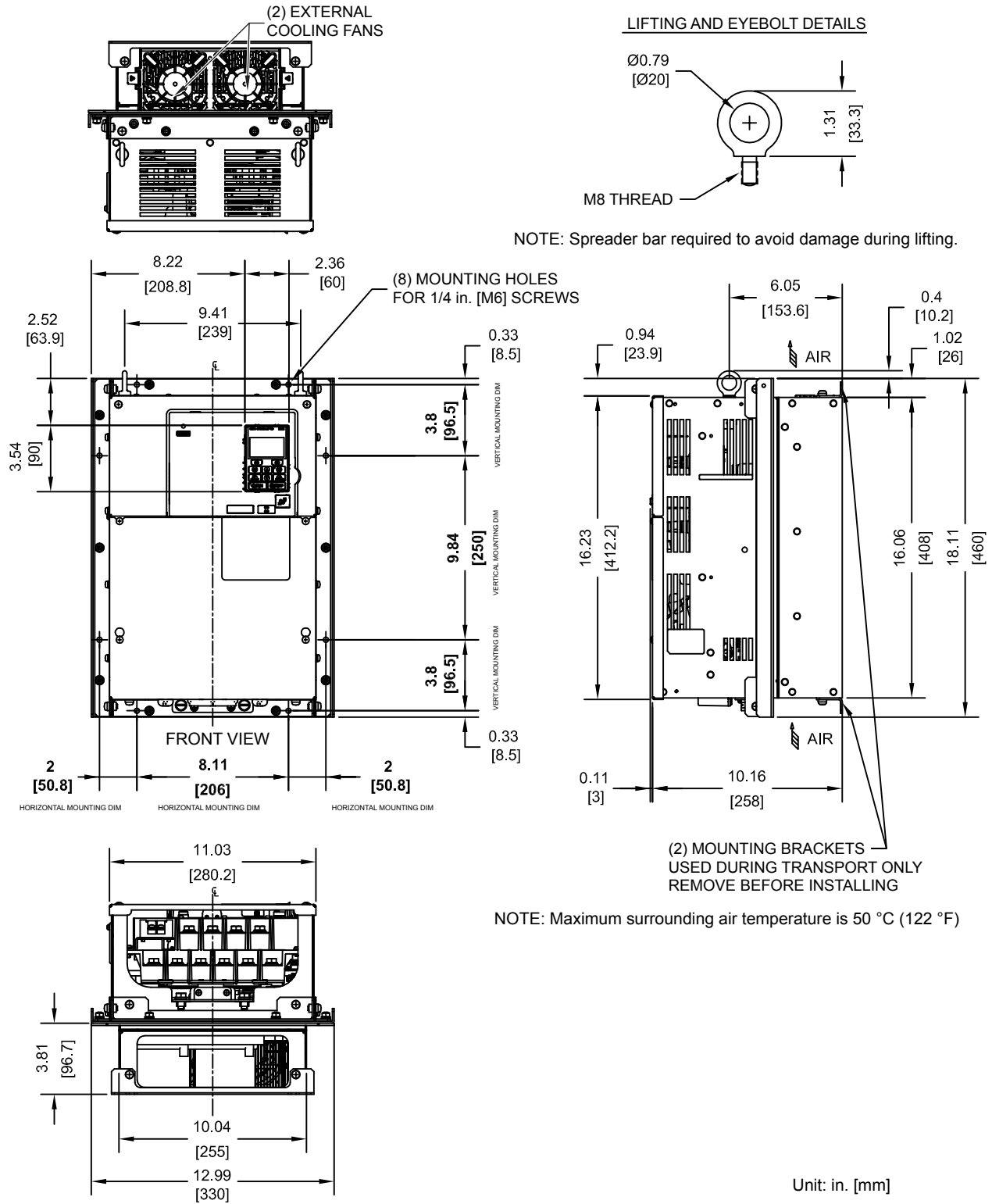

Figure 2.29 Models 2A0138, 4A0072, and 5A0041 and 5A0052



■ Flange Type Heat Loss Data

Table 2.19 Models 2A0138, 4A0072, and 5A0041 and 5A0052

Drive Model	Voltage Class	Heat Loss (W)						Wt. kg (lb)
		ND (Fc = 2 kHz)			HD (Fc = 8 kHz)			
		Internal	External	Total	Internal	External	Total	
2A0138	200	312	842	1154	250	662	912	28 (61.6)

  

Drive Model	Voltage Class	Input Type	Heat Loss (W)						Wt. kg (lb)
			ND (Fc = 2 kHz)			HD (Fc = 8 kHz)			
			Internal	External	Total	Internal	External	Total	
4A0072	400	6-Pulse	265	605	870	217	484	701	27 (59.4)

Drive Model	Voltage Class	Heat Loss (W)						Wt. kg (lb)
		ND (Fc = 2 kHz)			HD (Fc = 8 kHz)			
		Internal	External	Total	Internal	External	Total	
5A0041	600	136	331	467	128	406	534	27 (59.4)
5A0052		166	428	594	161	527	688	27 (59.4)

■ Flange Type Panel Cutout Dimensions for External Heatsink Mounting

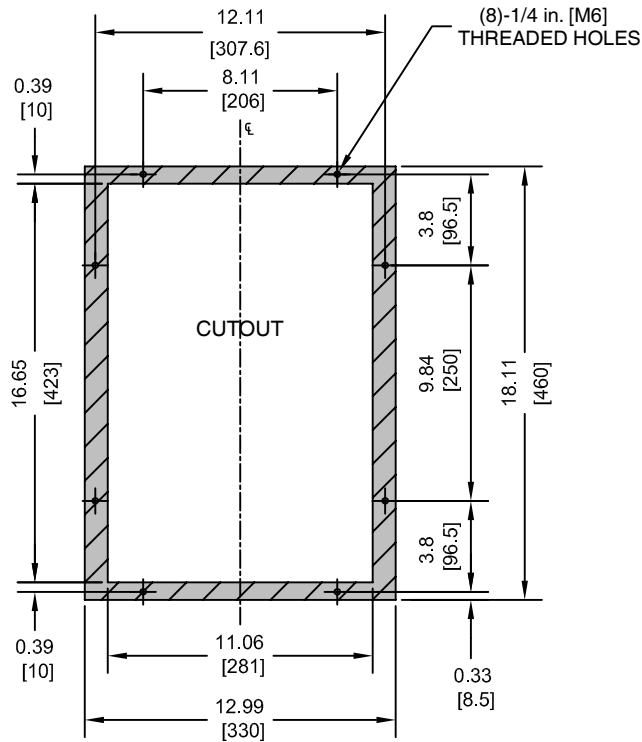

NOTES:

1. CUTOUT TOLERANCES:  
+/- 0.02 in. [0.5 mm]
2. EXPOSED HEATSINK DEPTH  
D=3.81 in. [97 mm] MINUS PANEL THICKNESS
3. MINIMUM RECOMMENDED PANEL  
THICKNESS: 12 GA

Unit: in. [mm]

Figure 2.30 Models 2A0138, 4A0072, and 5A0041 and 5A0052

## 2.2 Flange Type Enclosure (NEMA 12 Backside) Dimensions & Heat Loss

### ◆ Flange Type Models 4A0088 and 4A0103

#### ■ Flange Type Exterior and Mounting Dimensions

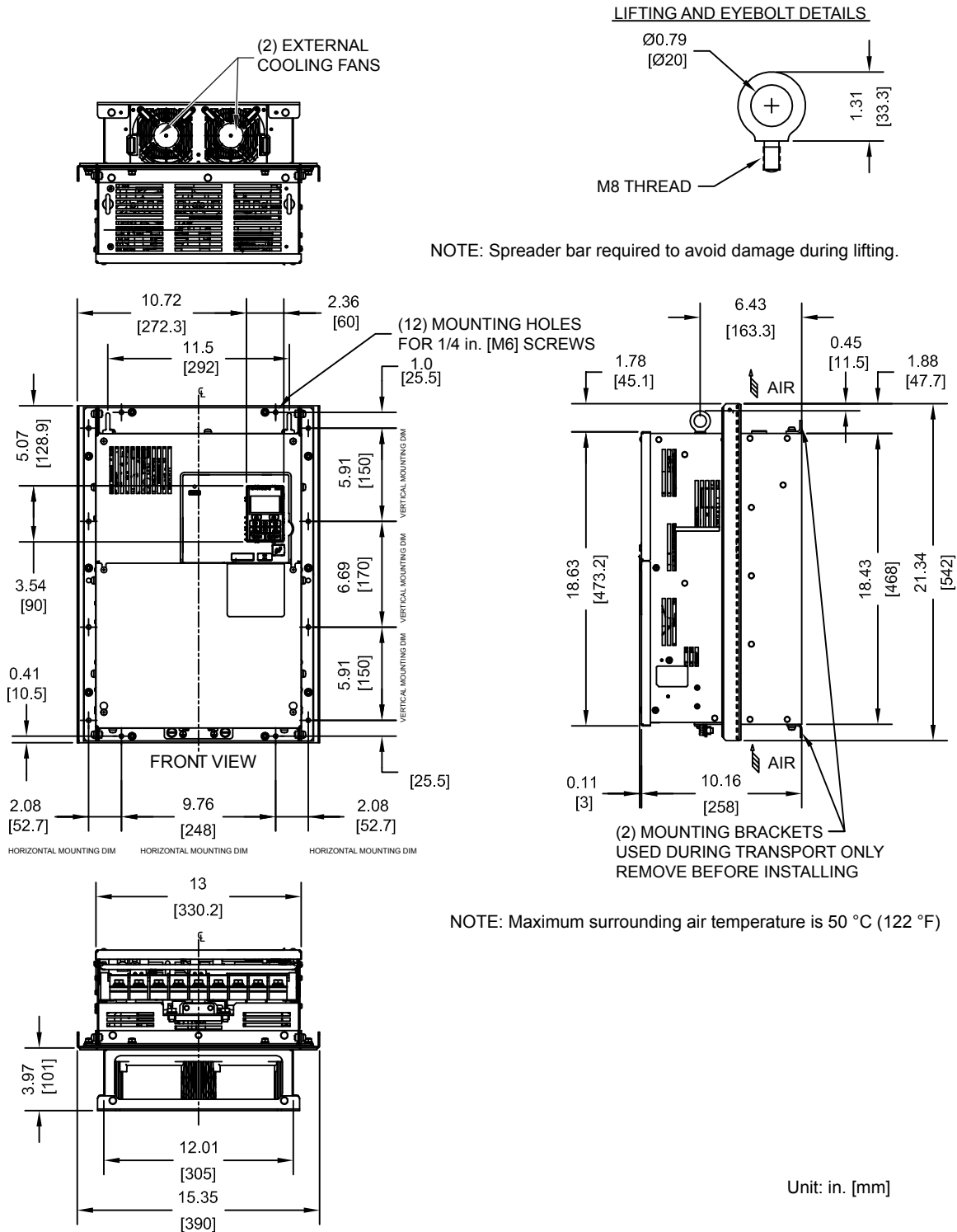

Figure 2.31 Models 4A0088 and 4A0103

■ Flange Type Heat Loss Data

Table 2.20 Models 4A0088 and 4A0103

Drive Model	Voltage Class	Input Type	Heat Loss (W)						Wt. kg (lb)
			ND (Fc = 2 kHz)			HD (Fc = 8 kHz)			
			Internal	External	Total	Internal	External	Total	
4A0088	400	6-Pulse	308	684	992	254	563	817	39 (85.8)
4A0103			357	848	1205	299	723	1022	

■ Flange Type Panel Cutout Dimensions for External Heatsink Mounting

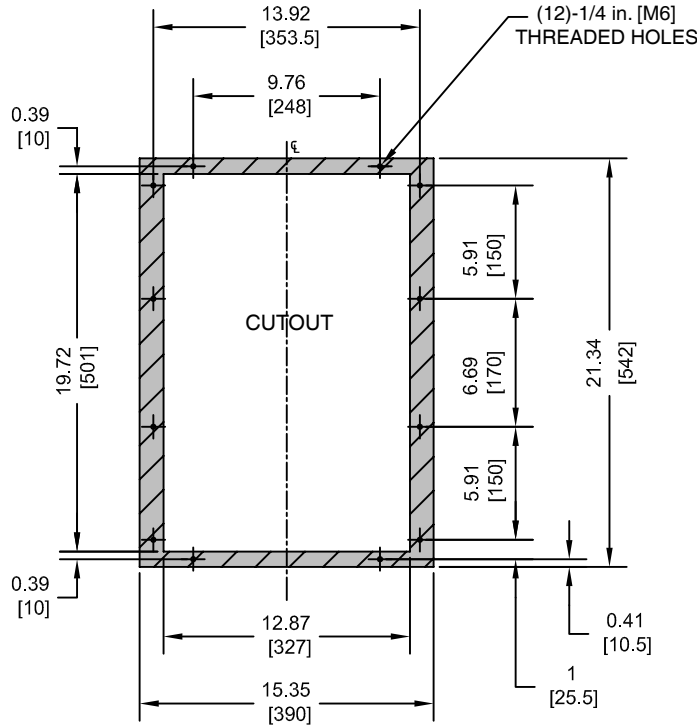

NOTES:

- CUTOUT TOLERANCES:  
+/- 0.02 in. [0.5 mm]
  - EXPOSED HEATSINK DEPTH  
D=3.97 in. [101 mm] MINUS PANEL THICKNESS
  - MINIMUM RECOMMENDED PANEL THICKNESS: 12 GA
- Unit: in. [mm]

Figure 2.32 Models 4A0088 and 4A0103

## 2.2 Flange Type Enclosure (NEMA 12 Backside) Dimensions & Heat Loss

### ◆ Flange Type Models 2A0169 and 2A0211, 4A0139 and 4A0165, and 5A0062 to 5A0099

#### ■ Flange Type Exterior and Mounting Dimensions

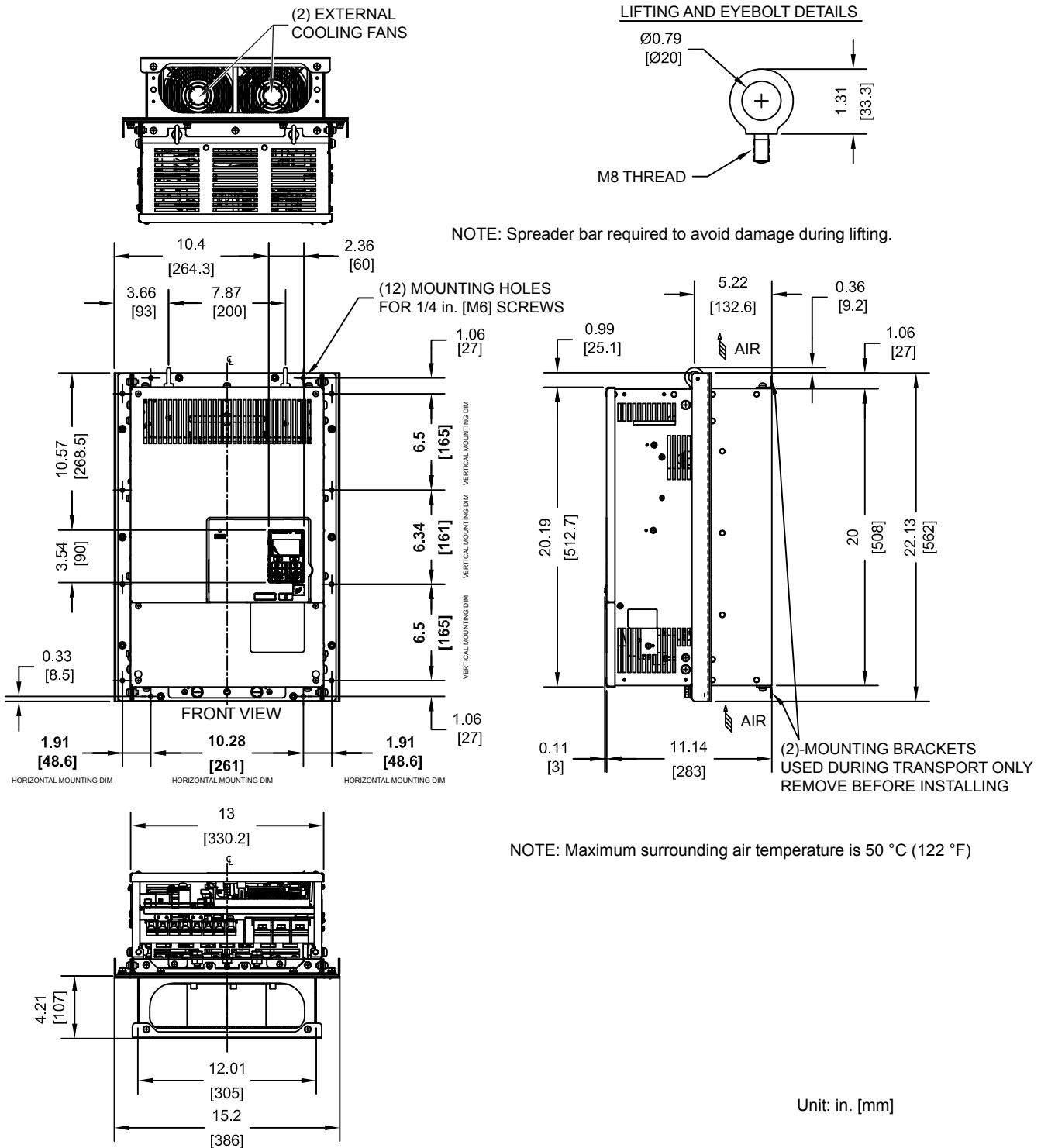

Figure 2.33 Models 2A0169 and 2A0211, 4A0139 and 4A0165, and 5A0062 to 5A0099

■ Flange Type Heat Loss Data

Table 2.21 Models 2A0169 and 2A0211, 4A0139 and 4A0165, and 5A0062 to 5A0099

Drive Model	Voltage Class	Heat Loss (W)						Wt. kg (lb)
		ND (Fc = 2 kHz)			HD (Fc = <f> )			
		Internal	External	Total	Internal	External	Total	
2A0169	200	380	1014	1394	306	816	1122	41 (90.2)
2A0211		473	1218	1691	378	976	1354	42 (92.4)

<1> Carrier frequency is set to 8 kHz in model 2A0169 and set to 5 kHz in model 2A0211.

Drive Model	Voltage Class	Input Type	Heat Loss (W)						Wt. kg (lb)
			ND (Fc = 2 kHz)			HD (Fc = <f> )			
			Internal	External	Total	Internal	External	Total	
4A0139	400	6-Pulse	534	1215	1749	416	908	1324	45 (99.0)
4A0165			668	1557	2225	580	1340	1920	46 (101.2)

<1> Carrier frequency is set to 8 kHz in model 4A0139 and set to 5 kHz in model 4A0165.

Drive Model	Voltage Class	Heat Loss (W)						Wt. kg (lb)
		ND (Fc = 2 kHz)			HD (Fc = <f> )			
		Internal	External	Total	Internal	External	Total	
5A0062	600	279	791	1070	335	1272	1607	45 (99.0)
5A0077		329	959	1288	379	1457	1836	45 (99.0)
5A0099		412	1253	1665	352	1267	1619	45 (99.0)

<1> Carrier frequency is set to 8 kHz in models 5A0062 and 5A0077 and set to 5 kHz in model 5A0099.

■ Flange Type Panel Cutout Dimensions for External Heatsink Mounting

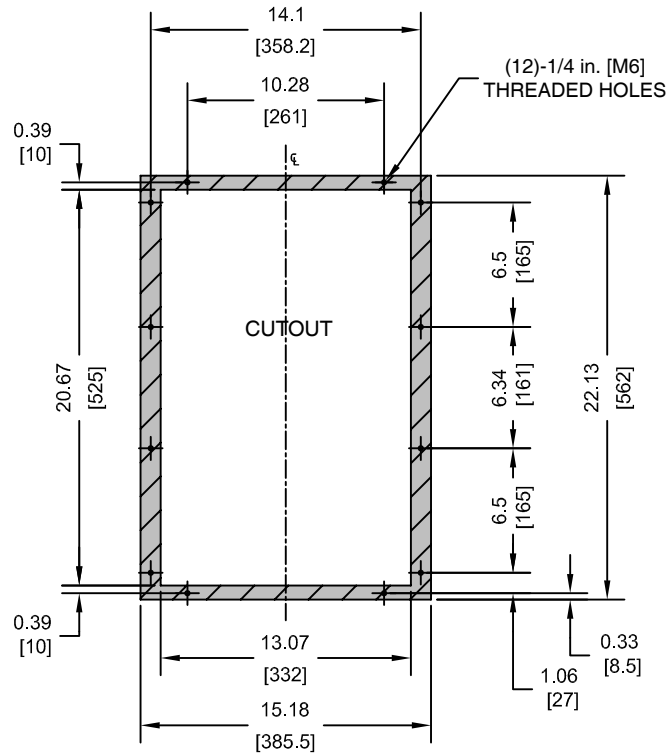

- NOTES:
- CUTOUT TOLERANCES:  
+/- 0.02 in. [0.5 mm]
  - EXPOSED HEATSINK DEPTH  
D=4.21 in. [107 mm] MINUS PANEL THICKNESS
  - MINIMUM RECOMMENDED PANEL THICKNESS: 12 GA
- Unit: in. [mm]

Figure 2.34 Models 2A0169 and 2A0211, 4A0139 and 4A0165, and 5A0062 to 5A0099

◆ Flange Type Models 2A0250 and 2A0312, 4A0208, and 5A0125 and 5A0145

■ Flange Type Exterior and Mounting Dimensions

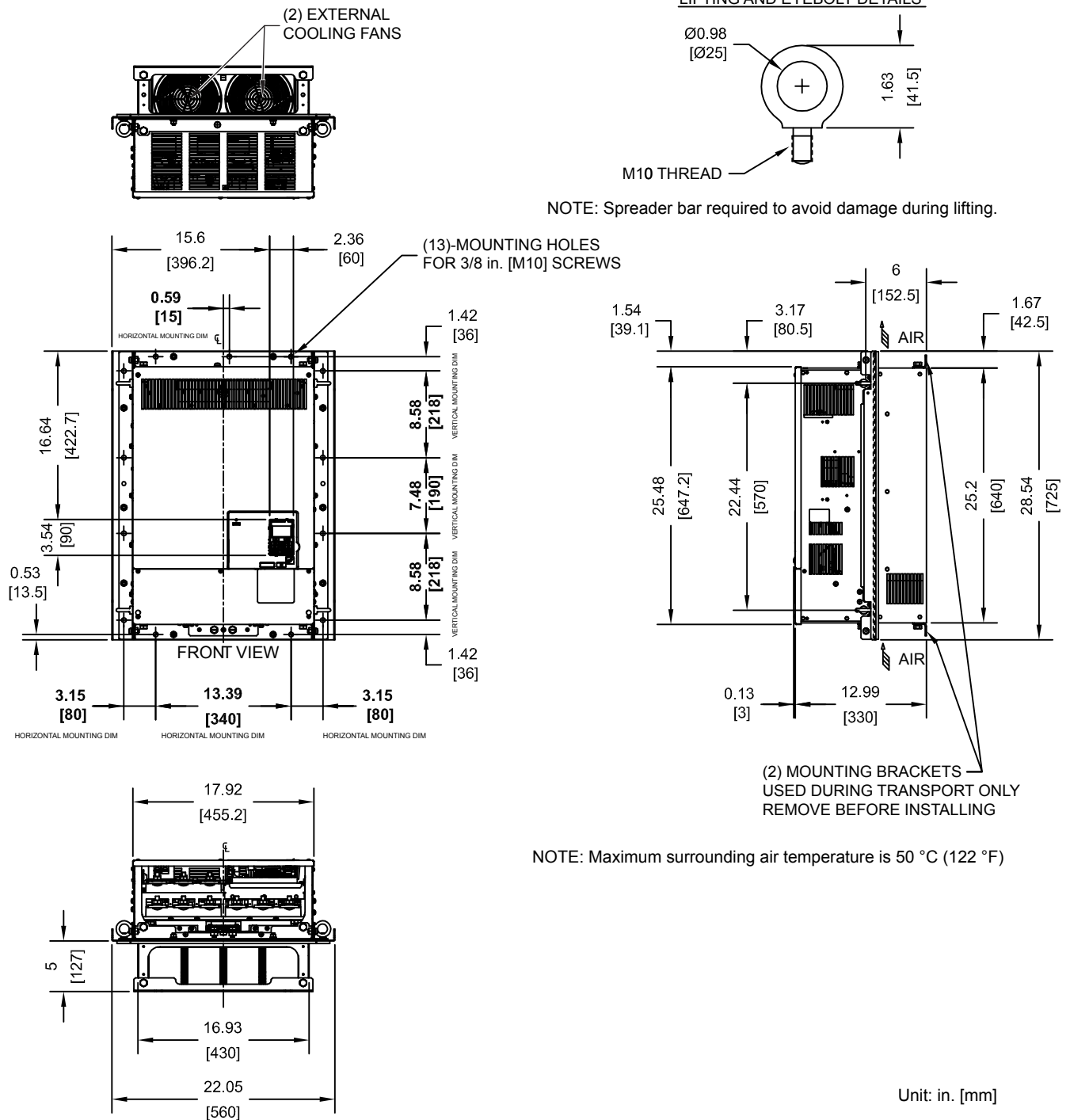

Figure 2.35 Models 2A0250 and 2A0312, 4A0208, and 5A0125 and 5A0145

## 2.2 Flange Type Enclosure (NEMA 12 Backside) Dimensions & Heat Loss

### ■ Flange Type Heat Loss Data

Table 2.22 Models 2A0250 and 2A0312, 4A0208, and 5A0125 and 5A0145

Drive Model	Voltage Class	Heat Loss (W)						Wt. kg (lb)
		ND (Fc = 2 kHz)			HD (Fc = 5 kHz)			
		Internal	External	Total	Internal	External	Total	
2A0250	200	594	1764	2358	466	1514	1980	83 (183)
2A0312		665	2020	2685	588	1936	2524	88 (194)

Drive Model	Voltage Class	Input Type	Heat Loss (W)						Wt. kg (lb)
			ND (Fc = 2 kHz)			HD (Fc = 5 kHz)			
			Internal	External	Total	Internal	External	Total	
4A0208	400	6-Pulse	607	1800	2407	541	1771	2312	87 (191)

Drive Model	Voltage Class	Heat Loss (W)						Wt. kg (lb)
		ND (Fc = 2 kHz)			HD (Fc = 2 kHz)			
		Internal	External	Total	Internal	External	Total	
5A0125	600	537	1641	2178	422	1328	1750	87 (191)
5A0145		603	1860	2463	508	1638	2146	87 (191)

### ■ Flange Type Panel Cutout Dimensions for External Heatsink Mounting

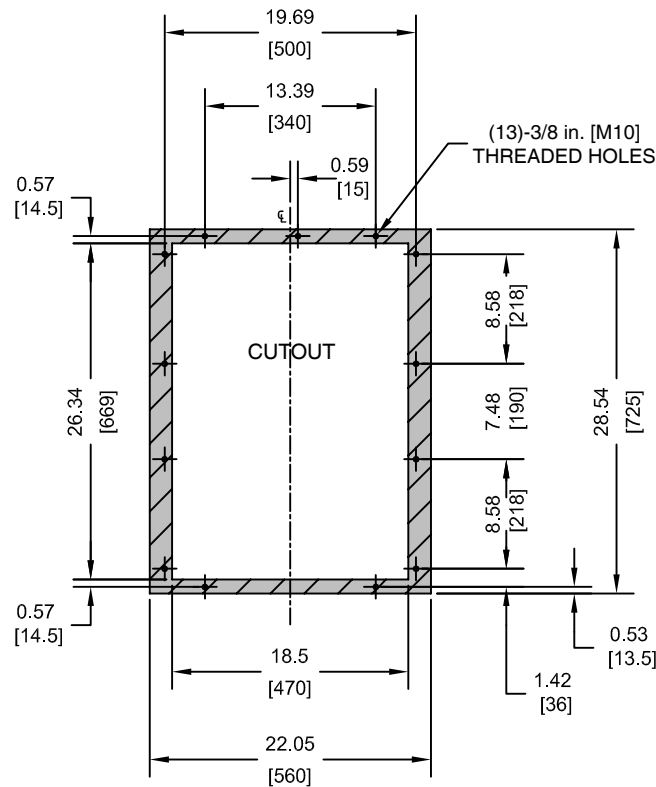

**NOTES:**

1. CUTOUT TOLERANCES:  
+/- 0.02 in. [0.5 mm]
  2. EXPOSED HEATSINK DEPTH  
D=5.00 in. [127 mm] MINUS PANEL THICKNESS
  3. MINIMUM RECOMMENDED PANEL  
THICKNESS: 10 GA
- Unit: in. [mm]

Figure 2.36 Models 2A0250 and 2A0312, 4A0208, and 5A0125 and 5A0145



◆ Flange Type Models 2A0360 and 2A0415, 4A0250 to 4A0362, and 5A0192 and 5A0242  
 ■ Flange Type Exterior and Mounting Dimensions

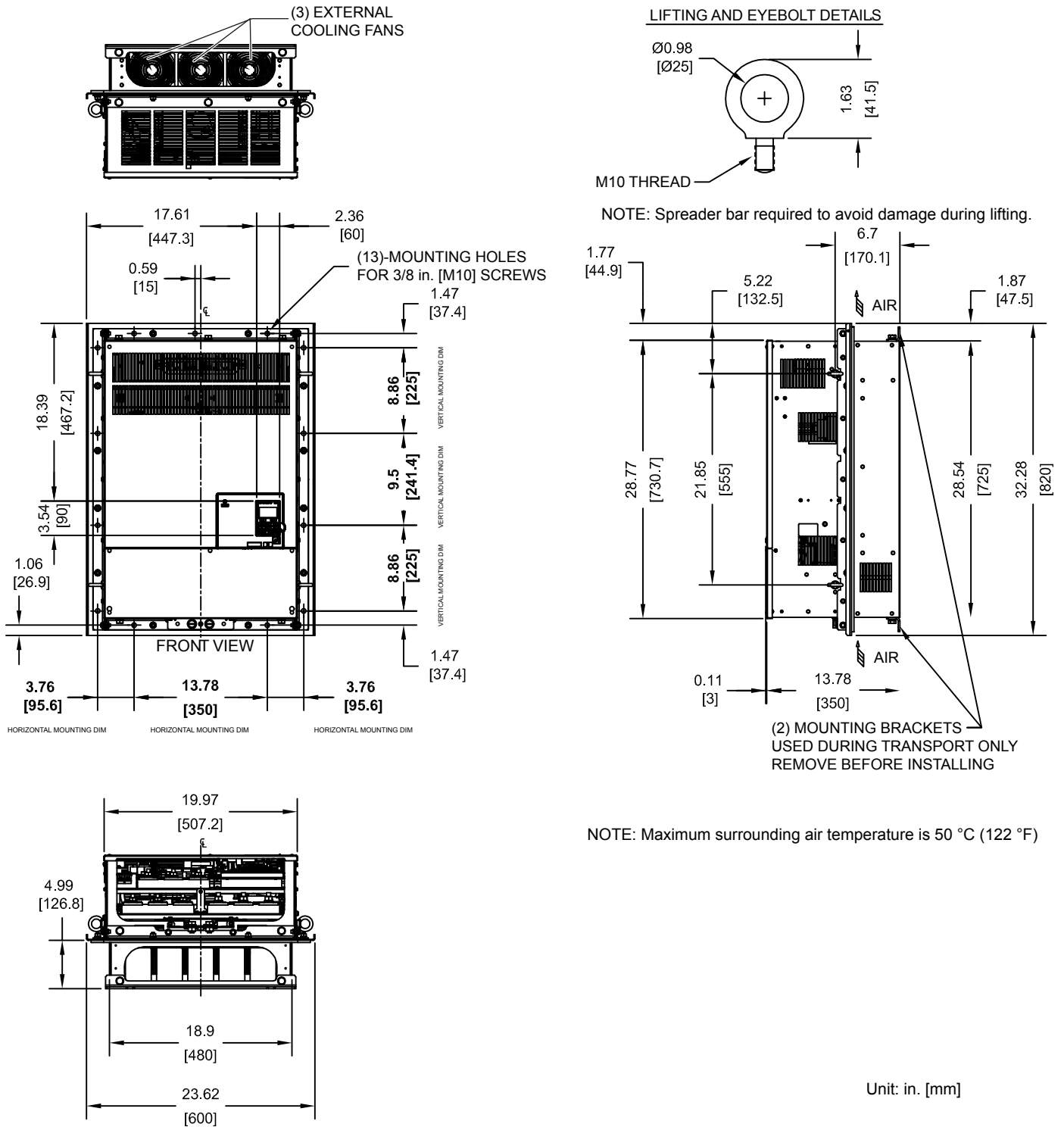

Figure 2.37 Models 2A0360 and 2A0415, 4A0250 to 4A0362, and 5A0192 and 5A0242

## 2.2 Flange Type Enclosure (NEMA 12 Backside) Dimensions & Heat Loss

### ■ Flange Type Heat Loss Data

Table 2.23 Models 2A0360 and 2A0415, 4A0250 to 4A0362, and 5A0192 and 5A0242

Drive Model	Voltage Class	Heat Loss (W)						Wt. kg (lb)
		ND (Fc = 2 kHz)			HD (Fc = <1> )			
		Internal	External	Total	Internal	External	Total	
2A0360	200	894	2698	3592	783	2564	3347	108 (238)
2A0415		954	2672	3626	954	2672	3626	–

<1> Carrier frequency is set to 5 kHz in model 2A0360 and set to 2 kHz in model 2A0415.

Drive Model	Voltage Class	Input Type	Heat Loss (W)						Wt. kg (lb)
			ND (Fc = 2 kHz)			HD (Fc = <1> )			
			Internal	External	Total	Internal	External	Total	
4A0250	400	6-Pulse	803	2379	3182	715	2360	3075	106 (233)
4A0296			905	2448	3353	787	2391	3178	112 (246)
4A0362			1130	3168	4298	985	3075	4060	117 (257)

<1> Carrier frequency is set to 5 kHz in models 4A0250 and 4A0296, and set to 2 kHz in model 4A0362.

Drive Model	Voltage Class	Heat Loss (W)						Wt. kg (lb)
		ND (Fc = 2 kHz)			HD (Fc = 2 kHz)			
		Internal	External	Total	Internal	External	Total	
5A0192	600	769	2420	3189	648	2114	2762	117 (257)
5A0242		1131	3100	4231	896	2526	3422	117 (257)

■ Flange Type Panel Cutout Dimensions for External Heatsink Mounting

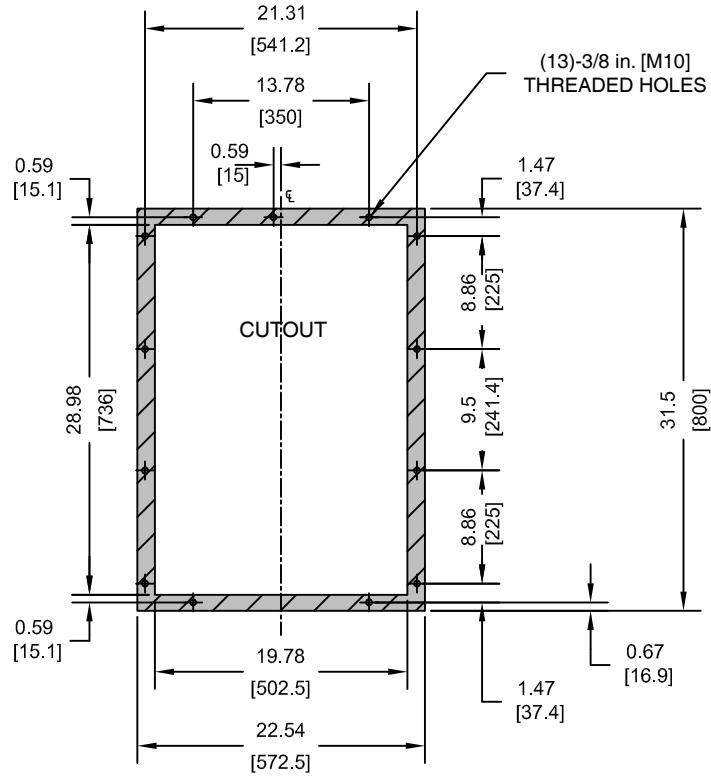

NOTES:

1. CUTOUT TOLERANCES:  
+/- 0.02 in. [0.5 mm]
2. EXPOSED HEATSINK DEPTH  
D=4.99 in. [127 mm] MINUS PANEL THICKNESS
3. MINIMUM RECOMMENDED PANEL  
THICKNESS: 10 GA

Unit: in. [mm]

Figure 2.38 Models 2A0360 and 2A0415, 4A0250 to 4A0362, and 5A0192 and 5A0242

## 2.2 Flange Type Enclosure (NEMA 12 Backside) Dimensions & Heat Loss

### ◆ Flange Type Model 4A0414

#### ■ Flange Type Exterior and Mounting Dimensions

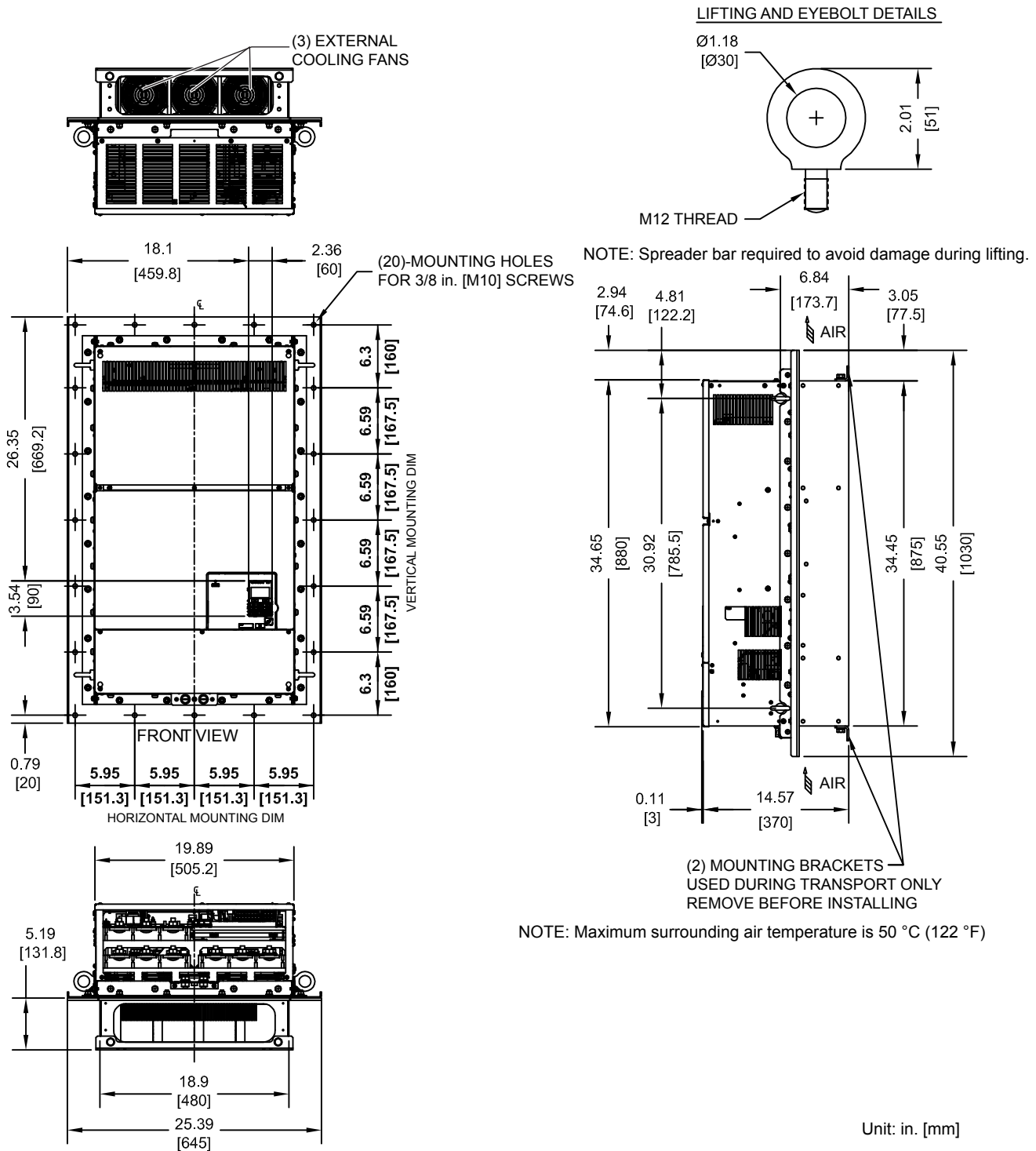

Figure 2.39 Model 4A0414

■ Flange Type Heat Loss Data

Table 2.24 Model 4A0414

Drive Model	Voltage Class	Heat Loss (W)						Wt. kg (lb)
		ND (Fc = 2 kHz)			HD (Fc = 8 kHz)			
		Internal	External	Total	Internal	External	Total	
4A0414	400	1295	3443	4738	1164	3578	4742	138 (304)

■ Flange Type Panel Cutout Dimensions for External Heatsink Mounting

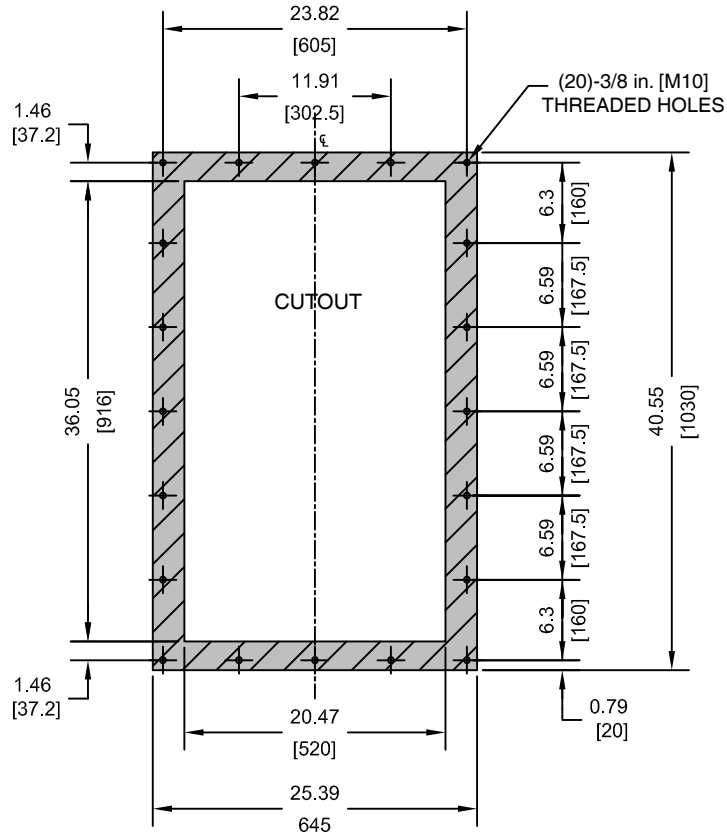

- NOTES:
- CUTOUT TOLERANCES:  
+/- 0.02 in. [0.5 mm]
  - EXPOSED HEATSINK DEPTH  
D=5.19 in. [132 mm] MINUS PANEL THICKNESS
  - MINIMUM RECOMMENDED PANEL THICKNESS: 10 GA
- Unit: in. [mm]

Figure 2.40 Model 4A0414

◆ Flange Type Models 4A0515 and 4A0675

■ Flange Type Exterior and Mounting Dimensions

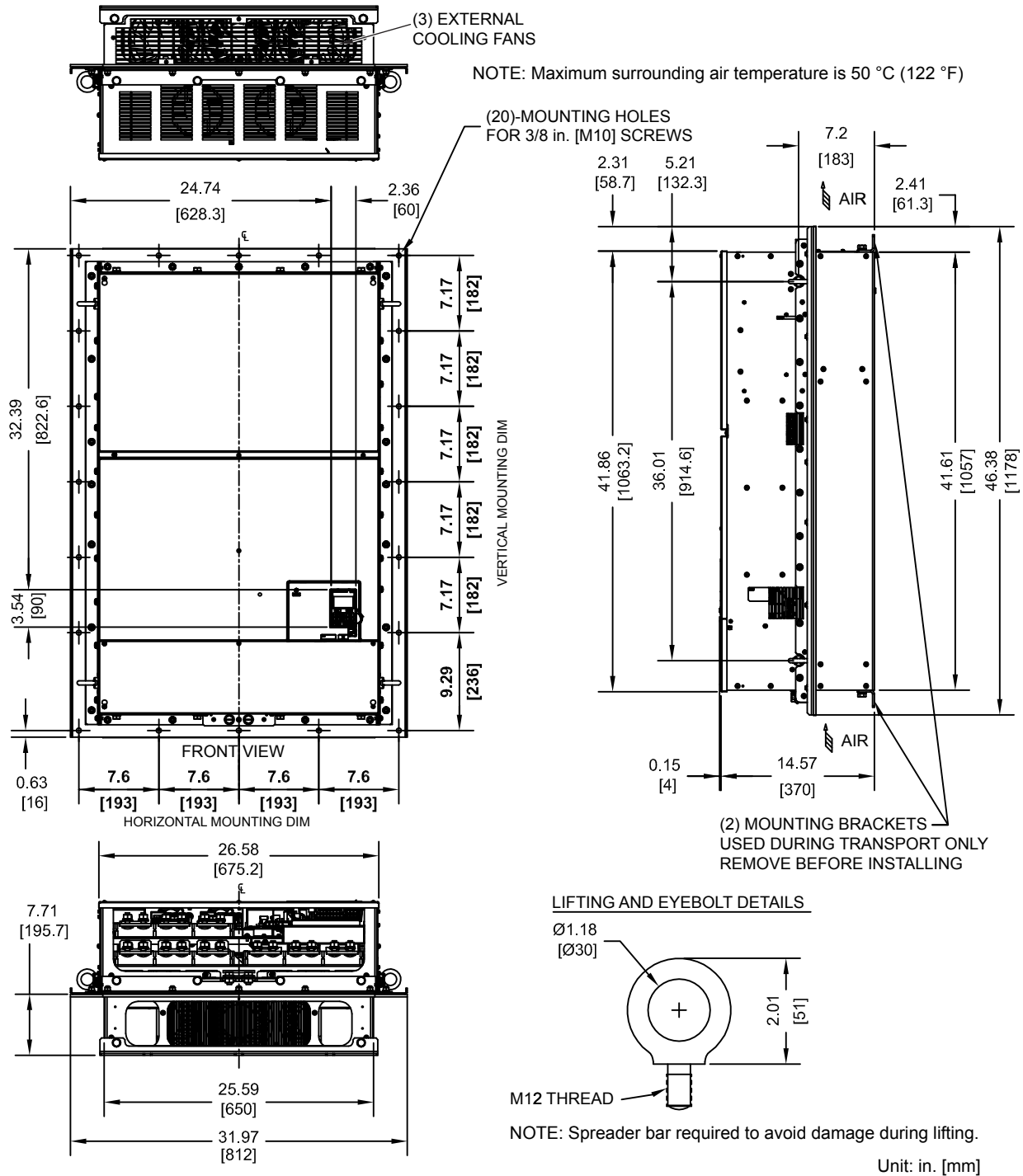

Figure 2.41 Models 4A0515 and 4A0675

■ Flange Type Heat Loss Data

Table 2.25 Models 4A0515 and 4A0675

Drive Model	Voltage Class	Heat Loss (W)						Wt. kg (lb)
		ND (Fc = 2 kHz)			HD (Fc = 8 kHz)			
		Internal	External	Total	Internal	External	Total	
4A0515	400	1668	4850	6518	1386	3972	5358	223 (492)
4A0675		2037	4861	6898	1685	4191	5876	228 (503)

■ Flange Type Panel Cutout Dimensions for External Heatsink Mounting

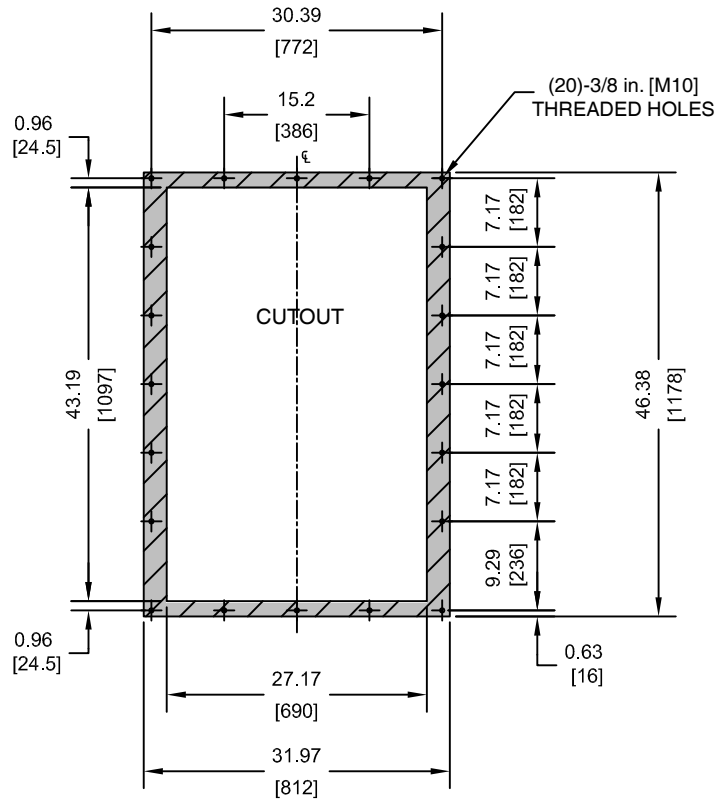

NOTES:

1. CUTOUT TOLERANCES:  
+/- 0.02 in. [0.5 mm]
  2. EXPOSED HEATSINK DEPTH  
D=7.71 in. [196 mm] MINUS PANEL THICKNESS
  3. MINIMUM RECOMMENDED PANEL  
THICKNESS: 10 GA
- Unit: in. [mm]

Figure 2.42 Models 4A0515 and 4A0675

◆ Flange Type Models 4A0930 and 4A1200

■ Flange Type Exterior and Mounting Dimensions

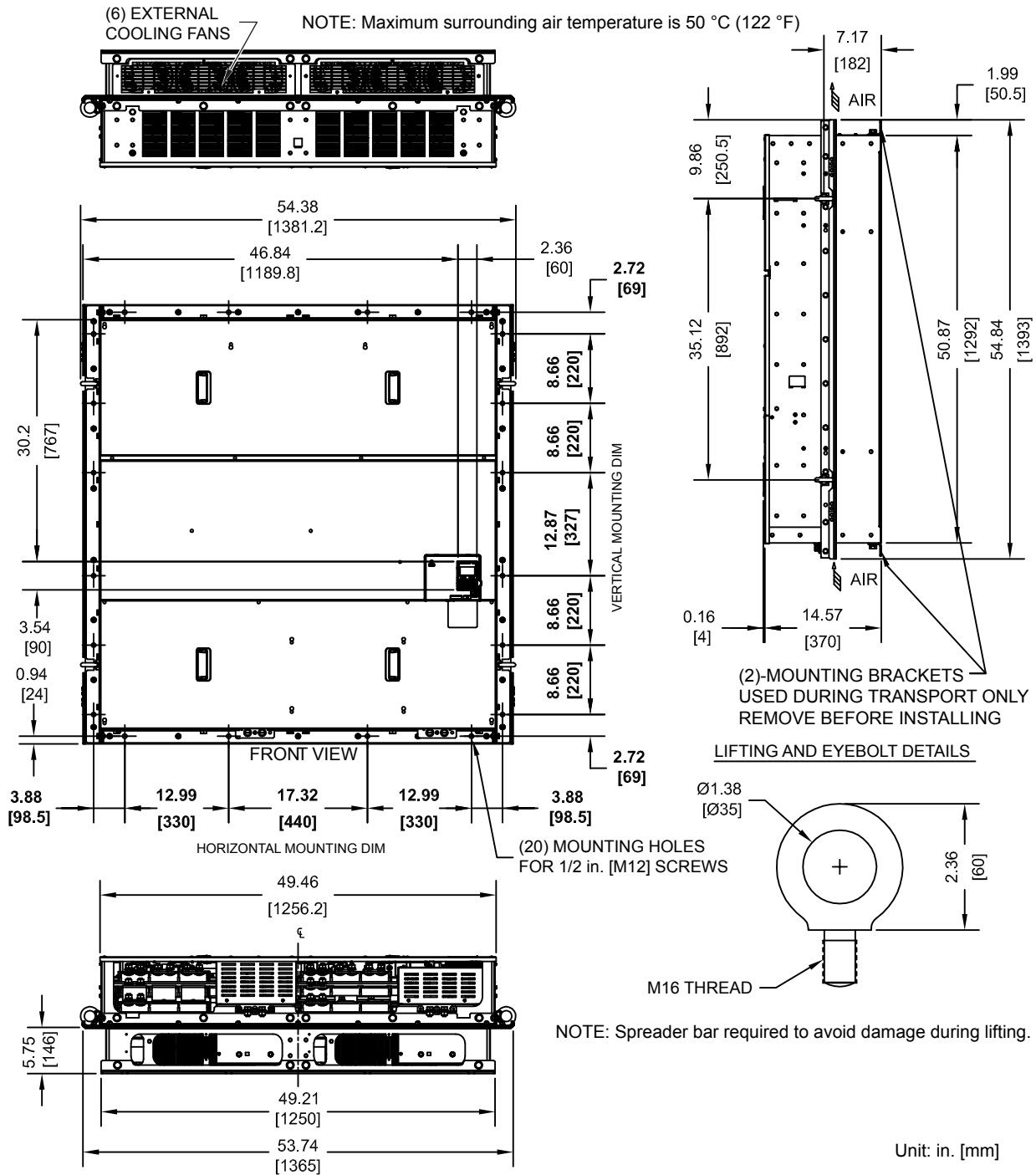

Figure 2.43 Models 4A0930 and 4A1200

■ Flange Type Heat Loss Data

Table 2.26 Models 4A0930 and 4A1200

Drive Model	Voltage Class	Heat Loss (W)						Wt. kg (lb)
		ND (Fc = 2 kHz)			HD (Fc = 8 kHz)			
		Internal	External	Total	Internal	External	Total	
4A0930	400	2952	8476	11428	2455	6912	9367	575 (1265)
4A1200		3612	8572	12184	3155	7626	10781	587 (1291)



■ Flange Type Panel Cutout Dimensions for External Heatsink Mounting

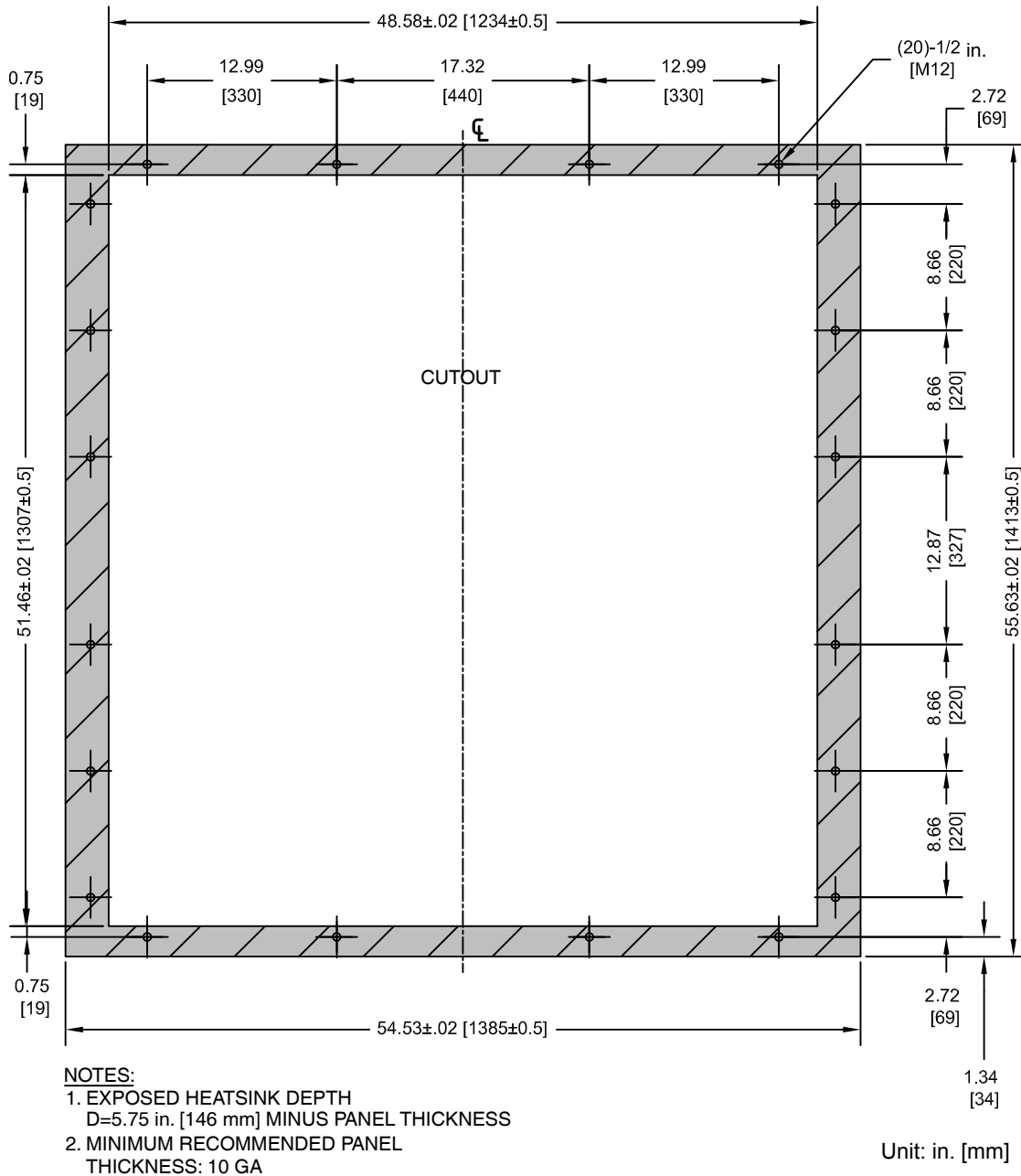

Figure 2.44 Models 4A0930 and 4A1200

**This Page Intentionally Blank**

# Electrical Installation

---

This chapter explains proper procedures for wiring the control circuit terminals, motor, and power supply.

<b>3.1</b>	<b>STANDARD CONNECTION DIAGRAM.....</b>	<b>92</b>
<b>3.2</b>	<b>MAIN CIRCUIT CONNECTION DIAGRAM.....</b>	<b>95</b>
<b>3.3</b>	<b>TERMINAL BLOCK CONFIGURATION.....</b>	<b>99</b>
<b>3.4</b>	<b>TERMINAL COVER.....</b>	<b>101</b>
<b>3.5</b>	<b>HOA KEYPAD AND FRONT COVER.....</b>	<b>103</b>
<b>3.6</b>	<b>TOP PROTECTIVE COVER.....</b>	<b>106</b>
<b>3.7</b>	<b>MAIN CIRCUIT WIRING.....</b>	<b>107</b>
<b>3.8</b>	<b>CONTROL CIRCUIT WIRING.....</b>	<b>120</b>
<b>3.9</b>	<b>CONTROL I/O CONNECTIONS.....</b>	<b>125</b>
<b>3.10</b>	<b>CONNECT TO A PC.....</b>	<b>130</b>

### 3.1 Standard Connection Diagram

Connect the drive and peripheral devices as shown in [Figure 3.1](#). It is possible to set and run the drive via the digital operator without connecting digital I/O wiring. This section does not discuss drive operation; [Refer to Start-Up Programming & Operation on page 131](#) for instructions on operating the drive.

**NOTICE:** *Inadequate wiring could result in damage to the drive. Install adequate branch circuit short circuit protection per applicable codes. The drive is suitable for circuits capable of delivering not more than 100,000 RMS symmetrical amperes, 240 Vac maximum (200 V class), 480 Vac maximum (400 V class), 600 Vac maximum (600 V class).*

**NOTICE:** *When the input voltage is 440 V or higher or the wiring distance is greater than 100 meters, pay special attention to the motor insulation voltage or use a drive duty motor. Failure to comply could lead to motor insulation breakdown.*

**NOTICE:** *Do not connect AC control circuit ground to drive enclosure. Improper drive grounding can cause control circuit malfunction.*

**Note:** The minimum load for the relay outputs M1-M2, M3-M4, MA-MB-MC, and MD-ME-MF is 10 mA.

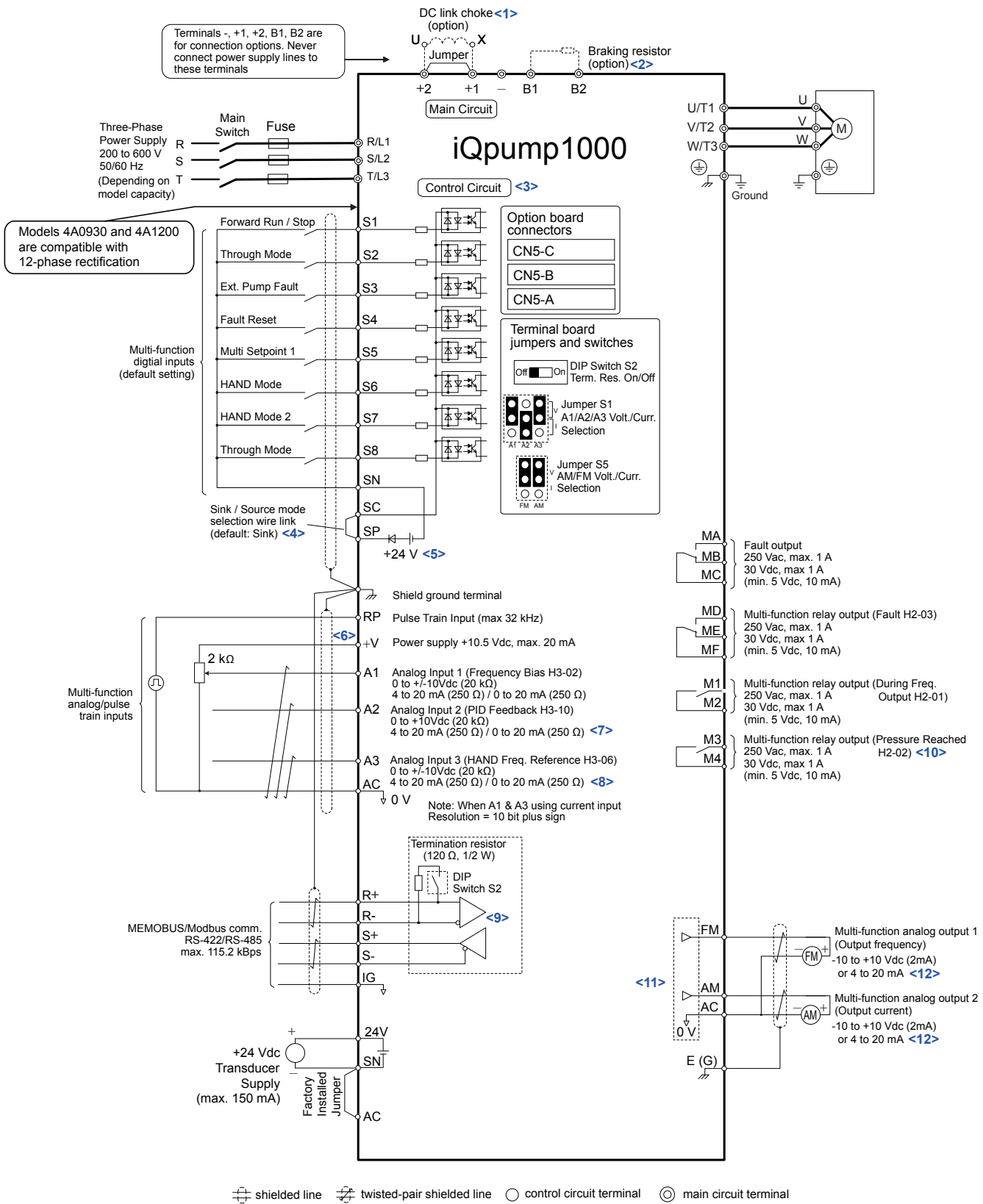

Figure 3.1 Drive Standard Connection Diagram (example: model 2A0040)

### 3.1 Standard Connection Diagram

---

- <1> Remove the jumper when installing a DC link choke. Models 2A0110 to 2A0415 and 4A0058 to 4A1200 come with a built-in DC link choke.
- <2> Set L8-55 to 0 to disable the protection function of the built-in braking transistor of the drive when using an optional regenerative converter or dynamic braking option. Leaving L8-55 enabled may cause a braking resistor fault (rF). Additionally, disable Stall Prevention (L3-04 = 0) when using an optional regenerative converter, regenerative or braking units, or dynamic braking option. Leaving If L3-04 enabled may prevent the drive from stopping within the specified deceleration time.
- <3> Supplying power to the control circuit separately from the main circuit requires 24 V power supply (option).
- <4> This figure illustrates an example of a sequence input to S1 through S8 using a non-powered relay or an NPN transistor. Install the wire link between terminals SC-SP for Sink mode, between SC-SN for Source mode, or leave the link out for external power supply. Never short terminals SP and SN, as it will damage the drive.
- <5> This voltage source supplies a maximum current of 150 mA.
- <6> The maximum output current capacity for the +V terminal on the control circuit is 20 mA. Never short terminals +V and AC, as it can cause erroneous operation or damage the drive.
- <7> Set jumper S1 to select between a voltage or current input signal to terminal A2. The default setting is for current input.
- <8> Set jumper S1 to select between a voltage or current input signal to terminal A1 and A3. The default setting is for voltage input.
- <9> Set DIP switch S2 to the ON position to enable the termination resistor in the last drive in a MEMOBUS/Modbus network.
- <10> H2-02 Default = F (Through Mode) in drive software versions PRG: 8551 and earlier.
- <11> Use jumper S5 to select between voltage or current output signals at terminals AM and FM. Set parameters H4-07 and H4-08 accordingly.
- <12> Monitor outputs work with devices such as analog frequency meters, ammeters, voltmeters, and wattmeters. They are not intended for use as a feedback-type signal.

**WARNING!** *Sudden Movement Hazard. Do not close the wiring for the control circuit unless the multifunction input terminal parameters are properly set. Improper sequencing of run/stop circuitry could result in death or serious injury from moving equipment.*

**WARNING!** *Sudden Movement Hazard. Ensure start/stop and safety circuits are wired properly and in the correct state before energizing the drive. Failure to comply could result in death or serious injury from moving equipment. When programmed for 3-Wire control, a momentary closure on terminal S1 may cause the drive to start.*

**WARNING!** *Sudden Movement Hazard. Confirm the drive I/O signals and external sequence before executing the application preset function. Executing the application preset function or setting A1-03 ≠ 0 will change the drive I/O terminal functions and may cause unexpected equipment operation. Failure to comply may cause death or serious injury.*

**NOTICE:** *When using the automatic fault restart function with wiring designed to shut off the power supply upon drive fault, make sure the drive does not trigger a fault output during fault restart (L5-02 = 0, default). Failure to comply will prevent the automatic fault restart function from working properly.*

## 3.2 Main Circuit Connection Diagram

Refer to diagrams in this section when wiring the main circuit of the drive. Connections may vary based on drive capacity. The DC power supply for the main circuit also provides power to the control circuit.

**NOTICE:** Do not use the negative DC bus terminal “-” as a ground terminal. This terminal is at high DC voltage potential. Improper wiring connections could damage the drive.

**NOTICE:** Route motor leads U/T1, V/T2 and W/T3 separate from all other leads to reduce possible interference and noise related issues. Failure to comply may result in abnormal operation of drive and nearby equipment.

### ◆ Three-Phase 200 V Class Models 2A0004 to 2A0081 Three-Phase 400 V Class Models 4A0002 to 4A0044 Three-Phase 600 V Class Models 5A0003 to 5A0032

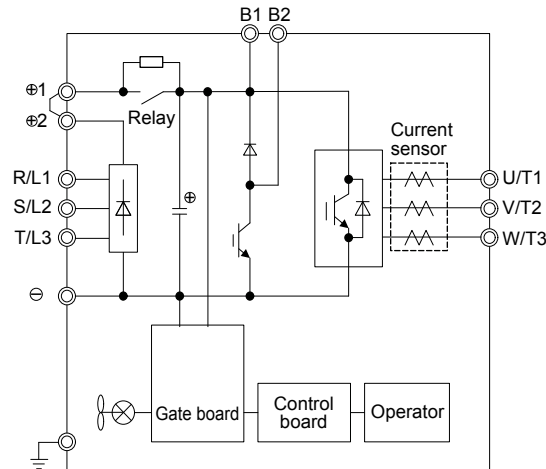

Figure 3.2 Connecting Main Circuit Terminals

### ◆ Three-Phase 200 V Class Models 2A0110, 2A0138 Three-Phase 400 V Class Models 4A0058, 4A0072 Three-Phase 600 V Class Models 5A0041, 5A0052

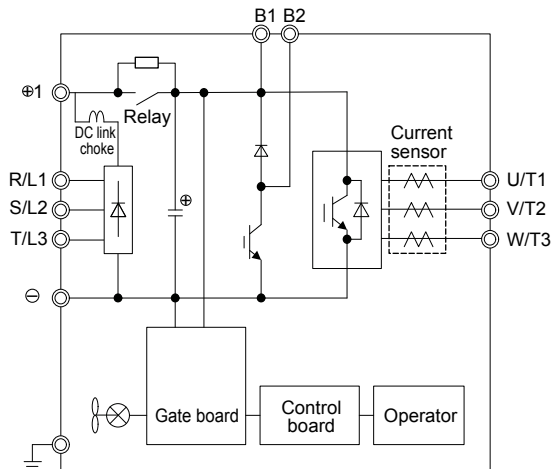

Figure 3.3 Connecting Main Circuit Terminals

### 3.2 Main Circuit Connection Diagram

- ◆ **Three-Phase 200 V Class Models 2A0169 to 2A0211**
- Three-Phase 400 V Class Models 4A0088 to 4A0139**
- Three-Phase 600 V Class Models 5A0062 to 5A0099**

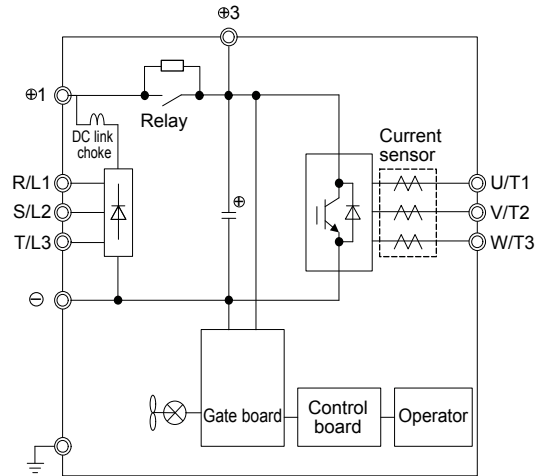

Figure 3.4 Connecting Main Circuit Terminals

- ◆ **Three-Phase 200 V Class Models 2A0250 to 2A0415**
- Three-Phase 400 V Class Models 4A0165 to 4A0675**
- Three-Phase 600 V Class Models 5A0125 to 5A0242**

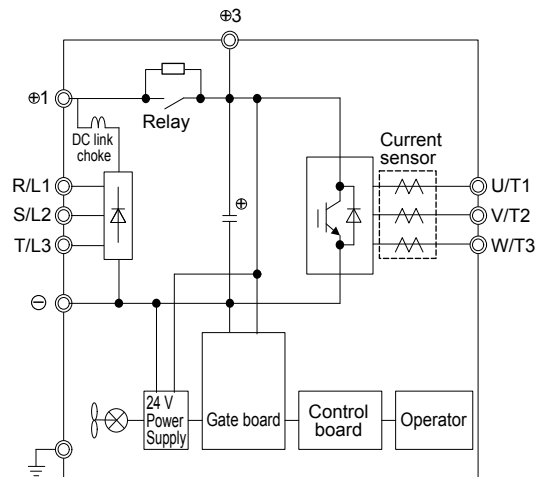

Figure 3.5 Connecting Main Circuit Terminals



### ◆ Three-Phase 400 V Class Models 4A0930, 4A1200

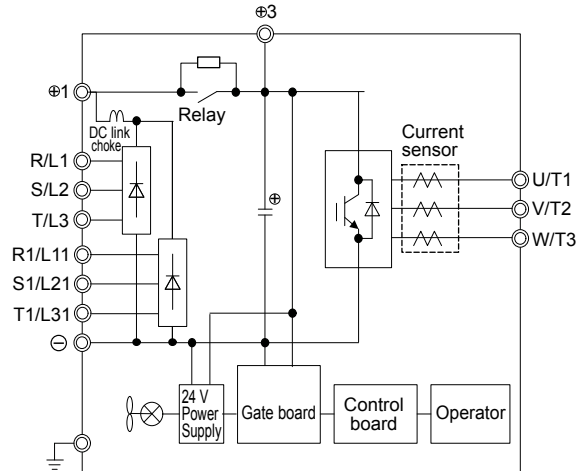

Figure 3.6 Connecting Main Circuit Terminals

**Note:** Models 4A0930 and 4A1200 are compatible for operation with 12-phase rectification. [Refer to 12-Phase Rectification on page 97](#) for details.

### ◆ Single-Phase Connections

Use terminals R/L1 and S/L2 to connect single-phase power.

### ◆ 12-Phase Rectification

#### ■ Removing the Jumper

Models 4A0930 and 4A1200 are compatible for operation with 12-phase rectification. Operation with 12-phase rectification requires the user to separately prepare a 3-winding transformer for the power supply. Contact Yaskawa or your nearest sales representative for transformer specifications.

**WARNING! Fire Hazard.** Failure to remove jumpers shorting the power supply terminals on the main circuit when operating with 12-phase rectification may cause death or serious injury by fire.

#### ■ Application Notes

Models 4A0930 and 4A1200 are shipped from the factory with jumpers short-circuiting terminals R/L1-R1/L11, S/L2-S1/L21, and T/L3-T1/L31.

Remove M5 screws and jumpers as shown in [Figure 3.7](#) to operate with 12-phase rectification.

## 3.2 Main Circuit Connection Diagram

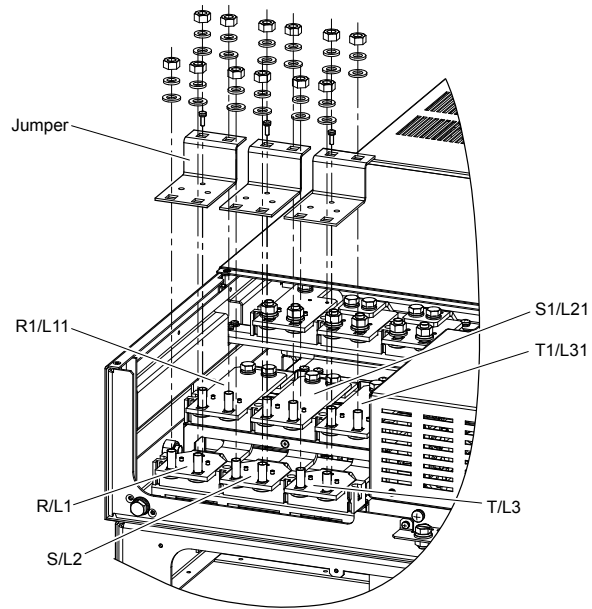

**Figure 3.7 Removing the Jumper**

### 3.3 Terminal Block Configuration

Figure 3.8 to Figure 3.11 show the different main circuit terminal arrangements for the drive capacities.

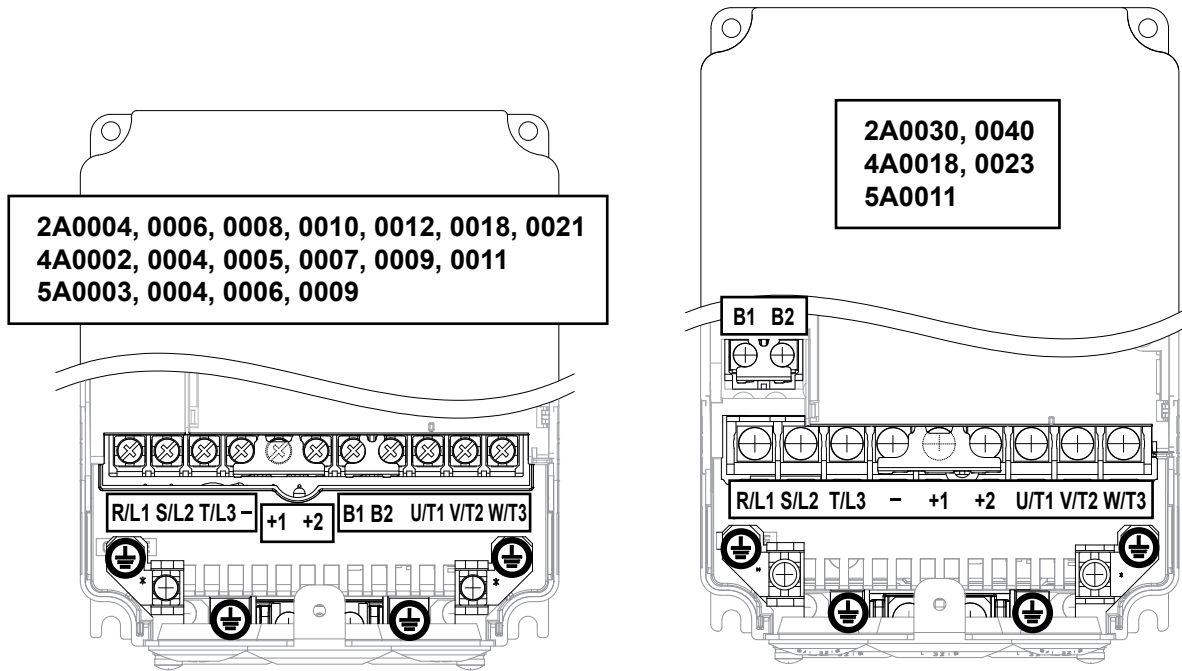

Figure 3.8 Main Circuit Terminal Block Configuration

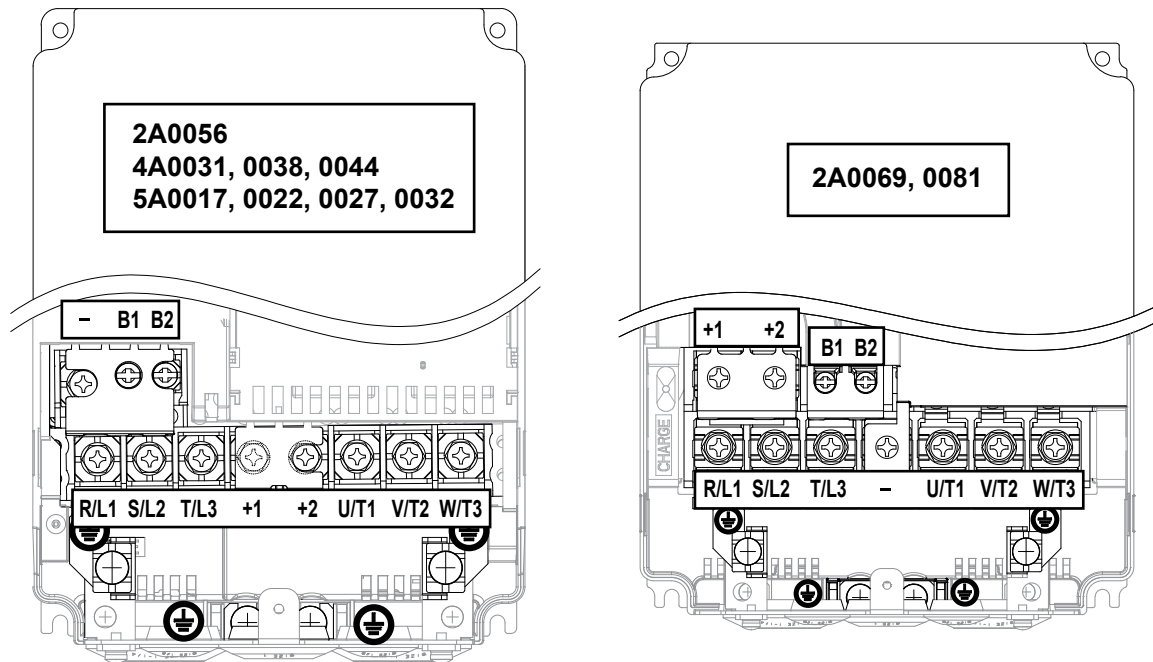

Figure 3.9 Main Circuit Terminal Block Configuration (continued)

### 3.3 Terminal Block Configuration

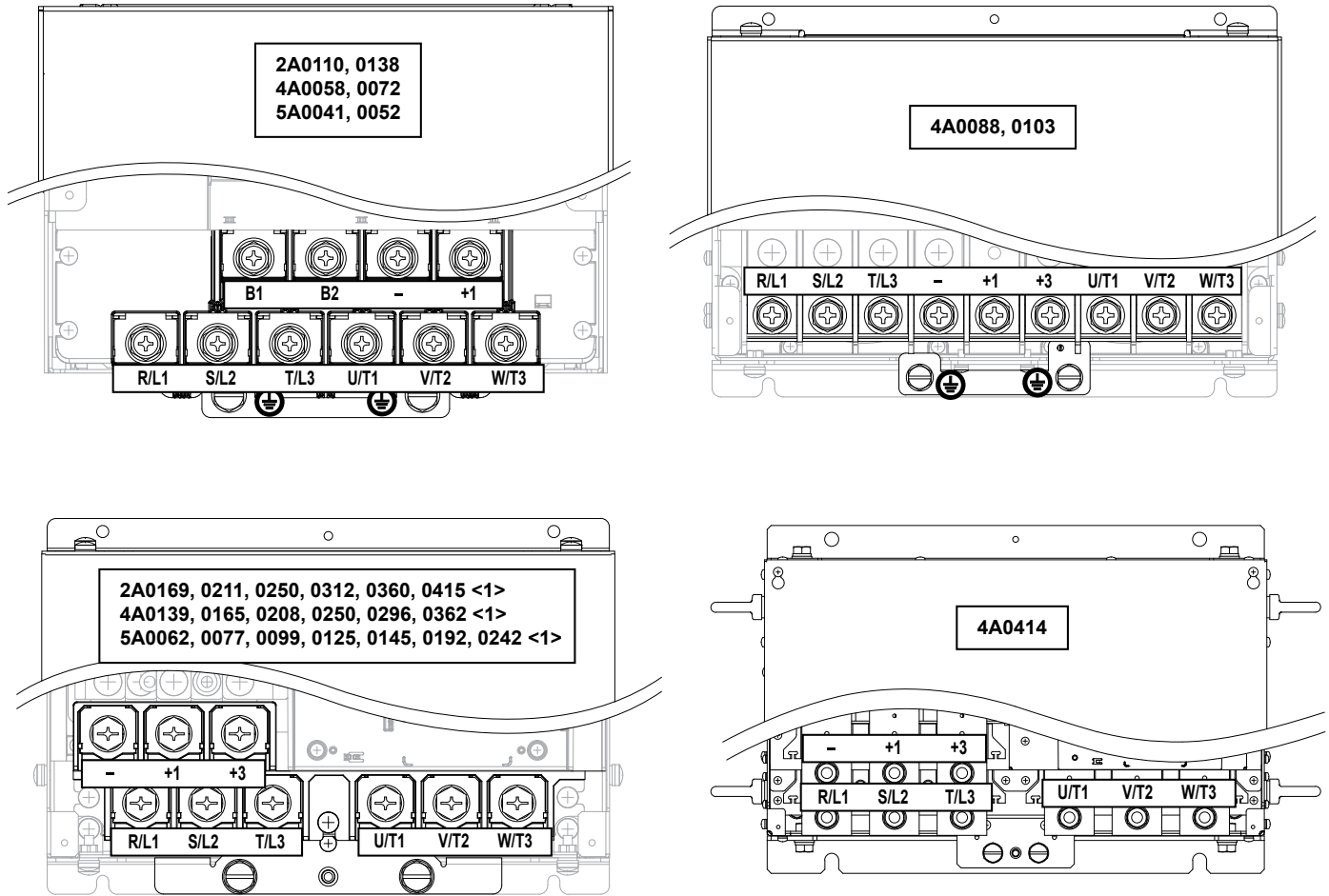

Figure 3.10 Main Circuit Terminal Block Configuration (continued)

<1> Terminal block design differs slightly for models 2A0250 to 2A0415, 4A0208 to 4A0362, and 5A0125 to 5A0242.

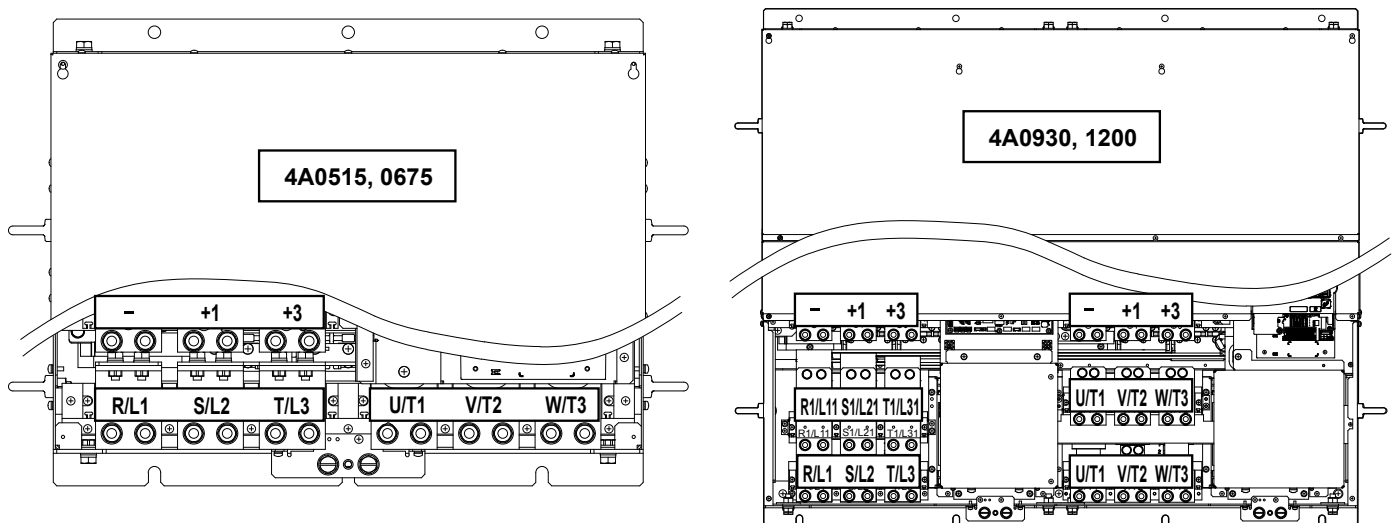

Figure 3.11 Main Circuit Terminal Block Configuration (continued)

## 3.4 Terminal Cover

Follow the procedure below to remove the terminal cover for wiring and to reattach the terminal cover after wiring is complete.

### ◆ Models 2A0004 to 2A0081, 4A0002 to 4A0044, 5A0003 to 5A0032 (IP20/NEMA 1, UL Type 1 Enclosure)

#### ■ Removing the Terminal Cover

1. Loosen the terminal cover screw using a #2 Phillips screwdriver. Screw sizes vary by drive model.

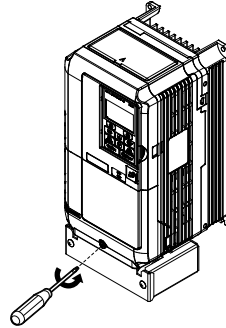

Figure 3.12 Removing the Terminal Cover on an IP20/NEMA 1, UL Type 1 Enclosure Drive

2. Push in on the tab located on the bottom of the terminal cover and gently pull forward to remove the terminal cover.

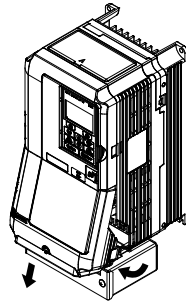

Figure 3.13 Removing the Terminal Cover on an IP20/NEMA 1, UL Type 1 Enclosure Drive

#### ■ Reattaching the Terminal Cover

Power lines and signal wiring should pass through the opening provided. *Refer to [Wiring the Main Circuit Terminal on page 119](#) and [Wiring the Control Circuit Terminal on page 123](#) for details on wiring.*

Reattach the terminal cover after completing the wiring to the drive and other devices.

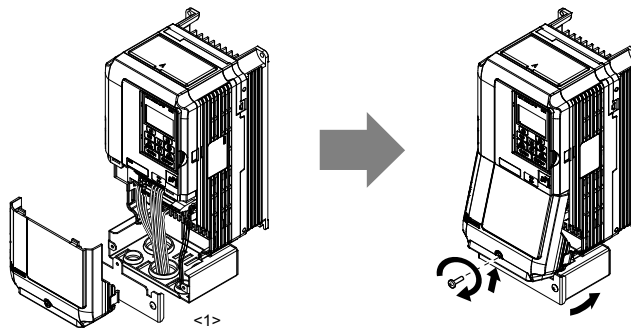

Figure 3.14 Reattaching the Terminal Cover on an IP20/NEMA 1, UL Type 1 Enclosure Drive

<1> Connect the ground wiring first, then the main circuit wiring, and finally the control circuit wiring.

### ◆ Models 2A0110 to 2A0250, 4A0208 to 4A1200, and 5A0125 to 5A0242 (IP00/Open Type Enclosure)

#### ■ Removing the Terminal Cover

1. Loosen the screws on the terminal cover, then pull down on the cover.

**Note:** The terminal cover and the number of terminal cover screws differ depending on the drive model.

**CAUTION!** Do not completely remove the cover screws, just loosen them. If the cover screws are removed completely, the terminal cover may fall off causing an injury.

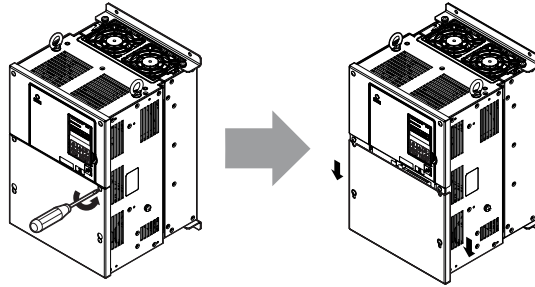

Figure 3.15 Removing the Terminal Cover on an IP00/Open Type Enclosure Drive

2. Pull forward on the terminal cover to free it from the drive.

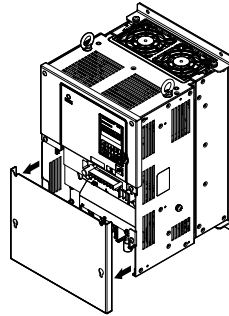

Figure 3.16 Removing the Terminal Cover on an IP00/Open Type Enclosure Drive

#### ■ Reattaching the Terminal Cover

After wiring the terminal board and other devices, double-check connections and reattach the terminal cover. *Refer to Wiring the Main Circuit Terminal on page 119* and *Wiring the Control Circuit Terminal on page 123* for details on wiring.

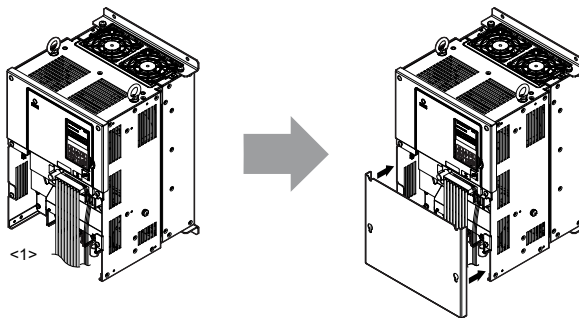

Figure 3.17 Reattaching the Terminal Cover on an IP00/Open Type Enclosure Drive

<1> Connect the ground wiring first, then the main circuit wiring, and finally the control circuit wiring.

## 3.5 HOA Keypad and Front Cover

Detach the HOA keypad from the drive for remote operation or when opening the front cover to install an option card.

**NOTICE:** Be sure to remove the HOA keypad prior to opening or reattaching the front cover. Leaving the HOA keypad plugged into the drive when removing the front cover can result in erroneous operation caused by a poor connection. Firmly fasten the front cover back into place before reattaching the HOA keypad.

### ◆ Removing/Reattaching the HOA Keypad

#### ■ Removing the HOA Keypad

While pressing on the tab located on the right side of the digital operator, pull the HOA keypad forward to remove it from the drive.

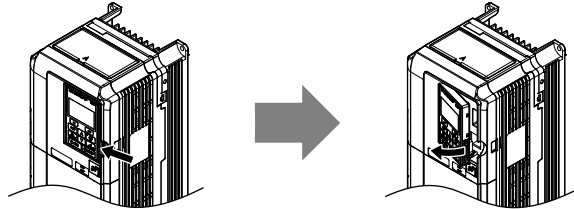

Figure 3.18 Removing the HOA Keypad

#### ■ Reattaching the HOA Keypad

Insert the HOA keypad into the opening in the top cover while aligning it with the notches on the left side of the opening. Next, press gently on the right side of the keypad until it clicks into place.

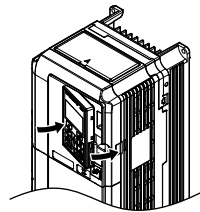

Figure 3.19 Reattaching the HOA Keypad

### ◆ Removing/Reattaching the Front Cover

#### ■ Removing the Front Cover

**Models 2A0004 to 2A0081, 4A0002 to 4A0044, and 5A0003 to 5A0032**

After removing the terminal cover and the HOA keypad, loosen the screw that affixes the front cover (models 2A0056, 4A0038, 5A0022, and 5A0027 do not use a screw to affix the front cover). Pinch in on the tabs found on each side of the front cover, then pull forward to remove it from the drive.

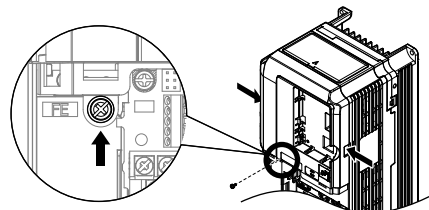
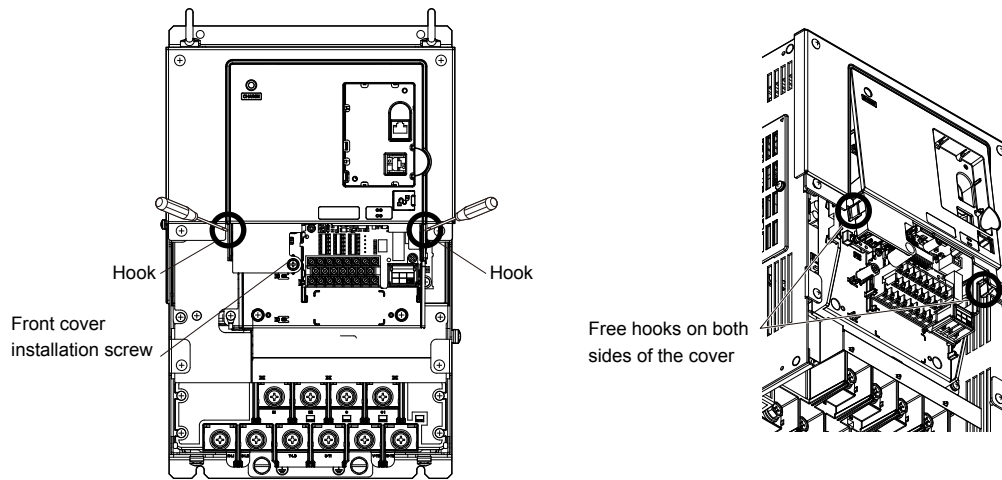

Figure 3.20 Remove the Front Cover (2A0004 to 2A0081, 4A0002 to 4A0044, and 5A0003 to 5A0032)

**Models 2A0110 to 2A0415 and 4A0058 to 4A1200**

1. Remove the terminal cover and the HOA keypad.
2. Loosen the installation screw on the front cover.
3. Use a straight-edge screwdriver to loosen the hooks on each side of the cover that hold it in place.

### 3.5 HOA Keypad and Front Cover



**Figure 3.21 Remove the Front Cover (2A0010 to 2A0415 and 4A0058 to 4A1200)**

4. Unhook the left side of the front cover then swing the left side towards you as shown in [Figure 3.22](#) until the cover comes off.

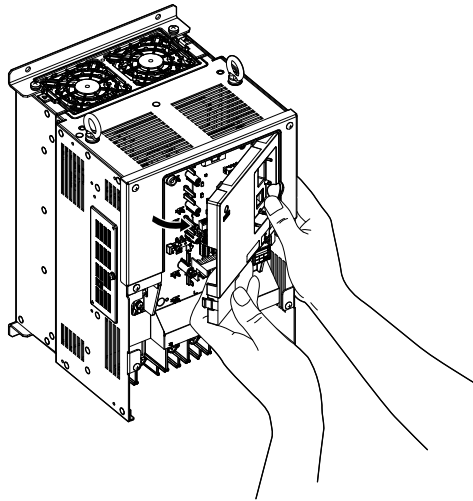

**Figure 3.22 Remove the Front Cover (2A0010 to 2A0415 and 4A0058 to 4A1200)**



## ■ Reattaching the Front Cover

### Models 2A0004 to 2A0081, 4A0002 to 4A0044, and 5A0003 to 5A0032

Reverse the instructions given in *Remove the Front Cover (2A0004 to 2A0081, 4A0002 to 4A0044, and 5A0003 to 5A0032)* on page [103](#) to reattach the front cover. Pinch inwards on the hooks found on each side of the front cover while guiding it back into the drive. Make sure it clicks firmly into place.

### Models 2A0110 to 2A0415 and 4A0058 to 4A1200

1. Slide the front cover so the hooks on the top connect to the drive.

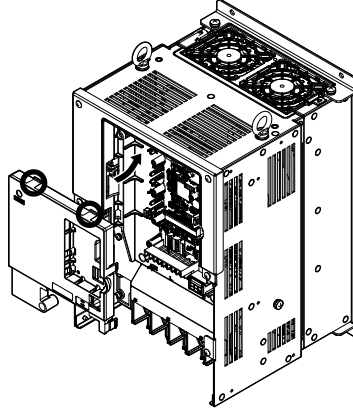

Figure 3.23 Reattach the Front Cover (2A0110 to 2A0415 and 4A0058 to 4A1200)

2. After connecting the hooks to the drive, press firmly on the cover to lock it into place.

### 3.6 Top Protective Cover

Drive models 2A0004 to 2A0081, 4A0002 to 4A0044, and 5A0003 to 5A0032 are designed to IP20/NEMA 1, UL Type 1 specifications with a protective cover on the top. Removing this top protective cover or the bottom conduit bracket from an IP20/NEMA 1, UL Type 1 enclosure drive voids the NEMA 1, UL Type 1 protection while maintaining IP20 conformity.

#### ◆ Removing the Top Protective Cover

Insert the tip of a straight-edge screwdriver into the small opening located on the front edge of the top protective cover. Gently apply pressure as shown in the figure below to free the cover from the drive.

**Note:** Removing the top protective cover or the bottom conduit bracket from an IP20/NEMA 1, UL Type 1 enclosure drive voids the NEMA 1, UL Type 1 protection while maintaining IP20 conformity.

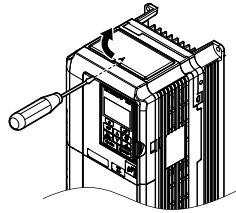

Figure 3.24 Removing the Top Protective Cover

#### ◆ Reattaching the Top Protective Cover

Insert the two small protruding hooks on the rear side of the top protective cover into the provided mounting holes near the back of the drive, then press down on the front side of the top protective cover to fasten the cover into place.

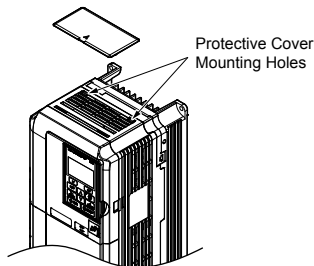

Figure 3.25 Reattaching the Protective Cover

## 3.7 Main Circuit Wiring

This section describes the functions, specifications, and procedures required to safely and properly wire the main circuit in the drive.

**NOTICE:** Do not solder the ends of wire connections to the drive. Soldered wiring connections can loosen over time. Improper wiring practices could result in drive malfunction due to loose terminal connections.

**NOTICE:** Do not switch the drive input to start or stop the motor. Frequently switching the drive on and off shortens the life of the DC bus charge circuit and the DC bus capacitors, and can cause premature drive failures. For the full performance life, refrain from switching the drive on and off more than once every 30 minutes.

**Note:** Refer to [Single-Phase Derating on page 329](#) for applying and protecting the drive when using single-phase input power.

Refer to [Factory Recommended Branch Circuit Protection for UL Compliance on page 500](#) for details on fuse selection.

### ◆ Factory Recommended Branch Circuit Protection

**WARNING! Fire Hazard.** Install adequate branch circuit protection according to applicable local codes and this manual. Failure to comply could result in fire and damage to the drive or injury to personnel. The device is suitable for use on a circuit capable of delivering not more than 100,000 RMS symmetrical amperes, 240 Vac (200 V class) and 480 Vac (400 V class), when protected by branch circuit protection devices specified in this manual.

Branch circuit protection shall be provided by any of the following: Non-time delay Class J, T, or CC fuses sized at 300% of the drive input rating, or Time delay Class J, T, or CC fuses sized at 175% of the drive input rating, or MCCB sized at 200% maximum of the drive input rating.

Yaskawa recommends installing branch circuit protection according to maintain compliance with UL508C. Semiconductor protective type fuses are preferred. Alternate branch circuit protection devices are also listed in this manual. Refer to [Factory Recommended Branch Circuit Protection on page 488](#) for details.

### ◆ Main Circuit Terminal Functions

Table 3.1 Main Circuit Terminal Functions

Terminal		Type				Function	Page
200 V Class	Drive Model	2A0004 to 2A0081	2A0110, 2A0138	2A0169 to 2A0415	–		
400 V Class		4A0002 to 4A0044	4A0058, 4A0072	4A0088 to 4A0675	4A0930, 4A1200		
600 V Class		5A0003 to 5A0032	5A0041, 5A0052	5A0062 to 5A0242	–		
R/L1	Main circuit power supply input				Connects line power to the drive	93	
S/L2							
T/L3							
R1-L11	Not available				Main circuit power supply input	Connects line power to the drive Remove the shorting bars connecting R/L1-R1/L11, S/L2-S1/L21, T/L3-T1/L31 when using 12-phase rectification.	
S1-L21							
T1-L31							
U/T1	Drive output				Connects to the motor	93	
V/T2							
W/T3							
B1	Braking resistor		Not available		Available for connecting a braking resistor or a braking resistor unit option	–	
B2							
⊕2	<ul style="list-style-type: none"> <li>DC link choke connection (⊕1, ⊕2) (remove the shorting bar between ⊕1 and ⊕2)</li> <li>DC power supply input (⊕1, ⊖)</li> </ul>	Not available				For connecting: <ul style="list-style-type: none"> <li>the drive to a DC power supply</li> <li>dynamic braking options</li> <li>a DC link choke</li> </ul>	–
⊕1							
⊖							
⊕3	Not available						

### 3.7 Main Circuit Wiring

Terminal		Type				Function	Page
200 V Class	Drive Model	2A0004 to 2A0081	2A0110, 2A0138	2A0169 to 2A0415	–		
400 V Class		4A0002 to 4A0044	4A0058, 4A0072	4A0088 to 4A0675	4A0930, 4A1200		
600 V Class		5A0003 to 5A0032	5A0041, 5A0052	5A0062 to 5A0242	–		
⊕		For 200 V class: 100 Ω or less For 400 V class: 10 Ω or less For 600 V class: 10 Ω or less				Grounding terminal	<b>118</b>

**Note:** Use terminals B1 and ⊕ when installing a CDBR-type braking unit on drives with built-in braking transistors (Models 2A0004 to 2A0138, 4A0002 to 4A0072, and 5A0003 to 5A0052).

#### Wiring Fuses for Models 4A0930 and 4A1200

**NOTICE:** If a fuse is blown or an Ground Fault Circuit Interrupter (GFCI) is tripped, check the wiring and the selection of peripheral devices to identify the cause. Contact Yaskawa before restarting the drive or the peripheral devices if the cause cannot be identified.

Install a fuse on the input side to protect drive wiring and prevent other secondary damage. Wire the fuse so that leakage current in the upper controller power supply will trigger the fuse and shut off the power supply.

Select the appropriate fuse from [Table 3.2](#).

**Table 3.2 Input Fuses for Models 4A0930 and 4A1200**

Voltage Class	Model	Selection			Input Fuse (Example)			
		Input Voltage	Current	Pre-arc $I^2t$ (A <sup>2</sup> s)	Model	Manufacturer	Rating	Pre-arc $I^2t$ (A <sup>2</sup> s)
Three-Phase 400 V Class	4A0930	480 V	1500 A	140000 to 3100000	CS5F-1200	Fuji Electric	AC500 V, 1200 A	276000
					FWH-1200A	Bussman	AC500 V, 1200 A	–
	4A1200	480 V	1500 A	320000 to 3100000	CS5F-1500	Fuji Electric	AC500 V, 1500 A	351000
					FWH-1600A	Bussman	AC500 V, 1600 A	–

## ◆ Protecting Main Circuit Terminals

### ■ Insulation Caps or Sleeves

Use insulation caps or sleeves when wiring the drive with crimp terminals. Take particular care to ensure that the wiring does not touch nearby terminals or the surrounding case.

### ■ Insulation Barrier

Insulation barriers are packaged with drive models 4A0414 through 4A1200 to provide added protection between terminals. Yaskawa recommends using the provided insulation barriers to ensure proper wiring. Refer to [Figure 3.26](#) for instructions on placement of the insulation barriers.

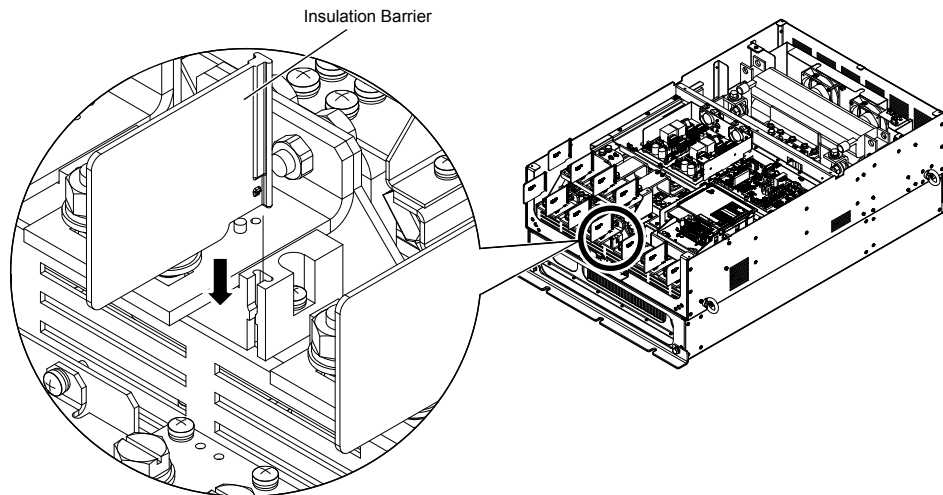

Figure 3.26 Installing Insulation Barriers

### 3.7 Main Circuit Wiring

#### ◆ Main Circuit Wire Gauges and Tightening Torques

Use the tables in this section to select the appropriate wires and crimp terminals.

Gauges listed in the tables are for use in the United States.

- Note:**
1. Wire gauge recommendations based on drive continuous current ratings (ND) using 75 °C 600 Vac vinyl-sheathed wire assuming ambient temperature within 40 °C and wiring distance less than 100 m.
  2. Terminals ⊕1, ⊕2, ⊕3, ⊖, B1 and B2 are for connecting optional power devices. Use caution to connect only approved devices to the correct terminal(s).

- Consider the amount of voltage drop when selecting wire gauges. Increase the wire gauge when the voltage drop is greater than 2% of motor rated voltage. Ensure the wire gauge is suitable for the terminal block. Use the following formula to calculate the amount of voltage drop:

$$\text{Line drop voltage (V)} = \sqrt{3} \times \text{wire resistance } (\Omega/\text{km}) \times \text{wire length (m)} \times \text{current (A)} \times 10^{-3}$$

- Refer to instruction manual TOBPC72060000 or TOBPC72060001 for braking transistor option or braking resistor option wire gauges.
- Use terminals ⊕1 and ⊖ when connecting a regenerative converter or a regen unit.

**NOTICE:** Do not connect a braking resistor to terminals ⊕1 or ⊖. Failure to comply may cause damage to the drive circuitry.

- Use terminals B1 and ⊖ when installing a CDBR-type braking unit on drives with built-in braking transistors (models 2A0004 to 2A0138, 4A0002 to 4A0072, and 5A0003 to 5A0052).

**NOTICE:** Do not connect a braking resistor to terminals ⊕1 or ⊖. Failure to comply may cause damage to the drive circuitry.

- [Refer to UL Standards Compliance on page 496](#) for information on UL compliance.

Yaskawa recommends using closed-loop crimp terminals on all drive models. UL/cUL approval requires the use of closed-loop crimp terminals when wiring the drive main circuit terminals on models 2A0110 to 2A0415 and 4A0058 to 4A1200. Use only the tools recommended by the terminal manufacturer for crimping. [Refer to Closed-Loop Crimp Terminal Size on page 496](#) for closed-loop crimp terminal recommendations.

The wire gauges listed in the following tables are Yaskawa recommendations. Refer to local codes for proper wire gauge selections.

#### ■ Three-Phase 200 V Class

**Table 3.3 Wire Gauge and Torque Specifications (Three-Phase 200 V Class)**

Drive Model	Terminal	Recomm. Gauge AWG, kcmil	Wire Range AWG, kcmil	Screw Size	Tightening Torque N·m (lb.in.)
2A0004 2A0006 2A0008 2A0010	R/L1, S/L2, T/L3	14	14 to 10	M4	1.2 to 1.5 (10.6 to 13.3)
	U/T1, V/T2, W/T3	14	14 to 10		
	⊖, ⊕1, ⊕2	–	14 to 10		
	B1, B2	–	14 to 10		
	⊕	10 </>	14 to 10		
2A0012	R/L1, S/L2, T/L3	12	14 to 10	M4	1.2 to 1.5 (10.6 to 13.3)
	U/T1, V/T2, W/T3	14	14 to 10		
	⊖, ⊕1, ⊕2	–	14 to 10		
	B1, B2	–	14 to 10		
	⊕	10 </>	14 to 10		
2A0018	R/L1, S/L2, T/L3	10	12 to 10	M4	1.2 to 1.5 (10.6 to 13.3)
	U/T1, V/T2, W/T3	10	14 to 10		
	⊖, ⊕1, ⊕2	–	14 to 10		
	B1, B2	–	14 to 10		
	⊕	10 </>	14 to 10		
2A0021	R/L1, S/L2, T/L3	10	12 to 10	M4	1.2 to 1.5 (10.6 to 13.3)
	U/T1, V/T2, W/T3	10	12 to 10		
	⊖, ⊕1, ⊕2	–	12 to 10		
	B1, B2	–	14 to 10		
	⊕	10 </>	12 to 10		

Drive Model	Terminal	Recomm. Gauge AWG, kcmil	Wire Range AWG, kcmil	Screw Size	Tightening Torque N·m (lb.in.)
2A0030	R/L1, S/L2, T/L3	8	10 to 6	M4	2.1 to 2.3 (18.6 to 20.4)
	U/T1, V/T2, W/T3	8	10 to 6		
	⊖, ⊕1, ⊕2	–	10 to 6		
	B1, B2	–	14 to 10		
	⊕	8 <2>	10 to 8	M5	2.0 to 2.5 (17.7 to 22.1)
2A0040	R/L1, S/L2, T/L3	6	8 to 6	M4	2.1 to 2.3 (18.6 to 20.4)
	U/T1, V/T2, W/T3	8	8 to 6		
	⊖, ⊕1, ⊕2	–	6		
	B1, B2	–	12 to 10		
	⊕	8 <2>	10 to 8	M5	2.0 to 2.5 (17.7 to 22.1)
2A0056	R/L1, S/L2, T/L3	4	6 to 4	M6	5.4 to 6.0 (47.8 to 53.1)
	U/T1, V/T2, W/T3	4	6 to 4		
	⊖, ⊕1, ⊕2	–	6 to 4		
	B1, B2	–	10 to 6	M5	2.7 to 3.0 (23.9 to 26.6)
	⊕	6	8 to 6	M6	5.4 to 6.0 (47.8 to 53.1)
2A0069	R/L1, S/L2, T/L3	3	4 to 3	M8	9.9 to 11.0 (87.6 to 97.4)
	U/T1, V/T2, W/T3	3	4 to 3		
	⊖, ⊕1, ⊕2	–	4 to 3		
	B1, B2	–	8 to 6	M5	2.7 to 3.0 (23.9 to 26.6)
	⊕	6	6 to 4	M6	5.4 to 6.0 (47.8 to 53.1)
2A0081	R/L1, S/L2, T/L3	2	3 to 2	M8	9.9 to 11.0 (87.6 to 97.4)
	U/T1, V/T2, W/T3	2	3 to 2		
	⊖, ⊕1, ⊕2	–	3 to 2		
	B1, B2	–	6	M5	2.7 to 3.0 (23.9 to 26.6)
	⊕	6	6 to 4	M6	5.4 to 6.0 (47.8 to 53.1)
2A0110	R/L1, S/L2, T/L3	1/0	3 to 1/0	M8	9 to 11 (79.7 to 97.4)
	U/T1, V/T2, W/T3	1/0	3 to 1/0		
	⊖, ⊕1	–	2 to 1/0		
	B1, B2	–	6 to 1/0		
	⊕	6	6 to 4		
2A0138	R/L1, S/L2, T/L3	2/0	1 to 2/0	M10	18 to 23 (159 to 204)
	U/T1, V/T2, W/T3	2/0	1 to 2/0		
	⊖, ⊕1	–	1/0 to 3/0		
	B1, B2	–	4 to 2/0		
	⊕	4	4	M8	9 to 11 (79.7 to 97.4)
2A0169	R/L1, S/L2, T/L3	4/0	2/0 to 4/0	M10	18 to 23 (159 to 204)
	U/T1, V/T2, W/T3	4/0	3/0 to 4/0		
	⊖, ⊕1	–	1 to 4/0		
	⊕3	–	1/0 to 4/0		
	⊕	4	4 to 2		
2A0211	R/L1, S/L2, T/L3	1/0 × 2P	1/0 to 2/0	M10	18 to 23 (159 to 204)
	U/T1, V/T2, W/T3	1/0 × 2P	1/0 to 2/0		
	⊖, ⊕1	–	1 to 4/0		
	⊕3	–	1/0 to 4/0		
	⊕	4	4 to 1/0		

### 3.7 Main Circuit Wiring

Drive Model	Terminal	Recomm. Gauge AWG, kcmil	Wire Range AWG, kcmil	Screw Size	Tightening Torque N·m (lb.in.)
2A0250	R/L1, S/L2, T/L3	3/0 × 2P	3/0 to 300	M12	32 to 40 (283 to 354)
	U/T1, V/T2, W/T3	3/0 × 2P	3/0 to 300		
	⊖, ⊕1	–	3/0 to 300		
	⊕3	–	2 to 300	M10	18 to 23 (159 to 204)
	⊕	3	3 to 300	M12	32 to 40 (283 to 354)
2A0312	R/L1, S/L2, T/L3	4/0 × 2P	3/0 to 300	M12	32 to 40 (283 to 354)
	U/T1, V/T2, W/T3	3/0 × 2P	3/0 to 300		
	⊖, ⊕1	–	3/0 to 300		
	⊕3	–	3/0 to 300	M10	18 to 23 (159 to 204)
	⊕	2	2 to 300	M12	32 to 40 (283 to 354)
2A0360	R/L1, S/L2, T/L3	250 × 2P	4/0 to 600	M12	32 to 40 (283 to 354)
	U/T1, V/T2, W/T3	4/0 × 2P	4/0 to 600		
	⊖, ⊕1	–	250 to 600		
	⊕3	–	3/0 to 600	M10	18 to 23 (159 to 204)
	⊕	1	1 to 350	M12	32 to 40 (283 to 354)
2A0415	R/L1, S/L2, T/L3	350 × 2P	250 to 600	M12	32 to 40 (283 to 354)
	U/T1, V/T2, W/T3	300 × 2P	300 to 600		
	⊖, ⊕1	–	300 to 600		
	⊕3	–	3/0 to 600	M10	18 to 23 (159 to 204)
	⊕	1	1 to 350	M12	32 to 40 (283 to 354)

<1> Install a GFCI when using this wire gauge in accordance with IEC/EN 61800-5-1.

<2> Install a GFCI, or use 10 mm<sup>2</sup> (AWG 8) copper wire when using this wire gauge in accordance with IEC/EN 61800-5-1.

**Note:** When connecting peripheral devices or options to terminals ⊖, ⊕1, ⊕3, B1, and B2, refer to the instruction manual for each device. For more information, contact Yaskawa or your nearest sales representative.

### ■ Three-Phase 400 V Class

Table 3.4 Wire Gauge and Torque Specifications (Three-Phase 400 V Class)

Drive Model	Terminal	Recomm. Gauge AWG, kcmil	Wire Range AWG, kcmil	Screw Size	Tightening Torque N·m (lb.in.)
4A0002 4A0004	R/L1, S/L2, T/L3	14	14 to 10	M4	1.2 to 1.5 (10.6 to 13.3)
	U/T1, V/T2, W/T3	14	14 to 10		
	⊖, ⊕1, ⊕2	–	14 to 10		
	B1, B2	–	14 to 10		
	⊕	12 </>	14 to 12		
4A0005 4A0007 4A0009	R/L1, S/L2, T/L3	14	14 to 10	M4	1.2 to 1.5 (10.6 to 13.3)
	U/T1, V/T2, W/T3	14	14 to 10		
	⊖, ⊕1, ⊕2	–	14 to 10		
	B1, B2	–	14 to 10		
	⊕	10 </>	14 to 10		
4A0011	R/L1, S/L2, T/L3	12	14 to 10	M4	1.2 to 1.5 (10.6 to 13.3)
	U/T1, V/T2, W/T3	14	14 to 10		
	⊖, ⊕1, ⊕2	–	14 to 10		
	B1, B2	–	14 to 10		
	⊕	10 </>	14 to 10		



Drive Model	Terminal	Recomm. Gauge AWG, kcmil	Wire Range AWG, kcmil	Screw Size	Tightening Torque N·m (lb.in.)
4A0018	R/L1, S/L2, T/L3	10	12 to 6	M4	2.1 to 2.3 (18.6 to 20.4)
	U/T1, V/T2, W/T3	10	12 to 6		
	⊖, ⊕1, ⊕2	–	12 to 6		
	B1, B2	–	12 to 10		
	⊕	10 <?>	14 to 10	M5	2.0 to 2.5 (17.7 to 22.1)
4A0023	R/L1, S/L2, T/L3	10	10 to 6	M4	2.1 to 2.3 (18.6 to 20.4)
	U/T1, V/T2, W/T3	10	10 to 6		
	⊖, ⊕1, ⊕2	–	12 to 6		
	B1, B2	–	12 to 10		
	⊕	10 <?>	12 to 10	M5	2.0 to 2.5 (17.7 to 22.1)
4A0031	R/L1, S/L2, T/L3	8	8 to 6	M5	3.6 to 4.0 (31.8 to 35.4)
	U/T1, V/T2, W/T3	8	10 to 6		
	⊖, ⊕1, ⊕2	–	10 to 6		
	B1, B2	–	10 to 8		
	⊕	8 <?>	10 to 8	M6	5.4 to 6.0 (47.8 to 53.1)
4A0038	R/L1, S/L2, T/L3	6	8 to 6	M5	3.6 to 4.0 (31.8 to 35.4)
	U/T1, V/T2, W/T3	8	8 to 6		
	⊖, ⊕1, ⊕2	–	6		
	B1, B2	–	10 to 8		
	⊕	6	10 to 6	M6	5.4 to 6.0 (47.8 to 53.1)
4A0044	R/L1, S/L2, T/L3	6	6 to 4	M6	5.4 to 6.0 (47.8 to 53.1)
	U/T1, V/T2, W/T3	6	6 to 4		
	⊖, ⊕1, ⊕2	–	6 to 4		
	B1, B2	–	10 to 8	M5	2.7 to 3.0 (23.9 to 26.6)
	⊕	6	8 to 6	M6	5.4 to 6.0 (47.8 to 53.1)
4A0058	R/L1, S/L2, T/L3	4	6 to 4	M8	9 to 11 (79.7 to 97.4)
	U/T1, V/T2, W/T3	4	6 to 4		
	⊖, ⊕1	–	6 to 1		
	B1, B2	–	8 to 4		
	⊕	6	8 to 6		
4A0072	R/L1, S/L2, T/L3	3	4 to 3	M8	9 to 11 (79.7 to 97.4)
	U/T1, V/T2, W/T3	3	4 to 3		
	⊖, ⊕1	–	4 to 1		
	B1, B2	–	6 to 3		
	⊕	6	6		
4A0088	R/L1, S/L2, T/L3	2	3 to 1/0	M8	9 to 11 (79.7 to 97.4)
	U/T1, V/T2, W/T3	2	3 to 1/0		
	⊖, ⊕1	–	3 to 1/0		
	⊕3	–	6 to 1/0		
	⊕	4	6 to 4		
4A0103	R/L1, S/L2, T/L3	1/0	2 to 1/0	M8	9 to 11 (79.7 to 97.4)
	U/T1, V/T2, W/T3	1	2 to 1/0		
	⊖, ⊕1	–	3 to 1/0		
	⊕3	–	4 to 1/0		
	⊕	4	6 to 4		

### 3.7 Main Circuit Wiring

Drive Model	Terminal	Recomm. Gauge AWG, kcmil	Wire Range AWG, kcmil	Screw Size	Tightening Torque N·m (lb.in.)
4A0139	R/L1, S/L2, T/L3	3/0	1/0 to 4/0	M10	18 to 23 (159 to 204)
	U/T1, V/T2, W/T3	2/0	1/0 to 4/0		
	⊖, ⊕1	–	1/0 to 4/0		
	⊕3	–	3 to 4/0		
	⊕	4	4		
4A0165	R/L1, S/L2, T/L3	4/0	3/0 to 4/0	M10	18 to 23 (159 to 204)
	U/T1, V/T2, W/T3	4/0	3/0 to 4/0		
	⊖, ⊕1	–	1 to 4/0		
	⊕3	–	1/0 to 4/0		
	⊕	4	4 to 2		
4A0208	R/L1, S/L2, T/L3	300	2 to 300	M10	18 to 23 (159 to 204)
	U/T1, V/T2, W/T3	300	2 to 300		
	⊖, ⊕1	–	1 to 250		
	⊕3	–	3 to 3/0		
	⊕	4	4 to 300		
4A0250	R/L1, S/L2, T/L3	400	1 to 600	M10	18 to 23 (159 to 204)
	U/T1, V/T2, W/T3	400	1/0 to 600		
	⊖, ⊕1	–	3/0 to 600		
	⊕3	–	1 to 325		
	⊕	2	2 to 350		
4A0296	R/L1, S/L2, T/L3	500	2/0 to 600	M12	32 to 40 (283 to 354)
	U/T1, V/T2, W/T3	500	2/0 to 600		
	⊖, ⊕1	–	3/0 to 600	M10	18 to 23 (159 to 204)
	⊕3	–	1 to 325		
	⊕	2	2 to 350		
4A0362	R/L1, S/L2, T/L3	4/0 × 2P	3/0 to 600	M12	32 to 40 (283 to 354)
	U/T1, V/T2, W/T3	4/0 × 2P	3/0 to 600		
	⊖, ⊕1	–	4/0 to 600	M10	18 to 23 (159 to 204)
	⊕3	–	3/0 to 600		
	⊕	1	1 to 350		
4A0414	R/L1, S/L2, T/L3	300 × 2P	4/0 to 300	M12	32 to 40 (283 to 354)
	U/T1, V/T2, W/T3	300 × 2P	4/0 to 300		
	⊖, ⊕1	–	3/0 to 300		
	⊕3	–	3/0 to 300		
	⊕	1	1 to 3/0		
4A0515	R/L1, S/L2, T/L3	3/0 × 4P	3/0 to 300	M12	32 to 40 (283 to 354)
	U/T1, V/T2, W/T3	4/0 × 4P	3/0 to 300		
	⊖, ⊕1	–	1/0 to 300		
	⊕3	–	1/0 to 300		
	⊕	1/0	1/0 to 300		
4A0675	R/L1, S/L2, T/L3	300 × 4P	4/0 to 300	M12	32 to 40 (283 to 354)
	U/T1, V/T2, W/T3	300 × 4P	4/0 to 300		
	⊖, ⊕1	–	1/0 to 300		
	⊕3	–	1/0 to 300		
	⊕	2/0	2/0 to 300		

Drive Model	Terminal	Recomm. Gauge AWG, kcmil	Wire Range AWG, kcmil	Screw Size	Tightening Torque N·m (lb.in.)
4A0930	R/L1, S/L2, T/L3, R1/L11, S1/L21, T1/L31	4/0 × 4P×2	3/0 to 300	M12	32 to 40 (283 to 354)
	U/T1, V/T2, W/T3	4/0 × 4P×2	3/0 to 300		
	⊖, ⊕1	–	4/0 to 300		
	⊕3	–	4/0 to 300		
	⊕	3/0	3/0 to 250		
4A1200	R/L1, S/L2, T/L3, R1/L11, S1/L21, T1/L31	300 × 4P×2	4/0 to 300	M12	32 to 40 (283 to 354)
	U/T1, V/T2, W/T3	300 × 4P×2	4/0 to 300		
	⊖, ⊕1	–	250 to 300		
	⊕3	–	4/0 to 300		
	⊕	4/0	4/0 to 250		

<1> Install a GFCI when using this wire gauge in accordance with IEC/EN 61800-5-1.

<2> Install a GFCI or use 10 mm<sup>2</sup> (AWG 8) copper wire when using this wire gauge in accordance with IEC/EN 61800-5-1.

**Note:** When connecting peripheral devices or options to terminals ⊖, ⊕1, ⊕3, B1, and B2, refer to the instruction manual for each device. For more information, contact Yaskawa or your nearest sales representative.

### ■ Three-Phase 600 V Class

**Table 3.5 Wire Gauge and Torque Specifications (Three-Phase 600 V Class)**

Drive Model	Terminal	Recomm. Gauge mm <sup>2</sup> (AWG, kcmil)	Wire Range mm <sup>2</sup> (AWG, kcmil)	Screw Size	Tightening Torque N·m (lb.in.)
5A0003 5A0004 5A0006	R/L1, S/L2, T/L3	2.5 (14)	2.5 to 6.0 (14 to 10)	M4	1.2 to 1.5 (10.6 to 13.3)
	U/T1, V/T2, W/T3	2.5 (14)	2.5 to 6.0 (14 to 10)		
	⊖, ⊕1, ⊕2	–	2.5 to 6.0 (14 to 10)		
	B1, B2	–	2.5 to 6.0 (14 to 10)		
	⊕	6.0 (10)	2.5 to 6.0 (14 to 10)		
5A0009	R/L1, S/L2, T/L3	2.5 (14)	2.5 to 6.0 (14 to 10)	M4	1.2 to 1.5 (10.6 to 13.3)
	U/T1, V/T2, W/T3	2.5 (14)	2.5 to 6.0 (14 to 10)		
	⊖, ⊕1, ⊕2	–	2.5 to 6.0 (14 to 10)		
	B1, B2	–	2.5 to 6.0 (14 to 10)		
	⊕	6.0 (10)	4.0 to 6.0 (12 to 10)		
5A0011	R/L1, S/L2, T/L3	6.0 (10)	2.5 to 16 (14 to 6)	M4	2.1 to 2.3 (18.6 to 20.4)
	U/T1, V/T2, W/T3	2.5 (14)	2.5 to 16 (14 to 6)		
	⊖, ⊕1, ⊕2	–	2.5 to 16 (14 to 6)		
	B1, B2	–	2.5 to 6.0 (14 to 10)		
	⊕	10 (8)	4.0 to 6.0 (12 to 8)	M5	2.0 to 2.5 (17.7 to 22.1)

### 3.7 Main Circuit Wiring

Drive Model	Terminal	Recomm. Gauge mm <sup>2</sup> (AWG, kcmil)	Wire Range mm <sup>2</sup> (AWG, kcmil)	Screw Size	Tightening Torque N·m (lb.in.)
5A0017	R/L1, S/L2, T/L3	6.0 (10)	6.0 to 16 (10 to 6)	M5	3.6 to 4.0 (31.8 to 35.4)
	U/T1, V/T2, W/T3	6.0 (10)	6.0 to 16 (10 to 6)		
	⊖, ⊕1, ⊕2	–	6.0 to 16 (10 to 6)		
	B1, B2	–	6.0 to 10 (10 to 8)		
	⊕	10 (8)	6.0 to 10 (12 to 8)	M6	2.7 to 3.0 (23.9 to 26.6)
5A0022	R/L1, S/L2, T/L3	10 (8)	6.0 to 16 (10 to 6)	M5	3.6 to 4.0 (31.8 to 35.4)
	U/T1, V/T2, W/T3	6.0 (10)	6.0 to 16 (10 to 6)		
	⊖, ⊕1, ⊕2	–	6.0 to 16 (10 to 6)		
	B1, B2	–	6.0 to 10 (10 to 8)		
	⊕	10 (8)	6.0 to 10 (10 to 6)	M6	2.7 to 3.0 (23.9 to 26.6)
5A0027 5A0032	R/L1, S/L2, T/L3	16 (6)	16 to 25 (6 to 4)	M6	5.4 to 6.0 (47.8 to 53.1)
	U/T1, V/T2, W/T3	16 (6)	16 to 25 (6 to 4)		
	⊖, ⊕1, ⊕2	–	16 to 25 (6 to 4)		
	B1, B2	–	6.0 to 10 (10 to 8)	M5	2.7 to 3.0 (23.9 to 26.6)
	⊕	16 (6)	10 to 16 (10 to 6)	M6	5.4 to 6.0 (47.8 to 53.1)
5A0041	R/L1, S/L2, T/L3	16 (6)	6.0 to 25 (10 to 3)	M8	9.0 to 11 (79.7 to 97.4)
	U/T1, V/T2, W/T3	16 (6)	6.0 to 25 (10 to 3)		
	⊖, ⊕1	–	(6 to 1)		
	B1, B2	–	4.0 to 25 (12 to 3)		
	⊕	16 (6)	10 to 16 (6)		
5A0052	R/L1, S/L2, T/L3	25 (4)	6.0 to 25 (10 to 3)	M8	9.0 to 11 (79.7 to 97.4)
	U/T1, V/T2, W/T3	16 (6)	6.0 to 25 (10 to 3)		
	⊖, ⊕1	–	16 to 35 (6 to 1)		
	B1, B2	–	10 to 25 (8 to 3)		
	⊕	16 (6)	10 to 16 (6)		
5A0062	R/L1, S/L2, T/L3	25 (4)	6.0 to 95 (10 to 4/0)	M10	18 to 23 (159 to 204)
	U/T1, V/T2, W/T3	25 (4)	6.0 to 95 (10 to 4/0)		
	⊖, ⊕1	–	25 to 95 (4 to 4/0)		
	⊕3	–	16 to 95 (6 to 4/0)		
	⊕	25 (4)	25 (4)		

Drive Model	Terminal	Recomm. Gauge mm <sup>2</sup> (AWG, kcmil)	Wire Range mm <sup>2</sup> (AWG, kcmil)	Screw Size	Tightening Torque N·m (lb.in.)
5A0077	R/L1, S/L2, T/L3	25 (3)	6.0 to 95 (10 to 4/0)	M10	18 to 23 (159 to 204)
	U/T1, V/T2, W/T3	25 (3)	6.0 to 95 (10 to 4/0)		
	⊖, ⊕1	–	25 to 95 (3 to 4/0)		
	⊕3	–	16 to 95 (6 to 4/0)		
	⊕	25 (4)	25 (4)		
5A0099	R/L1, S/L2, T/L3	70 (1/0)	6.0 to 95 (10 to 4/0)	M10	18 to 23 (159 to 204)
	U/T1, V/T2, W/T3	50 (1)	6.0 to 95 (10 to 4/0)		
	⊖, ⊕1	–	35 to 95 (2 to 4/0)		
	⊕3	–	25 to 95 (4 to 4/0)		
	⊕	25 (4)	25 (4)		
5A0125	R/L1, S/L2, T/L3	70 (2/0)	35 to 150 (1 to 300)	M10	18 to 23 (159 to 204)
	U/T1, V/T2, W/T3	70 (2/0)	35 to 150 (1 to 300)		
	⊖, ⊕1	–	70 (2/0 to 3/0)		
	⊕3	–	35 to 50 (1 to 1/0)		
	⊕	35 (3)	35 to 150 (3 to 300)		
5A0145	R/L1, S/L2, T/L3	95 (3/0)	95 to 150 (2/0 to 300)	M10	18 to 23 (159 to 204)
	U/T1, V/T2, W/T3	95 (3/0)	95 to 150 (2/0 to 300)		
	⊖, ⊕1	–	70 to 95 (3/0 to 4/0)		
	⊕3	–	70 to 95 (1/0 to 2/0)		
	⊕	35 (3)	35 to 150 (3 to 300)		
5A0192	R/L1, S/L2, T/L3	185 (300)	95 to 300 (2/0 to 600)	M12	32 to 40 (283 to 354)
	U/T1, V/T2, W/T3	150 (250)	95 to 300 (2/0 to 600)		
	⊖, ⊕1	–	95 to 185 (2/0 to 400)	M10	18 to 23 (159 to 204)
	⊕3	–	95 to 120 (2/0 to 250)		
	⊕	50 (1)	35 to 300 (1 to 350)		
5A0242	R/L1, S/L2, T/L3	240 (400)	95 to 300 (2/0 to 600)	M12	32 to 40 (283 to 354)
	U/T1, V/T2, W/T3	185 (350)	95 to 300 (2/0 to 600)		
	⊖, ⊕1	–	95 to 240 (2/0 to 500)	M10	18 to 23 (159 to 204)
	⊕3	–	150 (250 to 300)		
	⊕	50 (1)	35 to 300 (1 to 350)		

**Note:** When connecting peripheral devices or options to terminals ⊖, ⊕1, ⊕3, B1, and B2, refer to the instruction manual for each device. For more information, contact Yaskawa or your nearest sales representative.

#### ◆ Main Circuit Terminal and Motor Wiring

This section outlines the various steps, precautions, and checkpoints for wiring the main circuit terminals and motor terminals.

**WARNING! Electrical Shock Hazard.** Do not connect the AC power line to the output terminals of the drive. Failure to comply could result in death or serious injury by fire as a result of drive damage from line voltage application to output terminals.

**NOTICE:** When connecting the motor to the drive output terminals U/T1, V/T2, and W/T3, the phase order for the drive and motor should match. Failure to comply with proper wiring practices may cause the motor to run in reverse if the phase order is backward.

**NOTICE:** Route motor leads U/T1, V/T2, and W/T3 separate from all other leads to reduce possible interference related issues. Failure to comply may result in abnormal operation of drive and nearby equipment.

**NOTICE:** Do not connect phase-advancing capacitors or LC/RC noise filters to the output circuits. Failure to comply could result in damage to the drive, phase-advancing capacitors, LC/RC noise filters or ground fault circuit interrupters.

#### ■ Cable Length Between Drive and Motor

Voltage drop along the motor cable may cause reduced motor torque when the wiring between the drive and the motor is too long, especially at low frequency output. This can also be a problem when motors are connected in parallel with a fairly long motor cable. Drive output current will increase as the leakage current from the cable increases. An increase in leakage current may trigger an overcurrent situation and weaken the accuracy of the current detection.

Adjust the drive carrier frequency according to [Table 3.6](#). If the motor wiring distance exceeds 100 m because of the system configuration, reduce the ground currents.

**Table 3.6 Cable Length Between Drive and Motor**

Cable Length	50 m or less	100 m or less	Greater than 100 m
Carrier Frequency	15 kHz or less	5 kHz or less	2 kHz or less

**Note:** When setting carrier frequency for drives running multiple motors, calculate cable length as the total wiring distance to all connected motors.

#### ■ Ground Wiring

Follow the precautions below when wiring the ground for one drive or a series of drives.

**WARNING! Electrical Shock Hazard.** Make sure the protective earthing conductor complies with technical standards and local safety regulations. Because the leakage current exceeds 3.5 mA in models 4A0414 and larger, IEC/EN 61800-5-1 states that either the power supply must be automatically disconnected in case of discontinuity of the protective earthing conductor or a protective earthing conductor with a cross-section of at least 10 mm<sup>2</sup> (Cu) or 16 mm<sup>2</sup> (Al) must be used. Failure to comply may result in death or serious injury.

**WARNING! Electrical Shock Hazard.** Always use a ground wire that complies with technical standards on electrical equipment and minimize the length of the ground wire. Improper equipment grounding may cause dangerous electrical potentials on equipment chassis, which could result in death or serious injury.

**WARNING! Electrical Shock Hazard.** Be sure to ground the drive ground terminal (200 V class: ground to 100 Ω or less; 400 V class: ground to 10 Ω or less; 600 V class: ground to 10 Ω or less). Improper equipment grounding could result in death or serious injury by contacting ungrounded electrical equipment.

**NOTICE:** Do not share the ground wire with other devices such as welding machines or large-current electrical equipment. Improper equipment grounding could result in drive or equipment malfunction due to electrical interference.

**NOTICE:** When using more than one drive, ground multiple drives according to instructions. Improper equipment grounding could result in abnormal operation of drive or equipment.

Refer to [Figure 3.27](#) when using multiple drives. Do not loop the ground wire.

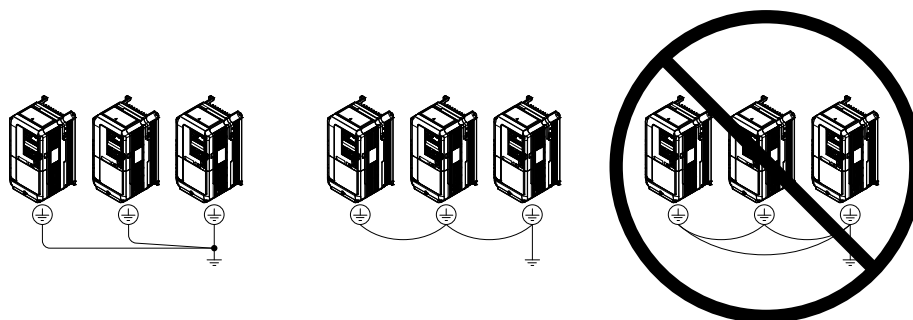

**Figure 3.27 Multiple Drive Wiring**

### ■ Wiring the Main Circuit Terminal

**WARNING!** *Electrical Shock Hazard. Shut off the power supply to the drive before wiring the main circuit terminals. Failure to comply may result in death or serious injury.*

Wire the main circuit terminals after the terminal board has been properly grounded.

Models 2A0004 to 2A0081, 4A0002 to 4A0044, and 5A0003 to 5A0032 have a cover placed over the DC bus and braking circuit terminals prior to shipment to help prevent miswiring. Use wire cutters to cut away covers as needed for terminals.

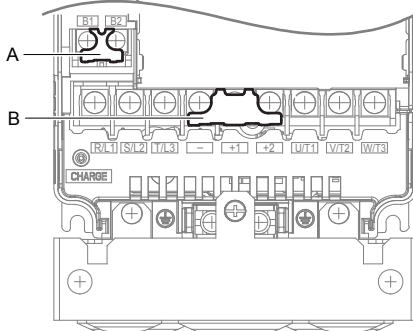

A – Braking circuit protective cover

B – DC bus protective cover

Figure 3.28 Protecting Cover to Prevent Miswiring (Model 5A0011)

### ■ Main Circuit Connection Diagram

*Refer to Main Circuit Connection Diagram on page 95* when wiring terminals on the main power circuit of the drive.

**WARNING!** *Fire Hazard. The braking resistor connection terminals are B1 and B2. Do not connect braking resistors to any other terminals. Improper wiring connections could cause the braking resistor to overheat and cause death or serious injury by fire. Failure to comply may result in damage to the braking circuit or drive.*

## 3.8 Control Circuit Wiring

### ◆ Control Circuit Terminal Block Functions

Drive parameters determine which functions apply to the multi-function digital inputs (S1 to S8), multi-function digital outputs (M1 to M4), multi-function analog inputs (A1 to A3), and multi-function analog monitor output (FM, AM). The default setting is listed next to each terminal in [Figure 3.1](#) on page 93.

**WARNING!** *Sudden Movement Hazard. Always check the operation and wiring of control circuits after being wired. Operating a drive with untested control circuits could result in death or serious injury.*

**WARNING!** *Sudden Movement Hazard. Confirm the drive I/O signals and external sequence before starting test run. Setting parameter A1-03 may change the I/O terminal function automatically from the factory setting. Failure to comply may result in death or serious injury.*

### ■ Input Terminals

[Table 3.7](#) lists the input terminals on the drive. Text in parenthesis indicates the default setting for each multi-function input.

**Table 3.7 Control Circuit Input Terminals**

Type	No.	Terminal Name (Function)	Function (Signal Level) Default Setting	Page
Multi-Function Digital Inputs	S1	Multi-function input 1 (Closed: Forward run, Open: Stop)	<ul style="list-style-type: none"> <li>• Photocoupler</li> <li>• 24 Vdc, 8 mA</li> <li>• <a href="#">Refer to Sinking/Sourcing Mode for Digital Inputs on page 125.</a></li> </ul>	373
	S2	Multi-function input 2 (Through mode)		
	S3	Multi-function input 3 (External pump fault, N.O.)		
	S4	Multi-function input 4 (Fault reset)		
	S5	Multi-function input 5 (Multi setpoint 1)		
	S6	Multi-function input 6 (HAND mode)		
	S7	Multi-function input 7 (HAND mode 2)		
	S8	Multi-function input 8 (Through mode)		
	SC	Multi-function input common	Multi-function input common	
	SP	Digital input power supply +24 Vdc	24 Vdc power supply for digital inputs, 150 mA max	125
SN	Digital input power supply 0 V 24 V transducer power supply 0 V	<b>NOTICE:</b> Do not jumper or short terminals SP and SN. Failure to comply will damage the drive.	125	
Analog Inputs / Pulse Train Input	RP	Multi-function pulse train input (Frequency reference)	<ul style="list-style-type: none"> <li>• Input frequency range: 0 to 32 kHz</li> <li>• Signal Duty Cycle: 30 to 70%</li> <li>• High level: 3.5 to 13.2 Vdc, low level: 0.0 to 0.8 Vdc</li> <li>• Input impedance: 3 kΩ</li> </ul>	217 387
	+V	Power supply for analog inputs	10.5 Vdc (maximum allowable current 20 mA)	215
	24 V	+24 Vdc transducer power supply for customer use	150 mA maximum capacity	–
	A1	Multi-function analog input 1 (Frequency reference bias)	<ul style="list-style-type: none"> <li>• -10 to 10 Vdc, 0 to 10 Vdc (input impedance: 20 kΩ)</li> <li>• 4 to 20 mA, 0 to 20 mA (input impedance: 250 Ω)</li> <li>• Voltage or current input must be selected by jumper S1 and H3-01.</li> </ul>	215 225
	A2	Multi-function analog input 2 (PID feedback)	<ul style="list-style-type: none"> <li>• -10 to 10 Vdc, 0 to 10 Vdc (input impedance: 20 kΩ)</li> <li>• 4 to 20 mA, 0 to 20 mA (input impedance: 250 Ω)</li> <li>• Voltage or current input must be selected by jumper S1 and H3-09.</li> </ul>	215 215 227
	A3	Multi-function analog input 3 (HAND frequency reference)	<ul style="list-style-type: none"> <li>• -10 to 10 Vdc, 0 to 10 Vdc (input impedance: 20 kΩ)</li> <li>• 4 to 20 mA, 0 to 20 mA (input impedance: 250 Ω)</li> <li>• Voltage or current input must be selected by jumper S1 and H3-05.</li> </ul>	215
	AC	Frequency reference common	0 V	215
	E (G)	Ground for shielded lines and option cards	–	–



## Output Terminals

Table 3.8 lists the output terminals on the drive. Text in parenthesis indicates the default setting for each multi-function output.

Table 3.8 Control Circuit Output Terminals

Type	No.	Terminal Name (Function)	Function (Signal Level) Default Setting	Page
Fault Relay Output	MA	N.O.	30 Vdc, 10 mA to 1 A; 250 Vac, 10 mA to 1 A Minimum load: 5 Vdc, 10 mA	223
	MB	N.C. output		
	MC	Fault output common		
Multi-Function Digital Output <I>	MD	N.O.	30 Vdc, 10 mA to 1 A; 250 Vac, 10 mA to 1 A Minimum load: 5 Vdc, 10 mA	223
	ME	N.C. Output		
	MF	Common (Speed agree)		
	M1	Multi-function digital output (During frequency output)	30 Vdc, 10 mA to 1 A; 250 Vac, 10 mA to 1 A Minimum load: 5 Vdc, 10 mA	
	M2			
	M3	Multi-function digital output (Through mode)		
M4				
Monitor Output	FM	Analog monitor output 1 (Output frequency)	-10 to +10 Vdc, or 0 to +10 Vdc	385
	AM	Analog monitor output 2 (Output current)		
	AC	Monitor common	0 V	–

<1> Refrain from assigning functions to digital relay outputs that involve frequent switching, as doing so may shorten relay performance life. Switching life is estimated at 200,000 times (assumes 1 A, resistive load).

## Serial Communication Terminals

Table 3.9 Control Circuit Terminals: Serial Communications

Type	No.	Signal Name	Function (Signal Level)	
MEMOBUS/Modbus Communication <I>	R+	Communications input (+)	MEMOBUS/Modbus communication: Use an RS-422 or RS-485 cable to connect the drive.	RS-422/RS-485 MEMOBUS/Modbus communication protocol 115.2 kbps (max.)
	R-	Communications input (-)		
	S+	Communications output (+)		
	S-	Communications output (-)		
	IG	Shield ground	0 V	

<1> Enable the termination resistor in the last drive in a MEMOBUS/Modbus network by setting DIP switch S2 to the ON position. Refer to the manual section on **Control I/O Connections** for more information.

#### ◆ Terminal Configuration

The control circuit terminals are arranged as shown in [Figure 3.29](#).

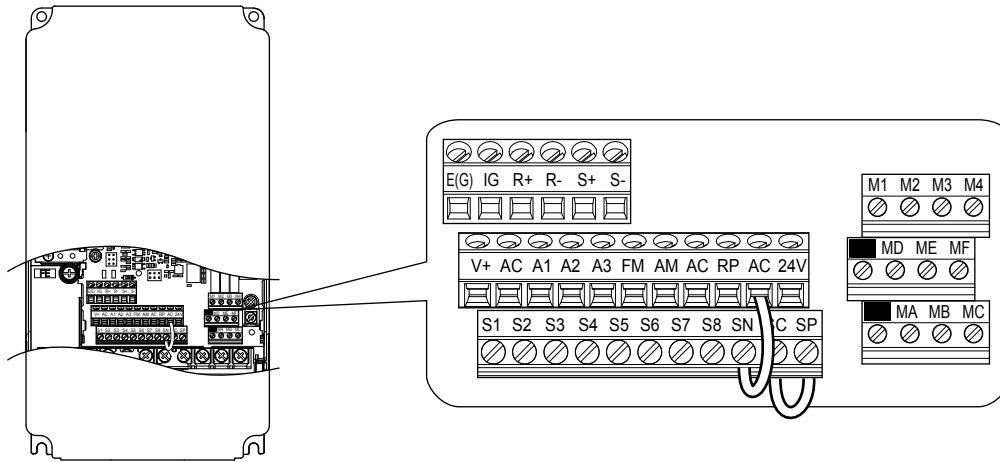

Figure 3.29 Control Circuit Terminal Arrangement

#### ■ Wire Size and Torque Specifications

Select appropriate wire type and gauges from [Table 3.10](#). For simpler and more reliable wiring, use crimp ferrules on the wire ends. Refer to [Table 3.11](#) for ferrule terminal types and sizes.

Table 3.10 Wire Gauges

Terminal	Screw Size	Tightening Torque N·m (lb. in)	Bare Wire Terminal		Ferrule-Type Terminal		Wire Type
			Applicable wire size mm <sup>2</sup> (AWG)	Recomm. wire size mm <sup>2</sup> (AWG)	Applicable wire size mm <sup>2</sup> (AWG)	Recomm. wire size mm <sup>2</sup> (AWG)	
S1-S8, SC, SN, SP	M3	0.5 to 0.6 (4.4 to 5.3)	Stranded wire: 0.2 to 1.0 (24 to 16) Solid wire: 0.2 to 1.5 (24 to 16)	0.75 (18)	0.25 to 0.5 (24 to 20)	0.5 (20)	Shielded wire, etc.
RP, V+, A1, A2, A3, AC, 24 V							
MA, MB, MC, MD, ME, MF							
M1-M4							
FM, AM, AC							
R+, R-, S+, S-, IG							

### ■ Ferrule-Type Wire Terminals

Yaskawa recommends using CRIMPFOX 6, a crimping tool manufactured by PHOENIX CONTACT, to prepare wire ends with insulated sleeves before connecting to the drive. See [Table 3.11](#) for dimensions.

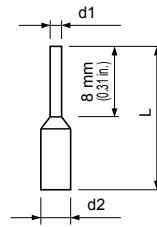

Figure 3.30 Ferrule Dimensions

Table 3.11 Ferrule Terminal Types and Sizes

Size mm <sup>2</sup> (AWG)	Type	L mm (in)	d1 mm (in)	d2 mm (in)	Manufacturer
0.25 (24)	AI 0.25-8YE	12.5 (0.49)	0.8 (0.03)	2.0 (0.08)	PHOENIX CONTACT
0.34 (22)	AI 0.34-8TQ	12.5 (0.49)	0.8 (0.03)	2.0 (0.08)	
0.5 (20)	AI 0.5-8WH AI 0.5-8OG	14.0 (0.55)	1.1 (0.04)	2.5 (0.10)	

### ◆ Wiring the Control Circuit Terminal

This section describes the proper procedures and preparations for wiring the control terminals.

**WARNING!** *Electrical Shock Hazard. Do not remove covers or touch the circuit boards while the power is on. Failure to comply could result in death or serious injury.*

**NOTICE:** *Separate control circuit wiring from main circuit wiring (terminals R/L1, S/L2, T/L3, B1, B2, U/T1, V/T2, W/T3, e, e1, e2) and other high-power lines. Improper wiring practices could result in drive malfunction due to electrical interference.*

**NOTICE:** *Separate wiring for digital output terminals MA, MB, MC, MD, ME, MF and M1 to M4 from wiring to other control circuit lines. Improper wiring practices could result in drive or equipment malfunction or nuisance trips.*

**NOTICE:** *Use a class 2 power supply when connecting to the control terminals. Improper application of peripheral devices could result in drive performance degradation due to improper power supply. Refer to NEC Article 725 Class 1, Class 2, and Class 3 Remote-Control, Signaling, and Power Limited Circuits for requirements concerning class 2 power supplies.*

**NOTICE:** *Insulate shields with tape or shrink tubing to prevent contact with other signal lines and equipment. Improper wiring practices could result in drive or equipment malfunction due to short circuit.*

**NOTICE:** *Connect the shield of shielded cable to the appropriate ground terminal. Improper equipment grounding could result in drive or equipment malfunction or nuisance trips.*

**NOTICE:** *Do not tighten screws beyond the specified tightening torque. Failure to comply may result in erroneous operation, damage to the terminal block, or cause a fire.*

**NOTICE:** *Use shielded twisted-pair cables as indicated to prevent operating faults. Improper wiring practices could result in drive or equipment malfunction due to electrical interference.*

Wire the control circuit only after terminals have been properly grounded and main circuit wiring is complete. [Refer to Terminal Board Wiring Guide on page 124](#) for details. Prepare the ends of the control circuit wiring as shown in [Figure 3.33](#). [Refer to Wire Gauges on page 122](#).

Connect control wires as shown in [Figure 3.31](#) and [Figure 3.32](#).

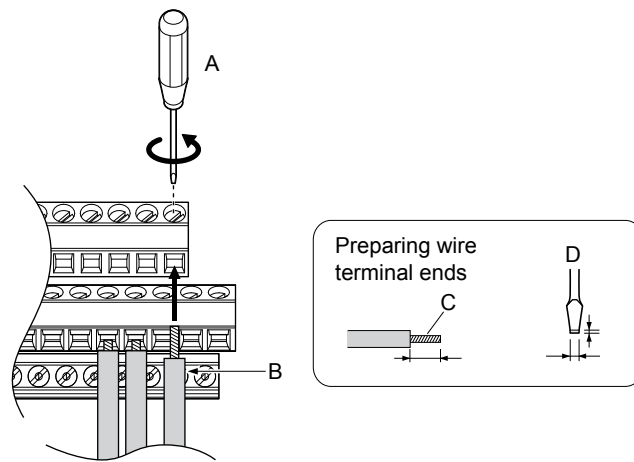

A – Loosen screw to insert wire.  
 B – Single wire or stranded wire

C – Avoid fraying wire strands when stripping insulation from wire. Strip length 5.5 mm.  
 D – Blade depth of 0.4 mm or less  
 Blade width of 2.5 mm or less

Figure 3.31 Terminal Board Wiring Guide

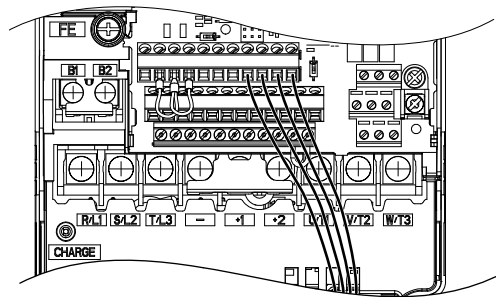
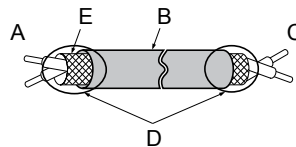

Figure 3.32 Terminal Board Location Inside the Drive

When setting the frequency by analog reference from an external potentiometer, use shielded twisted-pair wires (preparing wire ends as shown in [Figure 3.33](#)) and connect the shield to the ground terminal of the drive.



A – Drive side  
 B – Insulation  
 C – Control device side

D – Shield sheath (insulate with tape)  
 E – Shield

Figure 3.33 Preparing the Ends of Shielded Cables

**NOTICE:** The analog signal wiring between the drive and the operator station or peripheral equipment should not exceed 50 meters when using an analog signal from a remote source to supply the frequency reference. Failure to comply could result in poor system performance.

## 3.9 Control I/O Connections

### ◆ Sinking/Sourcing Mode for Digital Inputs

Use the wire jumper between terminals SC and SP or SC and SN to select between Sink mode, Source mode or external power supply for the digital inputs S1 to S8 as shown in [Table 3.12](#) (Default: Sink mode, internal power supply).

**NOTICE:** Do not short terminals SP and SN. Failure to comply will damage the drive.

**Table 3.12 Digital Input Sink/Source/External Power Supply Selection**

Mode	Drive Internal Power Supply (Terminals SN and SP)	External 24 Vdc Power Supply
Sinking Mode (NPN)		
Sourcing Mode (PNP)		

#### ◆ Terminals A1, A2, and A3 Input Signal Selection

Terminals A1, A2, and A3 can be used to input either a voltage or a current signal. Select the signal type using jumper S1 as explained in [Table 3.13](#). Set parameters H3-01, H3-05, and H3-09 accordingly as shown in [Table 3.14](#).

**Note:** If terminals A1 and A2 are both set for frequency bias (H3-02 = 0 and H3-10 = 0), both input values will be combined to create the frequency reference.

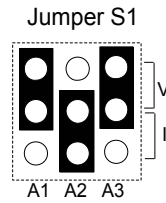

**Figure 3.34 Terminal A2 Set to Current Input; A1 and A3 Set to Voltage Input**

**Table 3.13 Jumper S1 Settings**

Setting	Description
V (top position)	Voltage input (-10 to +10 V or 0 to 10 V)
I (bottom position)	Current input (4 to 20 mA or 0 to 20 mA)

**Table 3.14 Voltage/Current Selection Parameter Details**

No.	Parameter Name	Description	Setting Range	Default Setting
H3-01	Terminal A1 signal level selection	Selects the signal level for terminal A1. 0: 0 to 10 Vdc 1: 0 to 10 Vdc Bipolar 2: 4 to 20 mA 3: 0 to 20 mA	0 to 3	0
H3-05	Terminal A3 signal level selection	Selects the signal level for terminal A3. 0: 0 to 10 Vdc 1: 0 to 10 Vdc Bipolar 2: 4 to 20 mA 3: 0 to 20 mA	0 to 3	0
H3-09	Terminal A2 signal level selection	Selects the signal level for terminal A2. 0: 0 to 10 Vdc 1: 0 to 10 Vdc Bipolar 2: 4 to 20 mA 3: 0 to 20 mA	0 to 3	2

■ Transducer Wiring

Simplex Pump System - Transducer Connection using Analog Input A2 (4 to 20 mA Mode)

A2 used for pressure transducer. Example of retrofit application where an external power supply is used.

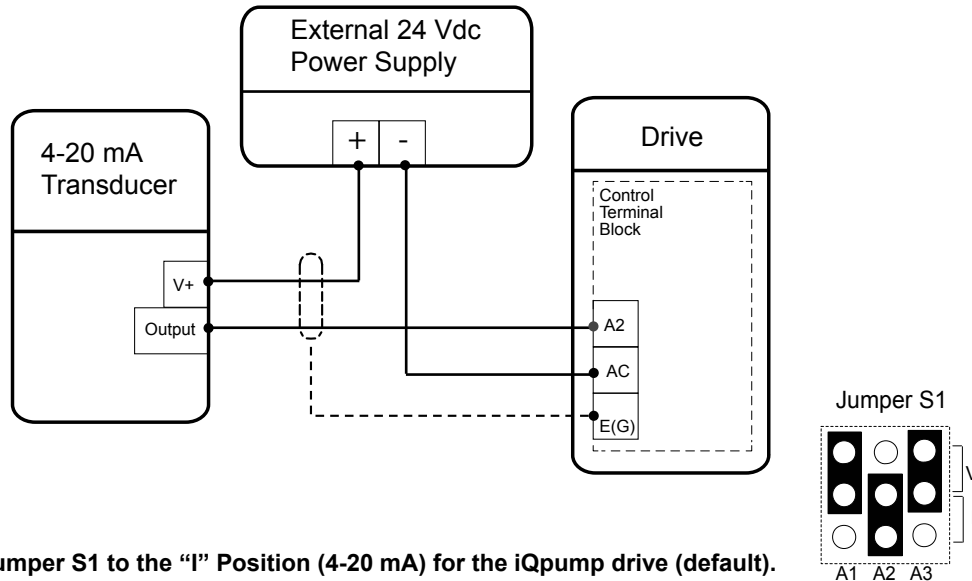

Set Jumper S1 to the "I" Position (4-20 mA) for the iQpump drive (default).

A2 used for pressure transducer. Example of new application where internal power supply is used

(2-Wire Transducer)

Example:  
Customer supplied  
pressure transducer  
feedback device

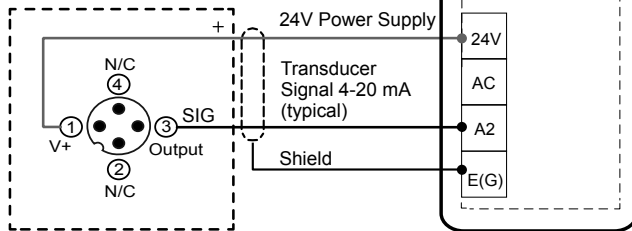

(3-Wire Transducer)

Example:  
Customer supplied  
pressure transducer  
feedback device

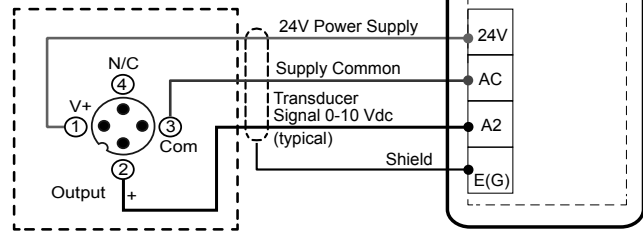

### 3.9 Control I/O Connections

#### Duplex System: Single Transducer Connection using Analog Input A2

A2 used for pressure transducer.

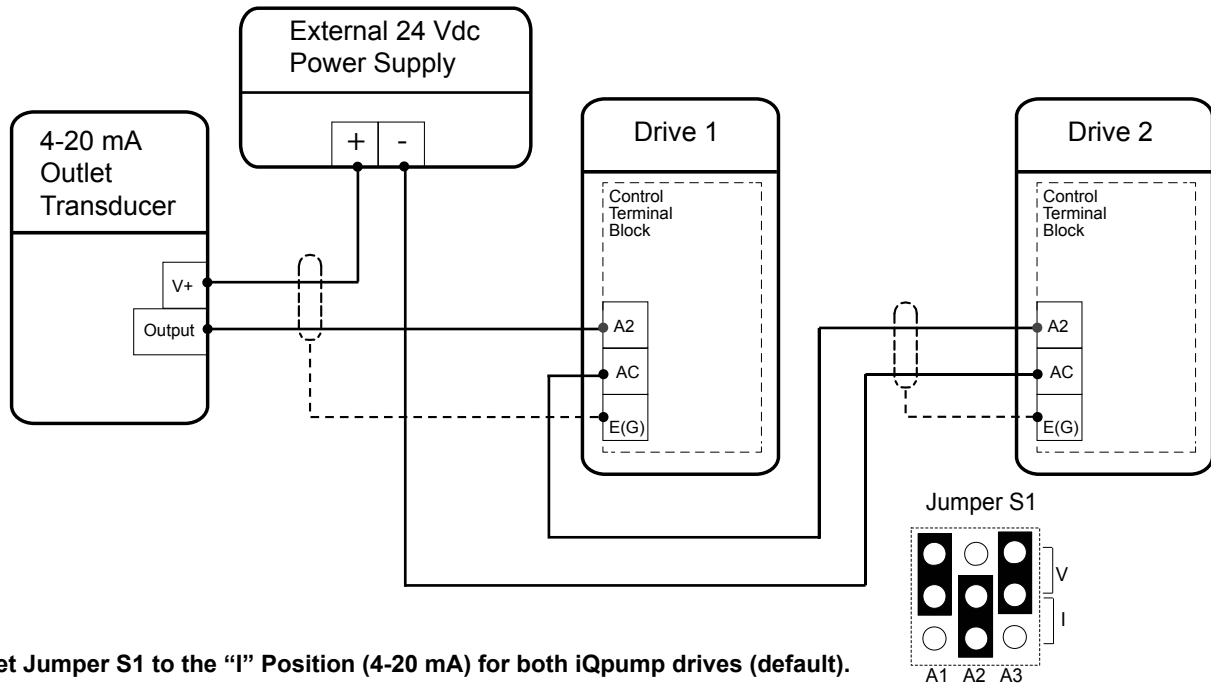

#### Triplex System: Transducer Connection using Analog Input A2

A2 used for water level or suction pressure transducer.

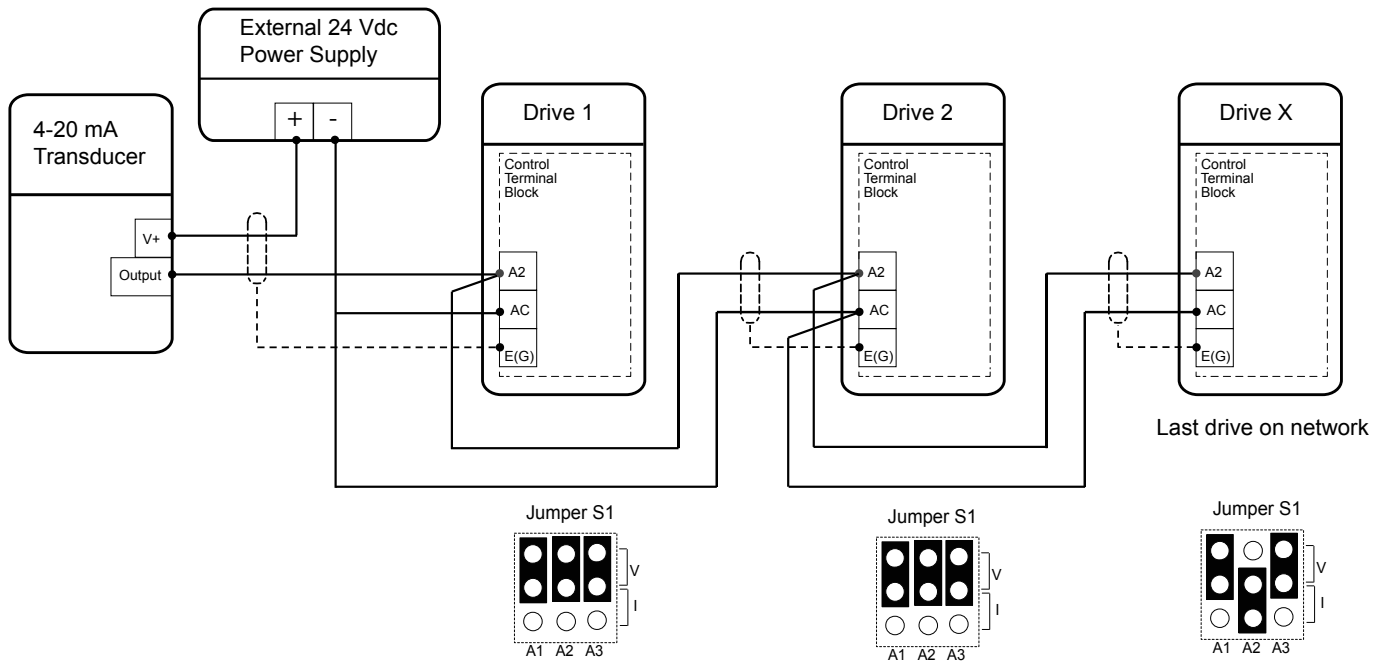



### ◆ Terminal AM/FM Signal Selection

The signal type for terminals AM and FM can be set to either voltage or current output using jumper S5 on the terminal board as explained in [Table 3.15](#). When changing the setting of jumper S5, parameters H4-07 and H4-08 must be set accordingly. The default selection is voltage output for both terminals.

Table 3.15 Jumper S5 Settings





Terminal	Voltage Output	Current Output
Terminal AM		
Terminal FM		

Table 3.16 Parameter H4-07 and H4-08 Details

No.	Parameter Name	Description	Setting Range	Default Setting
H4-07	Terminal FM signal level selection	0: 0 to 10 Vdc 1: -10 to 10 Vdc	0 to 2	0
H4-08	Terminal AM signal level selection	2: 4 to 20 mA		

## 3.10 Connect to a PC

This drive is equipped with a USB port (type-B).

The drive can connect to a USB port on a PC using a USB 2.0, AB-type cable (sold separately). After connecting the drive to a PC, Yaskawa DriveWizard iQpump software can be used to monitor drive performance and manage parameter settings. A complementary version of the DriveWizard iQpump software is available for download on our website at [iqpump.yaskawa.com](http://iqpump.yaskawa.com).

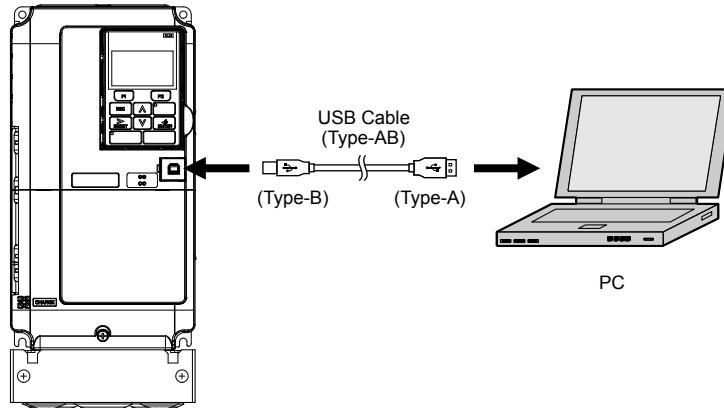

**Figure 3.35 Connecting to a PC (USB)**

# Start-Up Programming & Operation

---

This chapter explains startup procedures, HOA keypad functions, gives instructions on programming the drive for initial operation, and other important functions.

<b>4.1</b>	<b>DRIVE START-UP PREPARATION.....</b>	<b>132</b>
<b>4.2</b>	<b>POWERING UP THE DRIVE.....</b>	<b>134</b>
<b>4.3</b>	<b>APPLICATION SELECTION.....</b>	<b>138</b>
<b>4.4</b>	<b>USING THE HOA KEYPAD.....</b>	<b>139</b>
<b>4.5</b>	<b>PUMP APPLICATION PRESETS.....</b>	<b>146</b>
<b>4.6</b>	<b>IQPUMP PRESETS AND FUNCTIONS.....</b>	<b>150</b>
<b>4.7</b>	<b>BASIC IQPUMP SETUP AND APPLICATION PRESET PARAMETERS.....</b>	<b>210</b>
<b>4.8</b>	<b>TEST RUN WITH NO LOAD.....</b>	<b>246</b>
<b>4.9</b>	<b>TEST RUN WITH LOAD CONNECTED.....</b>	<b>247</b>

## 4.1 Drive Start-Up Preparation

### 4.1 Drive Start-Up Preparation

To provide the most reliable drive available and to avoid any extra costs related to loss or reduction of warranty coverage, an authorized Yaskawa service representative should complete this start-up procedure. Please complete the following checklist and maintain it in a secure location, as technical service personnel may request information from this checklist.

**Note:** Refer to *Powering Up the Drive on page 134* prior to powering up the drive for the first time.

Date: \_\_\_\_\_

#### Start-Up Person:

Company Name: \_\_\_\_\_ Start-Up Location: \_\_\_\_\_

Sales Order #: \_\_\_\_\_ Serial #: \_\_\_\_\_

Printed Name: \_\_\_\_\_ Drive Location: \_\_\_\_\_

Phone #: \_\_\_\_\_ Signature: \_\_\_\_\_

#### Owner's Representative:

Printed Name: \_\_\_\_\_ Phone #: \_\_\_\_\_

Company: \_\_\_\_\_ Signature: \_\_\_\_\_

### ◆ Start-Up Checklist

<input checked="" type="checkbox"/>	No.	Item
<input type="checkbox"/>	1	The drive is thoroughly tested at the factory. The start up person should verify that the drive is free of shipping and installation damage. Shipping damage is not covered by the Yaskawa warranty. Claims must be filed with the shipping company as soon as possible for any potential recovery via insurance.
<input type="checkbox"/>	2	Review the iQpump1000 Quick Start Procedure shipped with the drive.
<input type="checkbox"/>	3	Verify that the model number and voltage ratings in the purchase order match the nameplate data for each unit.
<input type="checkbox"/>	4	The location of the drive is important to achieve proper performance and normal operating life. <i>Refer to Installation Environment on page 36</i> for details.
<input type="checkbox"/>	5	Ensure the drive is on a vertical surface with adequate space for air circulation. <i>Refer to Correct Installation Spacing on page 37</i> for proper spacing.
<input type="checkbox"/>	6	Verify that the proper branch circuit protection is installed in front of the drive. Refer to Factory Recommended Branch Circuit Protection in this document for proper input fuse or circuit breaker sizing.
<input type="checkbox"/>	7	<b>NOTICE:</b> Separate control circuit wiring from main circuit wiring (terminals R/L1, S/L2, T/L3, B1, B2, U/T1, V/T2, W/T3, -, +1, +2) and other high-power lines. Improper wiring practices could result in drive malfunction due to electrical interference.
<input type="checkbox"/>	8	<b>NOTICE:</b> Insulate shields with tape or shrink tubing to prevent contact with other signal lines and equipment. Improper wiring practices could result in drive or equipment malfunction due to short circuit.
<input type="checkbox"/>	9	<b>WARNING!</b> Electrical Shock Hazard. Do not connect the AC power line to the output terminals of the drive. Failure to comply could result in death or serious injury by fire as a result of drive damage from line voltage application to output terminals.
<input type="checkbox"/>	10	<b>NOTICE:</b> Do not connect phase-advancing capacitors or LC/RC noise filters to the output circuits. Failure to comply could result in damage to the drive, phase-advancing capacitors, LC/RC noise filters or ground fault circuit interrupters.
<input type="checkbox"/>	11	Use crimp insulated terminals or insulated shrink tubing for wiring connections. Wires should have a continuous maximum allowable temperature of 75 °C 600 Vac UL-approved vinyl-sheathed insulation. Consider the amount of voltage drop when selecting wire gauges. Increase the wire gauge when the voltage drop is greater than 2% of motor rated voltage. Ensure the wire gauge is suitable for the terminal block. Use the following formula to calculate the amount of voltage drop: Line drop voltage (V) = 3 × wire resistance (Ω/km) × wire length (m) × current (A) × 10 <sup>-3</sup>
<input type="checkbox"/>	12	If the cable between the drive and motor exceeds 50 m (164 ft.), adjust the carrier frequency set C6-02 accordingly.
<input type="checkbox"/>	13	Determine proper wire size for power and motor leads.

<input checked="" type="checkbox"/>	No.	Item
<input type="checkbox"/>	14	<p><b>WARNING!</b> Always ground the ground terminal. (200 V Class: Ground to 100 <math>\Omega</math> or less, 400 V Class: Ground to 10 <math>\Omega</math> or less). Improper equipment grounding could result in death or serious injury by contacting ungrounded electrical equipment.</p> <p>When using multiple drives, ground each drive directly or daisy-chain to the ground pole(s). DO NOT FORM A LOOP WITH THE GROUND LEADS. <i>Refer to Multiple Drive Wiring on page 118.</i></p>
<input type="checkbox"/>	15	Review terminal functions of signal and control circuits.
<input type="checkbox"/>	16	Verify if any customer safety devices are required (e.g. External Pump Fault).
<input type="checkbox"/>	17	Record the following motor nameplate information: Voltage: _____ Motor Rated Amps: _____
<input type="checkbox"/>	18	Verify that the commercial power supply is within the rated drive input voltage: Power Supply: _____ Vac Drive Input Voltage: _____ Vac
<input type="checkbox"/>	19	Determine whether three-phase input power or single-phase input power is to be used. Refer to the iQpump1000 Quick Start Guide for additional application information if using single-phase.
<input type="checkbox"/>	20	Verify that the leads in the three-phase electric motor conduit box are configured for the proper voltage.
<input type="checkbox"/>	21	Ensure Motor Rated Current is less than or equal to drive output amps. If multiple motors are being used, make sure that the Motor Rated Current sum is less than or equal to drive output amp rating. Please note that if multiple motors are being operated from one drive, each motor must have its own overload and short circuit protection.
<input type="checkbox"/>	22	Wire all necessary power leads to the drive. <b>DO NOT CONNECT MOTOR TO DRIVE AT THIS TIME.</b>
<input type="checkbox"/>	23	Wire all necessary <b>ground</b> wires to the drive.
<input type="checkbox"/>	24	Wire all necessary <b>control</b> wires to the drive.
<input type="checkbox"/>	25	Ensure that the power leads are connected to the R/L1, S/L2 and T/L3 terminals in the drive. Confirm single-phase input or three-phase input wiring.
<input type="checkbox"/>	26	Tighten all of the three-phase power and ground connections. Please check that all control and signal terminations are tight.
<input type="checkbox"/>	27	Inspect the control circuit connections (including the shield) and determine if a motor safety circuit is connected. If normally closed, these contacts may be wired in series with the RUN command contacts, which are between terminals S1 and SN of the drive. No special programming is required. Alternately, these contacts could be wired between terminals S3 and SN as External Fault Inputs, and may be either normally closed or normally open contacts.
<input type="checkbox"/>	28	Record any other connections to the drive to determine if special programming is required for the following: Multi-function Inputs Multi-function Outputs Multi-function Digital Inputs Multi-function Analog Outputs Network Communications

# 4.2 Powering Up the Drive

Review the following table before applying power.

Item to Check	Description
Power supply voltage	200 V class: Three-phase/Single-phase 200 to 240 Vac 50/60 Hz 400 V class: Three-phase/Single-phase 380 to 480 Vac 50/60 Hz 600 V class: Three-phase/Single-phase 500 to 600 Vac 50/60 Hz
	Properly wire the power supply input terminals (R/L1, S/L2, T/L3). </>
	Check for proper grounding of drive and motor.
Drive output terminals and motor terminals	Properly wire drive output terminals U/T1, V/T2, and W/T3 with motor terminals U, V, and W.
Control circuit terminals	Check control circuit terminal connections.
Drive control terminal status	Open all control circuit terminals (off).
Status of the load and connected machinery	Decouple the motor from the load.

<1> Confirm the following when connecting models 4A0930 and 4A1200: Remove the jumpers on R1/L11, S1/L21, and T1/L31 when using 12-phase rectification. [Refer to 12-Phase Rectification on page 97](#) for details. When operating without 12-phase rectification, properly wire terminals R1/L11, S1/L21, and T1/L31 in addition to terminals R/L1, S/L2, and T/L3.

### ◆ Setting the Real Time Clock

The time and date must be set when a new HOA keypad is plugged in and the drive is powered up. The HOA keypad will display the time and date setup screen for 30 seconds. If a button is not pressed during this time, the display will clear and a “Clock Not Set” alarm will flash. Pressing the F2 (Data) key will display the setting screen again.

#### ■ Feedback Loss Wire Break Alarm

If there is no sensor wired to the drive, a “Feedback Loss – Wire Break” alarm will flash on the display. Providing the proper feedback device signal will clear the Feedback Loss alarm.

The drive requires a feedback device (e.g., pressure transducer, flow meter, etc.) to perform automatic system regulation. Any analog 0~10 V or 4-20 mA feedback device can be used in combination with the drive.

**Note:** The factory default setting for the drive is 4~20 mA feedback device connected to analog input A2.

#### ■ Real Time Clock Setting Display

**Note:** Setting the Real-Time Clock will clear a “Clock Not Set” alarm.

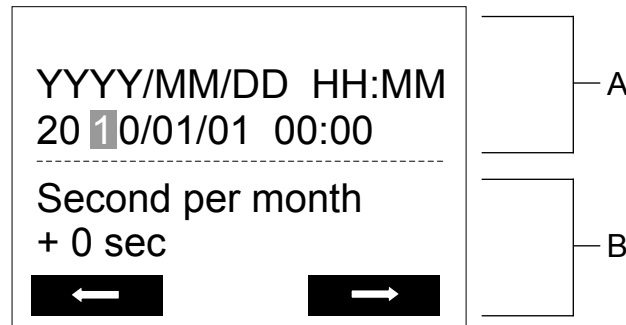

A – Real Time Clock Setting Display  
Set in 24-Hour Clock Time

B – Gain/Loss Adjustment Display

Figure 4.1 Real Time Clock Adjustment Display

Display	Description
YYYY	Set the year with the last two digits.
MM	Set the month with two digits.
DD	Set the day with two digits.
HH:MM	Set the hours and minutes, with two digits for each. <b>Note:</b> Set in 24-hour clock time. After initial setup, the time will display in 12-hour clock time.

Display	Description
Second per month	Set the gain or loss in seconds per month. <b>Note:</b> This does not need to be set for the RTC to function properly.

**Moving the Cursor**

Pressing the F2 key or the RESET key will move the cursor to the digit on the right. Pressing the F1 key will move the cursor to the left.

**Changing Settings**

- **Changing YYYY/MM/DD HH:MM:** Pressing the up arrow key will increase the number selected by the cursor from 0 to 9. Pressing the down arrow key will decrease the number selected by the cursor from 0 to 9.
- **Setting the Seconds per Month:** *This setting does not need to be adjusted.* Pressing the up arrow key will increase the number selected by the cursor from -504 to +488 in increments of 8. Pressing the down arrow key will decrease the number selected by the cursor from -504 to +488 in increments of 8.

The feature is used to keep the RTC in sync with an external device clock, like a PLC or BAS system, and will adjust the clock by a set amount of seconds every month.

**Real-Time Clock Setting at Initial Power-up of a New Drive**

Setting the Real-time clock is required at power-up of a new HOA operator or after digital operator battery replacement.

Table 4.1 illustrates how to set the Real-Time Clock at initial power-up of a new drive.

**Table 4.1 Clock Adjustment Procedure at Power-up of a New Drive**

Procedure		Display
1	Turn the power on. The Real Time Clock Adjustment Display will appear. Use the right arrow key to select the desired digit, then set the correct date and 24-hour clock time using the up and down arrow keys.	<p>The display shows: ALM, YYYY/MM/DD HH:MM, 2010/01/01 00:00, Second per month, + 0 sec. Navigation arrows are visible.</p>
2	After entering the Real-Time Clock data, press the ENTER key to save the changes. The display will indicate “Entry Accepted” and return to the initial display in step 3 and the alarm LED will be OFF.	<p>The display shows: ALM, Entry accepted.</p>
3	Initial display.	<p>The display shows: - MODE - DRV Rdy, Auto Setpoint, U5-99= 0.0PSI, U1-02= 0.00Hz LSEQ, U1-91= 0.0PSI LREF, &lt;-MONITOR-&gt;</p>

**Manual Clock Adjustment by Setting o4-17 to 1**

The following actions are possible in the Clock Adjustment Mode:

- Set the current time
- Check the time set to the drive Real-Time Clock

Table 4.2 illustrates how to set the Real-Time Clock manually.

## 4.2 Powering Up the Drive

Table 4.2 Manual Clock Adjustment Procedure by Setting o4-17 to 1

Procedure		Display
1	The “Clock Not Set” display will appear if the Real-Time Clock data is not entered within 30 seconds of power-up of a drive with an HOA operator that has not yet been set.	
2	Use the up and down arrow keys to scroll through display menu until the screen shows “Programming”.	
3	Press the ENTER key to enter select the parameter setting mode.	
4	Use the up and down arrow keys to scroll through display menu until parameter o4-17 appears.	
5	Press the ENTER key until “0” flashes.	
6	Press the up arrow key so that the display changes to “1”.	
7	Press the ENTER key and the time setting screen will appear. Use the right arrow key to select the desired digit, then set the correct date and time using the up and down arrow keys.	
8	After entering the correct time, press the ENTER key to save the changes. The display will return to the display shown in step 5 and the alarm LED will be OFF.	

### ■ o4-17: Real-Time Clock Setting (Resetting RTC to Factory Default)

No. (Addr. Hex)	Name	Description	Values
o4-17 (3100)	Set/Reset Real-time Clock	Sets the current date and time for the Real-Time Clock. 0: — — No Setting 1: Real-Time Clock Set 2: Real-Time Clock Reset	Default: 0 Range: 0 to 2



**Setting 0: — —**

No Setting (Default)

**Setting 1: Set**

The digital operator will show the Clock Adjustment display. In Clock Adjustment Mode the user can adjust the Real-Time Clock.

**Setting 2: Reset**

The Real-Time Clock data is cleared. A Clock Not Set alarm will occur until o4-17 is set to 1 and the Real-Time Clock is set.

### 4.3 Application Selection

Application Presets are available to facilitate drive setup for commonly used applications. Selecting one of these Application Presets automatically assigns functions to the input and output terminals and sets a predefined group of parameters to values appropriate for the selected application.

In addition, the parameters most likely to be changed are assigned to the group of User Parameters, A2-01 through A2-16. User Parameters are part of the Setup Group, which provides quicker access by eliminating the need to scroll through multiple menus.

**Note:** Entering a value to A1-03 to enable an Application Preset will fix that value to the parameter. The value cannot be changed without first setting A1-03 to 2220 or 3330 to initialize the drive.

**WARNING!** *Sudden Movement Hazard. Confirm the drive I/O signals and external sequence before performing a test run. Setting parameter A1-03 may automatically change the I/O terminal function from the default setting. Failure to comply may result in death or serious injury.*

No.	Parameter Name	Settings	Default
A1-03	Initialize Parameters	0: No initialization (default) 1110: User initialize (parameter values must be stored using parameter o2-03) 2220: 2-Wire initialize 3330: 3-Wire initialize 5550: Terminal/Control initialize 6008: Pressure control 6009: Pump down level 6010: Geothermal mode 6011: VTC pressure control <1> 6012: Pivot Panel VTC <1> 6013: Advanced Pressure Control 6014: Pivot Panel Submersible <2> 7770: General purpose 7771: Submersible motor control	0
A1-06	Application Presets (monitor only)	0: Pressure Control 1: General Purpose 2: Sub Mtr GP Oper 5: General Ext HOA <1> 6: General HOA Keys <1> 8: Pressure Control 9: Pump Down Level 10: Geothermal Mode 11: VTC Pressure Control 12: Pivot Panel VTC <1> 13: Advanced Pressure Control <1> 14: Pivot Panel Submersible <2>	0

<1> Available in drive software versions PRG: 8552 and later. Not available in drive models 4A0930 and 4A1200.

<2> Available in drive software versions PRG: 8553 and later. Not available in drive models 4A0930 and 4A1200.

## 4.4 Using the HOA Keypad

Use the HOA keypad to enter OFF commands, switch AUTO or HAND Mode, change parameters, and display data including fault and alarm information.

### ◆ HOA Keypad Keys and Displays

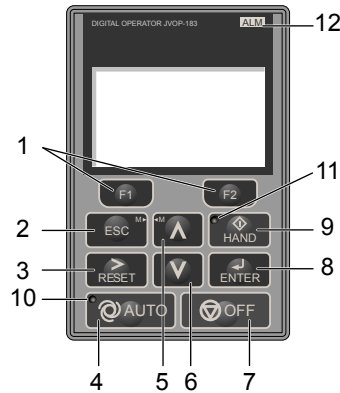

Figure 4.2 Keys and Displays on the HOA Keypad

No.	Display	Name	Function
1		Function Key (F1, F2)	The functions assigned to F1 and F2 vary depending on the currently displayed menu. The name of each function appears in the lower half of the display window.
2		ESC Key	<ul style="list-style-type: none"> <li>Returns to the previous display.</li> <li>Moves the cursor one space to the left.</li> <li>Pressing and holding this button will return to the Frequency Reference display.</li> </ul>
3		RESET Key	<ul style="list-style-type: none"> <li>Moves the cursor to the right.</li> <li>Resets the drive to clear a fault situation.</li> </ul>
4		AUTO Key	Selects the source of Run command and frequency reference. <ul style="list-style-type: none"> <li>Set the drive to AUTO mode.</li> <li>Run command input source depends on b1-02.</li> <li>Frequency reference input source depends on b1-01.</li> </ul>
5		Up Arrow Key	Scrolls up to display the next item, selects parameter numbers, and increments setting values.
6		Down Arrow Key	Scrolls down to display the previous item, selects parameter numbers, and decrements setting values.
7		OFF Key	Follows the stopping method set in b1-03 to stop drive operation. <p><b>Note:</b> The OFF key is DISABLED during Emergency Override.</p>
8		ENTER Key	<ul style="list-style-type: none"> <li>Enters parameter values and settings.</li> <li>Selects a menu item to move between displays.</li> </ul>
9		HAND Key	The drive runs at a selectable frequency reference source as set by P5-01. <ul style="list-style-type: none"> <li>Set the drive to HAND mode.</li> <li>When P5-03 is set to 1, HAND and AUTO mode can be switched while the drive is running.</li> </ul>
10		AUTO Light	Lit while the drive is in AUTO mode. Refer to page 141 for details.
11		HAND Light	Lit while the drive is in HAND mode. Refer to page 141 for details.
12		ALM LED Light	<i>Refer to ALARM (ALM) LED Displays on page 141.</i>

◆ LCD Display

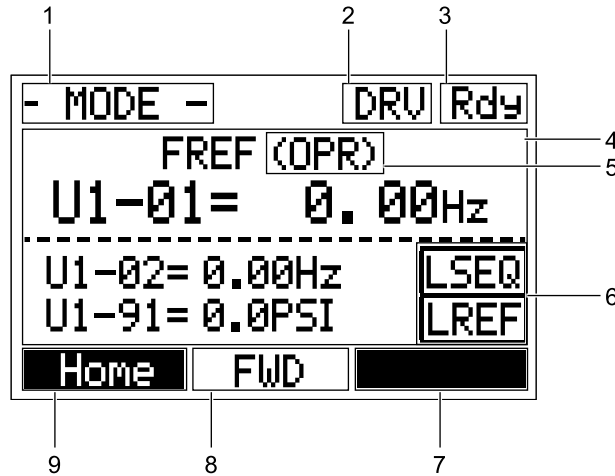







Figure 4.3 LCD Display

Table 4.3 Display and Contents

No.	Name	Display	Content
1	Operation Mode Menus	MODE	Displayed when in Mode Selection.
		QMONI: Use F1/F2	Instructions to access the Quick Monitors.
		MENU: Use UP/DWN	Instructions to access the next menu item.
		MONITR	Displayed when in Monitor Mode.
		VERIFY	Indicates the Verify Menu.
		PRMSET	Displayed when in Parameter Setting Mode.
		A.TUNE	Displayed during Auto-Tuning.
2	Mode Display Area	DRV	Displayed when in Drive Mode.
		PRG	Displayed when in Programming Mode.
3	Ready	Rdy	Indicates the drive is ready to run.
4	Data Display	—	Displays specific data and operation data.
5	Frequency Reference Assignment <F>	OPR	Displayed when the frequency reference is assigned to the HOA keypad.
		COM	Displayed when the frequency reference is assigned to the MEMOBUS/Modbus Communication Inputs of the drive.
		OP	Displayed when the frequency reference is assigned to option card connected to the drive.
		AI	Displayed when the function reference is assigned to an analog input.
		OFF	Displayed when HAND mode is OFF.
6	LOCAL/REMOTE Display <L>	RSEQ	Displayed when the Run command is supplied from a remote source. <b>Note:</b> This display will blink when b1-02 is set to 1 (Digital Inputs).
		LSEQ	Displayed when the Run command is supplied from the HOA keypad.
		RREF	Displayed when the Run command is supplied from a remote source. <b>Note:</b> This display will blink when b1-01 is set to 1 (Analog Inputs).
		LREF	Displayed when the Run command is supplied from the HOA keypad.
7	Function Key 2 (F2)	<-MONITOR->	Pressing  displays the next Quick Monitor.
		DATA	Pressing  scrolls to the next display.
		→	Pressing  scrolls the cursor to the right.
		RESET	Pressing  resets the existing drive fault error.
		Monitor	Pressing  switches Monitor mode.



No.	Name	Display	Content
8	FWD/REV	FWD	Indicates forward motor operation.
		REV	Indicates reverse motor operation.
9	Function Key 1 (F1)	<-MONITOR->	Pressing  displays the next Quick Monitor.
		←	Pressing  scrolls the cursor to the left.
		Home	Pressing  returns to the top menu (Frequency Reference).
		ESC	Pressing  returns to the previous display.
		Monitor	Pressing  switches Monitor mode.

<1> Displayed when in Frequency Reference Mode.

<2> Displayed when in Frequency Reference Mode and Monitor Mode.



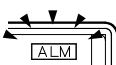















### ◆ ALARM (ALM) LED Displays

Table 4.4 ALARM (ALM) LED Status and Contents

State	Content	Display
Illuminated	When the drive detects an alarm or error.	
Flashing	<ul style="list-style-type: none"> <li>When an alarm occurs.</li> <li>When an oPE is detected.</li> <li>When a fault or error occurs during Auto-Tuning.</li> </ul>	
Off	Normal operation (no fault or alarm).	

### ◆ AUTO LED and HAND LED Indications

Table 4.5 AUTO LED and HAND LED Indications

AUTO LED	HAND LED	State
 Off	 Off	OFF mode
 Off	 On solid	HAND mode (Also during DC injection braking)
 Off	 Long blink (50% duty)	HAND mode when the Frequency Reference is 0 and/or decelerating in HAND mode, or during PI Sleep or Snooze.
 On solid	 Off	Running in AUTO mode (Also during DC injection braking)
 Off	 Short blink (15% duty)	HAND mode, Ready, No Run command input. <b>Note:</b> Short Blink for Legacy Operation Mode (S5-04 = 0).
 Off	 Double blink	HAND mode, cycle the Run command.
 Long blink (50% duty)	 Off	Running in AUTO mode when the Frequency Reference is 0 and/or decelerating in AUTO mode, or during PI Sleep or Snooze.
 Short blink (15% duty)	 Off	AUTO mode, Ready, No run command input.
 Double blink	 Off	AUTO mode, stopped by a Fast- Stop from a Multi-Function Digital Input.

## 4.4 Using the HOA Keypad

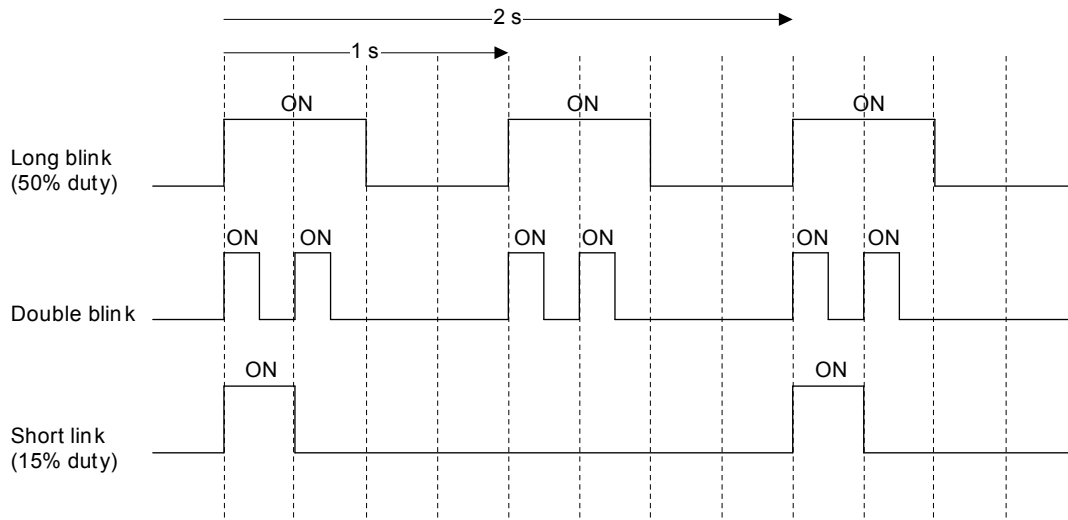

**Figure 4.4 AUTO LED and HAND LED Timing Status**

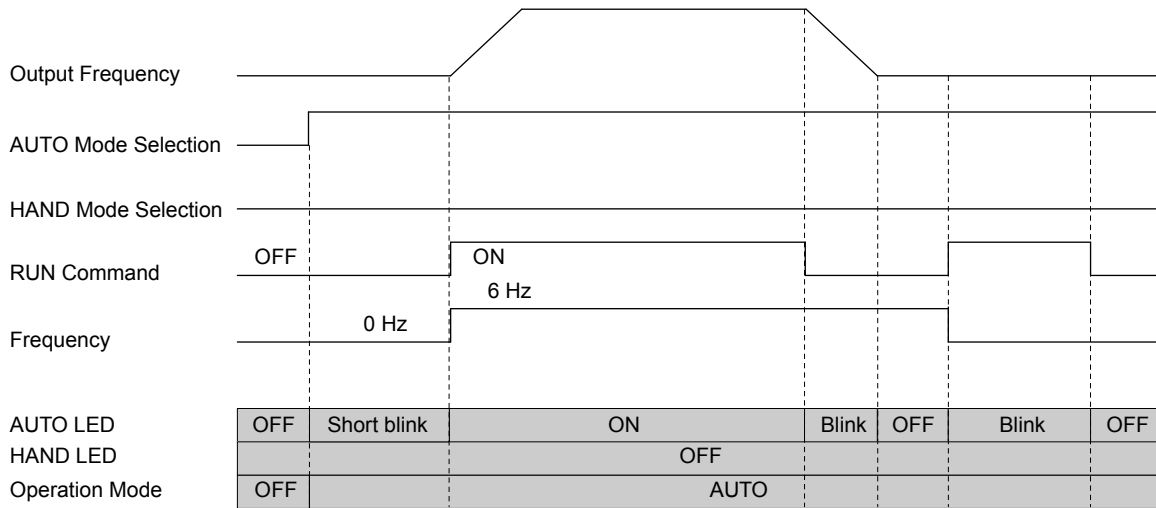

**Figure 4.5 LEDs and Drive Operation in AUTO and HAND Modes**

◆ Menu Structure for HOA Keypad

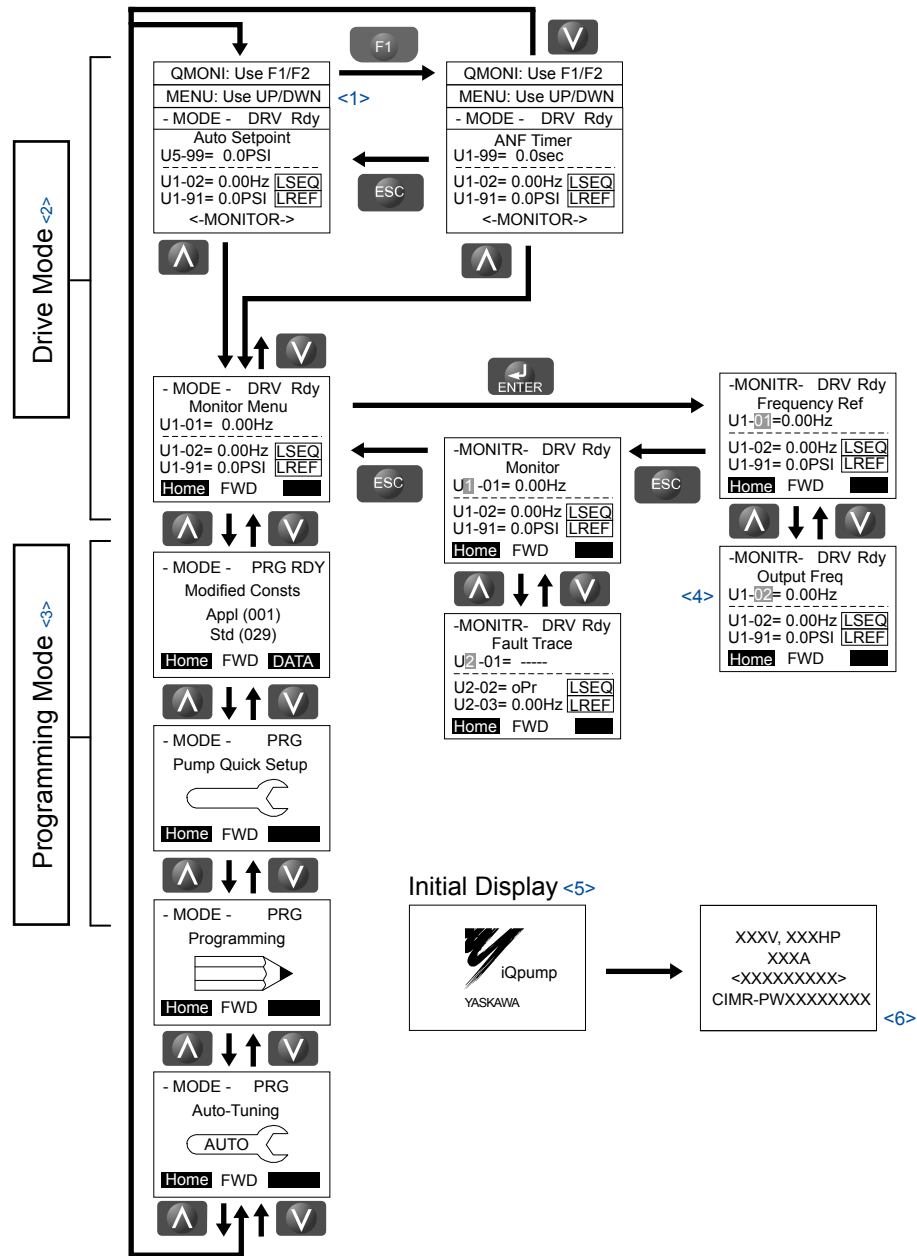

Figure 4.6 HOA Keypad Menu and Screen Structure











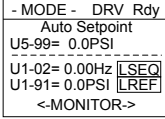

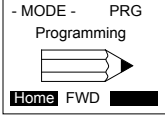

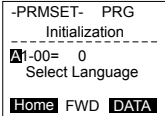

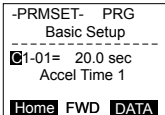

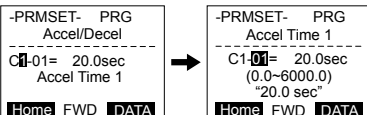
- <1> The display cycles between these three displays on the initial startup screen and the Quick Monitor screens.
- <2> Pressing “AUTO” or “HAND” will start the motor.
- <3> Drive cannot operate motor.
- <4> Flashing characters are shown with white letters on gray background. (Example: 0 )
- <5> The Frequency Reference appears after the initial display that shows the product name.
- <6> The information that appears on the display will vary depending on the drive model.

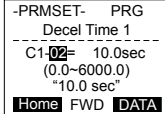
## 4.4 Using the HOA Keypad

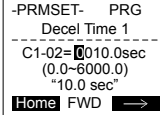
### ◆ Changing Parameter Settings or Values

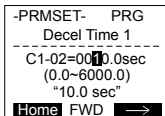
This example explains changing C1-02 (Deceleration Time 1) from 10.0 seconds (default) to 20.0 seconds.

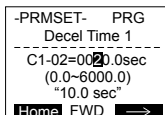
**Note:** During serial communication writing, if a parameter change is also attempted via the HOA keypad, a “BUSY - WRITE PROTECTED” message will display. Parameter change will not be possible from the HOA keypad until an Enter command is received via the serial communication to finish the serial writing process.

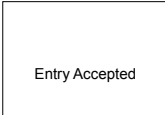
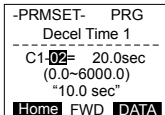
Step		Display/Result
1.	Turn on the power to the drive. The initial display appears.	
2.	Press  or  until the Parameter Setting Mode screen appears.	
3.	Press  to enter the parameter menu tree.	
4.	Press  or  to select the C parameter group.	
5.	Press  two times.	
6.	Press  or  to select parameter C1-02.	
7.	Press  to view the current setting value (10.0 s). The leftmost digit flashes.	
8.	Press  or  until the desired number is selected. “1” flashes.	
9.	Press  and enter 0020.0.	
10.	Press  to confirm the change.	
11.	The display automatically returns to the screen shown in Step 6.	



Step			Display/Result
12.	Press  as many times as necessary to return to the initial display.	➔	<pre> - MODE - DRV Rdy Auto Setpoint U5-99= 0.0PSI ----- U1-02= 0.00Hz [LSEQ] U1-91= 0.0PSI [LREF] &lt;-MONITOR-&gt;                     </pre>

# 4.5 Pump Application Presets

The following sections list the parameters affected by the different Application Presets.

**Note:** Setting A1-03 to 6011 or 6012 changes the Quick Start and Preset parameters (tables below) and also changes HAND Mode so that it is no longer lower-limited by the minimum pump frequency or the thrust frequency. Also, the default for P1-06 when in RPM mode is 1800 RPM instead of 2400 RPM.

### ◆ Modified Parameters Depending on A1-03 Setting

The following tables show the parameters that are set depending on the A1-03 initialization:

A1-03 = 6009 (A1-06 = 9) Pump Down Level		A1-03 = 6010 (A1-06 = 10) Geothermal Mode		A1-03 = 6011 (A1-06 = 11) VTC Pressure Control		A1-03 = 6012 (A1-06 = 12) Pivot Panel VTC	
Parameter	Value	Parameter	Value	Parameter	Value	Parameter	Value
A1-02	0	b1-01	5	A1-02	0	A1-02	0
b5-09	1	b5-01	0	b1-03	1	b1-02	1
b5-39	2	H3-10	21	b5-03	5	b1-03	0
P1-02	6	o1-08	180	C1-01	15.0 s	b5-03	5.0 s
P2-01	2			C1-02	15.0 s	C1-01	20.0 s
P2-23	0.00%			E1-04	65.0 Hz	C1-02	20.0 s
P9-18	0.00%			E2-04	4	E1-04	65.0 Hz
				L2-01	0	E2-04	4
				L5-01	0	L2-01	0
				P1-03	100.0 PSI	L5-01	0
				P1-06	35.0 Hz	L5-04	300.0 s
				P2-03	15 s	P1-03	210.0 PSI <1>
				P2-23	0.00%	P1-06	35.0 Hz
				P3-50	35.0 Hz	P1-11 <2>	210.0 PSI
				P3-60	35.0 Hz	P1-40	60.0 Hz
				P3-70	35.0 Hz	P2-03	15 s
				P4-12	0.0 Hz	P2-23	0.00%
				P5-02	6.0 Hz	P4-12	0.0 Hz
				Q5-03	40.0 PSI	P5-01	0
				Q5-06	50.0 PSI	P5-02	6.0 Hz
				Q5-09	20.0 PSI		
				Q5-10	5.0 min		
				Q5-11	2		
				Q5-16	1		
				Q5-17	3.0 s		
				H2-01	80H		
				H2-02	81H		
				H2-03	82H		
				P1-40	60.0 Hz		
				P3-01	2		
				P3-04	5.0 PSI		
				P3-06	5.0 Hz		
				P3-07	7.0 s		
				P3-10	2.0 PSI		

<1> Default is 100.0 PSI in drive software versions PRG: 8553 and earlier.

<2> Available in drive software versions PRG: 8554 and later.

A1-03 = 6013 (A1-06 = 13) Advanced Pressure Control		A1-03 = 6014 (A1-06 = 14) Pivot Panel Submersible		A1-03 = 7770 (A1-06 = 1) General Purpose		A1-03 = 7771 (A1-06 = 2) Sub Mtr GP Oper	
Parameter	Value	Parameter	Value	Parameter	Value	Parameter	Value
A1-02	0	A1-02	0	b1-01	1	A1-02	0
		b1-02	1	b1-02	1	b5-01	0
		b1-03	0	b5-01	0	H1-06	4
		b5-03	5.0 s	C1-01	25.0 s	H2-01	0
		C1-01	20.0 s	C1-02	25.0 s	H2-02	A
		C1-02	20.0 s	H1-06	4	o1-06	0
		E1-04	65.0 Hz	H1-07	F	P1-05	0 s
		L2-01	0	H2-01	0	d1-01	40.00 Hz
		L5-01	0	H2-02	A		
		L5-04	300.0 s	H3-10	2		
		P1-03	200.0 PSI <1>	L5-01	0		
		P1-11 <2>	210.0 PSI	L5-04	180.0 s		
		P1-40	60.0 Hz	o1-06	0		
		P2-03	15 s	P1-05	0 sec		
		P2-23	0.00%	P1-06	0.0 Hz		
		P5-01	0	P4-12	0.0 Hz		
		P5-02	6.0 Hz	P4-17	0.0 min		
				P5-02	0.0 Hz		

<1> Default is 100.0 PSI in drive software versions PRG: 8553 and earlier.

<2> Available in drive software versions PRG: 8554 and later.

## 4.5 Pump Application Presets

### ◆ Pump Quick Setup Menu Depending on A1-06 Setting

The following table shows which parameters are shown on the Pump Quick Setting menu depending on the A1-06 selection:

A1-03 = 6008 (A1-06 = 8) Pressure Control	A1-03 = 6009 (A1-06 = 9) Pump Down Level	A1-03 = 6010 (A1-06 = 10) Geothermal Mode	A1-03 = 6011 (A1-06 = 11) VTC Pressure Ctl	A1-03 = 6012 (A1-06 = 12) Pivot Panel VTC	A1-03 = 6013 (A1-06 = 13) Adv PressureCtrl	A1-03 = 6014 (A1-06 = 14) Pivot Panel Submersible	A1-03 = 7770 (A1-06 = 1) General Purpose	A1-03 = 7771 (A1-06 = 2) Sub Mtr GP Oper
E2-01	E2-01	b1-02	E2-01	E2-01	E2-01	E2-01	b1-01	E2-01
E2-04	E2-04	E2-01	b1-02	b1-02	E2-20 <1>	b1-02	b1-02	E2-04
P1-03	P1-02	E2-04	b1-03	b1-03	P1-03	b1-03	C1-01	d1-01
Q1-01	P1-03	P1-06	b1-11	b1-11	Q1-01	b1-11	C1-02	P1-06
P1-04	Q1-01	Q2-01	C1-01	C1-01	P1-04	C1-01	E2-01	P4-10
P1-06	P1-04	Q2-02	C1-02	C1-02	P1-06	C1-02	E2-04	P5-04
P4-10	P1-06	Q2-03	P1-03	P1-03	P1-08	P1-03	L5-01	
P5-04	P2-02	Q2-04	Q1-01	Q1-01	P1-09	Q1-01	L5-04	
	P4-10	Q2-05	P1-04	P1-06	L5-40	P1-06	P1-06	
	P5-04	Q2-06	P1-06	P1-08	P1-11	P1-08		
		Q2-07	P1-08	P1-09	P1-12	P1-09		
		Q2-08	P1-09	P1-11	L5-41	P1-11		
		Q2-09	P1-11	P1-12	P1-15	P1-12		
		Q2-10	P1-12	P4-01	P1-16	P4-01		
		Q2-11	P2-02	P4-02	L5-50	P4-02		
		Q2-12	P2-03	P4-03	P1-19	P4-03		
		P4-10	P4-01	Q3-01	P1-20	Q3-01		
		P5-04	P4-02	Q3-02	P1-23	Q3-02		
			P4-03		L5-51			
			Q3-01		P5-04			
			Q3-02		P4-10			

<1> Available in drive software versions PRG: 8554 and later.

### ◆ Parameters Set Depending on A1-08 Setting

The following table shows the parameters that are set depending on the A1-08 initialization:

A1-08 = 3005 (A1-06 = 5) General Ext HOA		A1-08 = 3006 (A1-06 = 6) General HOA Keys	
Parameter	Value	Parameter	Value
A1-02	0	A1-02	0
b1-01	1	b1-01	1
b1-02	1	b1-02	6
b1-03	0	b1-03	0
b1-15	2	b1-15	2
b1-16	2	b1-16	7
b5-01	0	b5-01	0
C1-01	25.0 s	C1-01	25.0 s
C1-02	25.0 s	C1-02	25.0 s
H1-02	26H	H1-02	26H
H1-05	26H	H1-05	26H
H1-08	2	H1-08	2
H2-01	0H	H2-01	0H
H2-02	AH	H2-02	AH
H3-02	20H	H3-02	20H

A1-08 = 3005 (A1-06 = 5) General Ext HOA		A1-08 = 3006 (A1-06 = 6) General HOA Keys	
Parameter	Value	Parameter	Value
H3-06	1FH	H3-06	1FH
H3-10	0	H3-10	0
L5-04	180.0 s	L5-04	180.0 s
o1-06	0	o1-06	0
P1-05	0 s	P1-05	0 s
P1-06	0.0 Hz	P1-06	0.0 Hz
P4-12	0.0 Hz	P4-12	0.0 Hz
P4-17	0.0 min	P4-17	0.0 min
P5-01	0	P5-02	0.0 Hz
P5-03	1	P5-03	1
P5-04	0		

◆ Parameters Displayed Depending on A1-08 Setting

The following table shows which parameters are shown on the Pump Quick Setting menu depending on the A1-08 selection:

A1-08 = 3005 (A1-06 = 5) General Ext HOA	A1-08 = 3006 (A1-06 = 6) General HOA Keys
C1-01	C1-01
C1-02	C1-02
E2-01	E2-01
E2-04	E2-04
H1-02	H1-02
H1-03	H1-03
H1-05	H1-05
H1-22	H1-22
H1-23	H1-23
H1-25	H1-25
L5-01	L5-01
L5-04	L5-04
P1-06	P1-06
P5-05	P5-02

# 4.6 iQpump Presets and Functions

## ◆ Pump Down Level Control Application Preset

This preset allows the drive to regulate the depth of water in a tank or other vessel that is being filled by an external source. A feedback device that measures water depth is wired to the drive. A PI-control process loop will then modulate the pump speed to pump water out the tank to keep the water depth the setpoint level (pump out at the recharge rate). The drive controller has an application preset to simplify the start up and control of this application.

- System units are in feet (P1-02 = 6).
- Feedback device scaling (P1-03). The feedback device scaling must be entered into the drive for proper control.
- Minimum pump speed (P1-06). Most pumps cannot be run below a certain speed or cavitation can occur.
- Number of Motor Poles (E2-02). The default is for a 2-pole motor.
- Sleep Function. The drive controller will sleep when the system demand is low and awaken when demand returns.

## ■ Required Control Wiring

Most depth level transducers have current-based feedback (4-20 mA). The A2 terminal of the drive is preset for 4-20 mA and pre-programmed for PI feedback (H3-10 = B). If the sensor is voltage based (0-10 V) and terminal A3 is unused, then wire the transducer to terminal A3 and program H3-10 to F (A2 not used) and H3-06 to B (A3 PI Feedback).

## ■ Start Up Procedure

1. Set parameter A1-03 to 6009 (Pump Down Level) to pre-set parameter values for this application.
2. Set the motor-rated current in parameter E2-01. This information can be found on the motor nameplate or specification sheet.
3. Set the number of motor poles in parameter E2-04 (2-pole motors have a rated RPM of slightly less than 3600 RPM; 4-pole motors have a rated RPM of slightly less than 1800 RPM). This information can be found on the motor nameplate or specification sheet.
4. Set the feedback device scaling in parameter P1-03. Check the sensor nameplate or specification sheet. For example, if the device outputs 20 mA at 14.50 ft of water depth, the set P1-03 to 14.50. The drive controller will automatically scale all associated parameters and monitors. Monitor U1-91 (Pump Feedback) will display the measured water depth in feet. The drive has a High Feedback Fault set in parameter P1-11. Make sure that P1-11 is appropriately set for sensor scaling in P1-03.
5. Set the desired water depth level in parameter Q1-01 (PI setpoint). This is desired water depth that the drive will regulate the pump speed around. To quickly access this parameter, press the HOME key and then the ENTER key. The U1-99 monitor on the home screen displays the Q1-01 PI setpoint.
6. Set parameter P1-04 Start/Draw Down Level PSI value. It is mandatory to program the Start / Draw Down Level in order to use the sleep function. When the iQpump is turned ON and the feedback signal level (transducer) falls below the P1-04 PSI set value, the pump system will wake from sleep and start after the time specified in P1-05 (default 1 sec). The P1-04 PSI value can be set as either an Absolute level or Delta level from the setpoint.

**Absolute Level Example:** A Start /Draw Down Level P1-04 set to 50 PSI and delay time P1-05 set to 5 sec. The pump system will start when the pressure drops below 50 PSI for 5 sec.

Refer to the P1-04 row in Step 7 on page 7 for details.

7. Set the minimum speed that the pump can be run in parameter P1-06. The default is 40 Hz. This information can be found on the pump specification sheet.
8. The default settings will allow the drive to automatically restart after power loss if the drive was running at the time of power loss. To disable, set P4-10 to 1.
9. Press the AUTO key to start the drive with PI control (water depth control). Press the OFF key to stop the drive.
10. The pump can be run in a Hand (local) mode for maintenance purposes by pressing the HAND key while the drive is stopped. The HAND key acts as a start button. Press the OFF button to stop the drive. Press AUTO to return the drive to PI control. The HAND speed reference can be set in P5-02 (Hand Reference 1). Disable the HAND key by setting P5-04 to 0 (disabled).
11. Configure the sleep function. The pump can be programmed to shut off or “sleep” if the water falls below the depth set in parameter P2-02 (Sleep Level). The controller will monitor the water depth feedback signal and wake up when the water depth rises above the setting in parameter P1-04 (Start – Draw Down Level). Logically, set the Sleep Level (P2-02) lower than the PI setpoint and set the Draw Down Level (P1-04) slightly above the PI setpoint. This way the drive won't wake up until the water has already exceeded the desired depth setting. By sleeping, the drive will save energy and mechanical wear. A setting of zero in P1-04 will disable the sleep function (default setting).

## ■ Related Parameters

No.	Parameter Name	Setting Values
A1-01	Access Level Selection	Default: 2 Range: 0 to 3
A1-03	Initialize Parameters	Default: 0 Range: 0 to 5550; 6008 to 6014; 7770, 7771
E2-01	Motor Rated Current	Default: Min.: 10% of drive rated current Max.: 200% of drive rated current
E2-04	Number of Motor Poles	Default: 2 Min.: 2 Max.: 48
P1-03	Feedback Device Scaling	Default: 145.0 PSI Min.: 0.1 Max.: 6000.0
P1-11	High Feedback Level	Default: 0.0 PSI Min.: 0.0 Max.: 6000.0
P1-06	Minimum Pump Speed	Default: 40.0 Hz Min.: 0.0 Max.: [E1-04]
P1-04	Start / Draw Down Level	Default: 0.0 Min.: -999.9 Max.: 999.9
P2-02	Sleep Level	Default: 0.0 Hz Min.: 0.0 Max.: 6000.0
P4-10	AUTO Mode Operator Run Power Down Storage	Default: 0 Range: 0, 1
P5-02	HAND Speed Reference 1	Default: 40.0 Hz Min.: 0 Max.: [E1-04]
P5-04	HAND Key Function Selection	Default: 1 Range: 0, 1
Q1-01	PID Controller Setpoint 1	Default: 0.0 Min.: 0.0 Max.: 6000.0
U1-99	Anti-No-Flow Timer	No signal output available

### ◆ Suction Control via Constant Pressure w/Well Draw Down

This function enables the iQpump Controller to monitor suction pressure at the inlet of the pumps.

**Note:** This function is active when parameter Q5-01 is set to 1 for Suction Control.

Packaged Booster Systems have a desired discharge pressure and a given suction pressure from the city water system or from a suction tank. Such systems are often designed to handle a specific pressure and flow rate.

The suction pressure may have a wide range between high and low pressures. The suction pressure typically decreases with increased fluid flow rate. In some instances, pump cavitation may occur if suction pressure falls below a certain pressure level.

In addition, low or negative suction pressure can lead to damage such as pipe collapse due to external forces acting on the pipe.

The iQpump Controller will accept an analog suction transducer (Terminal A1) and can be programmed to trigger an alarm or shutdown the system when the suction pressure falls outside of a normal operating range. The iQpump Controller will automatically restart and return to normal operation once the suction pressure returns to a normal level.

When operating in multiplex mode, additional control can be programmed to de-stage any active pumps as a method to try and reduce pump loading to prevent suction pressure from continuing to drop below the shut down level.

### ■ Function Description

The iQpump Controller will regulate outlet pressure of the pump system using the standard iQpump Controller features when there is adequate suction pressure available at the inlet of the pumps and offers two options to respond to a drop in suction pressure.

#### 1. Regulate Outlet Pressure and Suction Pressure: $Q5-03 \geq Q5-04$

To regulate suction pressure set the suction pressure setpoint (Q5-03) to a value greater or equal than the minimum suction pressure (Q5-04). In this mode the iQpump Controller will try to regulate the suction pressure based on the programmed suction pressure setpoint (Q5-03) level.

As the suction pressure decreases and approaches the suction pressure setpoint level (Q5-03), the iQpump Controller will slow down causing the outlet pressure and flow to decrease. When the suction pressure rises above the Q5-06 level for longer than the Q5-07 time, normal operation (outlet pressure regulation) will resume.

The iQpump controller goes to sleep when the suction pressure drops below Minimum Suction Pressure (Q5-04), for longer than the Sleep Delay Time (Q5-05).

**Note:** The Suction Control Minimum Speed parameter (Q5-08) should be set to a high enough value that will ensure flow.

#### 2. Regulate Outlet Pressure Only: $(Q5-03 < Q5-04)$

Set the suction pressure setpoint (Q5-03) to a value smaller than the minimum suction pressure (Q5-04) to regulate outlet pressure.

This mode allows the iQpump Controller to maintain the outlet pressure setpoint using the standard iQpump Controller features and go to sleep immediately when the suction pressure drops below the Minimum Suction Pressure (Q5-04), for more than the Sleep Delay Time (Q5-05).

Normal operation (outlet pressure regulation) resumes when the suction pressure rises above the Q5-06 level for longer than the Q5-07 time.

### ■ Duplex System Example

**Example:** A pump system consisting of a duplex domestic pressure booster system using a pressured city supply averaging 40 - 60 psi. When city pressure starts to fall below 40 psi, the pump system will start to slow down to reduce the chances of pump cavitation. When suction pressure (city pressure) drops to 30 psi, the pump system will shut down (sleep) and wait until city pressure returns, after which the system will automatically start and operate under normal conditions.

#### Pump System Settings

- All pumps have the same flow rate and will alternate
- Lag Pump will track speed of lead pump
- All drives have individual discharge transducers rated 150 psi. Upon failure, system will look to network for feedback information.
- Suction Transducer is rated 75 psi
- Below 40 psi city pressure the pump system will start to reduce speed until reaching 30 psi
- System Auto setpoint 85 psi, with a 5 psi start level.



**Duplex System Example (Related Parameters)**

No.	Parameter Name	Booster Pump 1	Booster Pump 2
H3-02	Terminal A1 Gain	231.3%	231.3%
H3-03	Terminal A1 Bias	-25.0%	-25.0%
H3-08	Terminal A2 Signal	2	2
H5-01	Drive Node Network Address	1	2
P1-01	Pump Mode	3	3
P1-03	FD Device Scaling	150 psi	150 psi
P1-04	Start Level	-5.0 psi	-5.0 psi
P9-02	Feedback Source	2	2
P9-05	Lag Drive Mode	2	2
P9-25	Highest Node Address	3	3
P9-50	Suction Pressure Source	2	2
Q5-01	Suction Pressure Selection	1	1
Q5-02	Suction Transducer Scaling	75 psi	75 psi
Q5-03	Suction Pressure Setpoint	40.0 psi	40.0 psi
Q5-04	Minimum Suction Pressure	30.0 psi	30.0 psi
Q5-06	Wake-up Suction Pressure	40.0 psi	40.0 psi
U1-01	Auto Setpoint	85 psi	85 psi

**■ Enabling Suction Pressure Control**

The suction pressure control selection is added to parameter Q5-01 Water Level/Suction Pressure Selection. Follow the steps below for basic suction pressure control setup:

1. Enable suction control by setting parameter Q5-01 to 1 (Suction Control).
2. Set suction transducer scaling (Q5-02) in psi, scaling for analog input A1 (20 mA scale).
3. Set suction pressure setpoint (Q5-03) in psi.
4. Select iQpump operation when a drop in suction pressure occurs:
  - Regulate outlet pressure only and go to sleep immediately when suction pressure falls below minimum suction pressure level (Q5-04). Set suction pressure setpoint (Q5-03) below minimum suction pressure level (Q5-04).
  - Regulate suction pressure when pressure is below suction pressure setpoint (Q5-03) but above the minimum suction pressure level (Q5-04). Set suction pressure setpoint (Q5-03) to above the minimum suction pressure level (Q5-04).
5. Set minimum suction pressure (Q5-04) – Sleep Level for Suction Control.
6. Set suction pressure wake-up level (Q5-06) – Wake-up level.
7. Set suction control minimum speed (Q5-08) – Minimum Flow Speed.

### ◆ Geothermal Mode Application Preset

A geothermal well facilitates heat transfer between the earth and a known system, such as space heating, dehydration, electric power generation and food processing. The geothermal function has the ability to regulate the speed of the drive controller based on an external temperature signal following a preset temperature-speed curve. The drive controller has an application preset to simplify the start up and control of this application

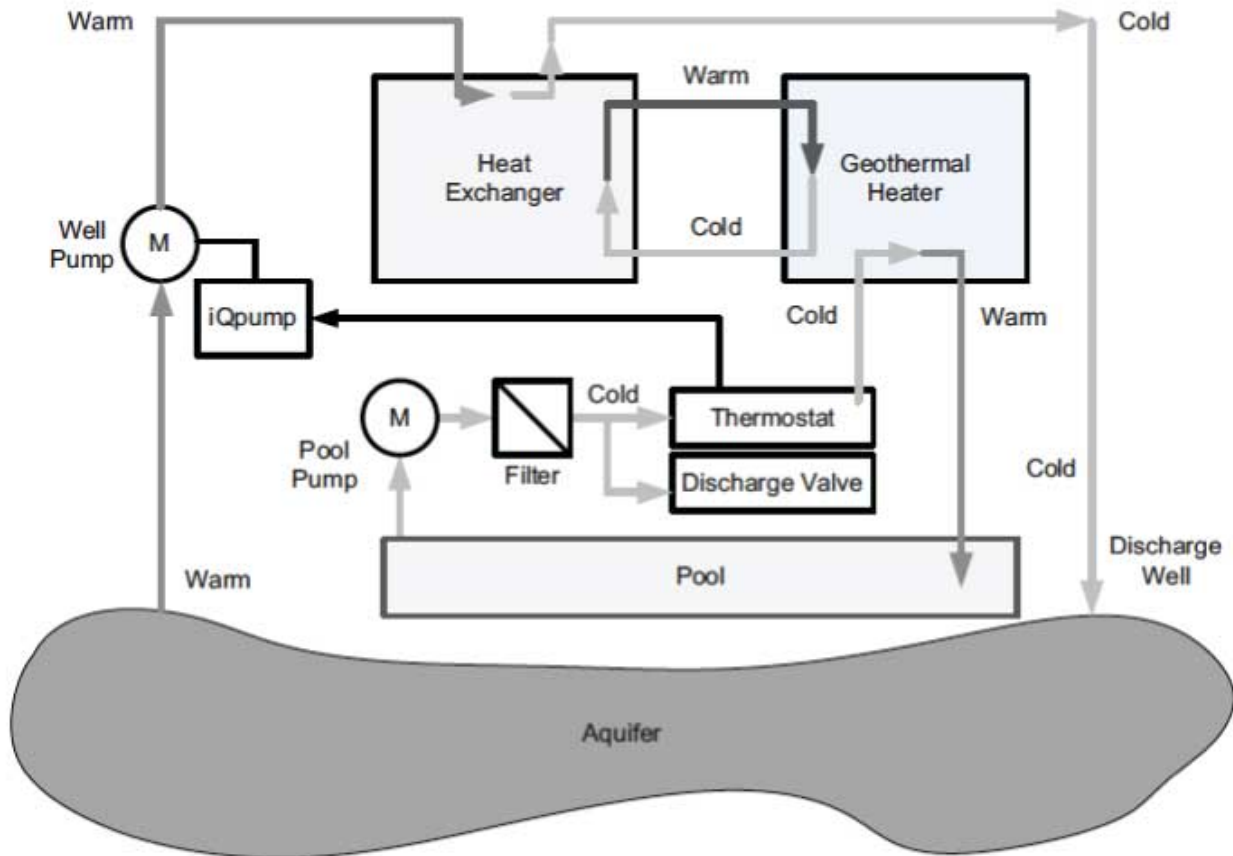

### ■ Required Control Wiring

Most temperature transducers have current-based feedback, (4 - 20 mA). The A2 terminal of the drive is pre-set for 4 to 20 mA and Temperature Feedback (H3-10 = 21). If the sensor is voltage-based (0 to 10 V) and terminal A3 is unused, then wire the transducer to terminal A3 and program H3-10 to F (A2 not used) and H3-06 to 21 (A3 Temperature Feedback).

### ■ Start Up Procedure

1. Set parameter A1-03 to 6010 (Geothermal Mode) to pre-set parameter values for this application. The second line of the HOA Keypad will read "Geothermal Mode".
2. Set the method of giving the drive a run command in parameter b1-02. The default setting is to use the AUTO key on the HOA keypad.
3. Set the motor-rated current in parameter E2-01. This information can be found on the motor nameplate or specification sheet.
4. Set the number of motor poles in parameter E2-04 (2-pole motors have a rated RPM of slightly less than 3600 RPM; 4-pole motors have a rated RPM of slightly less than 1800 RPM). This information can be found on the motor nameplate or specification sheet.
5. Set the minimum speed at which the pump can run in parameter P1-06. The default is 40 Hz. This information can be found on the pump specification sheet.
6. Set the feedback device scaling in parameters Q2-01 and Q2-02. Q2-01 sets the temperature at 0 V (4 mA). Q2-02 sets the temperature at 10 V (20 mA). The monitor for this feedback is U1-80 (Geothermal Temperature).
7. Set the pump speed-temperature characteristics in Q2-03 to Q2-08. This allows the drive to modulate the pump speed based on the analog input temperature feedback of the water. This will attempt to regulate the water temperature between the Q2-06 and Q2-07 settings. **Figure 4.7** shows normal operation.

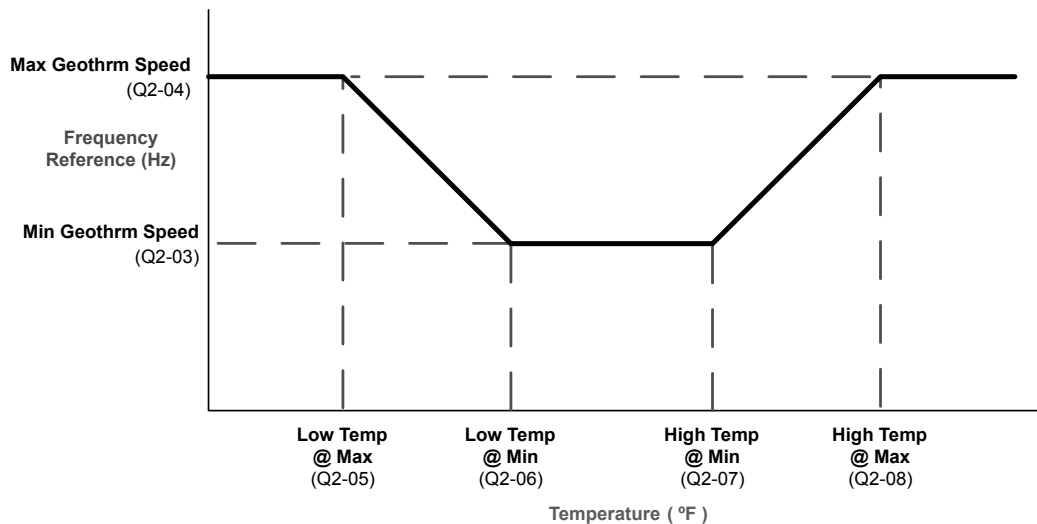

Figure 4.7 Normal Temperature Regulation

The drive can also be programmed for inverse operation by changing the parameter settings in Q2-03 to Q2-08 as shown in [Figure 4.8](#).

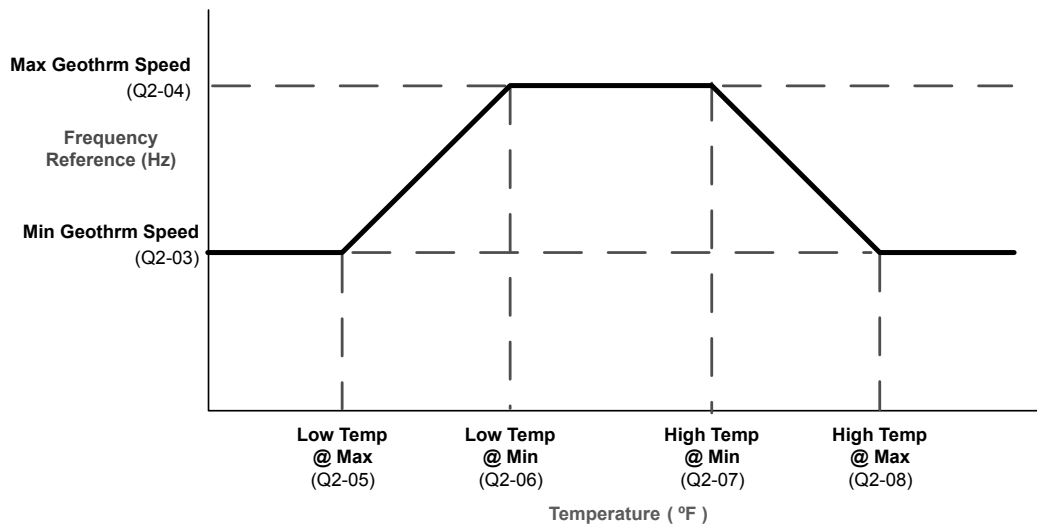

Figure 4.8 Inverse Temperature Regulation

8. Set the response to temperature feedback signal loss. The drive will monitor the feedback signal for signal loss. This function can be disabled by setting Q2-09 to 0. When a wire break is detected (or if no analog input is programmed for Geothermal Temp), a "TLGI - Geothermal Input" fault or "Temp Lost – Geothermal Input" alarm will be triggered depending on the setting of Q2-09. If Q2-09 is set to 2 (fault), the drive will only fault when running in AUTO Mode. It will only display the alarm if not running or if it is running in HAND Mode.
9. Set the Geothermal Sleep characteristics. The drive will sleep if the drive runs at the minimum speed (Q2-03) for the time set in Q2-10. Setting Q2-11 to 0 disables the sleep function (default setting).
10. Set the wake up characteristics. The drive will wake from Geothermal Sleep when Geothermal Temperature (U1-80) is greater than the "High Temp @ Min" plus the Geothermal Wake Level (Q2-07 + Q2-11) or is less than "Low Temp @ Min" minus the Geothermal Wake Level (Q2-06 – Q2-11) for more than the Geothermal Wake Delay Time (Q2-12).
11. The default settings will allow the drive to automatically restart after power loss if the drive was running at the time of power loss. Set P4-10 to 1 to disable this function.
12. Press the AUTO key to start the drive with PI control (water depth control). Press the OFF key to stop the drive.

## 4.6 iQpump Presets and Functions

- 13.** The pump can be run in HAND (LOCAL) Mode for maintenance purposes by pressing the HAND key while the drive is stopped. The HAND key acts as a start button. Press the OFF button to stop the drive. Press AUTO to return the drive to geothermal control. The HAND speed reference can be set in P5-02 (Hand Reference 1). Disable the HAND key by setting P5-04 to 0 (disabled).

### ■ Related Parameters, Faults, and Alarms

No.	Parameter Name	Setting Values
A1-01	Access Level Selection	Default: 2 Range: 0 to 3
A1-03	Initialize Parameters	Default: 0 Range: 0 to 5550; 6008 to 6014; 7770, 7771
b1-02	Run Command Selection 1	Default: 0 Range: 0 to 3; 6 to 8
E2-01	Motor Rated Current	Default: Min.: 10% of drive rated current Max.: 200% of drive rated current
E2-04	Number of Motor Poles	Default: 2 Min.: 2 Max.: 48
P1-03	Feedback Device Scaling	Default: 145.0 PSI Min.: 0.1 Max.: 6000.0
P1-04	Start / Draw Down Level	Default: 0.0 Min.: -999.9 Max.: 999.9
P1-06	Minimum Pump Speed	Default: 40.0 Hz Min.: 0.0 Max.: [E1-04]
P1-11	High Feedback Level	Default: 0.0 PSI Min.: 0.0 Max.: 6000.0
P2-02	Sleep Level	Default: 0.0 Hz Min.: 0.0 Max.: 6000.0
P4-10	AUTO Mode Operator Run Power Down Storage	Default: 0 Range: 0, 1
P5-02	HAND Speed Reference 1	Default: 40.0 Hz Min.: 0 Max.: [E1-04]
P5-04	HAND Key Function Selection	Default: 1 Range: 0, 1
Q1-01	PID Controller Setpoint 1	Default: 0.0 Min.: 0.0 Max.: 6000.0
Q2-01	Minimum Geothermal Temperature Input	Default: 0.0 °F Min.: -110.0 Max.: 275.0
Q2-02	Maximum Geothermal Temperature Input	Default: 120.0 °F Min.: -100.0 Max.: 275.0
Q2-03	Minimum Geothermal Speed	Default: 40.0 Hz Min.: 0.0 Max.: 400.0
Q2-04	Maximum Geothermal Speed	Default: 60.0 Hz Min.: 0.0 Max.: 400.0

No.	Parameter Name	Setting Values
Q2-05	Low Temperature to Run at Maximum Geothermal Speed	Default: 55.0 °F Min.: -110.0 Max.: 275.0
Q2-06	Low Temperature to Run at Minimum Geothermal Speed	Default: 65.0 °F Min.: -110.0 Max.: 275.0
Q2-07	High Temperature to Run at Minimum Geothermal Speed	Default: 75.0 °F Min.: -110.0 Max.: 275.0
Q2-08	High Temperature to Run at Maximum Geothermal Speed	Default: 85.0 °F Min.: -110.0 Max.: 275.0
Q2-09	Geothermal Temperature Loss Detection	Default: 1 Range: 0 to 2
Q2-10	Geothermal Sleep Delay Time	Default: 30 s Min.: 0 Max.: 3600
Q2-11	Geothermal Temperature Delta Wake Level	Default: 0.0 °F Min.: 0.0 Max.: 50.00
U1-99	Anti-No-Flow Timer	No signal output available

H3 Multi-Function Analog Input Settings		
H3-□□ Setting	Function	Description
21	Geothermal Temperature	Full scale: Q2-02 = 10 V (or 20 mA), Q2-01 = 0 V (or 4 mA) This input is internally limited to -999.9 °F to +999.9 °F
F	Not Used	Disables the functionality of the programmed terminal.

HOA Keypad Display	Error Name
oPE29	Geothermal Set Error
<b>Cause</b>	<b>Possible Solutions</b>
P1-01 parameter selection is not compatible with Geothermal Mode (b1-01 = 5).	Confirm b1-01 and P1-01 parameter settings.

HOA Keypad Display	Fault Name
TLGI Geothermal Input	Temperature Lost Geothermal Input The geothermal input is not present.
<b>Cause</b>	<b>Possible Solutions</b>
The input signal level has dropped below 3 mA or risen above 21 mA when the drive was running and b1-01 = 5, H3-0□ = 21 (Geothermal Input), H3-0□ = 2 (4 to 20 mA), and Q2-09 = 2 (Fault).	Confirm that the device connected to the analog input terminal is installed and working properly.
The drive was running while b1-01 = 5, H3-0□ ≠ 21 (Geothermal Temp), and Q2-09 = 2 (Fault).	Assign one of the analog inputs to “Geothermal Temperature”, H3-0□ = 21.

HOA Keypad Display	Minor Fault Name
Geo Params Chk Q2-05 to Q2-08	Geothermal Mode Parameters The drive is running at the level set in Q2-03 due to an incorrect setting.
<b>Cause</b>	<b>Possible Solution</b>
The temperature parameter values are set incorrectly.	Set the temperature parameters in the following order: Q2-08 > Q2-07 > Q2-06 > Q2-05

## 4.6 iQpump Presets and Functions

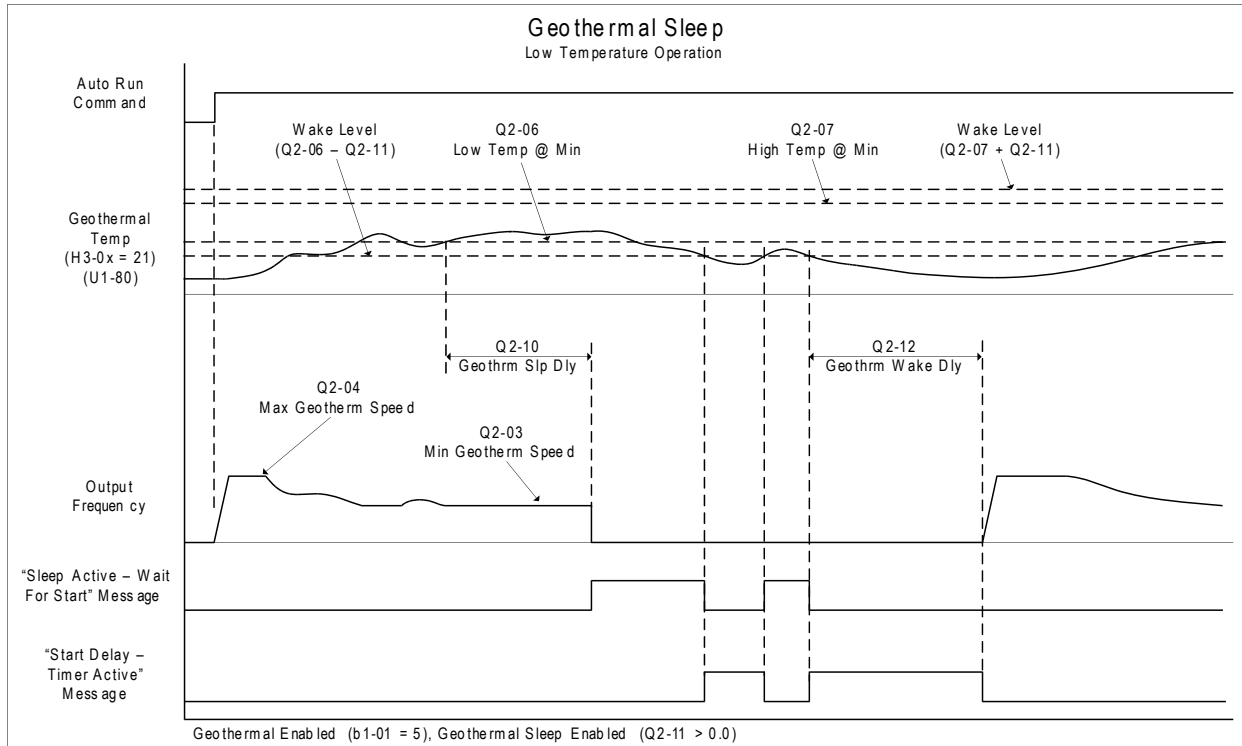

**Figure 4.9 Geothermal Sleep – Low Temperature Operation**

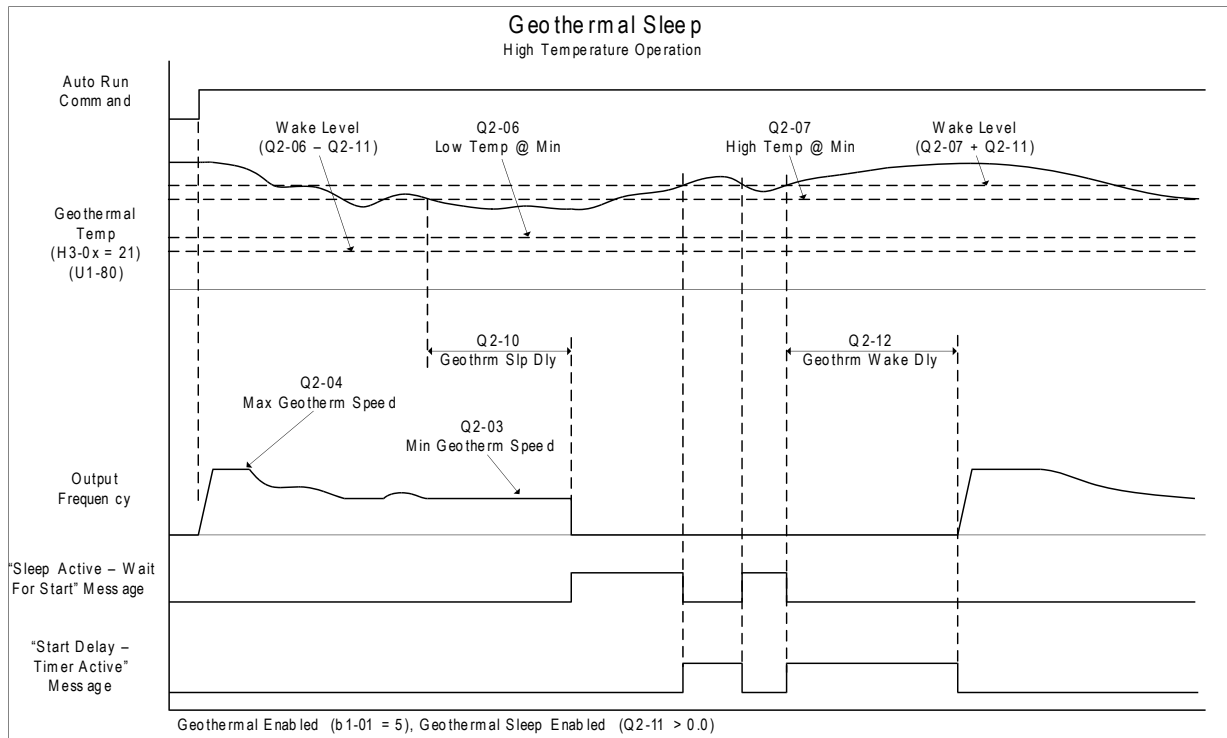

**Figure 4.10 Geothermal Sleep – High Temperature Operation**

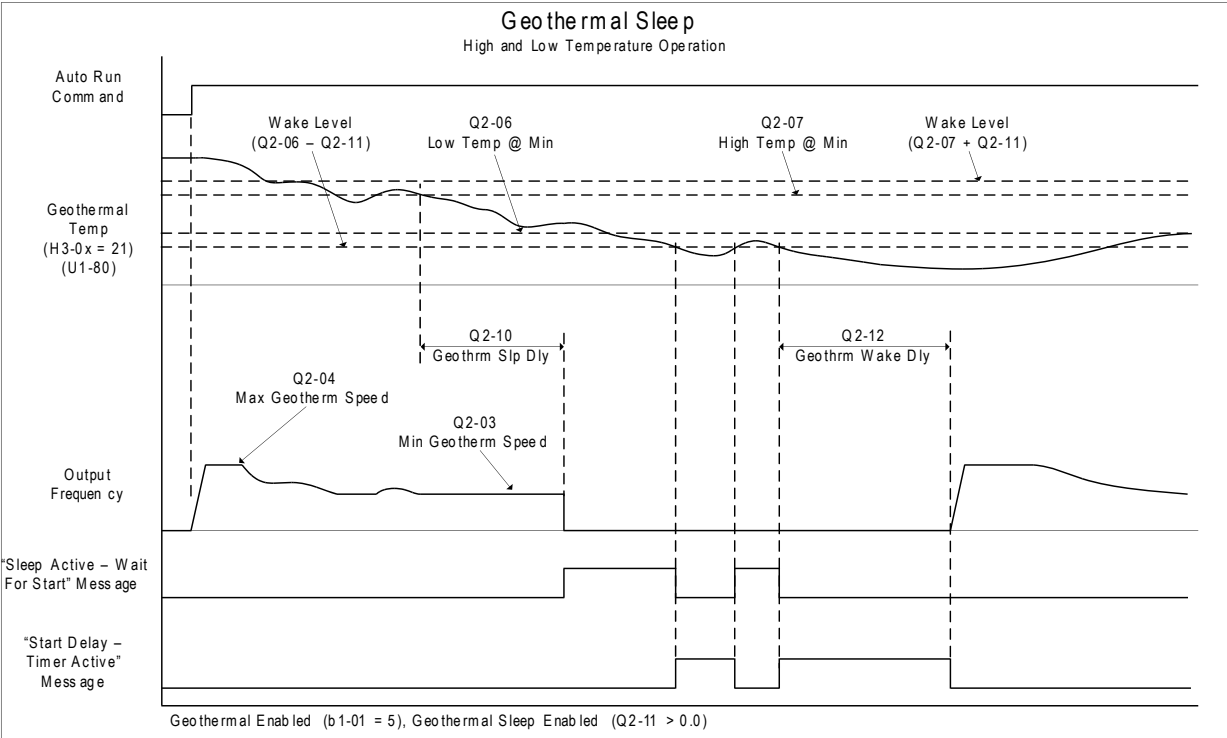

Figure 4.11 Geothermal Sleep – High and Low Temperature Operation

### ◆ General Purpose Mode Application Preset

The purpose of this mode is to allow the drive controller to run a motor at a set speed without the PI process loop. This preset is designed to simplify using the drive for applications other than pumping control. The default settings call for the frequency reference to be an analog input and the run command to come from the terminal strip via a maintain contact closure. The PI loop is disabled and no process feedback is required.

#### ■ Required Control Wiring

No additional control wiring is required when the drive controller is at its default settings.

#### ■ Start Up Procedure

1. Set parameter A1-03 to 7770 (General Purpose Mode) to pre-set parameter values for this application.
2. Set the source of the frequency reference for the drive controller in parameter b1-01. The default setting is from the terminal strip via a 0 to 10 V analog signal wired into terminal A1.
3. Set the source of the Run Command for the drive controller in parameter b1-02. The default setting is from the terminal strip via a maintained contact closure.
4. Set the Acceleration Time of the motor in parameter C1-01. This is the time to accelerate the motor from zero speed to 60 Hz (E1-04 Maximum Output Frequency).
5. Determine the stopping method of the motor. The default setting is coast to stop. To ramp the motor to a stop, set b1-03 to 0 and then set the motor deceleration time in parameter C1-02. This is the time to stop the motor from 60 Hz (E1-04 Maximum Output Frequency) to zero speed.
6. Set the motor-rated current in parameter E2-01. This information can be found on the motor nameplate or specification sheet.
7. Set the number of motor poles in parameter E2-04 (2-pole motors have a rated RPM of slightly less than 3600 RPM; 4-pole motors have a rated RPM of slightly less than 1800 RPM). This information can be found on the motor nameplate or specification sheet.
8. Determine whether the drive controller should attempt to reset itself after a fault. The default setting is disabled. The function is turned on by setting 1 to 10 reset attempts in parameter L5-01 and the time between each reset in parameter L5-04.
9. Set the minimum speed at which the motor can run in parameter P1-06. The default is 0 Hz. If the system has a minimum safe operation speed, set it in P1-06. This will act as a lower limit of the frequency reference.
10. The motor can be run in HAND (LOCAL) Mode for maintenance purposes by pressing the HAND key while the drive is stopped. The HAND key acts as a start button. Press the OFF button to stop the drive. Set P5-04 to 0 to disable the HAND key. The default frequency reference is 0.0 Hz in HAND Mode. This can be changed in parameter P5-02. The AUTO key has no effect with the default settings in the General Purpose Application Preset.

#### ■ Related Parameters

No.	Parameter Name	Setting Values
A1-03	Initialize Parameters	Default: 0 Range: 0 to 5550; 6008 to 6014; 7770, 7771
b1-01	Frequency Reference Selection 1	Default: 0 Range: 0 to 5
b1-02	Run Command Selection 1	Default: 0 Range: 0 to 3; 6 to 8
b1-03	Stopping Method Selection	Default: 1 Range: 0 to 3
C1-01	Acceleration Time 1	Default: 20.0 s Min.: 0.0 Max.: 6000.0
C1-02	Deceleration Time 1	Default: 20.0 s Min.: 0.0 Max.: 6000.0
E1-04	Maximum Output Frequency	Default: 60.0 Hz Min.: 40.0 Max.: 400.0



No.	Parameter Name	Setting Values
E2-01	Motor Rated Current	Default: Min.: 10% of drive rated current Max.: 200% of drive rated current
E2-04	Number of Motor Poles	Default: 2 Min.: 2 Max.: 48
L5-01	Number of Auto Restart Attempts	Default: 5 Min.: 0 Max.: 10
L5-04	Fault Reset Interval Time	Default: 20.0 s Min.: 10.0 Max.: 3600.0
P1-06	Minimum Pump Speed	Default: 40.0 Hz Min.: 0.0 Max.: [E1-04]
P5-02	HAND Reference	Default: 40.0 Hz Min.: 0 Max.: [E1-04]
P5-04	HAND Key Function Selection	Default: 1 Range: 0, 1

### ◆ Well Draw Down Control Application Preset

The Well draw down function allows the drive to deliver water at a constant pressure as long as ground water level remains above a specified level. If the ground water level drops to this specified level the drive will switch from a constant pressure regulator to a level regulator, which will continue to supply water at the recharge rate of the well. Water will continue to flow at a reduced rate. Should the water level down hole continue to drop the drive will go to sleep and wait till the water level rises again to the specified wake up level to start pumping again. Once the water level rises above that level it will switch back to constant pressure mode.

#### ■ Start Up Procedure

The following is a sample setup for the Well Draw Down function with 4 to 20 mA transducer feedback on both level (connected to input A1) and constant pressure (connected to A2)

1. Select a Proper Depth Sensing Transducer. The proper transducer for depth sensing has been specifically designed for depth sensing. This means the transducer element, electrical connections, and connecting cable are sealed for submersion. Additionally the sensor will have a vent tube running the length of the electrical conductors to compensate for changes in barometric air pressure, which ensures accurate feedback with changing weather patterns. Another important design characteristic is that the electrical conductors are installed by the manufacturer at the length specified by the installer. This ensures that the manufacturer can calibrate the transducer to compensate for the voltage drop across the conductor length. The maximum length for pressure transducer leads is 50 meters (164 feet) and beyond that length the voltage drop will cause inaccurate feedback. It is common for wells to exceed this depth. Do not use standard pressure transducer for level control. Select a range of depth that closely matches your application range. One size does not fit all as depth calculations work with small changes in feedback. If the range is too large accuracy will be compromised.

Proper Depth Transducer Characteristics:

Sealed element and electrical connections

Barometric compensation

Specified cable length calibrated by the manufacturer

Proper range, one that is close to applications actual operation

2. Install Depth Sensing Pressure Transducer Down Hole. Since the feedback from the transducer is low voltage and the output of the drive to the motor is a PWM waveform an effort should be made to keep the transducer leads as far from the motor leads as possible. Given that space in the bore hole is at a premium this is a difficult task and connection of the transducer shield drain wire is important. Many installers will set the transducer in its own plastic tubing with a cap at the bottom end that the transducer can rest on. It is necessary to drill holes in the tubing at or close to the bottom to allow water to flood the tube. This type of installation will help protect the transducer and connecting cable from damage and allow it to be retrieved if necessary.
3. Connect Level Transducer to the drive via Terminal A1. Most depth level transducers are current based feedback, typically 4 to 20 mA. The A1 terminal of the drive is selectable for either voltage or current based pressure transducer feedback. Most transducers in common use are current based (4 to 20 mA).
4. Set the drive to accept current based (4 to 20 mA) Feedback Set the A1 terminal of Jumper S1 to current type input (I) as shown in [Figure 4.12](#). Set parameter H3-01 to 2 (4 to 20 mA) for signal type on A1. Set parameter H3-02 to 23, function of the A1 input, Well Level feedback

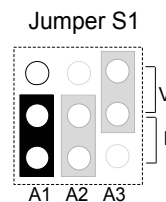

Figure 4.12 Terminal A1 Set to Current Input

Table 4.6 Jumper S1 Settings

Setting	Description
V (top position)	Voltage input (0 to 10 V Bipolar)
I (bottom position)	Current input (4 to 20 mA or 0 to 20 mA)

5. Connect Standard Pressure Transducer to Terminal A2. Terminal A2 is designed to accept both current and voltage based feedback devices and by default the drive is set to 4 to 20 mA input. Make sure to set all necessary parameters for proper constant pressure regulation.

6. Set parameter Q4-01 to 1 to enable the Well Draw Down Feature.
7. Set Constant Pressure Setpoint in U1-01 or Q1-01. U1-01 is the only monitor which will change parameter values without going to the program menu. Using this monitor, the setpoint can be changed while the drive is running. A setpoint must be entered for the Well Draw Down feature to work properly.
8. Enter the maximum value of the range of the transducer in PSI in parameter Q4-02 and the drive will automatically scale associated parameters. The level transducer should display a specification for range (e.g., 0 to 50 PSI [115.4 feet]) 1 PSI = 2.308 ft.
9. Set Well Level to be maintained in parameter Q4-03 This is the level (in feet) at which the drive will stop regulating pressure and start maintaining level. If the water level rises above this level, the drive will automatically switch back to pressure regulation.
10. Set Well Level to Sleep in parameter Q4-04 When the well level reaches this level (in feet) and the sleep time set in parameter Q4-05 expires, the drive will go to sleep and stop running the pump. The pump will remain in this state until the well level reaches the wake level set in Q4-06.
11. Set Wake Level in parameter Q4-06. When the well level has reached this level (in feet) and the on-delay timer set in Q4-07 expires, the drive will automatically start running again. Set this level should to a value greater than Q4-03 (Maintain Level) so the drive will automatically go to pressure regulation mode.
12. Set the Minimum Pump Speed while in Level Control in parameter Q4-08 Set this speed at a level which ensures that the pump is moving water out of the well. If it is set to a speed where no water is moving, the PI regulator may not drive the well level to the sleep level and cause damage to the pump or motor. This speed is only used in Level Control Mode but the actual minimum speed in Level Mode will be the greater value between P1-06 (minimum pump frequency) and P4-05 (thrust frequency). If Q4-08 is set higher than P1-06 and P4-05, it will only be used while the drive is in Level Control Mode.
13. Set Low Level Detection Value in Parameter Q4-09 and program the drive response in Q4-11 This is the level (in feet) at which you do not want the pump to run at because below this level there is a danger dry running. Generally this level is a fail safe level and if reached you would likely want the drive to fault out and stop running immediately. This can also activate the drive fault contacts, which can be used for auxiliary notification such as a horn or external warning light. In Q4-11 the drive can be programmed for one of four responses 0. No Response, 1. Alarm Only, 2. Fault 3. Time Delay. Default is Alarm Only. Note: option 3 is controlled by parameters Q4-12 (timer) and L5-01 > 0 (fault auto-restart).
14. Verify Settings and Well Level in Monitor U1-97 By using monitor U1-97 (displayed in feet) without the pump running you should see the well level displayed and can note it down. Then press the Auto button to start the drive in pressure regulation mode. This assumes all other parameters for pressure regulation have been set up prior to this step. Once the setpoint pressure has been reached check U1-97 and note the level. Depending on the recharge rate of the well this value will be lower than the level without the pump running by some amount. This can give you an idea of the well's recharge rate at the current demand. It will give you an idea if the other levels you have set are appropriate. The level should be checked periodically over the season of operation to check level variations related to times of the year.

## ■ Related Parameters

No.	Parameter Name	Setting Values
H3-01	Terminal A1 Signal Level Selection	Default: 0 Range: 0 to 3
H3-02	Terminal A1 Function Selection	Default: 0 Range: 0 to 32
L5-01	Number of Auto Restart Attempts	Default: 5 Minimum: 0 Maximum: 10
P1-06	Minimum Pump Speed	Default: 40.0 Hz Minimum: 0.0 Maximum: [E1-04]
P4-05	Pre-Charge Loss of Prime Level	Default: 0.0 A Minimum: 0.0 Maximum: 1000.0
Q1-01	PID Controller Setpoint 1	Default: 0.0 Minimum: 0.0 Maximum: 6000.0
Q4-01	Water Level Selection	Default: 0 Range: 0, 1

## 4.6 iQpump Presets and Functions

No.	Parameter Name	Setting Values
Q4-02	Water Level Scaling	Default: 100 PSI Minimum: 5 Maximum: 500
Q4-03	Water Level Setpoint	Default: 20.0 ft Minimum: 0.0 Maximum: 1200.0
Q4-04	Minimum Water Level	Default: 10.0 ft Minimum: 0.0 Maximum: 1200.0
Q4-05	Water Level Sleep Delay Time	Default: 5 s Minimum: 0 Maximum: 3600
Q4-06	Wake-Up Water Level	Default: 30.0 ft Minimum: 0.0 Maximum: 1200.0
Q4-07	Water Level Control Sleep Wake-Up Time	Default: 1 s Minimum: 0 Maximum: 3600
Q4-08	Level Control Minimum Speed	Default: 0.00 Hz Minimum: 0.00 Maximum: 400.00
Q4-09	Low Level Detection Level	Default: 0.0 ft Minimum: 0.0 Maximum: 1200.0
Q4-10	Low Level Detection Time Delay	Default: 0.0 Minimum: 0.0 Maximum: 300.0
Q4-11	Low Level Behavior	Default: 1 Range: 0 to 3
Q4-12	Water Level Control Auto-Restart Time	Default: 5.0 min Minimum: 0.1 Maximum: 6000.0
Q4-15	Low Water Level Detection Time Unit	Default: 0 Range: 0, 1
U1-01	Frequency Reference	10 V: Maximum frequency
U1-97	Water Level	Full scale: 10 V = Q4-02

## ◆ Low City or Low Suction Inlet Pressure

This function is used with low suction inlet pressure switches on pressure booster systems for buildings that get their main water supply from a municipality. This pressure switch enables and disables the pump system when the inlet supply is at a low demand and when running the pump system in this condition will cause damage.

An inlet pressure switch is wired directly into the drive using one of the digital input terminals. If the pressure switch is active and sufficient pressure is available, the drive system will operate normally. If the pressure switch indicates that incoming pressure is too low, the drive will take the following actions:

- The drive will be forced into a sleep-like state (coast to stop).
- Any drives staged in multiplex mode will immediately coast to stop.
- The selected alarm “Low City Pressure”, “Low Suction Pressure”, or “Low Water In Tank” will be displayed (determined by P4-24).

All drives will restart when sufficient pressure returns.

### ■ Required Control Wiring

Any one of the multi-function digital inputs (S1 to S8) must be wired and programmed with a low suction inlet pressure switch. The appropriate terminal parameter (H1-□□) must be set to 73 (Low City Pressure). The action of the switch (normally open / normally closed) is set in parameter P4-21.

### ■ Start Up Procedure

1. Set all other parameters required for the application such as PI control loop, sleep, motor, and I/O parameters.
2. Set one digital input for the low suction inlet pressure switch (H1-□□ = 73). Wire the switch to this terminal.
3. Configure the terminal for a normally open / closed switch type using parameter P4-21.
4. Configure the delay times for activating and removing the alarm in parameters P4-23 and P4-24. This can be used to stop the drive from cycling too frequently if the pressure varies a lot.
5. Select the alarm message that will be displayed when a Low City condition is detected using parameter P4-24. Options include “Low City Pressure”, “Low Suction Pres”, and “Low Watr In Tank”.

### ■ Related Parameters, Faults, and Alarms

No.	Parameter Name	Setting Values
P4-21	Low City Input Select	Default: 1 Range: 0, 1
P4-22	Low City On-Delay Time	Default: 10 s Minimum: 1 Maximum: 1000
P4-23	Low City Off-Delay Time	Default: 5 s Minimum: 0 Maximum: 1000
P4-24	Low City Alarm Text	Default: 0 Range: 0 to 2

#### H1 Multi-Function Digital Input Settings

H1-□□ Setting	Function	Description
73	Low City Press	Indicates that sufficient or insufficient pressure is present on the inlet to the pump. Used mainly for pressure booster situations.

HOA Keypad Display	Minor Fault Name
Low City Pressure	Low City Pressure
Cause	Possible Solution
Insufficient pressure is present on the inlet to the pump.	<ul style="list-style-type: none"> <li>• Check pressure switch contact for correct operation.</li> <li>• Check control wiring to drive terminal strip from pressure switch contact.</li> <li>• Check to make sure that suction pressure is present by means of a separate measuring device.</li> </ul>

## 4.6 iQpump Presets and Functions

HOA Keypad Display	Minor Fault Name
Low Suction Pressure	Low Suction Pressure
Cause	Possible Solution
Insufficient suction pressure is present.	<ul style="list-style-type: none"> <li>• Check pressure switch contact for correct operation.</li> <li>• Check control wiring to drive terminal strip from pressure switch contact.</li> <li>• Check to make sure that suction pressure is present by means of a separate measuring device.</li> </ul>

HOA Keypad Display	Minor Fault Name
Low Water in Tank	Low Water in Tank
Cause	Possible Solution
The water level in the tank is too low.	<ul style="list-style-type: none"> <li>• Check pressure switch contact for correct operation.</li> <li>• Check control wiring to drive terminal strip from pressure switch contact.</li> <li>• Check to make sure that suction pressure is present by means of a separate measuring device.</li> </ul>

## ◆ Water Level / Suction Pressure Control

This function provides the ability to use the Low and High Level Detection feature of Water Level or Suction Pressure Control without affecting the output speed (drive main PI control).

This function will affect the output speed only when setting Q4-01 > 0 to enable Water Level Control will and setting Q4-20 to 1 to enable Water Level Speed Control.

In all other cases, only Sleep at Minimum Water Level and Level Detection features are usable.

This function will affect the output speed only when setting Q5-01 > 0 to enable Suction Pressure Control will and setting Q5-20 to 1 to enable Suction Pressure Speed Control.

In all other cases, only Sleep at Minimum Suction Pressure and Pressure Detection features are usable.

- Note:**
1. This function is available in drive software versions PRG: 8552 and later.
  2. Not available in drive models 4A0930 and 4A1200.

## ■ Related Parameters

No.	Parameter Name	Setting Values
Q4-20	Water Level Speed Control	Default: 1 Range: 0, 1
Q5-20	Suction Pressure Speed Control	Default: 1 Range: 0, 1

## 4.6 iQpump Presets and Functions

### ◆ Delta Data Entry

Delta Data Entry allows the user to set the Low and High Feedback Detection Levels relative to the current setpoint and establish a PI setpoint when PID is not active.

- Note:**
1. This function is available in drive software versions PRG: 8552 and later.
  2. Not available in drive models 4A0930 and 4A1200.

Parameter/Condition	Delta Entry	Absolute Entry	Range Display (Toggles Automatically)
P1-04 Start Draw Down Level PID Direct-acting	-0.0 to -999.9	0.0 to 999.9	(0.0 to 999.9) <- -> “-Sub frm SetPt”
P1-04 Start Draw Down Level PID Inverse-acting	+0.0 to +999.9	0.0 to 999.9	(0.0 to 999.9) <- -> “+Add to SetPt”
P1-08 Low Feedback Level	-0.0 to -999.9	0.0 to 999.9	(0.0 to 999.9) <- -> “-Sub frm SetPt”
P1-11 High Feedback Level	+0.0 to +999.9	0.0 to 999.9	(0.0 to 999.9) <- -> “+Add to SetPt”

The following conditions will change the setpoint in order of priority when the drive is a non-PID mode or when PID is disabled:

The default Setpoint is Q1-01 (Setpoint 1)

1. Setpoints Q1-02 to Q1-04 when Multi-setpoint Digital Inputs are active (H1-□□ = 8D, 8E, 83, 84, or 85)
2. MEMOBUS Setpoint when MEMOBUS PID Setpoint enable bit is set
3. Pulse Input RP when H6-01 = 2 (PID Setpoint)
4. Analog Input when H3-□□ = C (PID Setpoint).

### ■ Related Parameters

No.	Parameter Name	Setting Values
P1-04	Start / Draw Down Level	Default: 0.0 Range: 0.0 to 999.9
P1-08	Low Feedback Level	Default: 0.0 Range: 0.0 to 999.9
P1-11	High Feedback Level	Default: 155.0 Range: 0.0 to 999.9



## ◆ Current Limit

This function provides a current limit of the pump (motor). The function is designed to prevent long-term overload conditions of the pump, especially if the motor and drive are oversized compared to the pump. The drive will attempt to limit the output current by reducing the frequency reference. The frequency is reduced using an internal current PI regulator. When the Current Limit function is active, the alarm "Current Limit Foldback" will be displayed on the HOA keypad. This function will only operate correctly when the drive is connected to a variable torque motor load such as a centrifugal pump. More specifically, it will only operate if the load is such that output current increases as output frequency increases (and vice-versa). The current limit function reduces the pump speed to just above the lower value between the minimum pump speed (P1-06) or the minimum output frequency. If PI mode is enabled (b5-01 > 0), a special limit will be applied to the PID integrator when output current limit is active to prevent integrator wind-up.

### ■ Start Up Procedure

1. Set all other parameters required for the application such as PI control loop, sleep, motor, and I/O parameters
2. Turn on the current limit function by setting Q3-01 to 1 (enabled). The default setting is 0 (disabled).
3. Set the desired current limit in Q3-02. This value should not exceed the motor, pump or drive's ratings. This does not in any way change the motor (oL1) and inverter (oL2) overload functions.
4. If desired, program a multi-function digital output (H2-□□) to 89 (Output Current Limit) to annunciate the alarm.

### ■ Related Parameters

No.	Parameter Name	Setting Values
Q3-01	Output Current Limit Select	Default: 0 Range: 0, 1
Q3-02	Current Limit	Default: 0.0 A Minimum: 0.0 Maximum: 1000.0

H2 Multi-Function Digital Output Settings		
H2-□□ Setting	Function	Description
89	Output 1 Limit	Closed: Drive output speed is being limited due to the output current limit or the single phase foldback regulator.

The drive displays an alarm on the keypad when the drive is in output current limit.

HOA Keypad Display	Minor Fault Name
Current Limit Foldback	Current Limit Foldback
Cause	Possible Solution
Drive output speed is being limited due to the output current limit.	<ul style="list-style-type: none"> <li>• Reduce the load.</li> <li>• Verify setting of Q3-02.</li> <li>• Change to a larger drive size.</li> </ul>

### ◆ Vertical Turbine Controller (VTC)

Vertical turbine pumps are typically used when water needs to be pumped from deep-water wells or open bodies of water such as rivers, lakes, irrigation canals, lifting stations, and water storage facilities. The VTC Application Preset allows the operator to easily setup control for a wide range of pumping applications. The drive will automatically adjust pump-operating conditions from Simplex (one pump on the drive) to multiple lag pumps as the process variables change. Control can be extended from simple pressure regulation to adding suction and vacuum control as well.

#### ■ Required Control Wiring

Most pressure transducers have current-based feedback (4 - 20 mA). The drive A2 terminal is pre-set for 4-20 mA and pre-programmed for PI feedback (H3-10 = B). If the sensor is voltage based (0-10 V) and terminal A3 is unused, then wire the transducer to terminal A3 and program H3-10 to F (A2 not used) and H3-06 to B (A3 PI Feedback).

When using lag pumps, the lag pump on/off control must be wired to the drive digital output terminals. The figure below shows the drive with the pressure transducer wired into terminal A2 and 3 lag pumps wired into output relays.

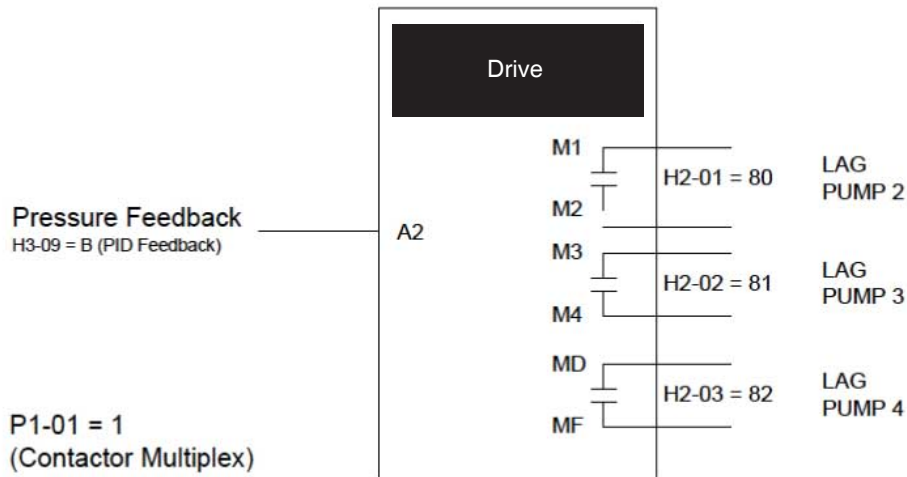

#### ■ Start Up Procedure for Drive with Three Lag Pumps

1. Set parameter A1-03 to 6011 (VTC Pressure Control). This will preset parameter values for this application.
2. Set the motor-rated current in parameter E2-01. This information can be found on the motor nameplate or specification sheet.
3. Set the number of motor poles in parameter E2-04 (2-pole motors have a rated RPM of slightly less than 3600 RPM; 4-pole motors have a rated RPM of slightly less than 1800 RPM). This information can be found on the motor nameplate or specification sheet.
4. Set the feedback device scaling in parameter P1-03. Check the sensor nameplate or specification sheet. For example, if the device outputs 20 mA at 100.0 PSI of pressure, then set P1-03 to 100.0 PSI. The drive controller will automatically scale all associated parameters and monitors. Monitor U1-91 (Pump Feedback) will display the measured pressure in PSI. The drive has a High Feedback Fault set in parameter P1-11. Make sure that P1-11 is appropriately set for sensor scaling in P1-03.
5. Set the desired pressure setpoint in parameter Q1-01 (PI setpoint). This is desired pressure that the drive will regulate the pump to control around. To quickly access this parameter, press the HOME key and then the ENTER key. The U1-99 monitor on the home screen displays the Q1-01 PI setpoint.
6. Set the minimum speed that the pump can be run in parameter P1-06. The default is 35 Hz. This information can be found on the pump specification sheet.
7. The default setting is for the drive to control the pump motor wired to the drive. Additional Lag pumps can be added to the system by wiring the on/off switch of the lag-pump motor to the drive as shown in the figure above. Set parameter P1-01 to 1 (Contactor Lag). This will enable the multiplexing control for multiple pumps
8. Set the number of additional lag pumps in parameter P3-00. For example, for a system with the drive pump and 3 additional lag pumps, set P3-00 to 3.
9. Set each lag pump's shutdown (stage off) level in Parameters P3-50, P3-60 and P3-70. The value is set in Hz. The setting tells the drive controller to de-stage the lag pump if the output frequency drops below this level. This setting needs to be coordinated with minimum pump speed (P1-06) and the sleep level. It is important that all lag pumps be de-staged above the sleep level or the drive will not enter sleep mode

10. The drive will stage lag pumps on based on the output frequency of the drive. At start, only the drive pump will be running. If the drive output frequency reaches 60 Hz for the time set in P3-05 and the pressure setpoint cannot be met, the drive will stage on (turn on) one of the lag pumps. The drive will stage on additional lag pumps until the pressure setpoint can be achieved.
11. The drive will stage lag pumps off based on the output frequency of the drive. Assume the system has been running with multiple lag pumps on. Now the demand starts to drop. The drive's output frequency will drop. If the output frequency falls below a lag pump frequency shutdown level for the time set in P3-09, the pump is de-staged. The drive will continue to de-stage pumps until the pressure setpoint can be met
12. Configure the sleep function. The drive can be programmed to shut off or sleep if the pressure stays at or above the Q1-01 setpoint with all lag pumps de-staged and the drive running at the minimum pump speed. In order to turn on the sleep function, set parameter P1-04 (Start – Draw Down Level) to a level slightly less than the pressure Q1-01 setpoint. When the drive is sleeping and the system pressure drops below the P1-04 setting, the drive will wake up and begin regulating pressure again. By sleeping, the drive will save energy and mechanical wear. A setting of zero in P1-04 will disable the sleep function (default setting).
13. Press the AUTO key to start the drive with PI control (pressure control). Press the OFF key to stop the drive
14. The pump can be run in a Hand (local) mode for maintenance purposes by pressing the HAND key while the drive is stopped. The HAND key acts as a start button. Press the OFF button to stop the drive. Press AUTO to return the drive to PI control. The HAND frequency reference is preset to 6 Hz in parameter P5-02. Disable the HAND key by setting P5-04 = 0 (disabled).

■ Related Parameters

No.	Parameter Name	Setting Values
A1-03	Initialize Parameters	Default: 0 Range: 0 to 5550; 6008 to 6014; 7770, 7771
E2-01	Motor Rated Current	Default: Min.: 10% of drive rated current Max.: 200% of drive rated current
E2-04	Number of Motor Poles	Default: 2 Min.: 2 Max.: 48
H3-06	Terminal A3 Function Selection	Default: 20 Range: 0 to 32
H3-10	Terminal A2 Function Selection	Default: B Range: 0 to 32
P1-01	Pump Mode	Default: 0 Range: 0, 1, 3
P1-03	Feedback Device Scaling	Default: 145.0 PSI Min.: 0.1 Max.: 6000.0
P1-04	Start / Draw Down Level	Default: 0.0 Min.: -999.9 Max.: 999.9
P1-06	Minimum Pump Speed	Default: 40.0 Hz Min.: 0.0 Max.: [E1-04]
P1-11	High Feedback Level	Default: 0.0 PSI Min.: 0.0 Max.: 6000.0
P3-00	Number of Lag Pumps	Default: 1 Min.: 1 Max.: 5
P3-05	Add Pump Delay Time	Default: 2 s Min.: 0 Max.: 3600
P3-09	Shutdown Pump Delay Time	Default: 5 s Min.: 0 Max.: 3600

## 4.6 iQpump Presets and Functions

No.	Parameter Name	Setting Values
P3-50	Pump 2 Frequency Shutdown Level	Default: 40.0 Hz Min.: 0.0 Max.: 400.0
P3-60	Pump 3 Frequency Shutdown Level	Default: 40.0 Hz Min.: 0.0 Max.: 400.0
P3-70	Pump 4 Frequency Shutdown Level	Default: 40.0 Hz Min.: 0.0 Max.: 400.0
P5-02	HAND Reference	Default: 40.0 Hz Min.: 0 Max.: [E1-04]
P5-04	HAND Key Function Selection	Default: 1 Range: 0, 1
Q1-01	PID Controller Setpoint 1	Default: 0.0 Min.: 0.0 Max.: 6000.0
U1-91	Pump Feedback	No signal output available
U1-99	Anti-No-Flow Timer	No signal output available

## ◆ Pre-Charge Function with One Lag Pump

The pre-charge function is designed to start a pumping system in a controlled manner. Rather than turning on the PI loop immediately at start up, the pre-charge function operates at a fixed speed to pre-fill the piping or storage tank before switching to PID control. This prevents the PI loop integrator from building up unnecessarily and also allows for a soft pressurization and fill of the system.

When an “auto” run command is issued or when waking up from the sleep state, the drive will check to see if it should perform a pre-charge operation. If so, it will ramp up and run at the pre-charge frequency. Some of the pump protective functions are disabled during pre-charge operation.

The drive will exit the pre-charge function when any of the below conditions are met:

- The process feedback level reaches the pre-charge level (P4-01)
- A multi-function digital input programmed for a Low Water Level switch deactivates (H1-□□ = 8F)
- The pre-charge timer expires (P4-03).

### ■ Required Control Wiring

No control wiring is required. An optional Low Water Level switch can be used to turn off the pre-charge function. Wire the switch into one of the drive digital inputs and program the corresponding H1-□□ parameter to 8F (the switch is normally open and closes during low water level).

### ■ Start Up Procedure

1. Set all other parameters required for the application such as PI control loop, sleep, motor, and I/O parameters. However, this function can be used in conjunction across a wide range of applications using a PI control process loop.
2. Set the pre-charge level in parameter (P4-01). This is the process feedback level (PSI, depth, etc.) that must be achieved before the pre-charge function will turn off.
3. Set the pre-charge frequency reference in parameter P2-02. This is the frequency that the drive will run at during pre-charge. Set this value to reasonable speed that is above the minimum pump speed (P1-06) and close to the average running frequency of the drive controller.
4. Set the pre-charge timer in P4-03. When the drive goes into pre-charge mode, no low-water switch is wired to the drive, and if the pre-charge level (P4-01) cannot be obtained, the drive will exit the pre-charge function after the P4-03 time and begin normal PI control
5. A multi-function digital input can be wired to and programmed for Pre-charge Disable if required (H1-□□ = 8C). Parameter P1-30 configures the switch type (0: Normally Open, 1: Normally Closed).
6. A multi-function digital output can be wired to and programmed to close whenever the pre-charge function is active (H2-□□ = A4).

### ■ Conditions for Entering Pre-charge Mode

- Drive Ready or Sleeping (run command, not faulted, not in program mode).
- NOT in HAND Mode
- “Disable Pre-Charge” digital input NOT closed.
- Pre-charge time set greater than zero (P4-03 > 0)
- If the Pre-charge level is greater than zero (P4-01 > 0) and the PID feedback is below the P4-01 level (Forward acting PID, b5-09 = 0).
- If the Pre-charge level is greater than zero (P4-01 > 0) and the PID feedback is above the P4-01 level (Reverse acting PID, b5-09 = 1).

### ■ Operation During Pre-Charge Mode

- Drive will run at the Pre-Charge frequency (P4-02).
- The PID controller is disabled.
- The HOA keypad will display the message “Pre Chg Mode – Pre-chg Active”.
- The pre-charge digital output (H2-0□ = A4) will close
- If the Pre-Charge frequency (P4-02) is set less than minimum pump speed (P1-06), an alarm “Freq. Ref < Pump Min P1-06” will be displayed and the drive will run at the minimum pump speed.

### ■ Conditions for Exiting the Pre-Charge Mode

- When Pre-Charge timer expires (P4-03). The drive will always exit after the pre-charge timer expires.

## 4.6 iQpump Presets and Functions

- When the “Disable Pre-Charge” digital input (H1-□□ = 8C) is closed, even momentarily
- When the PID feedback satisfies Pre-Charge level (P4-01):  
 Feedback is greater than Pre-Charge Level (P4-01) (forward-acting PID, b5-09 = 0)  
 Feedback is less than Pre-Charge Level (P4-01) (reverse-acting PID, b5-09 = 1)
- When the “Low Water” digital input (H1-□□ = 8C) deactivates. A digital input must be programmed to “Low Water” (H1-0□ = 8F). The input is configured in P1-30 (0: normally open, 1: normally closed).

### ■ Related Parameters

No.	Parameter Name	Setting Values
P4-01	Pre-Charge Level	Default: 0.0 PSI Minimum: 0.0 Maximum: 6000.0
P4-02	Pre-Charge Frequency	Default: 0.0 Hz Minimum: 0.0 Maximum: [E1-04]
P4-03	Pre-Charge Time	Default: 0.0 min Minimum: 0.0 Maximum: 3600.0
P4-05	Pre-Charge Loss of Prime Level	Default: 0.0 A Minimum: 0.0 Maximum: 1000.0
P4-06	Pre-Charge Frequency 2	Default: 0.0 Hz Minimum: 0.0 Maximum: [E1-04]
P4-07	Pre-Charge Time 2	Default: 0.0 min Minimum: 0.0 Maximum: 3600.0
P4-08	Pre-Charge Loss of Prime Level 2	Default: 0.0 A Minimum: 0.0 Maximum: 1000.0

#### H1 Multi-Function Digital Input Settings

H1-□□ Setting	Function	Description
8C	Disable Pre-Charge	Closed: Pre-Charge disabled.

#### H2 Multi-Function Digital Output Settings

H2-□□ Setting	Function	Description
A4	Pre-Charge	Closed: Drive is in Pre-Charge mode.

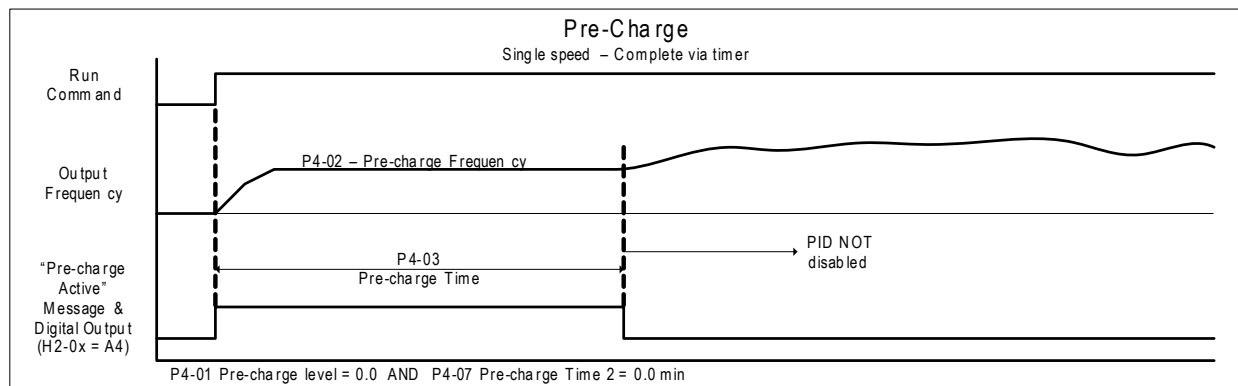

Figure 4.13 Pre-Charge Single Speed Complete via Timer

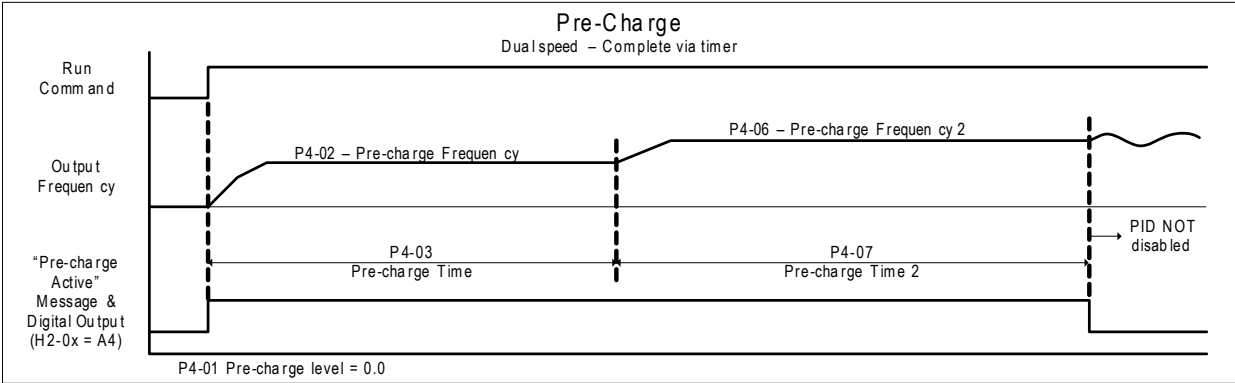

Figure 4.14 Pre-Charge Dual Speed Complete via Timer

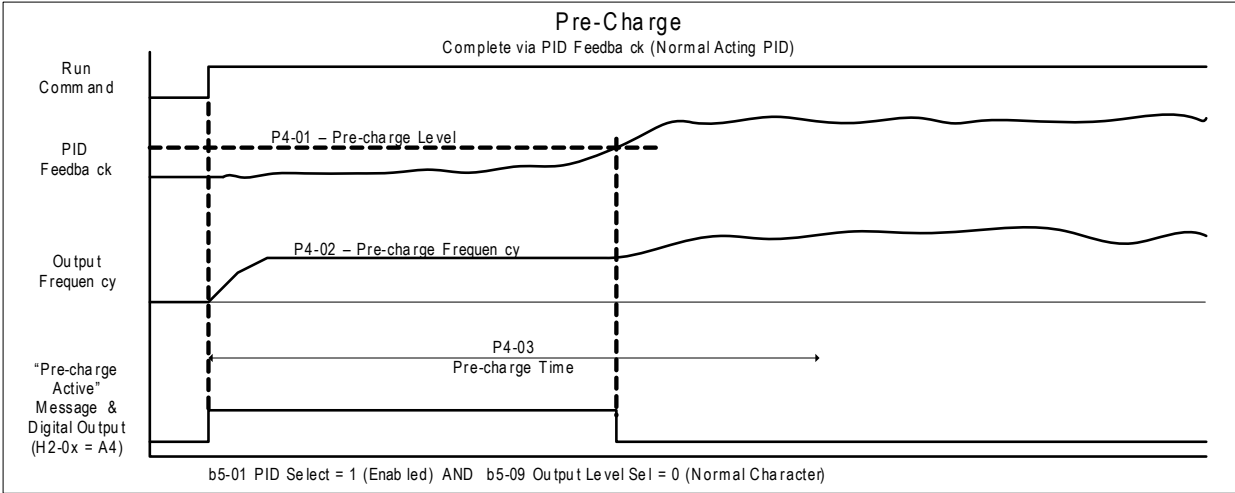

Figure 4.15 Pre-Charge Complete via Normal PID Feedback

### ◆ Setpoint Boost after Lag Pump De-staging

When a lag pump is de-staged (turned off), there can be a sudden drop in pressure in the system due to the pump de-staging. The Setpoint Boost function will dampen the shock load (pressure dip) to the system by temporarily raising the PI setpoint of the drive controller during de-staging.

The function will raise the setpoint to the measured feedback value at the time of de-staging for the time set in P3-11. When the P3-11 time expires, the setpoint will return to the Q1-01 value and the drive operates normally. The intention of the feature is to get the drive to begin accelerating as soon as a pump is de-staged, thus limiting the shock to the system since the PI controller would tell the drive to accelerate anyway in response the de-staged pump. It is not intended to regulate at the boosted setpoint for a long period of time.

- The maximum PI setpoint is limited to the Q1-01 setpoint plus the P3-10 (Max Boost at De-stage) setting.
- This feature cannot decrease the setpoint, therefore the function is disabled if b5-09 = 1 (inverse acting).
- If the iQpump controller calls for a lag pump to be staged during the P3-11 time, the staging will occur with the Setpoint Boost function being immediately disabled.
- Setting either P3-10 or P3-11 to zero disables the Setpoint Boost function.
- The PI control loop is active during Setpoint Boost.
- The default setting for P3-10 is 0.0 PSI and P3-11 is 5.0 sec.

While the setpoint is being controlled by the Setpoint Boost after De-stage function, the drive will display the message "Setpoint Boost Active (P3-11)."

### ■ Start Up Procedure

1. Set all other parameters required for the application such as PI control loop, sleep, motor, and I/O parameters. [Refer to Vertical Turbine Controller \(VTC\) on page 170](#) for an example. However, this function can be used in conjunction across a wide range of applications using a PI control process loop with multiple lag pumps that are staged and de-staged
2. Set the maximum Setpoint Boost in parameter (P3-10). This is set in the selected system units (PSI, etc.). When a de-staging occurs and Setpoint Boost is to occur, the PI feedback level temporarily becomes the PI setpoint. Parameter P3-10 limits how much the PI setpoint can be raised.
3. Set the Setpoint Boost time in parameter P3-11. This sets how long the Setpoint Boost function will boost the PI setpoint. After the P3-11 time expires, the PI setpoint will return to the Q1-01 setting.

### ■ Related Parameters

No.	Parameter Name	Setting Values
b5-09	PID Output Level Selection	Default: 0 Range: 0, 1
P3-10	Setpoint Boost Maximum at De-stage	Default: 0.0 PSI Minimum: -20.0 Maximum: 20.0
P3-11	Setpoint Boost after De-stage Time	Default: 5.0 s Minimum: 0.0 Maximum: 60.0
Q1-01	PID Controller Setpoint 1	Default: 0.0 Minimum: 0.0 Maximum: 6000.0



## ◆ Frequency Reduction after Lag Pump Staging

When a lag pump is staged (turned on), there can be a sudden increase in pressure in the system due to the pump staging on. The Frequency Reduction function will dampen the shock load (pressure spike) to the system by temporarily limiting (lowering) the drive controller output frequency during pump staging.

The function will limit the output frequency at time of de-staging for the time set in P3-07. When the P3-07 time expires, the frequency limit is removed and the drive operates normally. The intention of the feature is to get the drive to begin decelerating as soon as a pump is staged to limit the shock to the system, as the PI controller would tell the drive to decelerate in response the staged on pump. It is not intended to regulate at the limited output frequency for an extended period of time.

- Note:**
1. When a lag pump is staged on, the drive will upper-limit the output frequency for the P3-07 (Frequency Reduction Time) setting. The output frequency limit is determined by subtracting parameter P3-06 (Frequency Reduction at Staging) from parameter P3-03 (Max-Multi Level). The default setting for P3-03 is 59.0 Hz, P3-06 is 0.0 PSI, and P3-07 is 0.0 sec.
  2. The drive integrator will be limited to prevent wind-up and ensure a smooth transition back out of frequency limit.
  3. Once the P3-07 time expires, the upper-limit will be removed and the drive will operate normally.
  4. If the drive calls for de-staging a pump during the P3-07 time, the de-stage will be allowed to happen, and normal PI operation will immediately resume.
  5. If either P3-06 or P3-07 is set to zero, this feature will not operate.

While the output frequency is being controlled by the Frequency Reduction after Staging function, the drive will display the message "Freq Reduction Active (P3-07)."

## ■ Start Up Procedure

1. Set all other parameters required for the application such as PI control loop, sleep, motor, and I/O parameters. [Refer to Vertical Turbine Controller \(VTC\) on page 170](#) for an example. However, this function can be used in conjunction across a wide range of applications using a PI control process loop with multiple lag pumps that are staged and de-staged.
2. Set the amount of frequency reduction at staging in parameter P3-06. When a staging occurs, the output frequency is limited to P3-03 – P3-06.  
Example: If P3-03 = 59 Hz (default) and P3-06 is set to 5.0 Hz, the output frequency will be limited to 54 Hz.
3. Set the Frequency Reduction time at staging in parameter P3-07. This sets how long the output frequency will be limited during pump staging. After the P3-07 time expires, the PI controller will return to normal.

## ■ Related Parameters

No.	Parameter Name	Setting Values
b5-09	PID Output Level Selection	Default: 0 Range: 0, 1
P3-10	Setpoint Boost Maximum at De-Stage	Default: 0.0 PSI Minimum: -20.0 Maximum: 20.0
P3-11	Setpoint Boost after De-Stage Time	Default: 5.0 s Minimum: 0.0 Maximum: 60.0
Q1-01	PID Controller Setpoint 1	Default: 0.0 Minimum: 0.0 Maximum: 6000.0

### ◆ Using the DO-A3 Option for Additional Lag Pumps

The drive comes standard with three output relays capable of controlling three lag pumps. With the addition of a DO-A3 card installed in the drive, two additional lag pumps can be controlled bring the total to five lag pumps.

#### ■ Required Control Wiring

Install the DO-A3 option card on the CN5-A, CN5-B, or CN5-C option connector on the drive. Refer to the DO-A3 Installation Manual packaged with the option for installation and wiring instructions. The option card has two relay outputs on terminal block 1 (TB1) and 6 photocoupler outputs on terminal block 2 (TB2). the drive uses only the relay outputs on terminal block 1.

#### ■ Start Up Procedure for Controlling a Lead Pump plus Five Lag Pumps

1. Install and wire the DO-A3 as indicated in the option installation manual.
2. Set all other parameters required for the application such as PI control loop, sleep, motor, and I/O parameters.
3. Program drive parameters with the values shown in [Table 4.7](#) to correctly control each lag pump.

**Table 4.7 Lag Pump Settings**

Lag Pump Number	Terminal Location	Terminal Numbers	Parameter	Setting
1	Control Board	M1-M2	H2-01	80
2		M3-M4	H2-02	81
3		MD-MF	H2-03	82
4	DO-A3 Option	M1-M2	F5-07	83
5		M3-M4	F5-08	84

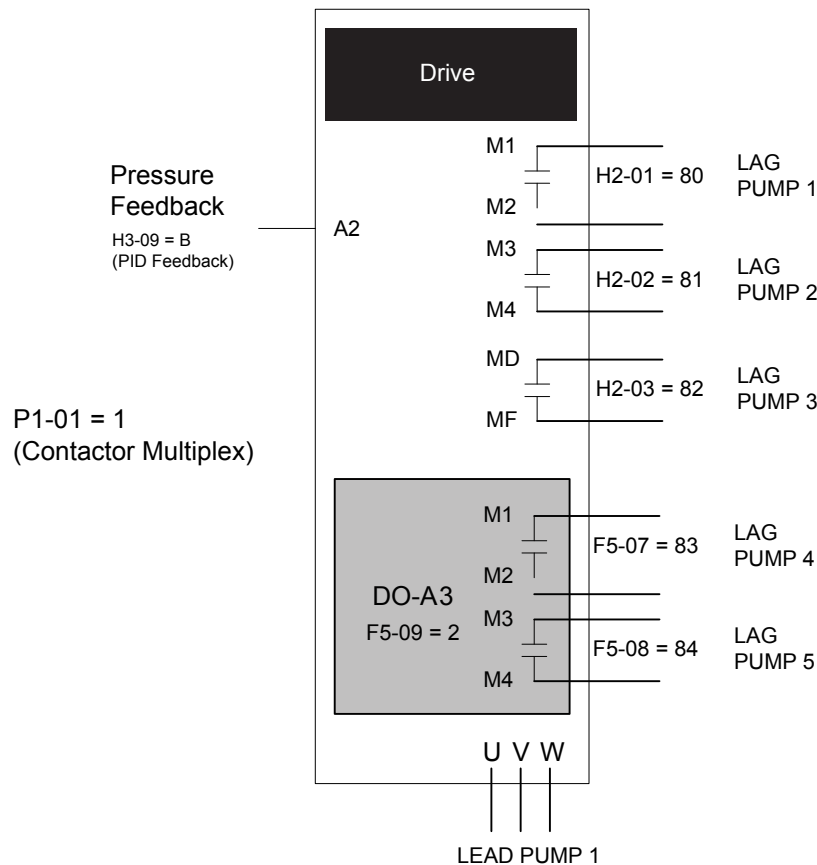

**Figure 4.16 Controlling Five Lag Pumps with DO-A3 Option**

## ◆ MEMOBUS Multiplexing Setup

### ■ Wiring the Drive RS-485 Network Connections

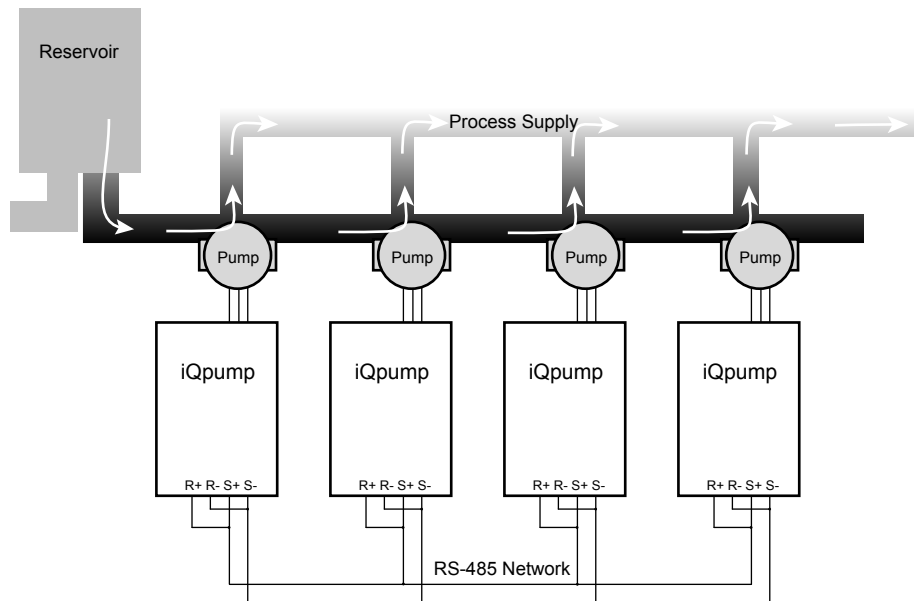

Figure 4.17 System Overview

Perform the following steps to make the RS-485 network connections between all drives that will be multiplexed:

1. Jumper terminals (R+ to S+) and jumper terminals (R- to S-) terminals on each individual drive according to [Figure 4.18](#).

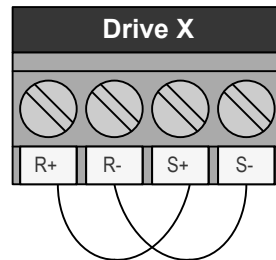

Figure 4.18 Drive Terminal Jumpers

2. Use shielded communication cable for steps 3 and 4 to connect the drives in a daisy chain manner according to [Figure 4.19](#).
3. Daisy chain the (R+ to S+) terminals between each drive.
4. Daisy chain the (R- to S-) terminals between each drive.

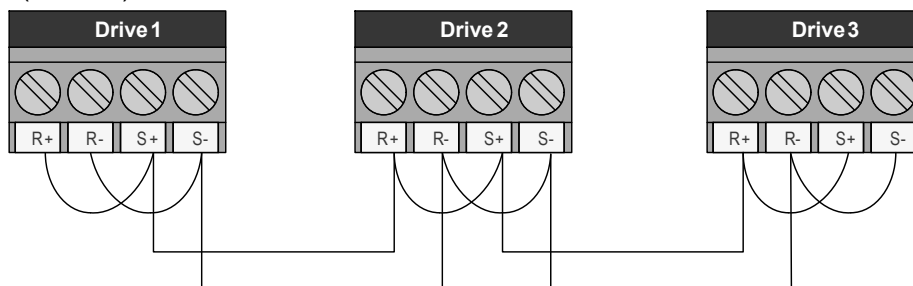

Figure 4.19 Daisy Chain Three Drives

## 4.6 iQpump Presets and Functions

### ■ Setting the Drive Networking Parameters

1. Set parameter H5-01, Serial Node Address, on each drive.

**Note:** For optimal performance, use consecutive numbers starting from 1. Parameter setting H5-01 must be unique for each drive.

2. Set parameter P9-25, Highest Node Address, on each drive.

**Note:** For optimal performance, set to highest H5-01 value. This setting must be the same for all the drives on the network.

3. Set P1-01 to 3 (MEMOBUS/Modbus Network) on all the drives.

4. Cycle main power to all networked drives.

**Note:** The H5-01 setting will not take effect until power is cycled to the drive and may cause communication errors and unexpected behavior.

### ■ Verifying Drive Network Communications

Access monitor U9-02, Network Activity, and verify:

- No drives have a value of 0 <->
- All drives are receiving valid data indicated by a regular change in the monitor value.
- At least one drive has the unit <M>, while the others have the unit <+>.

**Note:** Set parameter P9-98. [Refer to MEMOBUS Multiplexing System-wide Parameter Entry on page 191](#) for details.

**Table 4.8 Network Connectivity Information**

Network State	Top Line on Home Screen (o1-12 = 1)	U9-02 Network Activity
Drive is the Master and is communicating with another drive.	<pre> &lt;M&gt; CONNECTED Pump Off Network U5-99= 100.0PSI U1-02= 0.00Hz LSEQ U1-91= 62.8PSI LREF &lt;- MONITOR -&gt;           </pre>	<pre> - MONITR -      DRV RDY Network Activity U9-02= 9453&lt;M&gt; U1-02= 0.00Hz LSEQ U1-91= 62.8PSI LREF Home          FWD           </pre>
Drive is a node on the network and is communicating with a Master.	<pre> &lt;+&gt; CONNECTED Pump Off Network U5-99= 100.0PSI U1-02= 0.00Hz LSEQ U1-91= 62.8PSI LREF &lt;- MONITOR -&gt;           </pre>	<pre> - MONITR -      DRV RDY Network Activity U9-02= 324&lt;+&gt; U1-02= 0.00Hz LSEQ U1-91= 62.8PSI LREF Home          FWD           </pre>
Drive is not able to communicate to any other drives.	<pre> &lt;-&gt; DISCONNECTED Pump Off Network U5-99= 100.0PSI U1-02= 0.00Hz LSEQ U1-91= 62.8PSI LREF &lt;- MONITOR -&gt;           </pre>	<pre> - MONITR -      DRV RDY Network Activity U9-02= 0&lt;-&gt; U1-02= 0.00Hz LSEQ U1-91= 62.8PSI LREF Home          FWD           </pre>

If a drive displays U9-02 = 0 <->:

- Check physical connections.
- Verify the H5-□□ serial communication settings.
- Confirm the P9-25 and P9-27 settings on all the drives. P9-25 should be set to the highest H5-01 address and at least one drive should have P9-27 set to 0.
- Cycle main power.

### ■ Multiplexing Principle

Always observed by system:

- New drives start as Lead and run in PI mode.

- Only the Lead drive can request staging and de-staging.
- Staging will start a new Lead drive and make the old Lead drive into a Lag drive.
- De-staging will stop the current Lead drive and restore the previous drive as the Lead drive.

**■ Multiplexing Messages**

During multiplexing, the drive will display a message when it will be staged in or de-staged out. The message will indicate if it is being staged in or out and display a countdown timer of how long until the change takes place.

One of the following conditions must be met for de-staging to occur:

- High Feedback Quick De-stage
- Low Feedback Quick De-stage
- Normal De-stage
- Low Water Level De-stage
- Suction Pressure De-stage

**■ Drive Run Order**

U9-04, Running Queue No:

- Shows the position in the iQpump MEMOBUS running queue.
- U9-04 = 0 for pumps that are not running.
- U9-04 = 1 on the first pump that came on and is still running.
- U9-04 = 2 on the second pump that came on and is still running.
- U9-04 = the number of pumps running for the current Lead drive.

**■ Multiplex Status Display**

Table 4.9 Multiplex Status Display

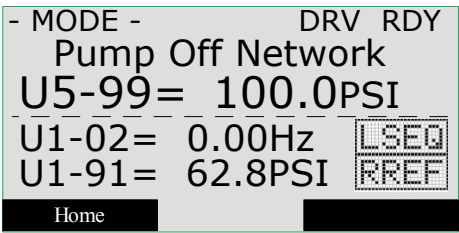
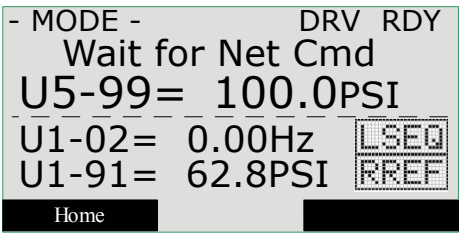
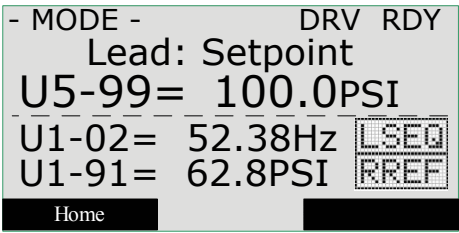
Network State	Display
<p>Drive is not able to accept commands from the iQpump MEMOBUS network because the drive is not in AUTO Mode run.</p>	
<p>Drive is in AUTO Mode and waiting for a run command from the iQpump MEMOBUS network.</p>	
<p>Drive is in AUTO Mode, Lead operation and is currently regulating the system using PI control.</p>	

## 4.6 iQpump Presets and Functions

Network State	Display
Drive is in Auto Mode, Lag operation and is holding the speed at the time it made the switch from being a lead drive to a lag. Speed is held until P9-07 time expires. The Home screen will display U1-01 instead of U5-99.	<pre> - MODE -          DRV RDY   Lag: Fixed Hold U1-01= 59.41HZ U1-02= 59.41HZ  LSEQ U1-91= 99.8PSI  RREF Home </pre>
Drive is in Auto Mode, Lag operation and is running at the speed set in P9-06. The Home Screen will display U1-01 instead of U5-99.	<pre> - MODE -          DRV RDY   Lag: Fixed P9-06 U1-01= 55.00HZ U1-02= 55.00HZ  LSEQ U1-91= 99.9PSI  RREF Home </pre>
Drive is in AUTO Mode, Lag operation and is following the speed of the current Lead drive. The Home screen will display U1-01 instead of U5-99.	<pre> - MODE -          DRV RDY   Lag: Follow Lead U1-01= 51.37HZ U1-02= 51.35HZ  LSEQ U1-91= 98.9PSI  RREF Home </pre>
Drive is in AUTO Mode, Lead operation with Geothermal Enabled. The Home screen will display U1-01 instead of U5-99	<pre> - MODE -          DRV RDY   Lead: Geothermal U1-01= 48.00HZ U1-02= 44.82Hz  LSEQ U1-80= 83.6°F   RREF Home </pre>

### ■ PI Feedback via Network

The Network PI Feedback comes from a drive on the network with a valid analog PI feedback source and can be used as the primary or secondary feedback source for a networked drive.

Set P9-02 to 0 if a drive has an analog PI feedback device installed and switching to network as a backup is not desired.

if a drive has an analog PI feedback device installed and the network PI feedback is considered as a backup, set P9-02 to 1 for no alarm message when switched and set P9-02 to 2 for an alarm.

Set P9-02 to 3 if a drive has no analog PI feedback device installed and relies solely on the analog PI feedback of another networked drive.

**Note:** Connect an analog PI feedback device to each drive for best performance.

### ■ Related Parameters

No.	Parameter Name	Setting Values
H5-01	Drive Node Address	Default: 1F (Hex) Min.: 0 Max.: FF
P1-01	Pump Mode	Default: 0 Range: 0, 1, 3
P9-02	Feedback Source	Default: 0 Range: 0 to 3

No.	Parameter Name	Setting Values
P9-25	Highest Node Address	Default: 08h Min.: 02h Max.: 08h
P9-27	Network Recovery	Default: 0 Range: 0 to 3
U9-02	Network Activity	No signal output available
U9-04	Running Queue Number	No signal output available

## ◆ MEMOBUS Multiplexing Application Examples

### ■ Simple Duplex System Application Example

A customer requires a duplex system with the following capabilities:

- Control the system pressure using two drives (no PLCs).
- Alternate drives everyday to even out the pump wear.
- Toggle switch for Run command.
- Each drive will have its own feedback transducer. Due to the shut-off valves, the network feedback should not be used as a backup.
- Pump is at optimal running speed when at fixed speed of 54.0 Hz.
- Setpoint is 100 PSI, feedback scale is 145 PSI, start level is 80 PSI.

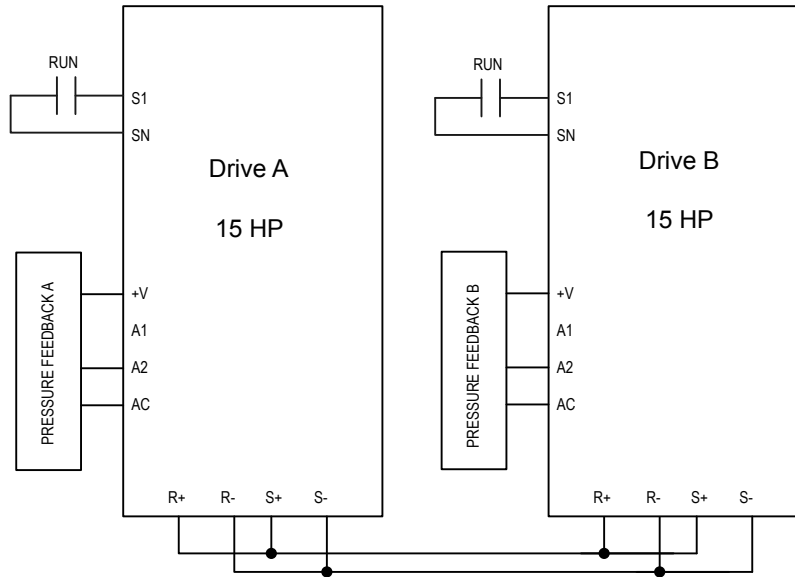

Figure 4.20 Simplified Wiring Diagram

Table 4.10 Related Parameters for Simple Duplex System Example

Description	Drive A <1>	Drive B <1>
Run Source: 1 (Terminals)	b1-02 = 1	b1-02 = 1
Node Address	H5-01 = 1	H5-01 = 2
Highest Node Address	P9-25 = 2	P9-25 = 2
Pump Mode: 3 (Network)	P1-01 = 3	P1-01 = 3
Feedback Source: 0 (Analog)	P9-02 = 0	P9-02 = 0
Lag Fixed Speed	P9-06 = 54.0 Hz	P9-06 = 54.0 Hz
Setpoint	U5-99 = 100 PSI	U5-99 = 100 PSI
Start Level	P1-04 = 80 PSI	P1-04 = 80 PSI

<1> All other multiplexing and alternation parameters are set to default settings.

### ■ Duplex System with Fine Tuning Application Example

The customer would like to solve a pump cycling problem. Currently the second drive runs for 10 to 20 seconds at minimum speed then shuts off, letting the first drive run at maximum. This will then run the second drive again and the cycle will repeat. The customer must also account for system losses when running both pumps by boosting the setpoint by 5 PSI. In the event that the pressure exceeds 125 PSI, the second drive should de-stage if both drives are running. If the pressure exceeds 140 PSI, a high feedback fault should occur and stop the drive.

There are multiple methods to handle the pump cycling problem:

- Lower the lag fixed speed (P9-06)
- Decrease the lag fixed speed delay (P9-07)
- Increase the staging frequency level (P9-09)
- Increase the staging delay time (P9-11)



- Increase the de-staging delay time (P9-15)
- Increase the stabilization time (P9-16)
- Increase both the Add Freq Level and Add Dly Time

**Table 4.11 Related Parameters for Duplex System with Fine Tuning Application Example**

Description	Drive A <f>	Drive B <f>
Run Source: 1 (Terminals)	b1-02 = 1	b1-02 = 1
Node Address	H5-01 = 1	H5-01 = 2
Highest Node Address	P9-25 = 2	P9-25 = 2
Pump Mode: 3 (Network)	P1-01 = 3	P1-01 = 3
Feedback Source: 0 (Analog)	P9-02 = 0	P9-02 = 0
Lag Fixed Speed	P9-06 = 54.0 Hz	P9-06 = 54.0 Hz
Setpoint	U5-99 = 100 PSI	U5-99 = 100 PSI
Start Level	P1-04 = 140 PSI	P1-04 = 140 PSI
High Feedback Quick De-Stage	P9-18 = 89.3%	P9-18 = 89.3%
Setpoint Modifier	P9-17 = 5.0 PSI	P9-17 = 5.0 PSI
Add Drive Frequency Level	P9-09 = 59.0 Hz	P9-09 = 59.0 Hz
Add Drive Delay	P9-11 = 12.0 s	P9-11 = 12.0 s

<f> All other multiplexing and alternation parameters are set to default settings.

### ■ Duplex System with Jockey Pump Example

A customer requires a pump system with the following requirements:

- One small pump (the Jockey pump) will run the system during off-peak times.
- Two larger pumps will run the system when the demand is higher.
- The Jockey pump should not run when the two larger pumps are running.
- Pump wear is still an issue, but it is expected that the small pump will run longer hours and will always run first after a loss of power.
- The feedback scale is 145 PSI.
- There is only one feedback transducer in the system.

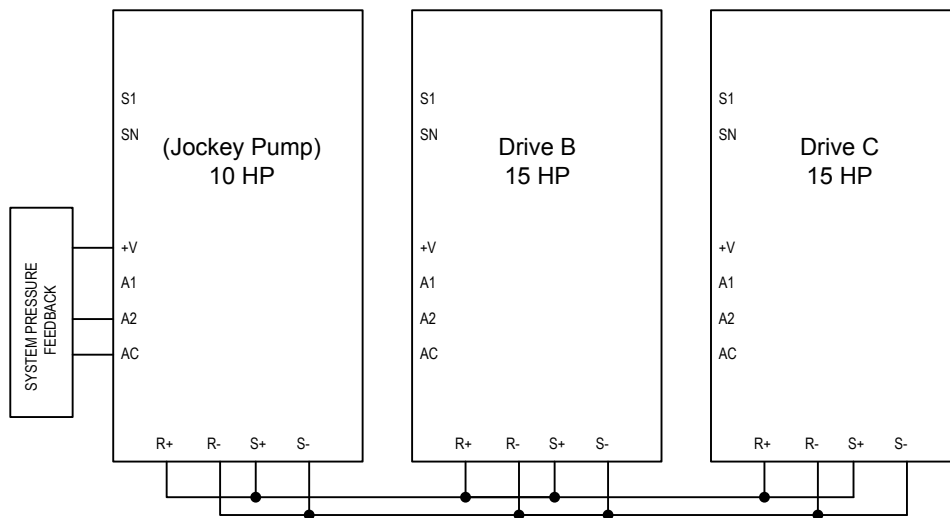

**Figure 4.21 Simplified Wiring Diagram**

**Table 4.12 Related Parameters for Duplex System with Jockey Pump Example**

Description	Jockey Pump <f>	Drive B <f>	Drive C <f>
Node Address	H5-01 = 1	H5-01 = 2	H5-01 = 3
Highest Node Address	P9-25 = 3	P9-25 = 3	P9-25 = 3
Pump Mode: 3 (Network)	P1-01 = 3	P1-01 = 3	P1-01 = 3
Feedback Source: 0 (Analog), 3 (Network)	P9-02 = 0	P9-02 = 3	P9-02 = 3

## 4.6 iQpump Presets and Functions

Description	Jockey Pump <1>	Drive B <1>	Drive C <1>
Lag Drive Speed: 0 (Always), 2 (Turn Off)	P9-05 = 2	P9-05 = 0	P9-05 = 0
Allow Net Run: 0 (Always), 2 (First Only)	P9-20 = 2	P9-20 = 0	P9-20 = 0
Run Priority	P9-21 = 7	P9-21 = 8	P9-21 = 8
Lead Swap @ Sleep	P9-24 = 0	P9-24 = 1200 s	P9-24 = 1200 s
Setpoint	U5-99 = 100 PSI	U5-99 = 100 PSI	U5-99 = 100 PSI
Start Level	P1-04 = 80 PSI	P1-04 = 80 PSI	P1-04 = 80 PSI

<1> All other multiplexing and alternation parameters are set to default settings.

### ■ Triplex System Example

A customer who currently runs a duplex system would like to retrofit an existing triplex system with the following requirements:

- Three similarly sized pumps would run the system.
- A maximum of two drives should be running at any point; the third drive is a backup.
- Alternation should only happen when pumps are not running (sleeping).
- If one of the analog pressure feedback transducers should fail, read from a working one and notify the customer of the failure by the alarm display.
- Setpoint is 90 PSI, feedback scale is 145 PSI, start level is 75 PSI.

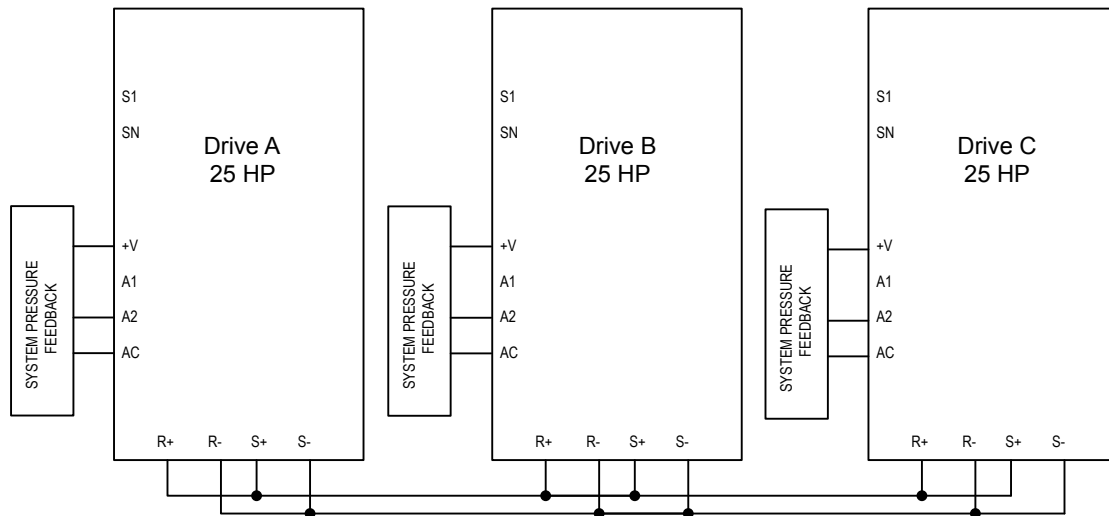

Figure 4.22 Simplified Wiring Diagram

Table 4.13 Related Parameters for Triplex System Example

Description	Drive A <1>	Drive B <1>	Drive C <1>
Node Address	H5-01 = 1	H5-01 = 2	H5-01 = 3
Highest Node Address	P9-25 = 3	P9-25 = 3	P9-25 = 3
Pump Mode: 3 (Network)	P1-01 = 3	P1-01 = 3	P1-01 = 3
Feedback Source: 2 (Analog ->Net, with Alarm)	P9-02 = 2	P9-02 = 2	P9-02 = 2
Alternation Mode: 3 (FIFO @ Sleep)	P9-04 = 3	P9-04 = 3	P9-04 = 3
Maximum Running Pumps	P9-23 = 2	P9-23 = 2	P9-23 = 2
Setpoint	U5-99 = 90 PSI	U5-99 = 90 PSI	U5-99 = 90 PSI
Start Level	P1-04 = 75 PSI	P1-04 = 75 PSI	P1-04 = 75 PSI

<1> All other multiplexing and alternation parameters are set to default settings.

## ◆ MEMOBUS Multiplexing Stop History

Many irrigation-pumping skids consist of a PM pump (Pressure Maintenance) and typically two larger booster pumps to maintain high flow peak demands. In many cases depending on the number of irrigation zones in combination with the type of sprinkler heads used, the flow demand fluctuates and may not require the use of both larger booster pumps at the same time until higher flow rates are required. The drive Controller "Run Stop" history ensures that both booster pumps alternate each run cycle.

**Table 4.14 P9-01, Lead Drive Selection, Detection Settings**

Setting	Description
0	Next Available Select next available drive on the network as the new lead drive
1	Lowest Runtime (default) Select the iQpump Controller with the lowest runtime as the new lead drive
2	Stop History Select the iQpump that had been stopped for the longest time.

**Note:** The new lead drive selection also applies to Alternation (P9-03 > 0) and will use the Stop History list when finding the alternate.

## ■ Triplex Irrigation Booster System Example

When pressure is dropping, the PM Pump (if installed) will attempt to return the system pressure to the desired setpoint level. If the PM Pump is not able to return the system to the setpoint pressure, typically due to a greater flow demand, the booster pump #1 will be staged on.

The drive controller will speed up or slow down the pump as needed to maintain the system pressure. When flow decreases and the pump system is no longer required to run, the system will go to sleep waiting for the pressure to drop. On the next run cycle the PM pump will start up again, and instead of running booster pump #1, booster pump #2 is staged on, since booster #1 ran during the last cycle.

This method ensures that during normal operation both booster pumps will operate evenly as lead or lag pumps each run cycle.

A triplex irrigation booster system has one PM Pump (pressure maintenance) and two larger booster pumps of the same horsepower. The customer would like to ensure that the PM Pump is also the lead pump to recharge the system during low flow usage, but during high demands the booster pumps alternate on each run cycle or if required will both run to support very high flow demands.

- Jockey/PM Pump will also be lead to start.
- Jockey/PM Pump will stage booster pump 1 or 2 and stay running for 20 seconds and then shut off.
- Booster pump 1 will run system and if required, call for booster pump 2 or vice versa.
- On sleep mode, the lead drive for starting will swap back to Jockey/PM Pump.
- System setpoint 100 PSI.
- Pressure drop of 10 PSI will start the Jockey pump.
- All drives have individual transducers rated 200 PSI maximum, but if there is a transducer failure, switch to network.

## ■ Triplex Irrigation Booster System Related Parameters

**Table 4.15 Related Parameters**

Parameter No.	Parameter Name	PM Pump	Booster Pump 1	Booster Pump 2
H5-01	Drive Node Address	1	2	3
P1-01	Pump Mode	3	3	3
P1-03	Feedback Device Scaling	200 PSI	200 PSI	200 PSI
P1-04	Start / Draw Down Level	-10.0 PSI	-10.0 PSI	-10.0 PSI
P9-01	Lead Drive Selection	2	2	2
P9-02	Feedback Source	2	2	2
P9-07	Lag Fixed Speed Delay	20 s	5 s	5 s
P9-20	Allow Network Run	2	0	0
P9-21	Run Priority	7	8	8
P9-24	Lead Swap at Sleep	0 s	1 s	1 s
P9-25	Highest Node Address	3	3	3
U5-99	PID Setpoint Command	100 PSI	100 PSI	100 PSI

### ◆ MEMOBUS Multiplexing Speed Follower Deceleration Time Switchover

The iQpump Speed Follower will attempt to match the speed of the Lead Drive after the Lag Drive Fixed Speed Delay.

Consider a scenario wherein the system needs help from an idle drive to maintain system pressure. When the idle drive is called to run, the difference between the set-point and the feedback may be too small to make the drive accelerate faster. In the case of a system is configured with these settings:

- Set for Lag Drive Speed Follower
- Add Pump method is Frequency Reference
- Frequency Reference setting close to the maximum frequency

The system will drop the speed after the Lag Drive Fixed Speed Delay expires in order to follow the output frequency of the previously idle drive. This transition may cause unwanted pressure drops. A longer deceleration time will be activated on the lag drives when the system switches the drive that is being followed. The longer deceleration time will be effective for a programmable setting, after which, the regular deceleration time is used.

#### ■ Functional Operation

If P9-05 = 3 (Follow Lead Spd), the lag drive will use the network information and the lead drive output speed as its frequency reference. The lag drive's final speed reference is affected by (Lag Follower Gain P9-30) and then by (Lag Follower Bias P9-31).

$$\text{Lag Drive Speed} = (\text{Lead Drive Speed} \times \text{Lag Follower Gain}) + \text{Lag Follower Bias}$$

When P9-33 > 0.0 sec, an alternate deceleration time (Lag Follower Decel P9-32) is used when the drive switches from the latched speed (Lag Fixed Delay P9-07) to the new Lead drive's output frequency. The deceleration time is active for the duration set in (Lag Followr Dtim P9-33), and will switch back to the regular deceleration rates when it expires.

**Note:** Parameter functionality stated below only applies when P1-01 = 3 (MEMOBUS Network)

#### ■ Related Parameters

No.	Name	Description	Values
P9-05	Lag Drive Mode	Determines the functionality of the lag drives. 0: Fixed speed. The drive runs at the P9-06 setting after the time set in P9-07 expires. 2: Turn off. The drive stops running when it switches to a lag drive after the time set in P9-07 expires. 3: Follow Lead Speed. The drive will follow the speed of the current lead drive, applying P9-30 gain and P9-31 bias.	Default: 0 Range: 0, 2, 3
P9-07	Lag Fixed Speed Delay	Specifies how long speed is latched before performing the function specified in P9-05 when the drive changes from a lead to a lag.	Default: 5 s Min.: 0 Max.: 1000
P9-30	Lag Drive Speed Follower Gain	Sets the gain to be applied to the speed of the current lead drive when P9-05 is set to 3. The bias to be applied is set in P9-31.	Default: 100.0% Min.: 0.0 Max.: 300.0
P9-31	Lag Drive Speed Follower Bias	Sets the bias to be applied to the speed of the current lead drive when P9-05 is set to 3. The gain to be applied is set in P9-30.	Default: 0.00 Hz Min.: -60.0 Max.: 60.0
P9-32	Lag Follower Deceleration Time	Sets the deceleration time when the P9-33 timer is running and the drive is running as Lag Drive Speed Follower (P9-05 is set to 3).	Default: 60.0 s Min.: 0.0 Max.: 1000.0
P9-33	Lag Follower Deceleration Time Active Time	Sets the time during which the deceleration time set in P9-32 is effective. The drive will use the standard deceleration rate when it expires. Setting this parameter to 0.0 disables the function.	Default: 0.0 s Min.: 0.0 Max.: 360.0
P9-99	Network Compatibility Selection	Determines the communication compatibility for the iQPump MEMOBUS network. 0: A-Ver: 30034 1: B-Ver: 30035/36 2: iQ Smart Network	Default: 2 Range: 0 to 2

■ Timing Diagrams - Speed Follower Deceleration Time Switchover (Disabled and Enabled)

P9-01 = 1 (Lowest Run-time)      P9-05 = 3 (Follow Lead Speed)  
 P9-08 = 0 (Output Frequency)      P9-12 = 0 (Output Frequency)  
 P9-32 = 60.0 sec                      P9-33 = 0.0 sec

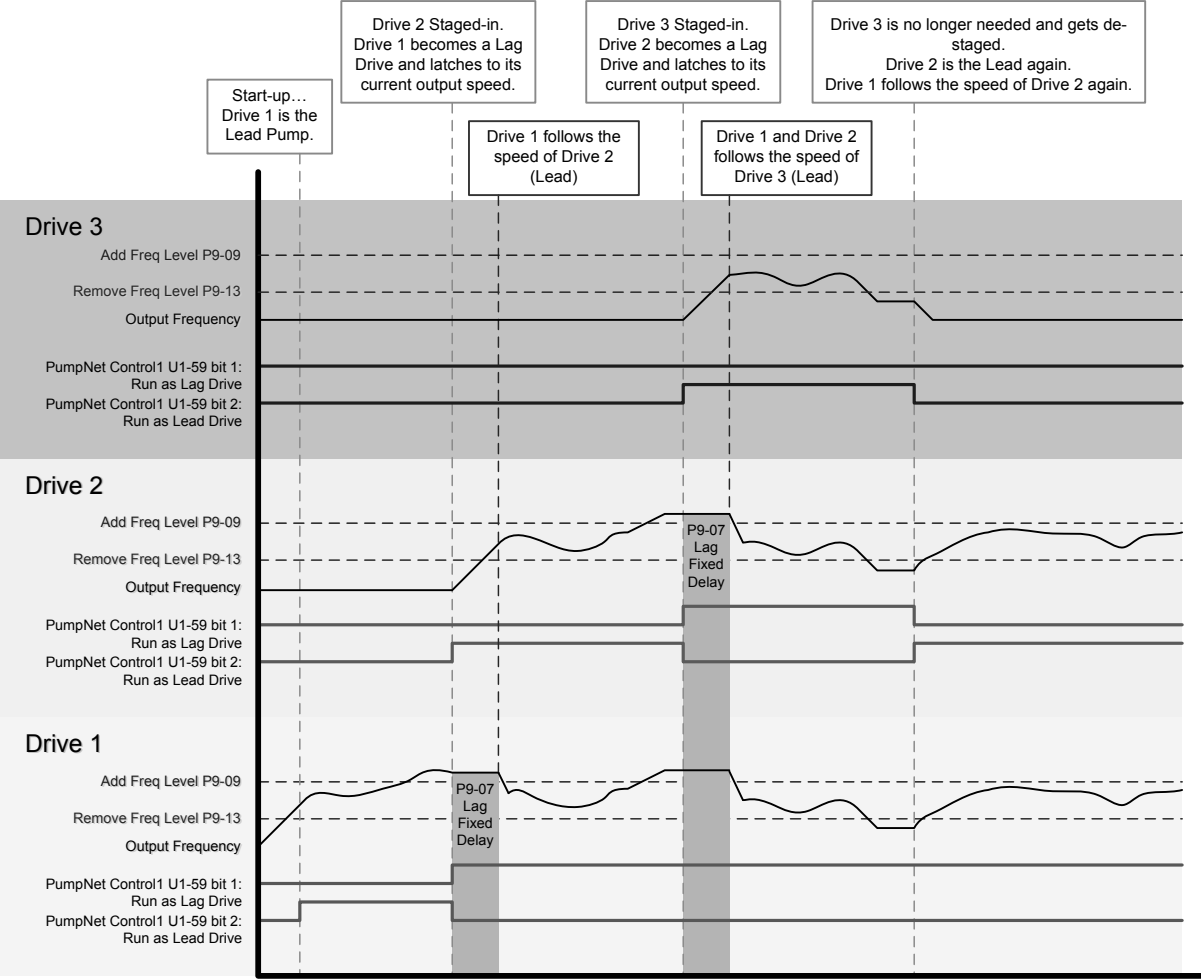

Figure 4.23 Lag Follower Deceleration Time Switching (Disabled)

## 4.6 iQpump Presets and Functions

P9-01 = 1 (Lowest Run-time)  
 P9-08 = 0 (Output Frequency)  
 P9-32 = 60.0 sec

P9-05 = 3 (Follow Lead Speed)  
 P9-12 = 0 (Output Frequency)  
 P9-33 = 10.0 sec

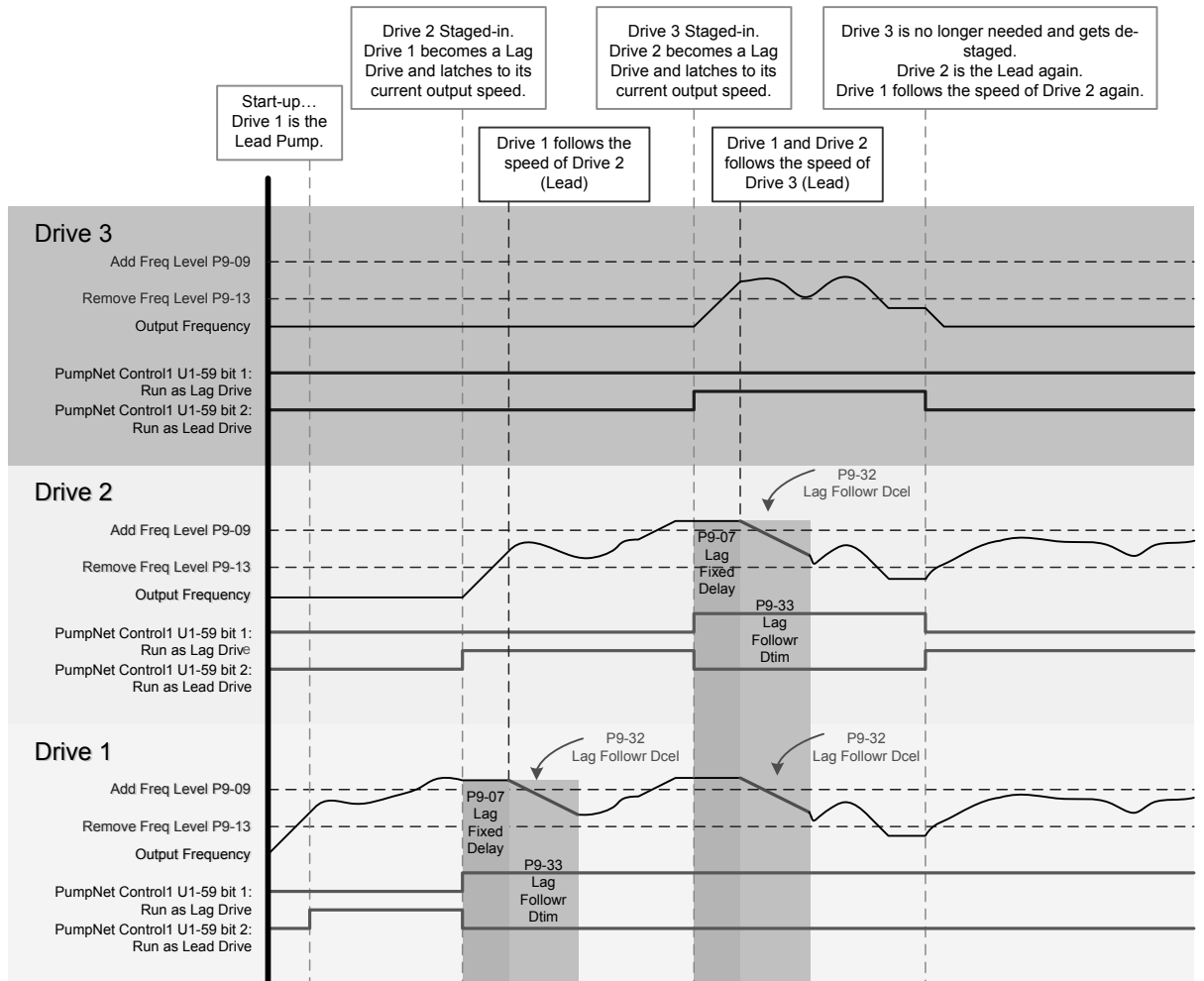

Figure 4.24 Lag Follower Deceleration Time Switching (Enabled)

## ◆ MEMOBUS Multiplexing System-wide Parameter Entry

This function allows parameter changes to be pushed through the MEMOBUS Multiplex network.

- Note:**
1. This function is available in drive software versions PRG: 8552 and later.
  2. Not available in drive models 4A0930 and 4A1200.

### ■ Network Parameter Push Operation

Parameter P9-98 enables and disables the network parameter push function.

When P9-98 is set to 0 (Disabled), changes to any parameter will only be written to the drive on which the parameter was changed.

When P9-98 is set to 1 (Enabled/Prompt), changes to system-wide parameters display the prompt shown in [Figure 4.25](#) asking whether to write the change on the selected drive or to all the drives on the network.

Changes to non-system-wide parameters will only be written to the drive on which the parameter was changed. [Refer to Non-System-Wide Parameters on page 192](#) for a list of non-system-wide parameters that cannot be pushed to other drives on the MEMOBUS Multiplex network.



Figure 4.25 Parameter Change Prompt

Selecting “Cancel” aborts the change.

Selecting “This Pump” causes the change to be written only on the drive on which the parameter was changed.

Selecting “System” attempts to write the change to the drive on which the parameter was changed and all other drives currently online (The number of nodes is based on P9-25).

The operator displays a WAIT message as shown in [Figure 4.26](#) for 5 s while the MEMOBUS Multiplex network writes to each node.

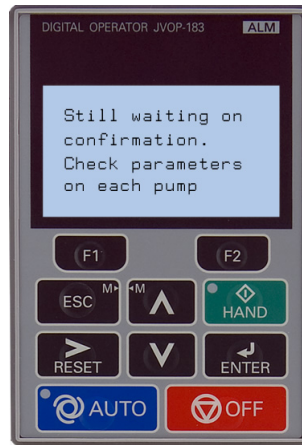

Figure 4.26 WAIT Message

The drive will display the confirmation screen shown in [Figure 4.28](#) after all drives have been accessed.

## 4.6 iQpump Presets and Functions

If the drive does not receive confirmation from all nodes after 5 s, the drive will display the message shown in [Figure 4.27](#).



**Figure 4.27 Still Waiting Message**

The Still Waiting message screen is dismissed after 15 s or when any key is pressed. The display then returns to the parameter selection screen.

The drive displays the confirmation screen shown in [Figure 4.28](#) if the confirmation comes back before the 15 s timer expires.

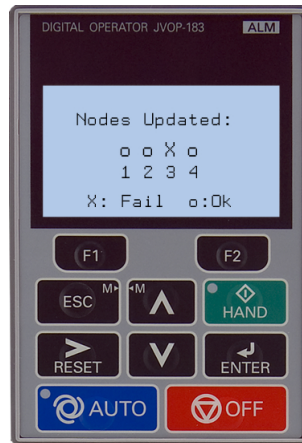

**Figure 4.28 Node Update Message**

Nodes that failed to update are indicated by an “X” while nodes that completed successfully are marked by an “o”.

The Node Update message is displayed for 1.5 s or until a key is pressed if all nodes successfully update. The message is displayed for 15 s or until a key is pressed if any node fails to update. The display then returns to the parameter selection screen.

### ■ Non-System-Wide Parameters

Parameters in [Table 4.16](#) cannot be pushed to other drives on the MEMOBUS Multiplex network.

**Table 4.16 Non-System-Wide Parameters**

No.	Name	No.	Name
A1-03	Initialize Mode	o4-05	Capacitor Maintenance Setting
A1-08	Custom Initialize Mode	o4-07	DC Bus Pre-charge Relay Maintenance Setting
H5-01	Drive Node Address	o4-09	IGBT Maintenance Setting
o2-04	Drive Model Selection	o4-11	Fault Data Initialization
o2-09	Factory	o4-12	kWh Monitor Initialization
o3-01	Copy Function Selection	o4-13	Number of Run Commands Counter Initialization
o4-01	Cumulative Operation Time Setting	o4-17	RTC Time Setting
o4-03	Cooling Fan Operation Time Setting	P1-01	Pump Mode



No.	Name
P9-20	Allow Network Run
P9-21	Run Priority

No.	Name
P9-27	Network Recovery Mode

### ■ Related Parameters

No.	Parameter Name	Setting Values
P9-98	Network Parameter Push Selection	Default: 0 Range: 0, 1

### ◆ De-Scale/De-Ragging

The De-scale/De-ragging function attempts to clean the pump impellers (dislodge scale and buildup) by rapidly starting and stopping the pump in both directions. The drive monitors the number of operating hours of the motor and after a set amount of operating time, the drive runs the De-scale/De-ragging function the next time the drive is started in either the HAND or AUTO mode.

The De-scale/De-ragging function runs the drive forward, then reverse for a specified number of times before normal operation will automatically resume.

The De-Scale/De-ragging function operates when all of the following conditions are met:

- P8-01 = 1: De-Scale is Enabled
- P1-01 ≠ 3: Not in MEMOBUS Multiplex
- P7-01 = 0: Anti-Jam Disabled

### ■ De-Scale/De-Ragging Operation

While the pump is running in the Hand or Auto mode, the De-scale/De-ragging run timer is activated. The timer data is stored in EEPROM at power-down. If the amount of time accumulated in the timer is less than the De-Scale Pump Run Time parameter (P8-08), the drive starts normally. When the timer is equal to or greater than the P8-08 value, the drive will automatically perform the de-scale function the next time the drive is at a stop and is commanded to accelerate in HAND or AUTO mode.

The “De-Scale/De-rag Active” alarm will flash on the keypad during the De-scale/De-ragging function. The drive will first accelerate using the De-scale Acceleration Time (P8-06) up to the De-scale Run Frequency Reference (P8-03), for the De-scale Forward Run Time (P8-04) time. It will then decelerate using the De-scale Deceleration Time (P8-07) and accelerate using P8-06 in the reverse direction. It will stay running at the P8-03 speed for the time set in the De-Scale Reverse Run Time (P8-05). After the timer expires, drive will decelerate to zero using P8-07. Once it reaches zero speed, it will immediately repeat the cycle for as many times as specified by the De-scale cycle count (P8-02) parameter. If the De-scale/De-ragging function is interrupted by a fault or by removing the run command, all timers associated with the De-scale/De-ragging function will be reset.

During de-scaling / de-ragging operation, the following features are disabled:

- PI Control (pressure control)
- Thrust Bearing Acceleration
- Minimum Speed
- Low Feedback / High Feedback Detection
- Not Maintaining Setpoint Detection
- Loss of Prime
- Low Flow / High Flow Detection
- Level Control / Suction Control / Vacuum Control
- Sleep Detection
- Sleep Boost

### ■ Forced De-Scale/De-Ragging Operation

When parameter P8-01 = 2 (Force De-scale), the drive will perform a De-scale/De-ragging operation every time it starts. This mode is intended to be used during the setup of the De-scale/De-ragging function only.

### ■ Related Parameters, Multi-Function Digital Output Settings, and Alarms

No.	Parameter Name	Setting Values
P8-01	De-scale Operation Selection	Default: 0 Range: 0 to 2
P8-02	De-scale Cycle Count	Default: 1 Range: 1 to 100
P8-03	De-scale Frequency Reference	Default: 25.00 Hz Range: 0.0 to 400.0
P8-04	De-scale Forward Run Time	Default: 10 s Range: 1 to 6000
P8-05	De-scale Reverse Run Time	Default: 10 s Range: 1 to 6000

No.	Parameter Name	Setting Values
P8-06	De-scale Acceleration Time	Default: 2.0 s Range: 0.0 to 600.0
P8-07	De-scale Deceleration Time	Default: 2.0 s Range: 0.0 to 600.0
P8-08	De-scale Pump Run Time	Default: 168.0 H Range: 0.1 to 2000.0

H2 Multi-Function Digital Output Settings		
H2-□□	Function	Description
A6	De-scale Active	Closed: De-scale is running

### ◆ 2-Motor Contactor Alternation

Parameter P4-14 enables and disables the 2-motor contactor alternation function.

This function allows one drive to power two motors in an “OR” configuration to evenly distribute the amount of wear on each motor/pump.

- Note:**
1. This function is available in drive software versions PRG: 8552 and later.
  2. Not available in drive models 4A0930 and 4A1200.

#### ■ 2-Motor Alternation Disabled (P4-14 = 0)

Setting P4-14 to 0 disables 2-motor alternation, clears all timers associated with the 2-motor alternation function, and de-energizes digital output H2-0□ = 43.

#### ■ 2-Motor Alternation Enabled (P4-14 = 1)

Setting P4-14 to 1 enables the 2-motor alternation function. The drive de-energizes digital output H2-0□ = 43 to force the relay/contactor logic to connect the first motor to the drive output terminals.

The alternation timer runs when the drive applies power to the motor (i.e., running, non-zero speed, not baseblocked). The drive switches to the second motor when the timer reaches the time entered in P4-16, Alternation Time, depending on the setting of P4-15, Two Motor Alternation Operation Selection.

If P4-15 is set to 0 (Wait For Stop), the drive will continue to operate on Motor 1 until the drive would normally go to zero speed (zero reference, sleep mode, remove run command, fault). When the drive stops, digital output H2-0□ = 43 energizes so the drive will run motor 2 when it restarts.

If P4-15 is set to 1 (Immediate) and the drive is operating in Auto Mode when the alternation timer reaches the time set in P4-16, the drive will immediately stop using the selected stopping method (b1-03). When the drive stops, digital output H2-0□ = 43 energizes and the drive will restart and ramp back to speed after the minimum baseblock time.

If the drive is operating in Hand Mode when the alternation timer reaches the time set in P4-16, the will continue to operate on Motor 1 until the drive would normally go to zero speed (zero reference, sleep mode, remove run command, fault). When the drive stops, digital output H2-0□ = 43 energizes so the drive will run motor 2 when it restarts.

The alternation timer restarts after the digital output switches to drive Motor 2. The drive switches back to Motor 1 depending on the setting of P4-15 after sufficient time passes with the drive running that the alternation timer reaches the P4-16 level.

The alternation timer and motor selection are stored to EEPROM when power is removed. Changing parameter P4-14 clears the internal alternation timer and the alternation time stored in EEPROM..

P4-14 special considerations:

- Motor 1 is used first when P4-14 changes from 0 to 1
- Motor 2 is used first when P4-14 changes from 2 to 1
- Motor 1 is used first when P4-14 changes from 3 to 1

#### ■ Motor 1 Only (P4-14 = 2)

Setting P4-14 to 2 disables the 2-motor alternation function, clears all timers associated with the 2-motor alternation function, and de-energizes digital output H2-0□ = 43.

#### ■ Motor 2 Only (P4-14 = 3)

Setting P4-14 to 3 disables the 2-motor alternation function is disabled, clears all timers associated with the 2-motor alternation function, and energizes digital output H2-0□ = 43.

#### ■ Interaction with Sequence Timer (S2-□□)

Setting the sequence Selection (S2-04, S2-09, S2-14, S2-19) to 3, No Alternation, prevents 2-motor alternation during the time set in the corresponding Sequence Timer. Alternation resumes normally when the timer deactivates.

- Note:** The Alternation Time set in P4-16 will run during the No Alternation time window. The timer will request for alternation after the No Alternation time window is over if the timer expires.

## ■ Related Parameters, Monitors, and Multi-Function Digital Output Settings

No.	Parameter Name	Setting Values
P4-14	Two Motor Alternation Selection	Default: 0 Range: 0 to 3
P4-15	Two Motor Alternation Operation Selection	Default: 0 Range: 0, 1
P4-16	Two Motor Alternation Time	Default: 24.0 H Range: 0.1 to 100.0 H
U1-82	Two Motor Time to Alternate	Full scale: N/A

H2 Multi-Function Digital Output Settings		
H2-□□	Function	Description
43	2 Motor Alternate	Open: Motor 1 in use (or 2-motor alternation is disabled) Closed: Motor 2 in use

### ◆ Flow Rate Limiter

The flow rate limiter function reduces speed when the flow rate reaches a high or low limit to reduce system pressure.

- Note:**
1. This function is available in drive software versions PRG: 8552 and later.
  2. Not available in drive models 4A0930 and 4A1200.

The drive reduces the output speed to limit the flow rate. Parameter P6-27 determines whether the Flow Rate Limit Level acts as a High Limit (P6-26 = 1) or a Low Limit (P6-26 = 2).

When P6-26 is set to 1 (Enabled), the output speed is reduced when the Flow Rate rapidly increases or rises above the level set in P6-27.

When P6-27 is set to 2 (Enabled – Low Limit), the output speed is reduced through a PI controller when the Flow Rate rapidly decreases or falls below the level set in P6-27. The output speed is lower-limited to the greater value between the Minimum Pump Speed (P1-06) or Thrust (P4-12), plus the Minimum Output Frequency (E1-09).

Parameters P6-28 (Proportional Gain) and P6-29 (Integral Time) adjust the responsiveness of the PI controller.

Flow Limit Start Delay (P6-30) sets the length of time that the drive will wait before activating the Flow Rate Limiter at Start.

- Note:** When the Flow Limit Start Delay (P6-30) timer expires, the output speed may rapidly decrease depending on the Flow Rate level compared to the Flow Limit (P6-27). Be sure to set P6-30 long enough to allow the system to stabilize the Flow Rate.

### ■ Total Accumulated Volume and Delta Accumulated Volume Monitors

Monitors U1-84 to U1-87 represent the Total Accumulated Volume as shown below:

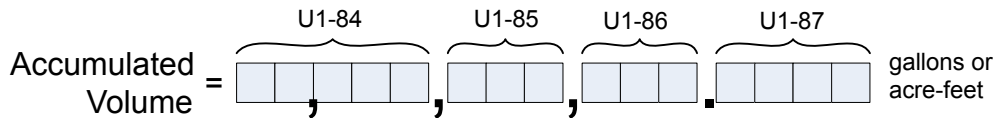

Monitor U1-88 provides the same information in a single display. The decimals are dropped when P6-16 is set to 1 to display in gallons. When the value being displayed is more than 99999 gal or units are in A-F (P6-16 = 2), the display will initially show “U1-88 = - - gal“ or “U1-88 = - - A-F” and immediately switch over to the full value with the monitor number removed.

The unit and commas may be removed depending on the size of the value. Note that the unit is always displayed in the Monitor Title Text (Total Vol (gal) or Total Vol (A-F)).



Monitor U1-89 shows the volume accumulated with the values stored in parameters P6-36 to P6-39 (Delta Volume) as the starting point. The display operates the same as U1-88, except that it can be signed and switched to full value display when above 9999 gal or below -9999 gal.

- Note:** When the units are in Acre-feet, the number of decimal places decreases by 1 when the value is above 9,999,999,999.9999 A-F or below -9,999,999,999.9999 A-F.

The value for U1-89 is equal to the Total Accumulated Volume (U1-88/U1-84 to U1-87) – Starting Delta Volume (P6-36 to P6-39).

Starting Delta Volume parameters P6-36 to P6-39 can be populated manually by individually setting each parameter. Setting P6-35 to 1 (Set) will write the current Total Accumulated Volume (U1-88/U1-84~U1-87) to the parameters, while setting P6-35 to 2 (Reset) will write 0 to these parameters.

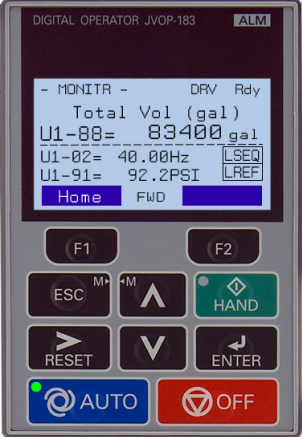
Sample Screens

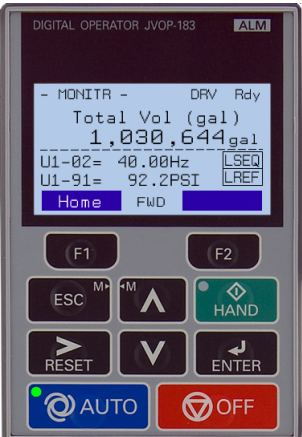
LCD Display	Description
 <p>The LCD display shows the following information: DIGITAL OPERATOR JVOP-183, ALM, - MONITR -, DRV Rdy, Total Vol (gal) 83400 gal, U1-02= 40.00Hz, U1-91= 92.2PSI, Home, FWD, and buttons for F1, F2, ESC, HAND, RESET, ENTER, AUTO, and OFF.</p>	<p>Displaying in Gallons and value is less than 100,000. Displays normally.</p>
 <p>The LCD display shows the following information: DIGITAL OPERATOR JVOP-183, ALM, - MONITR -, DRV Rdy, Total Vol (gal) -- gal, U1-02= 40.00Hz, U1-91= 92.2PSI, Home, FWD, and buttons for F1, F2, ESC, HAND, RESET, ENTER, AUTO, and OFF.</p>	<p>Displaying in gallons and value is greater than 99,999. Displays double dashes for 1.5 s, then displays the full value.</p>
 <p>The LCD display shows the following information: DIGITAL OPERATOR JVOP-183, ALM, - MONITR -, DRV Rdy, Total Vol (gal) 1,030,644 gal, U1-02= 40.00Hz, U1-91= 92.2PSI, Home, FWD, and buttons for F1, F2, ESC, HAND, RESET, ENTER, AUTO, and OFF.</p>	<p>Full value display with units and commas.</p>

## 4.6 iQpump Presets and Functions

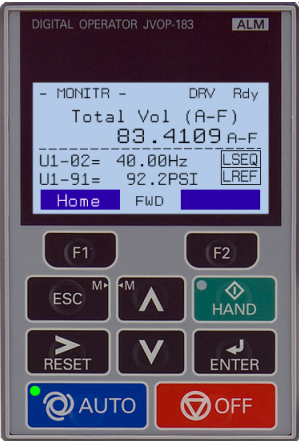
LCD Display	Description
 <p>The LCD display shows the following information: DIGITAL OPERATOR JVOP-183, ALM, - MONITR -, DRV Rdy, Total Vol (gal) 17,221,030.644, U1-02= 40.00Hz, U1-91= 92.2PSI, LSEQ, LREF, Home, FWD, F1, F2, ESC, HAND, RESET, ENTER, AUTO, OFF.</p>	<p>Full value display with commas, but no unit in-line.</p>
 <p>The LCD display shows the following information: DIGITAL OPERATOR JVOP-183, ALM, - MONITR -, DRV Rdy, Total Vol (A-F) 83.4109 A-F, U1-02= 40.00Hz, U1-91= 92.2PSI, LSEQ, LREF, Home, FWD, F1, F2, ESC, HAND, RESET, ENTER, AUTO, OFF.</p>	<p>Full value display for Acre-Feet units.</p>
 <p>The LCD display shows the following information: DIGITAL OPERATOR JVOP-183, ALM, - MONITR -, DRV Rdy, Total Vol (A-F) 17221939690.8552, U1-02= 40.00Hz, U1-91= 92.2PSI, LSEQ, LREF, Home, FWD, F1, F2, ESC, HAND, RESET, ENTER, AUTO, OFF.</p>	<p>Full value display with no units and no commas.</p>

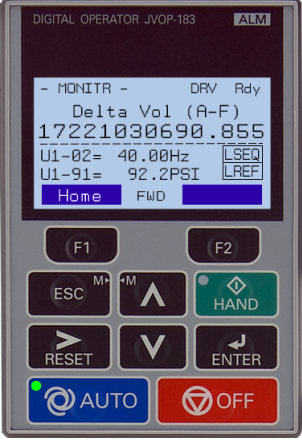

LCD Display	Description
	<p>Delta Volume: Full display with units, commas, and sign.</p>
	<p>Delta Volume: Full display with no units, no commas, and resolution decreased.</p>

**■ Low Flow Detection Delay at Start Cancel**

The Low Flow Rate detection is enabled when all of the following are true:

- There is a valid flow meter input: pulse input, analog input, or MEMOBUS network.
- The Low Flow Level parameter P6-06 > 0.
- The drive is running in Hand or Auto and the output frequency is greater than 0 for longer than the time set in P6-08.

**■ Related Parameters, Monitors, and Multi-Function Digital Output Settings**

No.	Parameter Name	Setting Values
P6-01	Flow Meter Scaling	Default: 0.0 GPM Range: 0.0 to 6000.0 GPM
P6-02	Turbine Input Scaling (Coarse)	Default: 0 ppG Range: 0 to 6000 ppG
P6-03	Turbine Input Scaling (Fine)	Default: 0.0000 ppG Range: 0.0000 to 0.9999 ppG
P6-06	Low Flow Level	Default: 0.0 Range: 0.0 to 6000.0
P6-07	Low Flow Detection Delay Time When Already Running	Default: 10 s Range: 0 to 6000 s
P6-08	Low Flow Detection Wait Time At Start	Default: 0.0 min Range: 0.0 to 3600.0 min
P6-09	Low Flow Select	Default: 1 Range: 0 to 3
P6-17	High Flow Level	Default: 0.0 Range: 0.0 to 6000.0

## 4.6 iQpump Presets and Functions

No.	Parameter Name	Setting Values
P6-21	Low Flow Detection Delay @ Start Cancel Time	Default: 5 s Range: 0 to 6000 s
P6-22	Flow Meter Decimal Place Position	Default: 1 Range: 0 to 2
P6-26	Flow Limit Selection	Default: 0 Range: 0 to 2
P6-27	Flow Limit Level	Default: 0.0 Range: 0.0 to 6000.0
P6-28	Flow Limit Regulator Gain	Default: 0.00 Range: 0.00 to 25.00
P6-29	Flow Limit Regulator Integral Time	Default: 1.00 s Range: 0.00 to 25.00 s
P6-30	Flow Limit Regulator Delay @ Start	Default: 10 s Range: 0 to 6000 s
P6-35	Accumulator Delta Save Selection	Default: 0 Range: 0 to 2
P6-36	Delta Starting Accumulation Level - Millions	Default: 0 Range: 0 to 65535
P6-37	Delta Starting Accumulation Level - Thousands	Default: 0 Range: 0 to 999
P6-38	Delta Starting Accumulation Level - Ones	Default: 0 Range: 0 to 999
P6-39	Delta Starting Accumulation Level - Decimal	Default: 0.0000 Range: 0.0000 to 0.9999
P9-41	Add Flow Level	Default: 0.0 GPM Range: 0.0 to 6000.0 GPM
P9-42	Remove Flow Level	Default: 0.0 GPM Range: 0.0 to 6000.0 GPM
U1-83	Flow Rate	Full scale: P6-01 Setting
U1-88	Total Volume Accumulated	Full scale: N/A
U1-89	Delta Volume Accumulated	Full scale: N/A

### H2 Multi-Function Digital Output Settings

H2-□□	Function	Description
A7	Flow Rate Limit	Closed: The Flow Rate is actively affecting the output speed.

## ◆ Multi-function Digital Input On/Off Time Delay

This function provides an On/Off Delay to all multi-function digital inputs.

- Note:**
1. This function is available in drive software versions PRG: 8552 and later.
  2. Not available in drive models 4A0930 and 4A1200.

When the terminal closes, the function programmed to that terminal activates after the corresponding on-delay timer elapses. Opening the terminal will reset the on-delay timer. When the terminal opens and the function is active, the function continues to run until the off-delay timer elapses. Closing the terminal again will reset the off-delay timer.

The on-delay and off-delay timers also affect monitor U1-10 (Input Terminal Status). The corresponding bits are set when the function is active after the on-delay elapses. The bits are reset when the function is deactivated after the off-delay elapses. The on-delay timer does not apply when the inputs are already closed at power-up.

### ■ Related Parameters

No.	Parameter Name	Setting Values
H1-37, H1-38	Terminals S7 and S8 On-Delay Time	Default: 0.00 s Range: 0.00 to 300.00 s
H1-41 to H1-48	Terminals S1 to S8 Off-Delay Time	Default: 0.00 s Range: 0.00 to 300.00 s

### ◆ PI Auxiliary Control

PI Auxiliary Control allows the drive to control pressure when the PI Auxiliary Level is adequate. When the PI Auxiliary Control Level drops to the PI Auxiliary Control Setpoint set in Q6-03, the drive will regulate based on the PI Aux Level and the pressure will drop.

The drive also goes to sleep, wakes up, and trips an alarm and/or fault based on the PI Auxiliary Control level.

- Note:**
1. This function is available in drive software versions PRG: 8552 and later.
  2. Not available in drive models 4A0930 and 4A1200.

### ■ Enable PI Aux Level Control Features

Set parameter Q6-01 to 1 to enable PI Aux Level Control and PI Aux Low Level Detection.

The drive performs PI Aux Level Control when Q6-20 is set to 1 and the drive is in PID mode (PID enabled via b5-01, not jogging, and not disabled by other functions).

Sleep via Minimum and Maximum Levels (Q6-04 and Q6-24) apply to both Q6-20 modes.

### ■ Scaling and Resolution

Q6-21 sets the unit and Q6-22 sets the decimal place for the PI Aux Level parameters and monitors.

### ■ Data Entry Modes for Wake-up Level, Low Level, and High Level Detection

Parameter/Condition	Delta Entry	Absolute Entry	Range Display (Toggles Automatically)
Q6-06 Wake-up Level PI Direct-acting (Q6-23 = 0)	-0.0 to -999.9	0.0 to 999.9	(0.0 to 999.9) <-> "--Sub frm SetPt"
Q6-06 Wake-up Level PI Inverse-acting (Q6-23 = 1)	+0.0 to +999.9	0.0 to 999.9	(0.0~999.9) <-> "+Add to SetPt"
Q6-09 Low Feedback Level	-0.0 to -999.9	0.0 to 999.9	(0.0 to 999.9) <-> "--Sub frm SetPt"
Q6-12 High Feedback Level	+0.0 to +999.9	0.0 to 999.9	(0.0~999.9) <-> "+Add to SetPt"

### ■ Sensing PI Aux Feedback Level

Set a multi-function analog input H3-□□ to 27 to act as the PI Auxiliary Feedback Level and set parameter Q6-02 to the full-scale pressure of the transducer, with units and decimal place set by Q6-21 and Q6-22. This level is displayed on the U1-96 monitor.

Wire break is detected for the PI Aux FB Level analog input when all of the following are true:

- Q6-19 ≠ 0 to enable PI Aux Feedback Wire-Break Detection.
- Q6-01 = 1 enabling PI Auxiliary Control.
- The multi-function analog input programmed for PI Aux FB Level (H3-□□ = 27) is set for 4 to 20 mA operation (H3-□□ = 2)
- The signal on the analog input falls below 3 mA or rises above 21 mA for longer than 1 second.

The drive responds based on the Q6-19 setting:

- Setting 0: Wire-break detection is disabled.
- Setting 1: The "AUXFB – PI Aux Lvl Loss" alarm will display.
- Setting 2: The drive will trigger an "AUXFB – PI Aux Lvl Loss" fault if the drive is in Auto, Hand, or Sleep.

If there is not a Run command present, the drive will display an "AUXFB – PI Aux Lvl Loss" alarm.

### ■ Direct-Acting PI Aux Level Control (Q6-23 = 0)

The drive will respond in one of two ways to a change in the PI Aux Feedback when Q6-23 is set to 0:

- The drive will attempt to regulate to the Q6-03 level when Q6-03 setpoint < Q6-24 maximum level.

The drive slows down as the feedback level approaches the Q6-03 setting and pressure and flow decrease. The drive then regulates output speed to maintain the PI Aux Level. Adjust the drive regulating level responsiveness using parameters Q6-16 and Q6-17.

The drive will go to sleep if level rises above the Q6-24 maximum value for longer than the Q6-05 sleep delay time. Normal operation resumes when the feedback level falls below the Q6-06 wake-up level for longer than the Q6-07 wake-up time.

- Note:** Be sure to set Q6-08, PI Aux Control Minimum Speed, to a value high enough to ensure flow.

- The drive will attempt to maintain the pressure setpoint before immediately going to sleep based on PI Aux Feedback when Q6-03 setpoint > Q6-24 maximum level.

The drive goes to sleep when the Feedback Level rises above the Q6-24 maximum level for longer than the Q6-05 sleep delay time. Normal operation resumes when the PI Aux Feedback falls below the Q6-06 level for longer than the Q6-07 time.

### ■ Inverse-Acting PI Aux Level Control (Q6-23 = 1)

The drive will respond in one of two ways to a change in the PI Aux Feedback when Q6-23 is set to 1:

- The drive will attempt to regulate to the Q6-03 level when Q6-03 setpoint > Q6-24 maximum level.

The drive slows down as the feedback level approaches the Q6-03 setting and pressure and flow decrease. The drive then regulates output speed to maintain the PI Aux Level. Adjust the drive regulating level responsiveness using parameters Q6-16 and Q6-17.

The drive will go to sleep if level falls below the Q6-24 maximum value for longer than the Q6-05 sleep delay time. Normal operation resumes when the feedback level rises above the Q6-06 wake-up level for longer than the Q6-07 wake-up time.

**Note:** Be sure to set Q6-08, PI Aux Control Minimum Speed, to a value high enough to ensure flow.

- The drive will attempt to maintain the pressure setpoint before immediately going to sleep based on PI Aux Feedback when Q6-03 setpoint < Q6-24 maximum level.

The drive goes to sleep when the Feedback Level falls below the Q6-24 maximum level for longer than the Q6-05 sleep delay time. Normal operation resumes when the PI Aux Feedback rises above the Q6-06 level for longer than the Q6-07 time.

### ■ Sleep & Wake-Up Methods

The drive goes to sleep in one of three separate methods:

- The drive goes to sleep without performing a sleep boost when the PI Aux Feedback falls below the Minimum Level (Q6-04) for longer than the PI Auxiliary Control Sleep Delay Time (Q6-05),

The drive wakes up when the PI Aux Feedback level rises above the Setpoint (Q6-03) for longer than the time set in Q6-07 and the standard (pressure) sleep function set in P1-04 and P1-05 calls for a wake-up.

- The drive goes to sleep without performing a sleep boost when the PI Aux feedback rises above the Maximum Level (Q6-24) for longer than the PI Auxiliary Control Sleep Delay Time (Q6-05).

The drive wakes up when the PI Aux Feedback level falls below the Setpoint (Q6-03) for longer than the time set in Q6-07 and the standard (pressure) sleep function set in P1-04 and P1-05 calls for a wake-up.

- The drive will also go to sleep based upon the standard sleep settings set in parameters P2-01 to P2-04 and perform a sleep boost.

When Q6-23 is set to 1 (Inverse-acting), the drive wakes up when the PI Aux Feedback rises above the Setpoint (Q6-03) for longer than the Q6-07 time AND the standard sleep function set in P1-04 and P1-05 calls for a wake-up.

When Q6-23 is set to 0 (Direct-acting), the drive wakes up when the PI Aux Feedback falls below the Setpoint (Q6-03) for longer than the Q6-07 time AND the standard sleep function set in P1-04 and P1-05 calls for a wake-up.

### ■ PI Aux Low Level Detection

Set Q6-01 to 1 and Q6-09 > 0 to enable PI Aux Low Level Detection.

#### Low Level Behavior – No Display:

The Low PI Aux Level digital output (H2-0□ = 9E) closes when Q6-11 = 0 (No Display) and the PI Aux Feedback falls below the level set in Q6-09. The digital output opens when the feedback rises above the level set in Q6-09.

#### Low Level Behavior – Alarm Only:

The “LOAUX – Low PI Aux Lvl” alarm displays and the digital output closes when Q6-11 = 1 (Alarm Only) and the PI Aux Feedback falls below the level set in Q6-09. The alarm clears and the digital output opens when the feedback rises above the level set in Q6-09.

#### Low Level Behavior – Fault:

The digital output closes and the alarm displays when Q6-11 = 2 or 3 (Fault), the output frequency > 0, and the PI Aux Feedback falls below the level set in Q6-09. The drive faults out with a “LOAUX – Low PI Aux Lvl” fault if the feedback remains below the Q6-09 level for the time set in Q6-10.

## 4.6 iQpump Presets and Functions

### Low Level Behavior – Auto-Restart:

The drive attempts to auto-restart after the PI Aux Level Control Auto-Restart Time (Q6-15) expires if the drive faults out on a “LOAUX – Low PI Aux Lvl” Fault, parameter Q6-11 = 3, and L5-01 > 0 to enable auto-restarts. The auto-restart counter increments and the drive remains faulted until the feedback rises above the level set in Q6-09.

### ■ PI Aux High Level Detection

Set Q6-01 to 1 and Q6-12 > 0 to enable PI Aux High Level Detection.

### High Level Behavior – No Display:

The High PI Aux Level digital output (H2-0□ = 9F) closes when Q6-14 = 0 (No Display) and the PI Aux Feedback rises above the level set in Q6-12. The digital output opens when the feedback falls below the level set in Q6-12.

### High Level Behavior – Alarm Only:

The “HIAUX – Hi PI Aux Lvl” alarm displays and the digital output closes when Q6-14 = 1 (Alarm Only) and the PI Aux Feedback rises above the level set in Q6-12. The alarm clears and the digital output opens when the feedback falls below the level set in Q6-12.

### High Level Behavior – Fault:

The digital output closes and the alarm displays when Q6-14 = 2 or 3 (Fault), the output frequency > 0, and the PI Aux Feedback goes rises above the level set in Q6-12. The drive faults out with a “HIAUX – Hi PI Aux Lvl” fault when the feedback remains above the Q6-12 level for the Q6-13,

### High Level Behavior – Auto-Restart:

The drive attempts to auto-restart after the PI Aux Level Control Auto-Restart Time (Q6-15) expires if the drive faults out on a “HIAUX – Hi PI Aux Lvl” Fault, parameter Q6-14 = “3, and L5-01 > 0 to enable auto-restarts. The auto-restart counter increments and the drive remains faulted until the feedback falls below the level set in Q6-12.

### ■ Related Parameters

No.	Parameter Name	Setting Values
P9-50	Water Level/Suction Pressure/PI Aux Source	Default: 0 Range: 0 to 3
P9-51	Low Water Level/ Suction Pressure Turn-Off Method	Default: 0 Range: 0, 1
Q6-01	PI Auxiliary Control Selection	Default: 0 Range: 0, 1
Q6-02	PI Auxiliary Control Feedback Scale	Default: 145.0 Range: 1.0 to 600.0
Q6-03	PI Auxiliary Control Setpoint	Default: 20.0 Range: 0.0 to 6000.0
Q6-04	PI Auxiliary Control Minimum Level	Default: 10.0 Range: 0.0 to 6000.0
Q6-05	PI Auxiliary Control Sleep Delay Time	Default: 5 s Range: 0 to 3600 s
Q6-06	PI Auxiliary Control Wake-up Level	Default: 30.0 Range: 0.00 to 999.9
Q6-07	PI Auxiliary Control Wake-up Time	Default: 1 s Range: 0 to 3600 s
Q6-08	PI Auxiliary Control Minimum Speed	Default: 0.00 Hz Range: 0.00 to 400.00 Hz
Q6-09	PI Auxiliary Control Low Level Detection	Default: 0.0 Range: 0.0 to 999.9
Q6-10	PI Auxiliary Control Low Level Detection Time	Default: 0.1 min Range: 0.0 to 300.0 min
Q6-11	PI Auxiliary Control Low Level Detection Selection	Default: 1 Range: 0 to 3
Q6-12	PI Auxiliary Control High Level Detection	Default: 0.0 Range: 0.0 to 999.9

No.	Parameter Name	Setting Values
Q6-13	PI Auxiliary Control High Level Detection Time	Default: 0.1 min Range: 0.0 to 300.0 min
Q6-14	PI Auxiliary Control High Level Detection Selection	Default: 1 Range: 0 to 3
Q6-15	PI Auxiliary Control Level Detection Restart Time	Default: 5.0 min Range: 0.1 to 6000.0 min
Q6-16	PI Auxiliary Control P Gain	Default: 2.00 Range: 0.00 to 25.00
Q6-17	PI Auxiliary Control I Time	Default: 5.0 s Range: 0.0 to 360.0 s
Q6-18	PI Auxiliary Control Detection Time Unit	Default: 0 Range: 0, 1
Q6-19	PI Auxiliary Control Feedback Wirebreak	Default: 2 Range: 0 to 2
Q6-20	PI Auxiliary Control Main PI Control	Default: 1 Range: 0, 1
Q6-21	PI Auxiliary Control Level Unit Selection	Default: 1 Range: 0 to 11; 26
Q6-22	PI Auxiliary Control Level Decimal Place Position	Default: 1 Range: 0 to 3
Q6-23	PI Auxiliary Control Output Level Selection	Default: 1 Range: 0, 1
Q6-24	PI Auxiliary Control Maximum Level	Default: 0.0 Range: 0.0 to 6000.0
U1-96	PI Auxiliary Control Feedback Level	–

**H1 Multi-Function Digital Input Settings**

H1-□□	Function	Description
82	PI Switch to Aux	Closed: PI Auxiliary Control (Q6-□□) becomes the primary PI loop, disabling the System PI controller (b5-□□). Overrides Q6-20 if set to 0 (Disable Effect on Speed Control).

**H2 Multi-Function Digital Output Settings**

H2-□□	Function	Description
9E	Low PI Aux Lvl	Energizes when the PI Aux Feedback Level falls below the Low PI Aux Level (Q6-09), or if there is a LOAUX – Low PI Aux Level Fault.
9F	Hi PI Aux Lvl	Energizes when the PI Aux Feedback Level rises above the High PI Aux Level (Q6-12), or if there is a HIAUX – Hi PI Aux Lvl Fault.
A0	WL/SP/PIAux Ctrl	Closed when the Water Level, Suction Pressure, or PI Auxiliary Controller is affecting the output speed.

**H3 Multi-Function Analog Input Settings (H3-02/H3-06/H3-10)**

H3-02/06/10	Function	Description
27	PI Auxiliary Feedback Level	0 V or 4 mA = 0 (unit based on Q6-22) 10 V or 20 mA = Q6-02 (unit based on Q6-22)

### ◆ Hybrid Sequence Control

#### ■ CALL Alarm at Power Up

Parameter H5-13 enables and disables the “CALL” alarm that occurs at power-up when the Sequence or Reference Source is set for Serial or Option.

**Run Source: AUTO Key + Terminals (b1-02/b1-16 = 6), AUTO Key + Serial (b1-02/b1-16 = 7), or AUTO Key + Option (b1-02/b1-16 = 8)**

When b1-02 or b1-16 are set to 6, the AUTO key puts the drive in Auto Mode and the terminal programmed for Run (H1-□□ = 40, 41, or 42) acts as the External Run command.

When b1-02 or b1-16 are set to 7, the AUTO key puts the drive into Auto Mode and the Serial Run command (register 0001) acts as the External Run command.

When b1-02 or b1-16 are set to 8, the AUTO key puts the drive in Auto mode and the Option Card Run command acts as the External Run command.

All of these settings establish the Run command when the AUTO key and External Run command are active.

Pressing the AUTO key when the External Run command is not present will latch the key and cause the AUTO LED to blink. Pressing OFF will unlatch the AUTO key.

Issuing the External Run command before latching the AUTO key will cause the AUTO LED to blink and indicate an incomplete Run command. Removing the External RUN command will stop the AUTO LED from blinking. The drive will run in AUTO Mode when the AUTO key is latched and the External RUN command is present.

The following table shows possible combinations and their effect on the drive:

AUTO Key Latched	External Run	AUTO LED	Drive Runs?	Description
No	No	OFF	No	Drive stopped
Yes	No	Blinking	No	AUTO key latched, waiting for Run
No	Yes	Blinking	No	Run command given, waiting for AUTO key
Yes	Yes	ON	Yes	AUTO Mode Run

**Note:** Set P4-10 to 1 (Auto Mode Operation Power-Down Storage enabled) to save the AUTO key latch through a power-cycle.

#### ■ Related Parameters

No.	Parameter Name	Setting Values
b1-02	Run Command Selection 1	Default: 0 Range: 0 to 8
b1-16	Run Command Selection 2	Default: 0 Range: 0 to 8
H5-13	Power-up CALL Alarm	Default: 0 Range: 0, 1



## ◆ Differential Level Detection

Differential Level Detection detects the pressure difference between the PID Feedback (H3-□□ = B) and a secondary pressure feedback device (H3-□□ = 28).

### ■ Enable Differential Level Detection

Ensure that all of the following conditions are met to enable Differential PI Feedback Detection:

- P4-18 > 0
- Program the Differential Feedback analog input (H3-□□ = 28)
- The drive is not in Anti-Jam or De-scale operation
- For Direct-Acting PID, the drive is running in AUTO mode (including sleep boost and feedback drop detection)

For Inverse-Acting PID, the drive has a Run command present.

With detection enabled, the drive detects the pressure difference between the PID Feedback and the Differential Feedback (H3-□□ = 28).

The digital output programmed for “Differential Det” (H2-□□ = A1) closes when the difference exceeds the level set in P4-18 for the time set in P4-19.

The drive responds depending on the setting for P4-20 (Differential Detection Selection)

The drive triggers a “Differential FB Detected” alarm and closes the digital output when P4-20 is set to 1 (Alarm).

The drive triggers a “DIFF Difference Det” fault and closes the digital output when P4-20 is set to 0 (Fault) The digital output stays closed while the “DIFF Difference Det” fault is active and will open when the difference falls below the P4-18 setting for 1 s or when detection feature is disabled.

The drive triggers the digital output only when P4-10 is set to 2 (Digital Out Only).

### ■ Related Parameters

No.	Parameter Name	Setting Values
P4-18	Differential Level	Default: 10.0 Range: 0.0 to 6000.0
P4-19	Differential Level Detection Time	Default: 10 s Range: 0 to 3600 s
P4-20	Differential Level Detection Selection	Default: 0 Range: 0 to 2
U1-81	Differential PI Feedback	–

#### H2 Multi-Function Digital Output Settings

H2-□□	Function	Description
A1	Differential Det	Closed: The difference between the PID Feedback and the Differential Feedback (H3-□□ = 28) exceeded the P4-18 level for the time set in P4-19.

#### H3 Multi-Function Analog Input Settings (H3-02/H3-06/H3-10)

H3-□□	Function	Description
28	Differential PI Feedback	Full scale: FB Device Scaling (P1-03)

### 4.7 Basic iQpump Setup and Application Preset Parameters

This section explains the basic settings required for initial drive operation. Checking these basic parameter settings will help to ensure a successful drive start-up. *Refer to Parameter List on page 349* for a complete listing of drive parameters if more information is required for parameters not listed in this section.

#### ■ A1-01: Access Level Selection

Allows or restricts access to drive parameters.

No.	Parameter Name	Setting Range	Default
A1-01	Access Level Selection	0 to 3	2

#### Setting 0: Operation only

Access to only parameters A1-01, A1-04, and all U monitor parameters.

#### Setting 1: User Parameters

Access to only a specific list of parameters set to A2-01 through A2-32. These User Parameters can be accessed using the Setup Mode of the digital operator.

#### Setting 2: Advanced Access Level (A) and Setup Access Level (S)

All parameters can be viewed and edited.

#### Setting 3: Lock Parameters

Parameters that are normally visible in the advanced access level (A1-01 = 2) are still visible, but the only parameters that can be changed are A1-01 and A1-04.

The Auto Tuning and Pump Quick Setup menus will not be displayed.

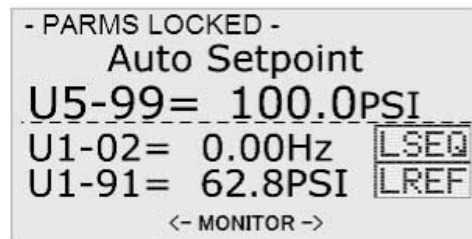

Figure 4.29 Help Message Example (Optional HOA Keypad, JVOP-183, Home Screen)

#### Notes on Parameter Access

- If the drive parameters are password protected by A1-04 and A1-05, parameters A1-00 through A1-03, A1-06, and all A2 parameters cannot be modified.
- If a digital input terminal programmed for “Program lockout” (H1-□□ = 1B) is enabled, parameter values cannot be modified, even if A1-01 is set to 1 or 2.
- If parameters are changed via serial communication, it will not be possible to edit or change parameter settings with the digital operator until an Enter command is issued to the drive from the serial communication.

#### ■ A1-03: Initialize Parameters

Resets parameters to default values or performs an Application Preset for fan or pump applications. After initialization, the setting for A1-03 automatically returns to 0.

No.	Parameter Name	Setting Range	Default
A1-03	Initialize Parameters	0, 1110, 2220, 3330, 5550, 6008, 6009, 6010, 6011, 6012, 6013, 6014, 7770, 7771 <b>Note:</b> A1-03 is initially set to "6008" from the factory, although the keypad will always display "0".	0

- Note:**
- Settings 6012 and 6013 are available in drive software versions PRG: 8552 and later.
  - Setting 6014 is available in drive software versions PRG: 8553 and later.
  - Settings 6012, 6013, and 6014 are not available in drive models 4A0930 and 4A1200.

**Setting 1110: User Initialize**

Resets parameters to the values selected by the user as User Settings. User Settings are stored when parameter o2-03 is set to "1: Set defaults".

- Note:** User Initialization resets all parameters to a user-defined set of default values previously saved to the drive. Set parameter o2-03 to 2 to clear the user-defined default values.

**Setting 2220: 2-Wire Initialization**

Resets parameters to default settings with digital inputs S1 and S2 configured as Forward run and Reverse run, respectively.

**Setting 3330: 3-Wire Initialization**

Resets parameters to default settings with digital inputs S1, S2, and S5 configured as Run, Stop, and Forward/Reverse respectively.

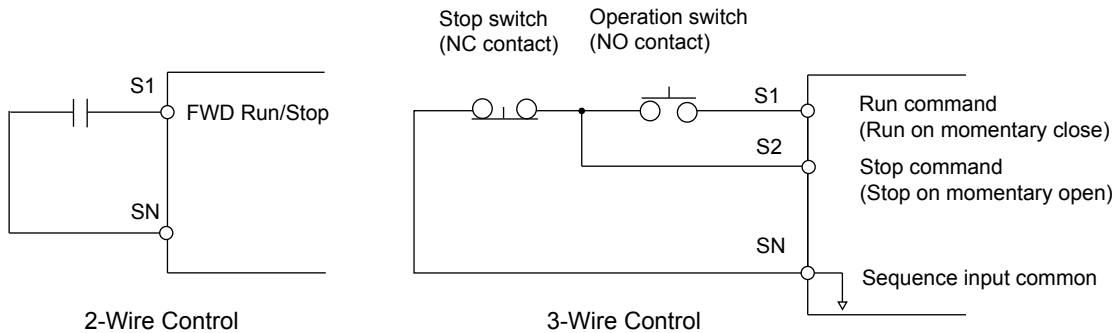

Figure 4.30 2 & 3-Wire Control Wiring Examples

**Notes on Parameter Initialization**

The parameters shown in [Table 4.17](#) will not be reset when the drive is initialized by setting A1-03 = 2220 or 3330.

Table 4.17 Parameters Not Changed by Drive Initialization

No.	Parameter Name
A1-00	Language Selection
E1-03	V/f Pattern Selection
F6-08	Communication Parameter Reset
L8-35	Installation Selection
o2-04	Drive/kVA Selection

**Setting 5550: Terminal/Control Initialize**

An oPE04 error appears on the digital operator when a terminal block with settings saved to its built-in memory is installed in a drive that has edited parameters. Set A1-03 to 5550 to use the parameter settings saved to the terminal block memory.

Application Presets are available to facilitate drive setup for commonly used applications. Selecting one of these Application Presets automatically assigns functions to the input and output terminals and sets a predefined group of parameters to values appropriate for the selected application.

## 4.7 Basic iQpump Setup and Application Preset Parameters

In addition, the parameters most likely to be changed are assigned to the group of User Parameters, A2-01 through A2-16. User Parameters are part of the Setup Group, which provides quicker access by eliminating the need to scroll through multiple menus.

*Refer to Pump Application Presets on page 146* for detailed information on Application Presets.

### Setting 6008: Pressure Control

Application Preset for Pressure Control applications. *Refer to Pump Application Presets on page 146* for a list of parameters and default values for this Application Preset.

### Setting 6009: Pump Down Level

Application Preset for Pump Down Level applications. *Refer to Pump Application Presets on page 146* for a list of parameters and default values for this Application Preset.

### Setting 6010: Geothermal Mode

Application Preset for Geothermal Mode. *Refer to Pump Application Presets on page 146* for a list of parameters and default values for this Application Preset.

### Setting 6011: VTC Pressure Mode

Application Preset for VTC Pressure Mode. *Refer to Pump Application Presets on page 146* for a list of parameters and default values for this Application Preset.

### Setting 6012: Pivot Panel VTC

Application Preset for Pivot Panel VTC. *Refer to Pump Application Presets on page 146* for a list of parameters and default values for this Application Preset.

- Note:**
1. This setting is available in drive software versions PRG: 8552 and later.
  2. This setting is not available in drive models 4A0930 and 4A1200.

### Setting 6013: Advanced Pressure Control

Application Preset for Advanced Pressure Control. *Refer to Pump Application Presets on page 146* for a list of parameters and default values for this Application Preset.

- Note:**
1. This setting is available in drive software versions PRG: 8552 and later.
  2. This setting is not available in drive models 4A0930 and 4A1200.

### Setting 6014: Pivot Panel Submersible

Application Preset for Pivot Panel Submersible Control. *Refer to Pump Application Presets on page 146* for a list of parameters and default values for this Application Preset.

- Note:**
1. This setting is available in drive software versions PRG: 8553 and later.
  2. This setting is not available in drive models 4A0930 and 4A1200.

### Setting 7770: General Purpose

General Purpose Application Preset. *Refer to Pump Application Presets on page 146* for a list of parameters and default values for this Application Preset.

### Setting 7771: Submersible Motor General Purpose Operation

General Purpose Application Preset. *Refer to Pump Application Presets on page 146* for a list of parameters and default values for this Application Preset.

## ■ A1-08: Custom Initialize Modes

*Refer to Parameters Set Depending on A1-08 Setting on page 148* and *Refer to Parameters Displayed Depending on A1-08 Setting on page 149* for details.

- Note:**
1. This parameter is available in drive software versions PRG: 8552 and later.
  2. This parameter is not available in drive models 4A0930 and 4A1200.

No.	Parameter Name	Setting Range	Default
A1-08	Custom Initialize Modes	0, 3005, 3006	0

0: No Initialization

3005: General Ext HOA

AUTO Run = S1,  
 Speed = A2  
 HAND1 Run = S6,  
 Speed = A1  
 HAND2 Run = S7,  
 Speed = P5-05 or Operator  
 Switch to Net Coms = S8;  
 AUTO Run = Serial Run,  
 Speed = Serial Comms

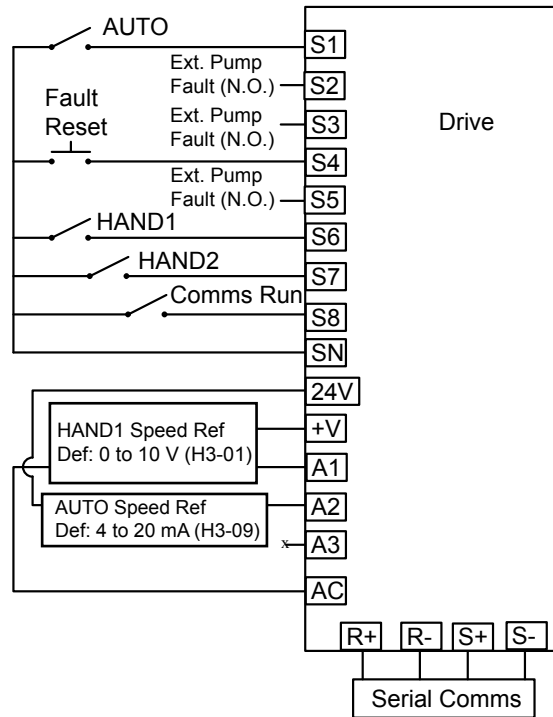

Figure 4.31 Default Port Configuration for General Ext HOA

## 4.7 Basic iQpump Setup and Application Preset Parameters

### 3006: General HOA Keys

AUTO Run = AUTO key + S1,  
 Speed = A2  
 HAND1 Run = S6,  
 Speed = P5-02  
 or Operator when P5-01 = 1,  
 otherwise Terminal A1  
 HAND2 Run = S7,  
 Speed = P5-05 or Operator

Switch to Net Coms = S8;  
 AUTO Run = Auto key + Serial Run,  
 Speed = Serial Comms

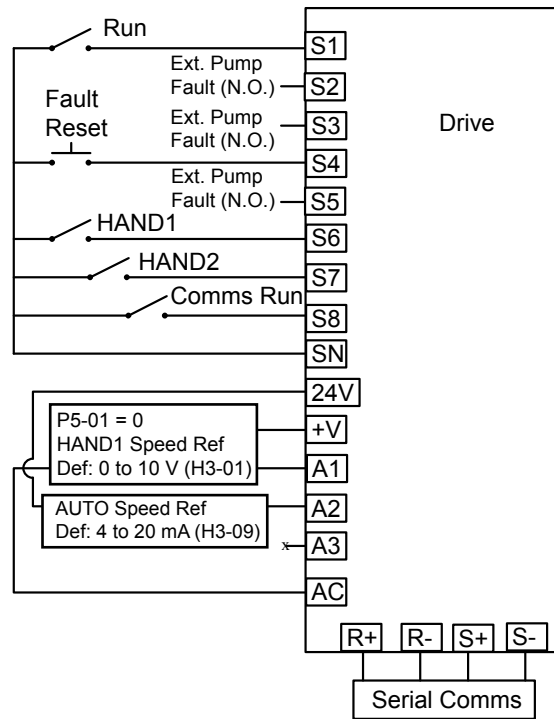

Figure 4.32 Default Port Configuration for General HOA Keys

### ■ b1-01: Frequency Reference Selection 1

Selects the frequency reference source 1 for the REMOTE mode.

**Note:** If a Run command is input to the drive but the frequency reference entered is 0 or below the minimum frequency, the RUN indicator LED on the digital operator will light and the STOP indicator will flash.

No.	Parameter Name	Setting Range	Default
b1-01	Frequency Reference Selection 1	0 to 5	0

In order to run the drive and motor, the drive must receive a Run command and an Auto Setpoint command. Parameter b1-01 specifies the origin of the Auto setpoint when in AUTO Mode. Switch to AUTO mode by pressing the AUTO button on the HOA keypad while the drive is stopped.

**Note:** If a Run command is input to the drive without a corresponding Auto setpoint, the Run indicator on the HOA keypad will turn on and the STOP indicator on the keypad will blink.

If the drive should follow the “HAND Reference” set by the HOA keypad, use HAND Mode by pressing the HAND key and set P5-01 to “1: Hand Reference (P5-02).” The HAND reference can then be entered into the U1-01 monitor parameter in the “-DRIVE-” Menu.

The drive offers the ability to provide four types of “Auto Setpoint” reference sources. These Auto Setpoint reference sources are determined by the setting of b1-01 and the drive set to AUTO Mode by pressing the AUTO key on the keypad.

Prior to programming, it is recommended to select the system units (P1-02) and the feedback device, Scaling (P1- 03) first. P1-03 will automatically scale the drive setpoint.

Example: P1-02 = 1: PSI

P1-03 = 200, feedback range = 200 PSI.

If the drive should follow an “Auto Set-Point” set by the HOA keypad: Set b1-01 to “0: Operator” (factory default). The Auto setpoint can then be entered into the U1-01 monitor parameter in the “-DRIVE-” menu.

**Setting 0: Operator (HOA keypad)**

Using this setting, the frequency reference can be input by:

- switching between the multi-speed references in the d1-□□ parameters.
- entering the frequency reference on the operator keypad.

This selection will also switch PID setpoint to Q1-01.

**Setting 1: Terminals (analog input terminals)**

Using this setting, an analog frequency reference can be entered as a voltage or current signal from terminals A1, A2, or A3. To set the drive to follow an “Auto Setpoint” set by the analog input, set b1-01 to 1 (Terminals) and connect a potentiometer or external signal to the drive.

**Note:** When b1-01 is set to 1 (Terminals) and P5-01 is set to 0 (HAND Mode Reference), the setpoint and the HAND reference are determined by the external analog signal.

**Voltage Input**

Voltage input can be used at any of the three analog input terminals. Make the settings as described in [Table 4.18](#) for the input used.

**Table 4.18 Analog Input Settings for Frequency Reference Using Voltage Signals**

Terminal	Signal Level	Parameter Settings				Notes
		Signal Level Selection	Function Selection	Gain	Bias	
A1	0 to 10 Vdc	H3-01 = 0	H3-02 = 0 (Frequency Reference Bias)	H3-03	H3-04	-
	0 to 10 Vdc Bipolar	H3-01 = 1				
A2	0 to 10 Vdc	H3-09 = 0	H3-10 = 0 (Frequency Reference Bias)	H3-11	H3-12	Set jumper S1 on the terminal board to “V” for voltage input.
	0 to 10 Vdc Bipolar	H3-09 = 1				
A3	0 to 10 Vdc	H3-05 = 0	H3-06 = 0 (Frequency Reference Bias)	H3-07	H3-08	Set DIP switch S4 on the terminal board to “AI”.
	0 to 10 Vdc Bipolar	H3-05 = 1				

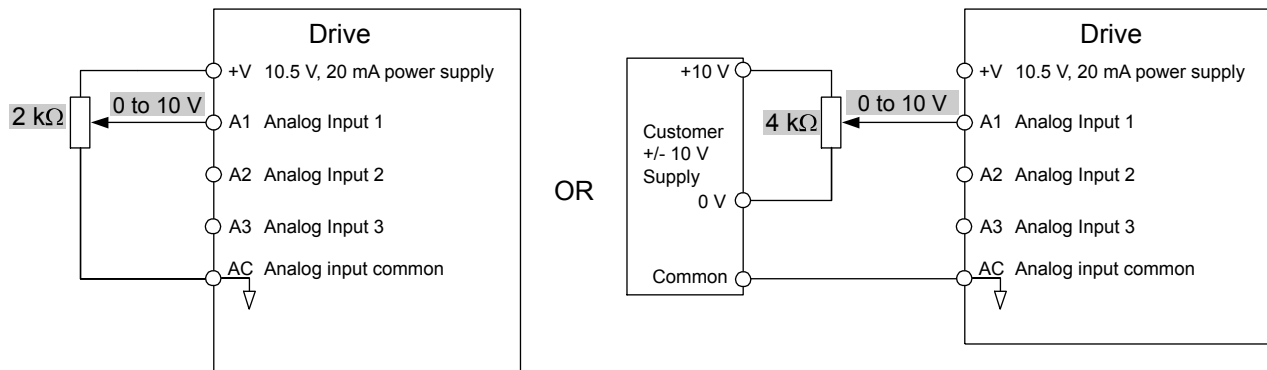

**Figure 4.33 Setting the Frequency Reference as a Voltage Signal at Terminal A1**

**Current Input**

Input terminals, A1, A2, and A3 can accept a current input signal. Refer to [Table 4.19](#) for an example to set terminal A2 for current input.

**Table 4.19 Analog Input Settings for Frequency Reference Using a Current Signal**

Terminal	Signal Level	Parameter Settings				Notes
		Signal Level Selection	Function Selection	Gain	Bias	
A2	4 to 20 mA	H3-09 = 2	H3-10 = 0 (Frequency Bias)	H3-11	H3-12	Make sure to set jumper S1 on the terminal board to “I” for current input.
	0 to 20 mA	H3-09 = 3				

## 4.7 Basic iQpump Setup and Application Preset Parameters

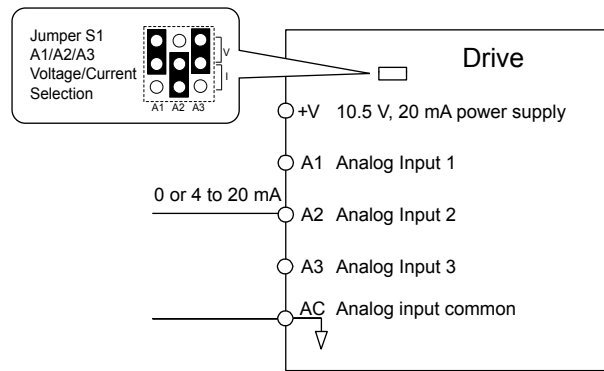

Figure 4.34 Setting the Frequency Reference as a Current Signal to Terminal A2

### Switching between Main/Auxiliary Frequency References

The frequency reference input can be switched between the analog terminals A1, A2, and A3 using multi-speed inputs. To use several speed references for a multi-step speed sequence, set the H1-□□ parameters to 3, 4, 5, and 32. To assign the Jog reference to a digital input, set H1-□□ to 6.

### Setting 2: Serial Communications

This setting requires entering the frequency reference via the RS-485/422 serial communications port (control terminals R+, R-, S+, S-).

To setup the drive to receive the “Auto Setpoint” from serial communication, set b1-01 to “2: Serial Com,” and connect the RS-422/RS-485 serial communications cable to terminals R+, R-, S+, and S- on the control I/O terminal block. Refer to [216](#) to see the connection diagram using a PC to provide the auto setpoint reference to the drive.

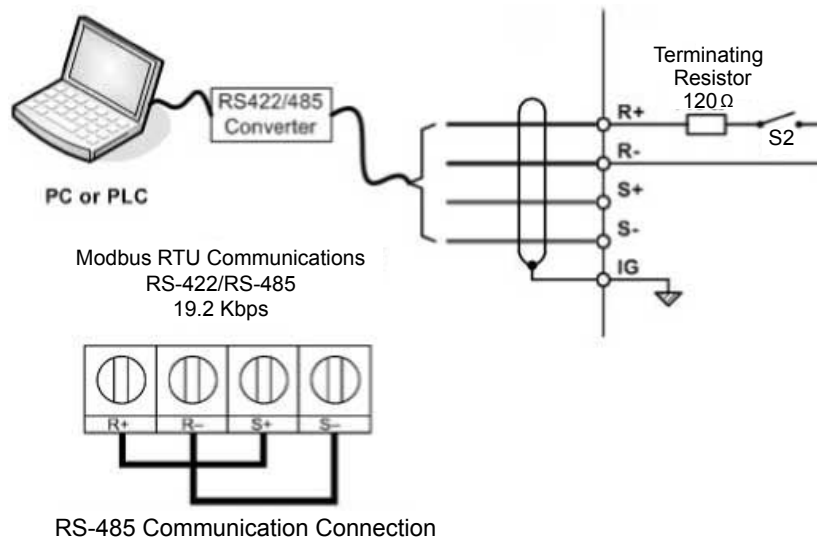

Figure 4.35 PC or PLC Connection Diagram

### Setting 3: Option card

This setting requires entering the frequency reference via an option board plugged into connector CN5-A on the drive control board. Consult the option board manual for instructions on integrating the drive with the communication system.

**Note:** If the frequency reference source is set for Option PCB (b1-01 = 3), but an option board is not installed, an oPE05 Operator Programming Error will be displayed on the digital operator and the drive will not run.

To setup the drive to receive the “Auto Setpoint” for a network communication option card, set b1-01 to “3: Option PCB”, and plug a supported communication option card into the drive control PCB. Consult the manual supplied with the option for instructions on integrating the drive into the network system.

[Refer to Option Installation on page 310](#) for a list of available drive network communication options.



**Setting 4: Pulse Train Input**

This setting requires a pulse train signal to terminal RP to provide the frequency reference. Follow the directions below to verify that the pulse signal is working properly.

**Verifying the Pulse Train is Working Properly**

- Set b1-04 to 4 and set H6-01 to 0.
- Set the H6-02 to the pulse train frequency value that equals 100% of the frequency reference.
- Enter a pulse train signal to terminal RP and check for the correct frequency reference on the display.

**Setting 5: Geothermal Mode**

*Refer to Geothermal Mode Application Preset on page 154* for details on how to use this function.

**■ b1-02: Run Command Selection 1**

Determines the Run command source 1 in AUTO Mode.

The drive comes factory programmed for Start and Stop from the keypad, but the user can program the drive to receive a Run command from four different inputs: digital operator, terminals, serial communications, or an option PCB.

To set the drive to receive the Run command from the HOA keypad, set b1-02 to “0: Operator,” and the HAND key will be used to provide the Run command to the drive.

To set the drive to receive the Run command from the external terminals, set b1-02 to “1: Terminals” and initiate an external Run command by a contact closure between terminals S1 and SN.

**Note:** Using the external terminals requires setting the drive to AUTO Mode by pressing the AUTO key.

No.	Parameter Name	Setting Range	Default
b1-02	Run Command Selection 1	0 to 3; 6 to 8	0

- Note:**
1. Settings 6 to 8 are available in drive software versions PRG: 8552 and later.
  2. Settings 6 to 8 are not available in drive models 4A0930 and 4A1200.

**Setting 0: Operator (HOA keypad)**

This setting requires entering the Run command via the HOA keypad AUTO key and also illuminates the HAND indicator on the digital operator.

**Setting 1: Control Circuit Terminal**

This setting requires entering the Run command via the digital input terminals using one of following sequences:

- 2-Wire sequence 1:  
Two inputs (FWD/Stop-REV/Stop). Set A1-03 to 2220 to initialize the drive and preset terminals S1 and S2 to these functions. This is the default setting of the drive.
- 2-Wire sequence 2:  
Two inputs (Start/Stop-FWD/REV).
- 3-Wire sequence:  
Three inputs (Start-Stop-FWD/REV). Set A1-03 to 3330 to initialize the drive and preset terminals S1, S2, and S5 to these functions.

**Setting 2: MEMOBUS/Modbus Communications**

This setting requires entering the Run command via serial communications by connecting the RS-485/422 serial communication cable to control terminals R+, R-, S+, and S- on the removable terminal block.

**Setting 3: Option Card**

This setting requires entering the Run command via the communication option board by plugging a communication option board into the CN5-A port on the control PCB. Refer to the option board manual for instructions on integrating the drive into the communication system.

**Note:** If b1-02 is set to 3, but an option board is not installed in CN5-A, an oPE05 operator programming error will be displayed on the digital operator and the drive will not run.

**Setting 6: AUTOKey + Term**

When b1-02/b1-16 = 6, the AUTO key puts the drive into AUTO mode and the terminal programmed for Run (H1-□□ = 40, 41, or 42) acts as the External Run command.

**Note:** Available in drive software versions PRG: 8552 and later.

**Note:** 1. Setting available in drive software versions PRG: 8552 and later.

## 4.7 Basic iQpump Setup and Application Preset Parameters

- Setting not available in drive models 4A0930 and 4A1200.

### Setting 7: AUTOKey + Serial

When b1-02/b1-16 = 7, the AUTO key puts the drive into AUTO mode and the Serial Run command (register 0001) acts as the External Run command.

- Note:**
- Setting available in drive software versions PRG: 8552 and later.
  - Setting not available in drive models 4A0930 and 4A1200.

### Setting 8: AUTOKey + Option

When b1-02/b1-16 = 8, the AUTO key puts the drive into AUTO mode and the Option Card Run command acts as the External Run command.

- Note:**
- Setting available in drive software versions PRG: 8552 and later.
  - Setting not available in drive models 4A0930 and 4A1200.

## ■ b1-03: Stopping Method Selection

Selects how the drive stops the motor when the Run command is removed or when a Stop command is entered.

- Note:** Parameter b1-11, Run Delay at Stop (Back Spin Timer), is effective for all stopping methods (b1-03 = 0 to 3), not only Coast to Stop w/ Timer (b1-03 =3).

No.	Parameter Name	Setting Range	Default
b1-03	Stopping Method Selection	0 to 3	1

### Setting 0: Ramp to Stop

When the Run command is removed, the drive will decelerate the motor to stop. The deceleration rate is determined by the active deceleration time. The default deceleration time is set to parameter C1-02.

When the output frequency falls below the level set in parameter b2-01, the drive will start DC injection, Zero Speed Control, or Short Circuit Braking.

### Setting 1: Coast to Stop

When the Run command is removed, the drive will shut off its output and the motor will coast (uncontrolled deceleration) to stop. The stopping time is determined by the inertia and the friction in the driven system.

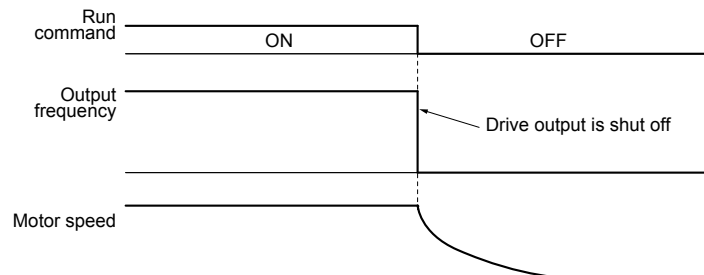

Figure 4.36 Coast to Stop

- Note:** After a stop is initiated, any subsequent Run command entered will be ignored until the minimum baseblock time (L2-03) has expired. Do not enter Run command until it has come to a complete stop. Use DC Injection at Start ([Refer to b2: DC Injection Braking and Short Circuit Braking on page 354](#)) or Speed Search ([Refer to b3: Speed Search on page 354](#)) to restart the motor before it has completely stopped.

### Setting 2: DC Injection Braking to Stop

When the Run command is removed, the drive will enter baseblock (turn off its output) for the minimum baseblock time (L2-03). When the minimum baseblock time has expired, the drive will inject the amount DC Injection Braking is set in parameter b2-02 into the motor windings to brake the motor. The stopping time in DC Injection Braking to Stop is significantly faster compared to Coast to Stop.

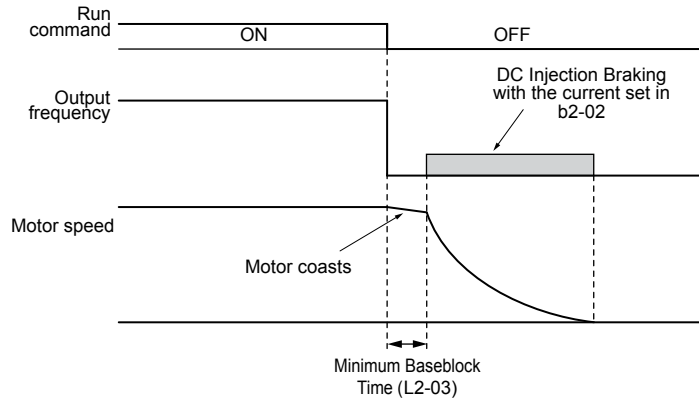

Figure 4.37 DC Injection Braking to Stop

DC Injection Braking time is determined by the value set to b2-04 and the output frequency at the time the Run command is removed. It can be calculated by:

$$\text{DC Injection brake time} = \frac{(b2-04) \times 10 \times \text{Output frequency}}{\text{Maximum output frequency (E1-04)}}$$

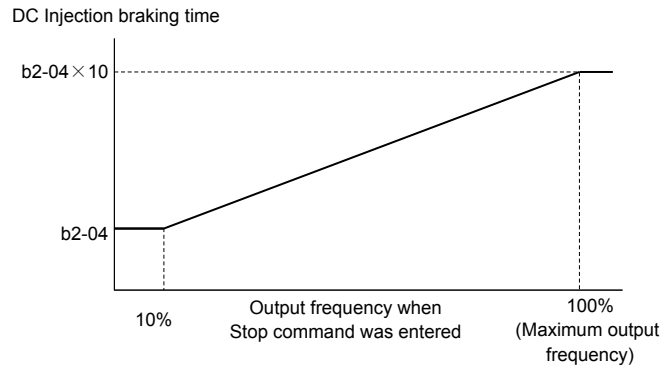

Figure 4.38 DC Injection Braking Time Depending on Output Frequency

**Note:** If an overcurrent (oC) fault occurs during DC Injection Braking to Stop, lengthen the minimum baseblock time (L2-03) until the fault no longer occurs.

**Setting 3: Coast to Stop with Timer (Used for Back Spin Control on Vertical Turbine Pumps)**

When the Run command is removed, the drive coasts to a stop. If parameter b1-11 is set to zero, the coast-timer (Run Delay at Stop) becomes a value determined by a combination of output frequency and the C1-02 parameter. However, if b1-11 is set greater than zero, the Run Delay at Stop timer is set to b1-11. If the Run command is reissued during the Run Delay at Stop timer time, the drive WILL restart when the timer expires without the need to cycle the Run command. The Run Delay at Stop timer will operate for both AUTO Mode and HAND Mode. The Run Delay at Stop timer will still operate when the drive goes to sleep and then wakes up. During the Run Delay at Stop timer execution, the HOA keypad will display the alarm “WrUn”. Both Alarm and Run indicators will blink while the drive waits to execute the Run command.

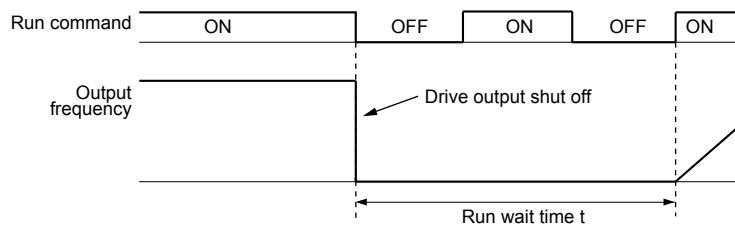

Figure 4.39 Coast to Stop with Timer

The wait time t is determined by the output frequency when the Run command is removed and by the active deceleration time.

## 4.7 Basic iQpump Setup and Application Preset Parameters

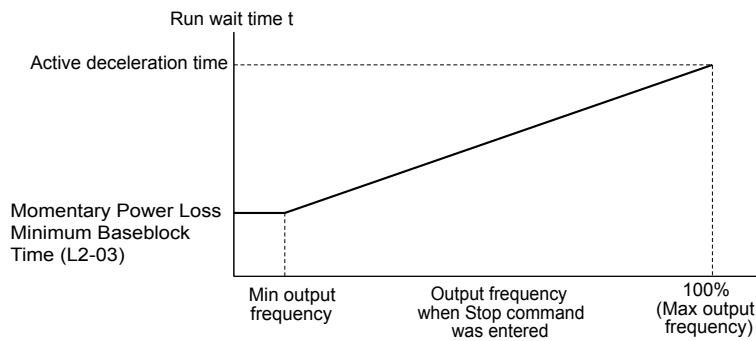

Figure 4.40 Run Wait Time Depending on Output Frequency

### ■ b3-01: Speed Search Selection at Start

Determines if Speed Search is automatically performed when a Run command is issued.

No.	Parameter Name	Setting Range	Default
b3-01	Speed Search Selection at Start	0, 1	0

#### Setting 0: Disabled

This setting starts operating the drive at the minimum output frequency when the Run command is entered. If external Speed Search 1 or 2 is already enabled by a digital input, the drive will start operating with Speed Search.

#### Setting 1: Enabled

This setting performs Speed Search when the Run command is entered. The drive begins running the motor after Speed Search is complete.

### ■ b5-01: PID Function Setting

Enables and disables the PID operation and selects the PID operation mode.

No.	Parameter Name	Setting Range	Default
b5-01	PID Function Setting	0, 1	1

#### Setting 0: PID disabled

#### Setting 1: Output frequency = PID output 1

The PID controller is enabled and the PID output builds the frequency reference. The PID input is D controlled.

### ■ b5-02: Proportional Gain Setting (P)

Sets the P gain applied to the PID input. Larger values will tend to reduce the error but may cause oscillations if set too high, while lower values may allow too much offset between the setpoint and feedback. The function of b5-02 is disabled when P1-24 > 0.

No.	Name	Setting Range	Default
b5-02	Proportional Gain Setting (P)	0.00 to 25.00	2.00

### ■ b5-03: Integral Time Setting (I)

Sets the time constant used to calculate the integral of the PID input. The shorter the integral time set to b5-03, the faster the offset will be eliminated. If the integral time is set too short, however, overshoot or oscillation may occur. To turn off the integral time, set b5-03 to 0.00.

No.	Name	Setting Range	Default
b5-03	Integral Time Setting (I)	0.0 to 360.0 s	1.0 s

### ■ b5-09: PID Output Level Selection

Reverses the sign of the PID controller output signal. Normally a positive PID input (feedback smaller than setpoint) leads to positive PID output.

No.	Parameter Name	Setting Range	Default
b5-09	PID Output Level Selection	0, 1	0

**Setting 0: Normal Output**

A positive PID input causes an increase in the PID output (direct acting).

**Setting 1: Reverse Output**

A positive PID input causes a decrease in the PID output (reverse acting).

■ **b5-39: PID Setpoint User Display, PID Setpoint Display Digits**

Setst a user-defined display for the PID setpoint (b5-19) and PID feedback monitors (U5-01, U5-04). The setting value is equal to the number of decimal places.

No.	Name	Setting Range	Default
b5-39	PID Setpoint Display Digits	0 to 3	1

**Setting 0: No Decimal Places**

**Setting 1: One Decimal Place**

**Setting 2: Two Decimal Places**

**Setting 3: Three Decimal Places**

■ **C1-01 to C1-04: Accel, Decel Times 1 and 2**

Two different sets of acceleration and deceleration times can be set in the drive by digital inputs, motor selection, or switched automatically.

Acceleration time parameters always set the time to accelerate from 0 Hz to the maximum output frequency (E1-04).

Deceleration time parameters always set the time to decelerate from maximum output frequency to 0 Hz. C1-01 and C1-02 are the default active accel/decel settings.

No.	Parameter Name	Setting Range	Default
C1-01	Acceleration Time 1	0.0 to 6000.0 s <I>	10.0 s
C1-02	Deceleration Time 1		
C1-03	Acceleration Time 2		
C1-04	Deceleration Time 2		

<I> The setting range for the acceleration and deceleration times is determined by the accel/decel time setting units in C1-10. For example, if the time is set in units of 0.01 s (C1-10 = 0), the setting range becomes 0.00 to 600.00 s.

**Switching Acceleration Times by Digital Input**

Accel/decel time 1 is active by default if no input is set. Activate accel/decel times 2, 3, and 4 by digital inputs (H1-□□ = 7 and 1A) as explained in [Table 4.20](#).

**Table 4.20 Accel/Decel Time Selection by Digital Input**

Accel/Decel Time Sel. 1 H1-□□ = 7	Accel/Decel Time Sel. 2 H1-□□ = 1A	Active Times	
		Acceleration	Deceleration
0	0	C1-01	C1-02
1	0	C1-03	C1-04

[Figure 4.41](#) shows an operation example for changing accel/decel. times. The example below requires that the stopping method be set for “Ramp to stop” (b1-03 = 0).

## 4.7 Basic iQpump Setup and Application Preset Parameters

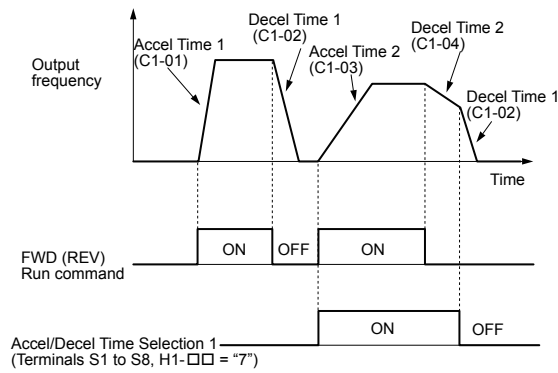

Figure 4.41 Timing Diagram of Accel/Decel Time Change

### ■ E2-01: Motor Rated Current

Provides motor control, protects the motor, and calculates torque limits. Set E2-01 to the full load amps (FLA) stamped on the motor nameplate. If Auto-Tuning completes successfully, the value entered to T1-04 will automatically be saved to E2-01.

No.	Parameter Name	Setting Range	Default
E2-01	Motor Rated Current	10% to 200% of the drive rated current <I>	Determined by o2-04

<I> Display is in the following units:

- 2A0004 to 2A0040, 4A0002 to 4A0023, and 5A0007 to 5A0017: 0.01 A units.
- 2A0056 to 2A0415, 4A0031 to 4A0675, and 5A0022 to 5A0242: 0.1 A units.
- 4A0930 and 4A1200: 1 A units.

**Note:** An oPE02 error will occur if  $E2-01 \leq E2-03$ . Set E2-03 correctly to prevent this error.

### ■ E2-04: Number of Motor Poles

Set the number of motor poles to E2-04. If Auto-Tuning completes successfully, the value entered to T1-06 will automatically be saved to E2-04.

No.	Parameter Name	Setting Range	Default
E2-04	Number of Motor Poles	2 to 48	2

### ■ H1-01 to H1-08: Functions for Terminals S1 to S8

These parameters assign functions to the multi-function digital inputs. The various functions and settings are listed in [Table 4.21](#).

No.	Parameter Name	Setting Range	Default
H1-01	Multi-Function Digital Input Terminal S1 Function Selection	1 to 9F	40 (F) <I> : Forward Run Command (2-Wire sequence)
H1-02	Multi-Function Digital Input Terminal S2 Function Selection	1 to 9F	F: Through Mode
H1-03	Multi-Function Digital Input Terminal S3 Function Selection	0 to 9F	26: External Pump Fault
H1-04	Multi-Function Digital Input Terminal S4 Function Selection	0 to 9F	14: Fault Reset
H1-05	Multi-Function Digital Input Terminal S5 Function Selection	0 to 9F	8D (0) <I> : Multi Setpoint 1
H1-06	Multi-Function Digital Input Terminal S6 Function Selection	0 to 9F	80 (3) <I> : HAND Mode
H1-07	Multi-Function Digital Input Terminal S7 Function Selection	0 to 9F	81 (4) <I> : HAND Mode 2
H1-08	Multi-Function Digital Input Terminal S8 Function Selection	0 to 9F	F (6) <I> : Through Mode

<I> Number appearing in parenthesis is the default value after performing a 3-Wire initialization (A1-03 = 3330).

Table 4.21 Multi-Function Digital Input Terminal Settings

Setting	Function	Page	Setting	Function	Page
0	3-Wire sequence	–	4	Multi-Step Speed Reference 2	–
2	External Reference 1/2 Selection	–	5	Multi-Step Speed Reference 3	–
3	Multi-Step Speed Reference 1	–	6	Jog reference selection	–

## 4.7 Basic iQpump Setup and Application Preset Parameters

Setting	Function	Page	Setting	Function	Page
7	Accel/decel time selection 1	–	62	External Speed Search command 2	–
8	Baseblock command (N.O.)	–	63	Field weakening	–
9	Baseblock command (N.C.)	–	65	KEB Ride-Thru 1 (N.C.)	–
A	Accel/decel ramp hold	–	66	KEB Ride-Thru 1 (N.O.)	–
B	Drive overheat alarm (oH2)	–	67	Communications test mode	–
C	Analog terminal input selection	–	68	High Slip Braking (HSB)	–
F	Through mode	–	6A	Drive enable	–
10	Up command	–	73	Low City Press	–
11	Down command	–	75	Up 2 command	–
12	Forward Jog	–	76	Down 2 command	–
13	Reverse Jog	–	7A	KEB Ride-Thru 2 (N.C.)	–
14	Fault reset	–	7B	KEB Ride-Thru 2 (N.O.)	–
15	Fast Stop (N.O.)	–	80	HAND Mode	–
17	Fast Stop (N.C.)	–	81	HAND Mode 2	–
18	Timer function input	–	82 <1>	PI Switch to Aux	–
19	PID disable	–	83	Alternate Multi-Setpoint (Q1-02)	–
1A	Accel/decel time selection 2	–	84	Alternate Multi-Setpoint (Q1-03)	–
1B	Program lockout	–	85	Alternate Multi-Setpoint (Q1-04)	–
1E	Reference sample hold	–	88	Volute-Thermostat Normally Open	–
20 to 2F	Ext. pump fault	–	89	Volute-Thermostat Normally Closed	–
30	PID integral reset	–	8C	Disable Pre-Charge	–
31	PID integral hold	–	8D	Multi Setpoint 1	–
32	Multi-Step Speed Reference 4	–	8E	Multi Setpoint 2	–
34	PID soft starter cancel	–	8F	Low Water Level	–
35	PID input level selection	–	90	High Water Level	–
40	Forward run command (2-Wire sequence)	–	92	Reset Accum	–
41	Reverse run command (2-Wire sequence)	–	95	Remove Drive Disable	–
42	Run command (2-Wire sequence 2)	–	A8	Secondary PI Disable (N.O.)	–
43	FWD/REV command (2-Wire sequence 2)	–	A9	Secondary PI Disable (N.C.)	–
47	Node setup	–	AA	Secondary PI Inverse Operation	–
51	Sequence Timer Disable	–	AB	Secondary PI Integral Reset	–
52	Sequence Timer Cancel	–	AC	Secondary PI Integral Hold	–
60	DC Injection Braking command	–	AD	Select Secondary PI Parameters	–
61	External Speed Search command 1	–	AF	Emergency Override Forward Run	–
			B0	Emergency Override Reverse Run	–

<1> Available in drive software versions PRG: 8552 and later.  
Not available in drive models 4A0930 and 4A1200.

### ■ H2-01 to H2-03: Terminal M1-M2, M3-M4, and MD-ME-MF Function Selection

The drive has three multi-function output terminals. [Table 4.22](#) lists the functions available for these terminals using H2-01, H2-02, and H2-03.

No.	Parameter Name	Setting Range	Default
H2-01	Terminal M1-M2 Function Selection (relay)	0 to 192	37: During Frequency Output
H2-02	Terminal M3-M4 Function Selection (relay)	0 to 192	42: Pressure Reached <1>
H2-03	Terminal MD-ME-MF Function Selection (relay)	0 to 192	E: Fault

<1> Default is F: Through Mode in drive software versions PRG: 8551 and earlier.

## 4.7 Basic iQpump Setup and Application Preset Parameters

Table 4.22 Multi-Function Digital Output Terminal Settings

Setting	Function	Page	Setting	Function	Page
0	During run	–	4D	oH Pre-alarm time limit	–
1	Zero speed	–	4E <2>	Braking transistor fault (rr)	–
2	Speed agree 1	–	4F <2>	Braking resistor overheat (oH)	–
3	User-set speed agree 1	–	51	Sequence timer 1	–
4	Frequency detection 1	–	52	Sequence timer 2	–
5	Frequency detection 2	–	53	Sequence timer 3	–
6	Drive ready	–	54	Sequence timer 4	–
7	DC bus undervoltage	–	58	Underload detection	–
8	During baseblock (N.O.)	–	60	Internal cooling fan alarm	–
9	Frequency reference source	–	71	Secondary PI Feedback Low	–
A	Run command source	–	72	Secondary PI Feedback High	–
A	HAND Mode	–	80	Pump 2 Control	–
B	Torque detection 1 (N.O.)	–	81	Pump 3 Control	–
C	Frequency reference loss	–	82	Pump 4 Control	–
D <1>	Braking resistor fault	–	83	Pump 5 Control	–
E	Fault	–	84	Pump 6 Control	–
F	Through mode	–	89	Output 1 Limit	–
10	Minor fault	–	8B	Lube Pump or Digital Output Delay	–
11	Fault reset command active	–	8F	Internal Fan On	–
12	Timer output	–	91	Pump Fault	–
13	Speed agree 2	–	92	Transducer Loss	–
14	User-set speed agree 2	–	93	Setpoint Not Met	–
15	Frequency detection 3	–	94	Loss of Prime	–
16	Frequency detection 4	–	95	Volute Thermostat Fault	–
17	Torque detection 1 (N.C.)	–	96	High Feedback	–
18	Torque detection 2 (N.O.)	–	97	Low Feedback	–
19	Torque detection 2 (N.C.)	–	98	Low Flow	–
1A	During reverse	–	99	Accum Level	–
1B	During baseblock (N.C.)	–	9A	High Flow	–
1E	Restart enabled	–	9B	Low Water Level	–
1F	Motor overload alarm (oL1)	–	9C	Low Suction	–
20	Drive overheat pre-alarm (oH)	–	9D	High Suction	–
22	Mechanical weakening detection	–	9E	Low PI Aux Level	–
2F	Maintenance period	–	9F	High PI Aux Level	–
30	During torque limit	225	A0	Water Loss/Suction Pressure/PI Aux Control	–
37	During frequency output	–	A1	Differential Detected	–
38	Drive enabled	–	A2	Sleep Active	–
39	Watt hour pulse output	–	A3	Start Delay	–
3D	During speed search	–	A4	Pre-Charge	–
3E	PID feedback low	–	A5	Anti-Jam Active	–
3F	PID feedback high	–	A6	De-Scale Active	–
40	Auto Mode	–	A7	Flow Rate Limit	–
42	Pressure Reached	225	A9	Thrust Mode	–
43	2 Motor Alternate	–	AA	Utility Start Delay	–
4A	During KEB Ride-Thru	–	100 to 1AA	Function 0 to AA with inverse output	–
4C	During fast stop	–			

<1> Not available in models 4A0930 and 4A1200.

<2> Not available in models 2A0169 to 2A0415 and 4A0088 to 4A1200.



**Setting 30: During Torque Limit**

The output closes when the motor is operating at the torque limit specified by the L7-□□ parameters or an analog input. This setting can only be used in OLV control mode.

**Setting 42: Pressure Reached**

- Note:**
1. Setting available in drive software versions PRG: 8552 and later.
  2. Setting not available in drive models 4A0930 and 4A1200.

Pressure Setpoint has been reached. Activation and deactivation conditions based on the Pressure Feedback and the settings of P4-36 to P4-40.

**Direct-acting PID**

The terminal activates when the feedback meets or exceeds the setpoint for the time set in P4-38.

The terminal deactivates based on the hysteresis level (P4-37), delay time (P4-39), and the pressure reached exit conditions (P4-36).

When P4-36 = 0 (Hysteresis Above & Below), the terminal deactivates when the feedback falls below the setpoint – hysteresis level or when it rises above the setpoint + hysteresis level for the time set in P4-39.

When P4-36 = 1 (Hysteresis 1-Way), the terminal only deactivates when the feedback falls below the setpoint – hysteresis level for the time set in P4-39.

**Inverse-acting PID**

The terminal activates when the feedback meets or falls below the setpoint for the time set in P4-20.

The terminal deactivates based on the hysteresis level (P4-37), delay time (P4-39), and the pressure reached exit conditions (P4-36).

When P4-36 = 0 (Hysteresis Above & Below), the terminal deactivates when the feedback falls below the setpoint – hysteresis level or when it rises above the setpoint + hysteresis level for the time set in P4-39.

When P4-36 = 1 (Hysteresis 1-Way), the terminal only deactivates when the feedback rises above the setpoint + hysteresis level for the time set in P4-39.

**■ H3-01: Terminal A1 Signal Level Selection**

Selects the input signal level for analog input A1.

No.	Name	Setting Range	Default
H3-01	Terminal A1 Signal Level Selection	0 to 3	0

**Setting 0: 0 to 10 Vdc**

The input level is 0 to 10 Vdc. The minimum input level is limited to 0%, so that a negative input signal due to gain and bias settings will be read as 0%.

**Setting 1: 0 to 10 Vdc Bipolar**

The input level is -10 to 10 Vdc. If the resulting voltage is negative after being adjusted by gain and bias settings, then the motor will rotate in reverse.

**Setting 2: 4 to 20 mA****Setting 3: 0 to 20 mA****■ H3-02: Terminal A1 Function Selection**

Selects the input signal level for analog input A1.

No.	Name	Setting Range	Default
H3-02	Terminal A1 Function Selection	0 to 26	0

**■ H3-03, H3-04: Terminal A1 Gain and Bias Settings**

Parameter H3-03 sets the level of the selected input value that is equal to 10 Vdc input at terminal A1 (gain).

Parameter H3-04 sets the level of the selected input value that is equal to 0 V input at terminal A1 (bias).

Use both parameters to adjust the characteristics of the analog input signal to terminal A1.

## 4.7 Basic iQpump Setup and Application Preset Parameters

No.	Name	Setting Range	Default
H3-03	Terminal A1 Gain Setting	-999.9 to 999.9%	100.0%
H3-04	Terminal A1 Bias Setting	-999.9 to 999.9%	0.0%

### Setting Examples

- Gain H3-03 = 200%, bias H3-04 = 0, terminal A1 as frequency reference input (H3-02 = 0):

A 10 Vdc input is equivalent to a 200% frequency reference and 5 Vdc is equivalent to a 100% frequency reference. Since the drive output is limited by the maximum frequency parameter (E1-04), the frequency reference will be equal to E1-04 above 5 Vdc.

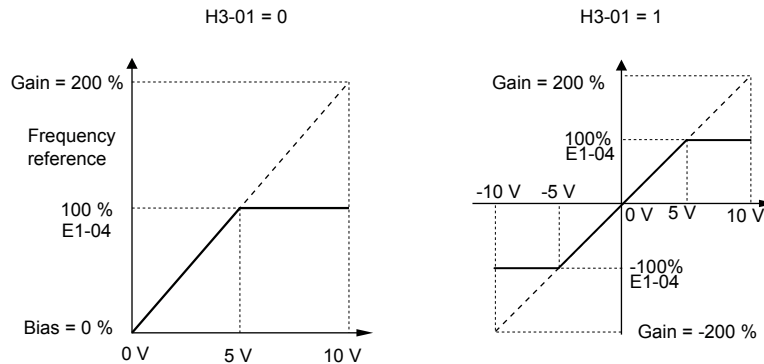

Figure 4.42 Frequency Reference Setting by Analog Input with Increased Gain

- Gain H3-03 = 100%, bias H3-04 = -25%, terminal A1 as frequency reference input:

An input of 0 Vdc will be equivalent to a -25% frequency reference.

When parameter H3-01 = 0, the frequency reference is 0% between 0 and 2 Vdc input.

When parameter H3-01 = 1, the motor will rotate in reverse between -10 and 2 Vdc input.

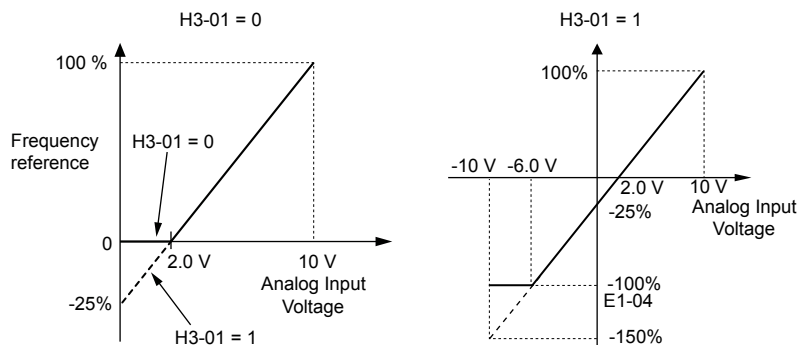

Figure 4.43 Frequency Reference Setting by Analog Input with Negative Bias

### ■ H3-05: Terminal A3 Signal Level Selection

Determines the function assigned to analog input terminal A3.

No.	Name	Setting Range	Default
H3-05	Terminal A3 Signal Level Selection	0 to 3	0

#### Setting 0: 0 to 10 Vdc

The input level is 0 to 10 Vdc. See the explanation provided for H3-01. [Refer to Setting 0: 0 to 10 Vdc on page 225.](#)

#### Setting 1: 0 to 10 Vdc Bipolar

The input level is -10 to 10 Vdc. See the explanation provided for H3-01. [Refer to Setting 1: 0 to 10 Vdc Bipolar on page 225.](#)

**Setting 2: 4 to 20 mA**

**Setting 3: 0 to 20 mA**

### ■ H3-06: Terminal A3 Function Selection

Determines the function assigned to analog input terminal A3.

No.	Name	Setting Range	Default
H3-06	Terminal A3 Function Selection	0 to 31	20

### ■ H3-07, H3-08: Terminal A3 Gain and Bias Setting

Parameter H3-07 sets the level of the selected input value that is equal to 10 Vdc input at terminal A3 (gain).

Parameter H3-08 sets the level of the selected input value that is equal to 0 V input at terminal A3 (bias).

No.	Name	Setting Range	Default
H3-07	Terminal A3 Gain Setting	-999.9 to 999.9%	100.0%
H3-08	Terminal A3 Bias Setting	-999.9 to 999.9%	0.0%

### ■ H3-09: Terminal A2 Signal Level Selection

Selects the input signal level for analog input A2. Set Jumper S1 on the terminal board accordingly for a voltage input or current input.

No.	Name	Setting Range	Default
H3-09	Terminal A2 Signal Level Selection	0 to 3	2

**Setting 0: 0 to 10 Vdc**

The input level is 0 to 10 Vdc. *Refer to Setting 0: 0 to 10 Vdc on page 225.*

**Setting 1: 0 to 10 Vdc Bipolar**

The input level is -10 to 10 Vdc. *Refer to Setting 1: 0 to 10 Vdc Bipolar on page 225.*

**Setting 2: 4 to 20 mA**

The input level is 4 to 20 mA. Negative input values by negative bias or gain settings will be limited to 0%.

**Setting 3: 0 to 20 mA**

The input level is 0 to 20 mA. Negative input values by negative bias or gain settings will be limited to 0%.

### ■ H3-10: Terminal A2 Function Selection

Determines the function assigned to analog input terminal A2.

No.	Name	Setting Range	Default
H3-10	Terminal A2 Function Selection	0 to 32	B

### ■ H3-11, H3-12: Terminal A2 Gain and Bias Setting

Parameter H3-11 sets the level of the input value selected that is equal to 10 Vdc input or 20 mA input to terminal A2.

Parameter H3-12 sets the level of the input value selected that is equal to 0 V, 4 mA or 0 mA input at terminal A2.

Use both parameters to adjust the characteristics of the analog input signal to terminal A2. The setting works in the same way as parameters H3-03 and H3-04 for analog input A1.

No.	Name	Setting Range	Default
H3-11	Terminal A2 Gain Setting	-999.9 to 999.9%	100.0%
H3-12	Terminal A2 Bias Setting	-999.9 to 999.9%	0.0%

### ■ H4-01, H4-04: Multi-Function Analog Output Terminal FM, AM Monitor Selection

Sets the desired drive monitor parameter U□-□□ to output as an analog value via terminal FM and AM. *Refer to U1: Operation Status Monitors on page 437* for a list of all monitors. The “Analog Output Level” column indicates whether a monitor can be used for analog output.

Example: Enter “103” for U1-03.

## 4.7 Basic iQpump Setup and Application Preset Parameters

No.	Name	Setting Range	Default
H4-01	Multi-Function Analog Output Terminal FM Monitor Selection	000 to 999	102
H4-04	Multi-Function Analog Output Terminal AM Monitor Selection	000 to 999	103

A setting of 031 or 000 applies no drive monitor to the analog output. With either of these settings, the output level of the terminals FM and AM can be set by a PLC via a communication option or MEMOBUS/Modbus (through mode).

### ■ H4-02, H4-03: Multi-Function Analog Output Terminal FM Gain and Bias H4-05, H4-06: Multi-Function Analog Output Terminal AM Gain and Bias

Parameters H4-02 and H4-05 set the terminal FM and AM output signal level when the value of the selected monitor is at 100%. Parameters H4-03 and H4-06 set the terminal FM and AM output signal level when the value of the selected monitor is at 0%. Both are set as a percentage, where 100% equals 10 Vdc or 20 mA analog output and 0% equals 0 V or 4 mA. The output voltage of both terminals is limited to +/-10 Vdc.

The output signal range can be selected between 0 to +10 Vdc or -10 to +10 Vdc, or 4 to 20 mA using parameter H4-07 and H4-08. *Figure 4.44* illustrates how gain and bias settings work.

No.	Name	Setting Range	Default
H4-02	Multi-Function Analog Output Terminal FM Gain	-999.9 to 999.9%	100.0%
H4-03	Multi-Function Analog Output Terminal FM Bias	-999.9 to 999.9%	0.0%
H4-05	Multi-Function Analog Output Terminal AM Gain	-999.9 to 999.9%	50.0%
H4-06	Multi-Function Analog Output Terminal AM Bias	-999.9 to 999.9%	0.0%

### Using Gain and Bias to Adjust Output Signal Level

The output signal is adjustable while the drive is stopped.

#### Terminal FM

1. View the value set to H4-02 (Terminal FM Monitor Gain) on the digital operator. A voltage equal to 100% of the parameter being set in H4-01 will be output from terminal FM.
2. Adjust H4-02 viewing the monitor connected to the terminal FM.
3. View the value set to H4-03 on the digital operator; terminal FM will output a voltage equal to 0% of the parameter being set in H4-01.
4. Adjust H4-03 viewing the output signal on the terminal FM.

#### Terminal AM

1. View the value set to H4-05 (Terminal AM Monitor Gain) on the digital operator. A voltage equal to 100% of the parameter being set in H4-04 will be output from terminal AM.
2. Adjust H4-05 viewing the monitor connected to the terminal AM.
3. View the value set to H4-06 on the digital operator; terminal AM will output a voltage equal to 0% of the parameter being set in H4-04.
4. Adjust H4-06 viewing the output signal on the terminal AM.

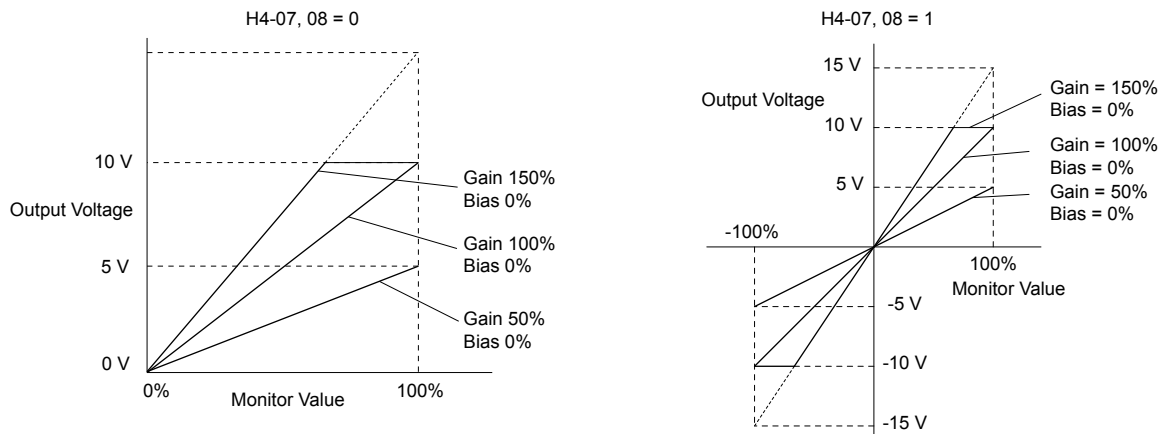

**Figure 4.44 Analog Output Gain and Bias Setting Example 1 and 2**

Set H4-03 to 30% for an output signal of 3 V at terminal FM when the monitored value is at 0%.

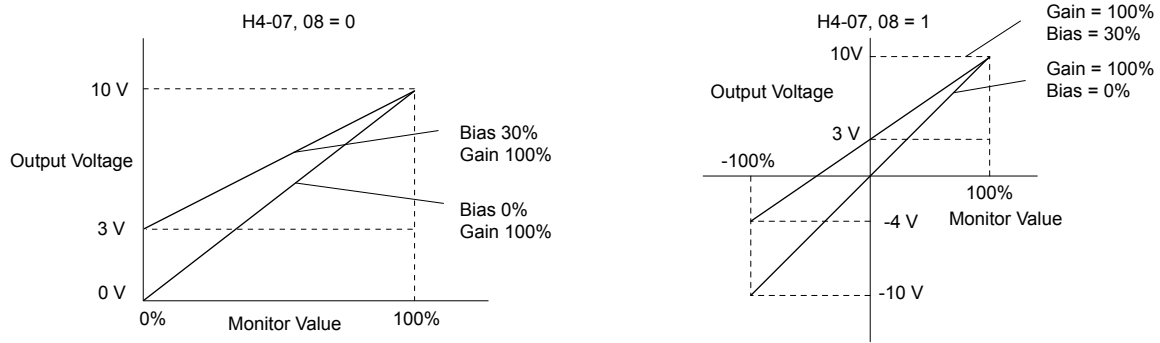

Figure 4.45 Analog Output Gain and Bias Setting Example 3

■ **H4-07, H4-08: Multi-Function Analog Output Terminal FM, AM Signal Level Selection**

Sets the voltage output level of U parameter (monitor parameter) data to terminal FM and terminal AM using parameters H4-07 and H4-08.

Set jumper S5 on the terminal board accordingly when changing these parameters. *Refer to Terminal AM/FM Signal Selection on page 129* for details on setting S5.

No.	Name	Setting Range	Default
H4-07	Multi-Function Analog Output Terminal FM Signal Level Selection	0 to 2	0
H4-08	Multi-Function Analog Output Terminal AM Signal Level Selection	0 to 2	0

**Setting 0: 0 to 10 V**

**Setting 1: -10 V to 10 V**

**Setting 2: 4 to 20 mA**

■ **L5-01: Number of Auto Restart Attempts**

Sets the number of times that the drive may attempt to restart itself.

When the counter reaches the number set to L5-01, the operation stops and the fault must be manually cleared and reset.

The restart counter is incremented at each restart attempt, regardless of whether the attempt was successful. When the counter reaches the number set to L5-01, the operation stops and the fault must be manually cleared and reset.

The number of fault restarts is reset to zero when:

- The drive operates normally for 10 minutes following a fault restart.
- A fault is cleared manually after protective functions are triggered.
- The power supply is cycled.

No.	Name	Setting Range	Default
L5-01	Number of Auto Restart Attempts	0 to 10 Times	5 Times

■ **L5-04: Fault Reset Interval Time**

Determines the amount of time to wait between restart attempts when parameter L5-05 is set to 1.

No.	Name	Setting Range	Default
L5-04	Fault Reset Interval Time	0.5 to 600.0 s	10.0 s

■ **o1-08: Third Line User Monitor Selection**

Selects the monitor that is shown in the third line. Effective only when o1-06 is set to 1.

Enter the last three digits of the monitor parameter number to be displayed: U□-□□. For example, set “403” to display monitor parameter U4-03.

No.	Name	Setting Range	Default
o1-08	Second Line User Monitor Selection	101 to 799	103

## 4.7 Basic iQpump Setup and Application Preset Parameters

### ■ P1-01: Pump Mode

Selects the base operation mode of the drive controller.

No.	Parameter Name	Setting Range	Default
P1-01	Pump Mode	0, 1, 3	0

#### Setting 0: Drive only

Designed for single pump stand-alone applications

#### Setting 1: Contactor lag

Contactor Lag systems multiplex a main pump with up to 5 lag pumps. The drive will stage and de-stage the lag pumps based on system demand by using its digital output contacts to control the lag pump motor starters

#### Setting 3: MEMOBUS network

Up to eight drives can be networked together to provide for system redundancy and precise control.

When P6-01 > 0, the Flow Rate can come from another drive on the MEMOBUS Network.

Setting P9-40 to 0 (Analog) will read the Flow Meter from the analog terminal (H3-□□ = 22) or from the pulse input (H6-01 = 5), while setting P9-40 to 3 (Network) will read the Flow Meter information from the network. When there is no such drive on the network, a “Net Flow Meter Lost, Chk Source” alarm is triggered for drives with P9-40 set to 3 (Network) and P6-01 > 0.

Staging is disabled when and the drive PI output is influenced by the Water Level / Suction Pressure Control.

The functions listed below will behave slightly different when P1-01 is set to 3:

- **Start Level:** Active on the first pump in the network. Drives in the process of alternation will not undergo this process.
- **Sleep:** Active when the drive is the only drive running on the network.
- **Over-cycle Protection:** Active when the drive is the only drive running on the network.
- **Pre-charge:** Active only on the first drive to run in the network.
- **Low City Pressure:** Active on any drive in the network. An alarm condition will cause other drives in the network to stop running and show a “Net Pump Err” message.
- **Utility Delay:** When this function is active, the drive is unavailable to the iQpump MEMOBUS Network and will force the Home Screen text to show “Pump Off Network”.
- **Remote Drive Disable:** When this function is active, the drive is unavailable to the iQpump MEMOBUS Network and will force the Home Screen text to show “Pump Off Network”.

### ■ P1-02: System Units

Selects the base unit in which most drive PID setpoints, scaling, monitors, limits, and faults/alarm levels will be set.

**Note:** Set this parameter prior to changing other parameters, as internal scaling is based on P1-02.

No.	Parameter Name	Setting Range	Default
P1-02	System Units	0 to 10; 25, 26	1

#### Setting 0: No unit

#### Setting 1: PSI: Pounds per square inch

#### Setting 2: Pa: Pascals

#### Setting 3: Bar: Bar

#### Setting 4: "WC: Inch of water

#### Setting 5: "Hg: Inch of Mercury

#### Setting 6: ft: feet

#### Setting 7: m: meters

#### Setting 8: °F: Degrees Fahrenheit

#### Setting 9: °C: Degrees Celsius

#### Setting 10: Percent

#### Setting 25: Flow (Use P6-04)

**Note:** When using setting 25, the system units are set by parameter P6-04 and the PID feedback is re-routed to come from the flow meter, pulse input (H6-01 = 5), or analog (H3-0□ = 22).

**Setting 26: Custom (P1-32 to P1-34)**

This setting allows the user to create a custom system unit display with up to three characters. Use parameters P1-32 to P1-34 to make the custom system unit.

The following are the selections available for custom system units:

Setting	Character	Setting	Character	Setting	Character	Setting	Character
20	SPACE	34	4	4F	O	69	I
21	!	35	5	50	P	6A	j
22	“	36	6	51	Q	6B	k
23	#	37	7	52	R	6C	l
24	\$	38	8	53	S	6D	m
25	%	39	9	54	T	6E	n
26	&	41	A	55	U	6F	o
27	'	42	B	56	V	70	p
28	(	43	C	57	W	71	q
29	)	44	D	58	X	72	r
2A	*	45	E	59	Y	73	s
2B	+	46	F	5A	Z	74	t
2C	,	47	G	61	a	75	u
2D	-	48	H	62	b	76	v
2E	.	49	I	63	c	77	w
2F	/	4A	J	64	d	78	x
30	0	4B	K	68	e	79	y
31	1	4C	L	66	f	7A	z
32	2	4D	M	67	g		
33	3	4E	N	68	h		

**■ P1-03: Feedback Device Scaling**

Sets the feedback device scaling used for the PID controller. This information can be found on the nameplate or specification sheet and is usually expressed as the maximum output of the device.

For example, a pressure sensor scaling might be 145.0 PSI at 20 mA output and would require setting P1-03 to 145.0 PSI.

**Note:** Set this parameter prior to changing other parameters related to the PID feedback, as internal scaling is based on P1-03.

No.	Parameter Name	Setting Range	Default
P1-03	Feedback Device Scaling	0.1 to 6000.0	145.0 PSI

**■ P1-04: Start / Draw Down Level**

Sets the wake up level from the Sleep function. This setting is dependent on whether PID is normal or inverse acting (b5-09). When the drive is asleep and the PID feedback signal rises above (normal acting) or falls below (inverse acting) this setting for the time set in P1-05, Start Level Delay Time, the drive will wake up.

This parameter activates the sleep function when the pump reaches the minimum pump speed set in P1-06 for the time set in P2-03.

No.	Parameter Name	Setting Range	Default
P1-04	Start / Draw Down Level	</>	0.0 PSI

<1> Range is 0.0 to 999.9 with sign-bit “-” or “+” indicating Delta to Setpoint.  
Range is -999.9 to 999.9 in drive software versions PRG: 8551 and earlier.

**■ P1-05: Start Level Delay Time**

Sets the delay time for waking the drive to prevent accidental wake up caused by erratic feedback.

No.	Parameter Name	Setting Range	Default
P1-05	Start Level Delay Time	0 to 3600 s	1 s

## 4.7 Basic iQpump Setup and Application Preset Parameters

### ■ P1-06: Minimum Pump Speed

Sets the minimum speed at which the drive will run the pump. Most pumps cannot run at low speeds due to cavitation, so be sure to consult the pump specification sheet for the minimum safe run speed.

No.	Parameter Name	Setting Range	Default
P1-06	Minimum Pump Speed	0.0 to E1-04	40.0 Hz

### ■ P1-08: Low Feedback Level

Sets the level at which a Low Feedback alarm or fault will occur. When the PID feedback falls below the P1-08 setting for the time set in P1-09, the drive will respond based on the setting in P1-10.

No.	Parameter Name	Setting Range	Default
P1-08	Low Feedback Level	<1>	0.0 PSI

<1> Range is 0.0 to 999.9 with sign-bit “-” indicating Delta to Setpoint.  
Range is 0.0 to 6000.0 in drive software versions PRG: 8551 and earlier.

### ■ P1-09: Low Feedback Level Fault Delay Time

Sets the delay time after which a Low Feedback alarm or fault will occur. When the PID feedback falls below the P1-08 setting for the time set in P1-09, the drive will respond based on the setting in P1-10.

No.	Parameter Name	Setting Range	Default
P1-09	Low Feedback Level Fault Delay Time	0 to 3600 s	10 s

### ■ P1-10: Low Feedback Selection

Selects the drive response to a Low Feedback condition. When the PID feedback falls below the P1-08 setting for the time set in P1-09, the drive will respond based on the setting in P1-10.

No.	Parameter Name	Setting Range	Default
P1-10	Low Feedback Selection	0 to 2	0

Low feedback detection is enabled when:

- P1-08 > 0.0
- Drive is running in AUTO Mode, including sleep boost and feedback drop detection (standard PID, b5-09 = 0)
- Run Command is present (including sleep and timer operation) (inverse PID, b5-09 = 1)

#### Setting 0: Fault

When feedback drops below the P1-08 level for longer than the time set in P1-09, the drive will fault on the “LFB – Low Feedback” fault and coast to a stop.

The digital output programmed to “Low Feedback” (H2-0□ = 97) closes. The drive will also display the “Low Feedback – Low FB Sensed” alarm. The digital output will remain closed until the fault is reset.

#### Setting 1: Alarm

When feedback drops below the P1-08 level for longer than the time set in P1-09, the digital output programmed to “Low Feedback” (H2-0□ = 97) closes and the drive displays the “Low Feedback – Low FB Sensed” alarm.

When feedback rises above the level determined by P1-08 and P1-14, or when one or more of the conditions that enable low feedback detection are no longer true, the digital output will open and the alarm will clear.

#### Setting 2: Digital out only

When feedback drops below the P1-08 level for longer than the time set in P1-09, the digital output programmed to “Low Feedback” (H2-0□ = 97) closes.

When feedback rises above the level determined by P1-08 and P1-14, or when one or more of the conditions that enable low feedback detection are no longer true, the digital output will open.

### ■ P1-11: High Feedback Level

Sets the level at which a High Feedback alarm or fault will occur. When the PID feedback rises above the P1-11 setting for the time set in P1-12, the drive will respond based on the setting in P1-13.



No.	Parameter Name	Setting Range	Default
P1-11	High Feedback Level	</>	155.0 PSI

<1> Range is 0.0 to 999.9 with sign-bit “+” indicating Delta to Setpoint.  
Range is 0.0 to 6000.0 in drive software versions PRG: 8551 and earlier.

### ■ P1-12: High Feedback Level Fault Delay Time

Sets the delay time after which a Low Feedback alarm or fault will occur. When the PID feedback rises above the P1-11 setting for the time set in P1-12, the drive will respond based on the setting in P1-13.

No.	Parameter Name	Setting Range	Default
P1-12	High Feedback Level Fault Delay Time	0 to 3600 s	5 s

### ■ P1-13: High Feedback Selection

Selects the drive response to a High Feedback condition. When the PID feedback rises above the P1-11 setting for the time set in P1-12, the drive will respond based on the setting in P1-13.

No.	Parameter Name	Setting Range	Default
P1-13	High Feedback Selection	0 to 2	0

High feedback detection is enabled when:

- P1-11 > 0
- Run Command present, including sleep & timer operation (standard PID, b5-09 = 0)
- Drive is running in AUTO Mode, including feedback drop detection (inverse PID, b5-09 = 1).

#### Setting 0: Fault

When feedback rises above the P1-11 for longer than the time set in P1-12, the drive will fault on the “HFB – High Feedback” fault and coast to a stop.

The digital output programmed to “High Feedback” (H2-0□= 96) closes. The drive will also display the “High Feedback – High FB Sensed” alarm. The digital output will remain closed until the fault is reset.

#### Setting 1: Alarm

When feedback rises above the P1-11 for longer than the time set in P1-12, the digital output programmed to “High Feedback” (H2-0□= 96) closes and the drive displays the “High Feedback – High FB Sensed” alarm.

When feedback falls below the level determined by P1-11 and P1-14, or when one or more of the conditions that enable high feedback detection are no longer true, the digital output will open and the alarm will clear.

#### Setting 2: Digital out only

When feedback rises above the P1-11 for longer than the time set in P1-12, the digital output programmed to “High Feedback” (H2-0□= 96) closes.

When feedback falls below the level determined by P1-11 and P1-14, or when one or more of the conditions that enable high feedback detection are no longer true, the digital output will open.

### ■ P1-40: Maximum Pump Speed

Sets the maximum pump speed determined by the smallest value among P1-40, E1-04, and d2-01. This parameter is not effective when set to 0 or when set higher than E1-04 x d2-01.

When this parameter ≠ 0, maximum pump speed is internally lower limited to the minimum pump speed (largest setting among P1-06, P4-12, and d2-02).

- Note:**
1. Parameter available in drive software versions PRG: 8552 and later.
  2. Parameter not available in drive models 4A0930 and 4A1200.

No.	Parameter Name	Setting Range	Default
P1-40	Maximum Pump Speed	0.0 to 440.0 Hz	0.0 Hz

### ■ P2-01: Sleep Level Type

Selects which data source the drive will use to determine if it should activate the sleep function. This parameter is application-dependent and should be set in conjunction with the type of system data is available. Choose the data type that best represents a low-activity condition for the system.

- Note:** Set this parameter prior to changing other parameters related to the Sleep Function, as internal scaling is based on P2-01.

## 4.7 Basic iQpump Setup and Application Preset Parameters

No.	Parameter Name	Setting Range	Default
P2-01	Sleep Level Type	0 to 4	0

**Setting 0: Output frequency**

**Setting 1: Output current**

**Setting 2: Feedback**

**Setting 3: Output speed (RPM)**

**Setting 4: Flow meter (requires flow meter)**

### ■ P2-02: Sleep Level

Sets the level at which the drive will enter sleep mode. The drive will enter sleep mode when the monitored data falls below the P2-02 setting for the time set in P2-03.

No.	Parameter Name	Setting Range	Default
P2-02	Sleep Level	0.0 to 6000.0	0.0 Hz

### ■ P2-03: Sleep Delay Time

Sets the delay time after which the drive will enter sleep mode. The drive will enter sleep mode when the monitored data falls below the P2-02 setting for the time set in P2-03.

No.	Parameter Name	Setting Range	Default
P2-03	Sleep Delay Time	0 to 3600 s	5 s

### ■ P2-15: Sleep AUTO → OFF

When enabled, Sleep is active even if the Start Level P1-04 is set to 0. In addition, the drive will switch to OFF mode when called to Sleep.

- Note:**
1. Parameter available in drive software versions PRG: 8552 and later.
  2. Parameter not available in drive models 4A0930 and 4A1200.

No.	Parameter Name	Setting Range	Default
P2-15	Sleep AUTO → OFF	0, 1	0

#### Setting 0: Disabled

Set P1-04 ≠ 0 to enable Sleep operation with this setting. When drive goes to sleep, output speed falls to 0 and the drive stays in Auto Mode.

#### Setting 1: Enabled

Sleep operation is enabled regardless of P1-04 value for this setting. When the drive calls for Sleep, the mode switches from AUTO to OFF and the drive displays the Sleep AUTO->Off message.

Press any key, run the drive in AUTO, HAND, or JOG to dismiss the message. Issue the AUTO command to run the drive again.

### ■ P3-00: Number of Lag Pumps

Sets the number of lag pumps in the system. When using Contactor Multiplexing for the control lag pumps, first set P1-01 to 1. Then select the number of lag pumps to be controlled in P3-00. Set the corresponding multi-function digital outputs for lag pumps (H2-□□ = 80-82 and F5-□□ = 83-84). The methods used to determine lag pump staging and de-staging order are selected in P1-30 and P1-31.

No.	Parameter Name	Setting Range	Default
P3-00	Number of Lag Pumps	1 to 5	1

### ■ P3-50: Pump 2 Frequency Shutdown Level

Sets the level at which the first lag pump (2nd pump in the system) will shut down or de-stage. This parameter is effective when the P3-01 is set to 0 or 2 (pump staging is based on output frequency). When the output frequency falls below the P3-50 level for the time set in P3-09, the pump will be de-staged.

No.	Parameter Name	Setting Range	Default
P3-50	Pump 2 Frequency Shutdown Level	0.0 to 400.0	40.0 Hz

**■ P3-60: Pump 3 Frequency Shutdown Level**

Sets the level at which the second lag pump (3rd pump in the system) will shut down or de-stage. This parameter is effective when the P3-01 is set to 0 or 2 (pump staging is based on output frequency). When the output frequency falls below the P3-50 level for the time set in P3-09, the pump will be de-staged.

No.	Parameter Name	Setting Range	Default
P3-60	Pump 3 Frequency Shutdown Level	0.0 to 400.0	40.0 Hz

**■ P3-70: Pump 4 Frequency Shutdown Level**

Sets the level at which the third lag pump (4th pump in the system) will shut down or de-stage. This parameter is effective when the P3-01 is set to 0 or 2 (pump staging is based on output frequency). When the output frequency falls below the P3-50 level for the time set in P3-09, the pump will be de-staged.

No.	Parameter Name	Setting Range	Default
P3-70	Pump 4 Frequency Shutdown Level	0.0 to 400.0	40.0 Hz

**■ P4-01: Pre-Charge Level**

Sets the level at which the drive will activate the pre-charge function. At start, if the PID is below the P4-01 setting, the drive will run at the P4-02 frequency setting for the time set in P4-03. PID control is delayed until the Pre-charge function stops. The drive will exit the pre-charge function early if the feedback rises above the P4-01 setting or if a Low Water digital input switch (H1-□□ = 8F) deactivates. Pre-charge is useful to slowly fill or pressurize a system.

No.	Parameter Name	Setting Range	Default
P4-01	Pre-Charge Level	0.0 to 6000.0	0.0 PSI

**■ P4-02: Pre-Charge Frequency**

Sets the frequency at which the pre-charge function will run.

No.	Parameter Name	Setting Range	Default
P4-02	Pre-Charge Frequency	0.0 to E1-04	0.0 Hz

**■ P4-03: Pre-Charge Time**

Sets the duration of time that the pre-charge function will run.

No.	Parameter Name	Setting Range	Default
P4-03	Pre-Charge Time	0.0 to 3600.0 min	0.0 min

The following conditions must be met to enter Pre-Charge Mode:

- Drive Ready or Sleeping (Run command, not faulted, not in program mode)
- NOT in HAND Mode
- “Disable Pre-Charge” digital input NOT closed
- P4-03 > 0.0
- If P4-01, Pre-Charge Level, is greater than 0, the PID feedback must be below the P4-01 level. (Forward acting PID, b5-09 = 0, Reverse acting PID, b5-09 = 1).

When the drive enters Pre-Charge Mode 1 and 2, the drive runs at the Pre-Charge frequency set in P4-02/P4-06, the PID controller is disabled and the Pre-Charge digital output (H2-0□ = A4) closes.

When pre-charge is active, the message “Pre Chg Mode Exit in Xsec” appears on the keypad to show how long before pre-charge exits via timers (P4-03 + P4-07).

Additionally, during Pre-Charge Mode:

- When Pre-Charge Level 2 (P4-32) is set to 0, the system can exit Pre-Charge when the PID Feedback goes above the Pre-Charge Level (P4-01) in normal PID operation, or below the P4-01 level in inverse PID operation.

However, when Pre-Charge Level 2 (P4-32) is set to a non-zero value, the system goes into Pre-Charge 2 instead when Pre-Charge 1 completes via timer (P4-03) or level (P4-01). At this point, the drive will run at Pre-Charge Frequency 2 (P4-06).

The system can exit Pre-Charge 2 when the PID Feedback goes above the Pre-Charge Level 2 (P4-32) in normal PID operation, or below the P4-32 level in inverse operation. Refer to [Figure 4.46](#) and [Figure 4.47](#) for more information.

## 4.7 Basic iQpump Setup and Application Preset Parameters

- When P4-02, Pre-Charge Frequency, or P4-06, Pre-Charge Frequency 2, are set to a value less than P1-06, Minimum Pump Speed, the alarm “Freq. Ref < Pump Min P1-06” is displayed and the drive runs at the minimum speed.
- When Pre-Charge Loss of Prime parameters P4-05 and P4-08 are set to 0, the Loss of Prime detection is disabled.
- When Pre-Charge Loss of Prime parameters P4-05 or P4-08 are set to a value greater than 0, Loss of Prime detection will operate after the output speed reaches the Pre-Charge Frequency set in P4-02 or P4-06.
- The “Low Water” fault (H1-0□ = 8F) is disabled.
- The “Low Feedback” fault is disabled when forward-acting PID is selected (b5-09 = 0) and the “High Feedback” fault is disabled when reverse-acting PID is selected (b5-09 = 1).
- The “Not Maintaining Setpoint” fault is disabled.
- The “Feedback Loss” detection (4 to 20 mA wire break) is enabled, however, the Pre-Charge frequencies will override and the b5-13 “feedback loss goto speed”.

The drive will always exit Pre-Charge Mode when Pre-Charge times P4-03 and P4-07 have expired. The drive will also exit Pre-Charge Mode when one of the following conditions are met:

- P4-03 and P4-32 are set to 0.0
- The “Disable Pre-Charge” digital input (H1-0□ = 8C) closes.
- A digital input programmed to “Low Water” (H1-0□ = 8F) is deactivated (open when P1-30 = 0 or closed when P1-30 = 1).
- The PID feedback satisfies both Pre-Charge levels 1 and 2 (all must be true):

Pre-Charge timers P4-03 and P4-07 have NOT expired

PID is enabled (b5-01 > 0).

PID is NOT disabled via digital input

Pre-Charge Level Set (P4-01 > 0) (and if used, P4-32 > 0)

Feedback is greater than Pre-Charge Level (P4-01) and Pre-Charge Level 2 (P4-32) (forward-acting PID, b5-09 = 0) or less than Pre-Charge Levels 1 and 2 (reverse-acting PID, b5-09 = 1)

Drive is NOT in a “Feedback Loss” condition (4 to 20 mA wire-break detection).

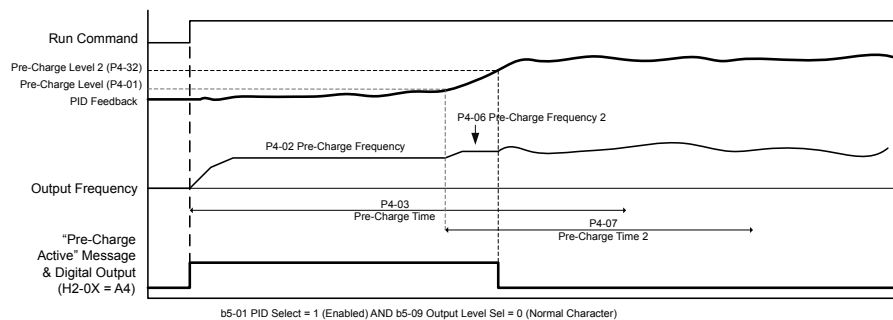

**Figure 4.46 Pre-Charge 1 and 2 Complete via PID Feedback**

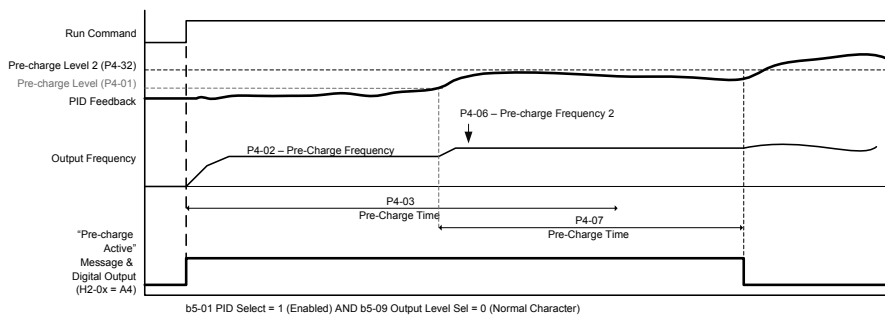

**Figure 4.47 Pre-Charge 1 Complete via PID Feedback & Pre-Charge 2 via Timer**

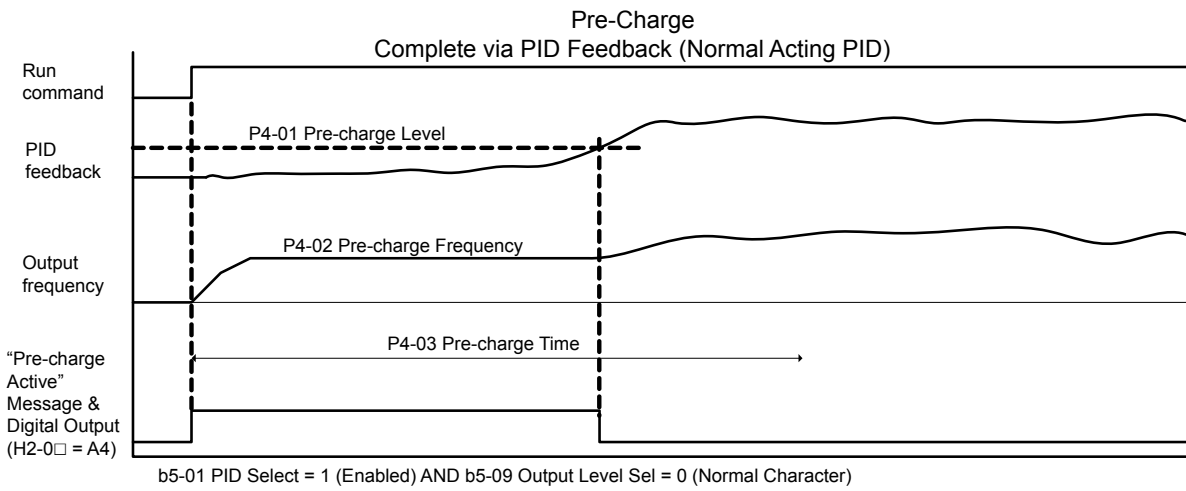

Figure 4.48 Pre-Charge Normal Acting PID

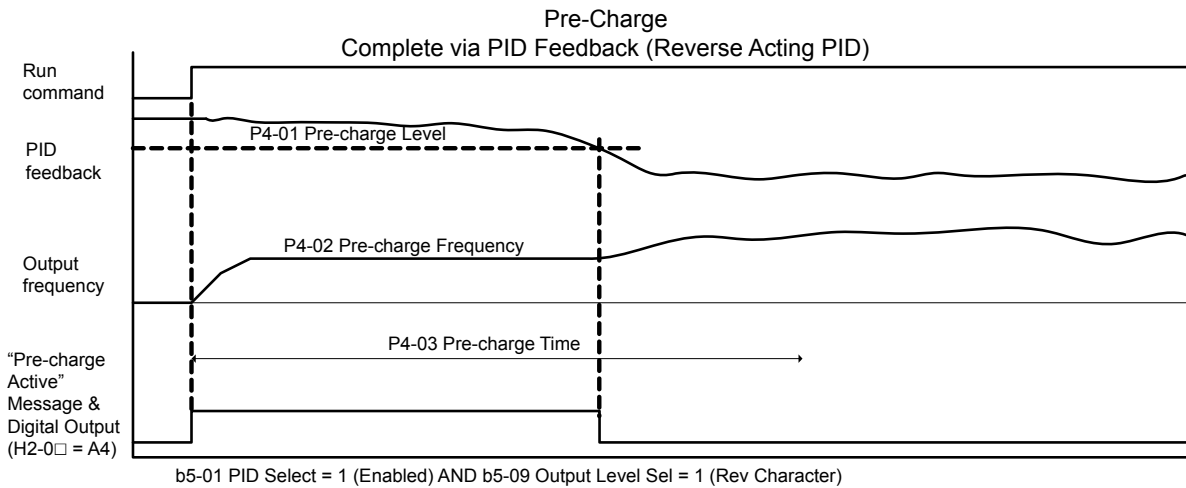

Figure 4.49 Pre-Charge Inverse Acting PID

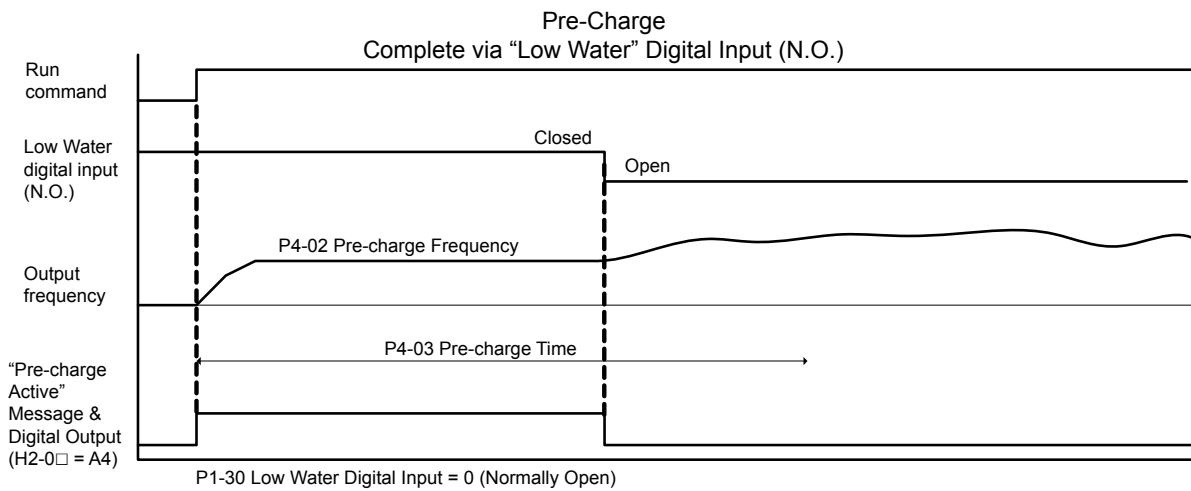

Figure 4.50 Pre-Charge via Low Water DI

## 4.7 Basic iQpump Setup and Application Preset Parameters

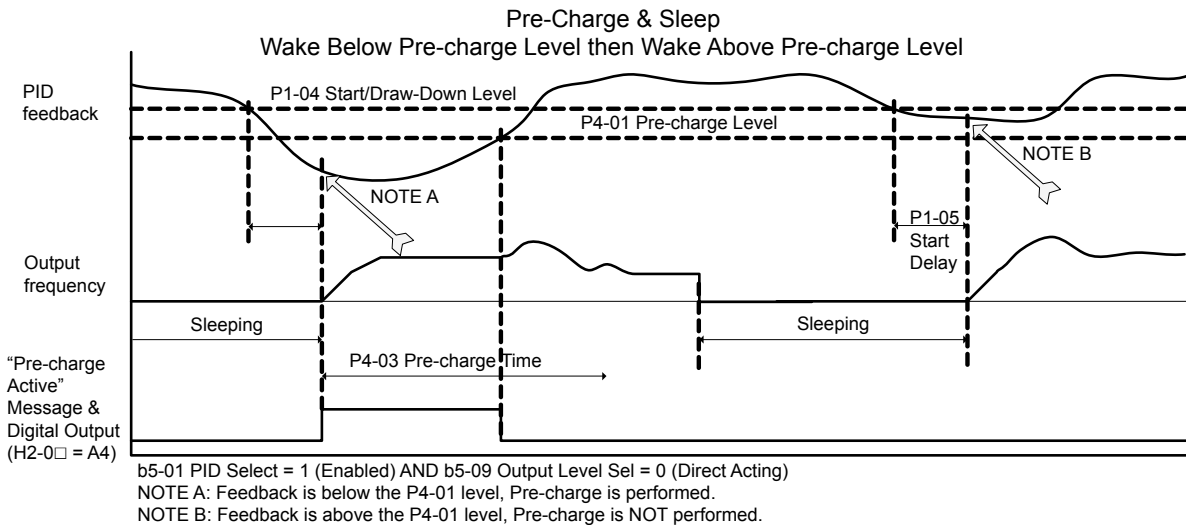

Figure 4.51 Pre-Charge and Sleep

### ■ P4-04: Pre-Charge Message Style

Selects how the “Pre-charge Active” message is displayed on the operator.

No.	Parameter Name	Setting Range	Default
P4-04	Pre-Charge Message Style	0, 1	0

#### Setting 0: Full Screen Message

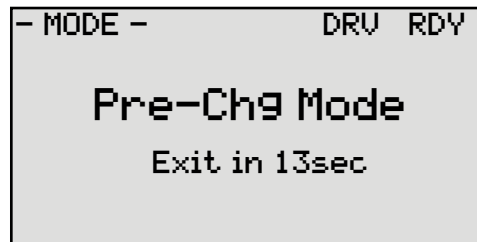

#### Setting 1: Home Monitor Text

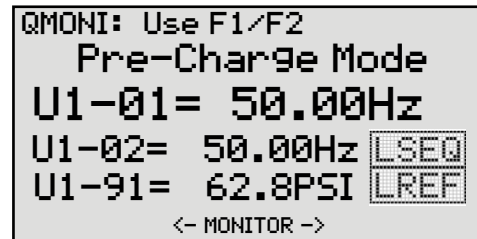

### ■ P4-10: AUTO Mode Operator Run Power Down Storage

Selects drive response to power loss with regards to the Run command. When running in AUTO Mode and using a Run command from the keypad (b1-02 = 0), P4-10 determines whether the drive will automatically start running when power is reapplied. The factory setting of this parameter requires pressing the AUTO key to start the drive after power loss.

**WARNING! Sudden Movement Hazard.** If the drive is running at power loss, it will automatically initiate an internal Run command upon power-up if P4-10 = 1 (Enabled) and could result in death or serious injury from moving equipment.

No.	Parameter Name	Setting Range	Default
P4-10	AUTO Mode Operator Run Power Down Storage	0, 1	0

Setting 0: Disabled

Setting 1: Enabled

■ P4-12: Thrust Bearing Frequency

Sets the frequency used by the drive when determining which acceleration and deceleration time to use. The Thrust Bearing function is used for applications using submersible motors. The function provides an alternate acceleration time (P4-11) and deceleration time (P4-13) for protecting the pump bearings.

At start, the drive will use the P4-11 acceleration time until the P4-12 frequency is reached, at which time it will use the active C1-□□ acceleration and deceleration times. At stop, if the output frequency is above the P4-12 setting, the active C1-□□ deceleration time will be used until the P4-12 setting is reached at which time it will use the P4-13 time setting for the rest of deceleration.

If P4-12 is set greater than P1-06 (minimum Pump Speed), P4-12 will become the frequency lower limit. The drive PID control must be disabled (b5-01 = 0) for this function to work.

No.	Parameter Name	Setting Range	Default
P4-12	Thrust Bearing Frequency	0.0 to E1-04	30.0 Hz

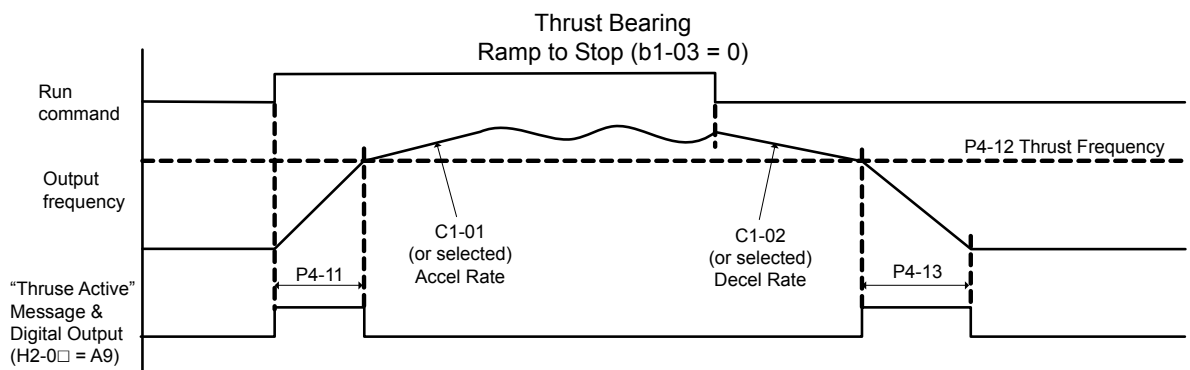

Figure 4.52 Thrust Bearing

■ P4-17: Utility Start Delay

Sets the delay time after power up until the drive will recognize a Run command present within one second of power up or when the Run command is jumpered on the terminal strip.

This is useful in preventing a peak power surge when multiple drives power up and begin accelerating simultaneously. This function works when the drives all have different P4-17 settings to spread out the power draw during acceleration.

If the Run command is removed and re-applied during the P4-17 time, the drive will cancel the utility start delay and immediately begin running.

The Utility Start Delay is applied when the drive is auto-restarting after an Undervoltage (Uv) or an Overvoltage (ov) condition.

No.	Parameter Name	Setting Range	Default
P4-17	Utility Start Delay	0.0 to 1000.0 min	0.2 min

■ P4-40: Pressure Reached Detection Selection

Sets the drive state that must be met when triggering the Pressure Detection digital output.

No.	Parameter Name	Setting Range	Default
P4-40	Pressure Reached Detection Selection	0 to 2	0

Setting 0: Always

Triggers the digital output regardless of drive status (even when the drive is stopped or sleeping).

Setting 1: Drive Running

Triggers the digital output if the drive is producing output voltage (not baseblocked) to the motor. The digital output will not engage when the drive is sleeping.

## 4.7 Basic iQpump Setup and Application Preset Parameters

### Setting 2: Run Command

Triggers the digital output when there is an active Run command.

#### ■ P5-02: HAND Reference 1

Sets the frequency reference of HAND mode. When the drive is stopped, pressing the HAND key will start the drive and the drive will accelerate to the P5-02 setting.

No.	Parameter Name	Setting Range	Default
P5-02	HAND Reference 1	0.0 to E1-04	40.0 Hz

#### ■ P5-04: HAND Key Function Selection

Selects whether the HAND key on the HOA keypad is active. Disabling this function by setting P5-04 to 0 will prevent the drive from entering HAND Mode.

No.	Parameter Name	Setting Range	Default
P5-04	HAND Key Function Selection	0, 1	1

Setting 0: Disabled

Setting 1: Enabled

#### ■ P6-12: Accumulation Level - Thousands

Sets the accumulated volume that will trigger the Accum Level alarm, Accum Level fault, or the Accum Level Fault – Auto Flow Accum Reset.

No.	Name	Setting Range	Default
P6-12	Accumulation Level - Thousands	0 to 999	0 gal

#### ■ P6-15: Accumulation Behavior

Selects the drive response when the accumulated volume reaches the level set in parameters P6-11 to P6-14.

No.	Name	Setting Range	Default
P6-15	Accumulation Behavior	0 to 5	1

Setting 0: No display

Setting 1: Alarm only

Setting 2: Fault

Setting 3: Fault - Auto flow accum reset

Setting 4: Stop and alarm

Setting 5: Stop, alarm, and reset flow accumulation

#### ■ P6-17: High Flow Level

Sets the level above which the flow must rise for longer than the time set in P6-18 to trigger a High Flow fault or alarm.

A setting of 0.0 disables High Flow detection.

No.	Name	Setting Range	Default
P6-17	High Flow Level	0.0 to 6000.0	0.0 GPM

#### ■ P6-19: High Flow Select

Determines drive response when a High Flow condition is detected.

No.	Name	Setting Range	Default
P6-19	High Flow Select	0 to 3	1



Setting 0: No display

Setting 1: Alarm only

Setting 2: Fault

Setting 3: Auto-restart (time set by L5-04)

■ **P6-25: Flow Rate Limit Foldback Message Style**

Selects how the “Flow Rate Limit Foldback” message is displayed on the operator.

No.	Parameter Name	Setting Range	Default
P6-25	Flow Rate Limit Foldback Message Style	0, 1	0

Setting 0: Full Screen Message

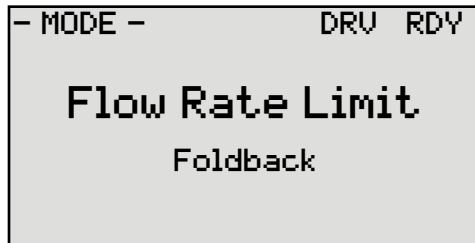

Setting 1: Home Monitor Text

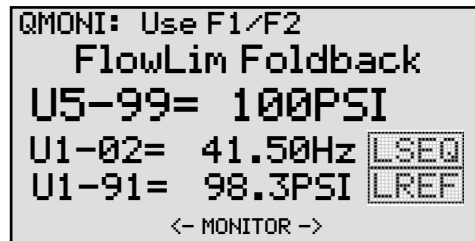

■ **Q1-01: PID Controller Setpoint 1**

Sets the PID setpoint for the controller. The drive will use the system feedback signal and modulate the pump speed to regulate the feedback at the Q1-01 setpoint. The units for Q1-01 are selected by b1-01 and the scaling is set in parameter P1-03. This parameter is active when b1-01 (Reference Source) is set to 0 (HOA keypad).

No.	Parameter Name	Setting Range	Default
Q1-01	PID Controller Setpoint 1	0.0 to 6000.0	0.0 PSI

■ **Q3-06: Current Limit Foldback Message Style**

Selects how the “Current Limit Foldback” message is displayed on the operator.

No.	Parameter Name	Setting Range	Default
Q3-06	Current Limit Foldback Message Style	0, 1	0

Setting 0: Full Screen Message

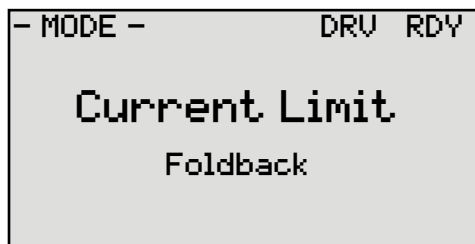

## 4.7 Basic iQpump Setup and Application Preset Parameters

### Setting 1: Home Monitor Text

```

QMONI: Use F1/F2
      Cur Lim Foldback
U5-99= 100PSI
U1-02= 41.50Hz [LSEQ]
U1-91= 98.3PSI [LREF]
      <- MONITOR ->
    
```

### ■ Q3-13: Single Phase Foldback Message Style

Selects how the “Single Phase Foldback” message is displayed on the operator.

No.	Parameter Name	Setting Range	Default
Q3-13	Single Phase Foldback Message Style	0, 1	0

### Setting 0: Full Screen Message

```

- MODE -          DRU RDY

      Single Phase
      Foldback
    
```

### Setting 1: Home Monitor Text

```

QMONI: Use F1/F2
      1-Phase Foldback
U5-99= 100PSI
U1-02= 41.50Hz [LSEQ]
U1-91= 98.3PSI [LREF]
      <- MONITOR ->
    
```

### ■ Q5-03: Suction Pressure Setpoint

Sets the Suction Pressure setpoint. The units of Q5-03 are selected in Q5-01 and the scaling is set in Q5-02 (Suction Transducer Scaling). The Suction Pressure function is enabled by setting Q5-01 = 1 (Suction Pressure). This function uses Q5-03 as the setpoint instead of Q1-01, and Q5-02 as the feedback scaling instead of P1-02. Set b5-01 to a value other than 0 to enable the drive PID controller and use this function.

This feature can be used to allow the drive to control (outlet) pressure when there is adequate pressure on the inlet side of the pump by setting Q5-01 to 1 (Suction Pressure). When the suction pressure (pump inlet pressure) drops to the Suction Pressure Setpoint (Q5-03), it will regulate the suction pressure and the outlet pressure will be allowed to drop. This requires both a suction pressure transducer on the pump inlet and a pressure feedback transducer on the pump output.

No.	Parameter Name	Setting Range	Default
Q5-03	Suction Pressure Setpoint	0.0 to 1200.0	20.0 PSI

### ■ Q5-06: Wake-Up Suction Pressure

Sets the wake up level for the suction pressure control function. The drive falls asleep based on the Q5-04 level and Q5-05 delay time. The drive will wake up when the suction pressure feedback rises above the Q5-06 setting for the time set in Q5-07 AND the standard sleep function calls for a wake up (P1-04 and P1-05).

No.	Parameter Name	Setting Range	Default
Q5-06	Wake-Up Suction Pressure	0.0 to 1200.0	30.0 PSI

### ■ Q5-09: Low Suction Pressure Detection Level

Sets the level at which a Low Suction Pressure alarm or fault will occur.

For Q5-01 = 1 (Suction Pressure): If Q5-11 = 2 or 3, the drive will respond based on the Q5-11 setting when the suction pressure feedback falls below the Q5-09 setting for the time set in Q5-10. If Q5-11 = 0 or 1, the drive will respond based on the Q5-11 setting as soon as the suction pressure feedback falls below the Q5-09 setting.

For Q5-01 = 2 (Vacuum): If Q5-11 = 1, 2 or 3, the drive will respond based on the Q5-11 setting when the suction pressure feedback falls below the Q5-09 setting for the time set in Q5-10. If Q5-11 = 0, the 9Ch Low Suction MFDO will close as soon as the suction pressure feedback falls below the Q5-09 setting.

No.	Parameter Name	Setting Range	Default
Q5-09	Low Suction Pressure Detection Level	0.0 to 1200.0	0.0 PSI

■ **Q5-10: Low Suction Pressure Detection Time**

Sets the delay time after which a Low Suction Pressure alarm or fault will occur. When the suction pressure feedback falls below the Q5-09 setting for the time set in Q5-10, the drive will respond based on the setting in Q5-11.

No.	Parameter Name	Setting Range	Default
Q5-10	Low Suction Pressure Detection Time	0.0 to 300.0	0.1 min

■ **Q5-11: Low Suction Pressure Behavior Select**

Selects the drive response to a Low Suction Pressure condition. When the suction pressure feedback falls below the Q5-09 setting for the time set in Q5-10, the drive will respond based on the setting in Q5-11. By setting Q5-11 to 3 (Restart Q5-15), the drive will attempt to reset itself for the number of times set in L5-01 waiting for the Q5-15 reset time before each reset attempt. The drive will fault if the L5-01 attempts are exceeded.

**Note:** If Q5-01 = 1 (Suction Pressure), the Q5-10 detection delay time only applies to Q5-11 settings 2 and 3. If Q5-01 = 2 (Vacuum), the Q5-10 detection delay time applies to Q5-11 settings 1, 2, and 3.

No.	Parameter Name	Setting Range	Default
Q5-11	Low Suction Pressure Behavior Select	0 to 3	1

**Setting 0: No display (digital output only)**

**Setting 1: Alarm only**

**Setting 2: Fault**

**Setting 3: Auto-restart (time set in Q5-15)**

■ **Q5-16: Suction Control Proportional Gain**

Sets the proportional gain of the Suction Pressure controller. Increasing this value will make the system more responsive but can lead to instability. Q5-16 is used in place of b5-02 for suction pressure control.

No.	Parameter Name	Setting Range	Default
Q5-16	Suction Control Proportional Gain	0.00 to 25.00	2.00

■ **Q5-17: Suction Control Integral Time**

Sets the integral time of the Suction Pressure controller. Decreasing this value will make the system more responsive but can lead to overshoot. Q5-17 is used in place of b5-03 for suction pressure control.

No.	Parameter Name	Setting Range	Default
Q5-17	Suction Control Integral Time	0.0 to 360.0 s	5.0 s

■ **Q6-23: PI Auxiliary Control**

Determines whether the PI Auxiliary Controller is Direct-acting (feedback higher than setpoint results in lower speed) or Inverse-acting (feedback lower than setpoint results in lower speed).

No.	Parameter Name	Setting Range	Default
Q6-23	PI Auxiliary Control	0, 1	1

**Setting 0: Direct Acting**

When Q6-25 (PI Aux Control Activation Level) = 0, the PI Aux Controller can affect the output frequency if the controller's output is less than the primary PID (System Pressure) controller's output.

## 4.7 Basic iQpump Setup and Application Preset Parameters

When Q6-25 (PI Aux Control Activation Level) > 0, the PI Aux Feedback Level (H3-□□ = 27) has to rise above the level set in Q6-25 for the time set in Q6-26 (PI Aux Control Activation Delay) before the PI Aux Controller is allowed to affect the output frequency.

When active, the PI Aux Feedback Level (H3-□□ = 27) has to drop below the Q6-25 level for the time set in Q6-26 before the PI Aux Controller is deactivated and not allowed to affect the output frequency.

### Setting 1: Inverse Acting

When Q6-25 (PI Aux Control Activation Level) = 0, the PI Aux Controller can affect the output frequency if the controller's output is less than the primary PID (System Pressure) controller's output.

When Q6-25 (PI Aux Control Activation Level) > 0, the PI Aux Feedback Level (H3-□□ = 27) has to drop below the level set in Q6-25 for the time set in Q6-26 (PI Aux Control Activation Delay) before the PI Aux Controller is allowed to affect the output frequency.

When active, the PI Aux Feedback Level (H3-□□ = 27) has to rise above the Q6-25 level for the time set in Q6-26 before the PI Aux Controller is deactivated and not allowed to affect the output frequency.

The following are the selections available for custom system units:

Setting	Character	Setting	Character	Setting	Character	Setting	Character
20	SPACE	34	4	4F	O	69	I
21	!	35	5	50	P	6A	j
22	“	36	6	51	Q	6B	k
23	#	37	7	52	R	6C	l
24	\$	38	8	53	S	6D	m
25	%	39	9	54	T	6E	n
26	&	41	A	55	U	6F	o
27	'	42	B	56	V	70	p
28	(	43	C	57	W	71	q
29	)	44	D	58	X	72	r
2A	*	45	E	59	Y	73	s
2B	+	46	F	5A	Z	74	t
2C	,	47	G	61	a	75	u
2D	-	48	H	62	b	76	v
2E	.	49	I	63	c	77	w
2F	/	4A	J	64	d	78	x
30	0	4B	K	68	e	79	y
31	1	4C	L	66	f	7A	z
32	2	4D	M	67	g		
33	3	4E	N	68	h		

### ■ S2-01/S2-06/S2-11/S2-16: Sequence Timers 1 to 4 Start Time

Sets the start times for timers 1 to 4.

If the Stop Time is set to a higher value than the Start Time, the Sequence Timers will be active starting from the set Start Time, run through midnight, and stop the following day at the set Stop Time.

**Note:** Setting the sequence timer start time to a higher value than the sequence timer stop time disables that sequence timer in drive software versions PRG: 8551 and earlier.

No.	Name	Setting Range	Default
S2-01	Sequence Timer 1 Start Time	12:00AM to 11:59PM <1>	12:00AM <1>
S2-06	Sequence Timer 2 Start Time	12:00AM to 11:59PM <1>	12:00AM <1>
S2-11	Sequence Timer 3 Start Time	12:00AM to 11:59PM <1>	12:00AM <1>
S2-16	Sequence Timer 4 Start Time	12:00AM to 11:59PM <1>	12:00AM <1>

<1> Default is 00:00 and range is 00:00 to 24:00 when o4-20 is set to 1 (24-hour).

### ■ S2-04/S2-09/S2-14/S2-19: Sequence Timers 1/2/3/4 Selection

Sets the action that occurs when sequence timers 1 to 4 are active.

- Note:**
1. Setting 3 is available in drive software versions PRG: 8552 and later.
  2. Setting 3 is not available in drive models 4A0930 and 4A1200.

No.	Name	Setting Range	Default
S2-04	Sequence Timer 1 Selection	0 to 3	0
S2-09	Sequence Timer 2 Selection	0 to 3	0
S2-14	Sequence Timer 3 Selection	0 to 3	0
S2-19	Sequence Timer 4 Selection	0 to 3	0

#### Setting 0: Digital Output Only

#### Setting 1: Run

#### Setting 2: Run - PI Disable

#### Setting 3: Allow Alternation

When Sequence Selection is set to Allow Alternation and that timer is enabled (S2-03, S2-08, S2-13, S2-18 > 0), the drive will only allow MEMOBUS alternation to occur during the time specified in the corresponding Sequence Timer. Alternation is disabled when the timer deactivates.

## 4.8 Test Run with No Load

### ◆ No-Load Operation Test Run

This section explains how to operate the drive with the motor decoupled from the load during a test run.

#### ■ Before Starting the Motor

Check the following items before operation:

- Ensure the area around the motor is safe.
- Ensure external emergency stop circuitry is working properly and other safety precautions have been taken.







#### ■ During Operation

Check the following items during operation:

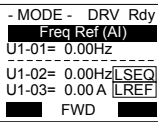
- The motor should rotate smoothly (i.e., no abnormal noise or oscillation).
- The motor should accelerate and decelerate smoothly.

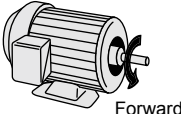
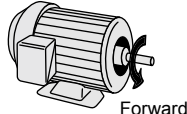
#### ■ No-Load Operation Instructions

The following example illustrates a test run procedure using the HOA keypad.

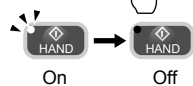
	Step		Display/Result
1.	Before starting the motor, set parameter d1-01, Frequency Reference, to 6 Hz. The Run command from AUTO mode must be OFF.	-	-
2.	Turn on the power to the drive. The initial display appears.	→	
3.	Press  to give the drive a Run command from HAND mode. The HAND light will turn on and the motor will rotate at 6 Hz.	→	 
4.	Ensure the motor is rotating in the correct direction and that no faults or alarms occur.	→	
5.	If there is no error in step 3, press  to increase the frequency reference. Increase the frequency in increments of 10 Hz, verifying smooth operation at all speeds. For each frequency, check the drive output current using monitor U1-03. The current should be well below the motor rated current.	-	-
6.	The drive should operate normally. Press  to stop the motor. The HAND light is OFF and the motor coasts to stop.	→	 

## 4.9 Test Run with Load Connected

### ◆ Test Run with the Load Connected

After performing a no-load test run, connect the motor and proceed to run the motor and load together.

### ■ Precautions for Connected Machinery

**WARNING!** *Sudden Movement Hazard. Clear all personnel from the drive, motor, and machine area before applying power. System may start unexpectedly upon application of power, causing death or serious injury.*

**WARNING!** *Sudden Movement Hazard. Always check the operation of any fast stop circuits after they are wired. Fast stop circuits are required to provide safe and quick shutdown of the drive. Prepare to initiate an emergency stop during the test run. Operating a drive with untested emergency circuits could result in death or serious injury.*

- The motor should come to a complete stop without problems.
- Connect the load and machinery to the motor.
- Fasten all installation screws properly and check that the motor and connected machinery are held in place.

### ■ Checklist Before Operation

- The motor should rotate in the proper direction.
- The motor should accelerate and decelerate smoothly.

### ■ Operating the Motor under Loaded Conditions

Test run the application similarly to the no-load test procedure when connecting the machinery to the motor.

- Monitor U1-03 for overcurrent during operation.
- If the application permits running the load in the reverse direction, change the motor direction and the frequency reference while watching for abnormal motor oscillation or vibration.
- Correct any problems that occur with hunting, oscillation, and other control-related issues.

**This Page Intentionally Blank**



# Troubleshooting

---

This chapter provides descriptions of the drive faults, alarms, errors, and messages. Guidance information for troubleshooting is also included. This chapter can also serve as a reference guide for tuning the drive during a trial run.

<b>5.1</b>	<b>DRIVE ALARMS, FAULTS, ERRORS, AND MESSAGES.....</b>	<b>250</b>
<b>5.2</b>	<b>FAULT DETECTION.....</b>	<b>251</b>
<b>5.3</b>	<b>ALARM DETECTION.....</b>	<b>270</b>
<b>5.4</b>	<b>OPERATOR PROGRAMMING ERRORS.....</b>	<b>285</b>
<b>5.5</b>	<b>AUTO-TUNING FAULT DETECTION.....</b>	<b>290</b>
<b>5.6</b>	<b>COPY FUNCTION RELATED DISPLAYS.....</b>	<b>293</b>
<b>5.7</b>	<b>HOA KEYPAD DISPLAY MESSAGES.....</b>	<b>295</b>
<b>5.8</b>	<b>AUTO-TUNING.....</b>	<b>297</b>

## 5.1 Drive Alarms, Faults, Errors, and Messages

### ◆ Types of Alarms, Faults, and Errors

Check the HOA keypad for information about possible faults if the drive or motor fails to operate. *Refer to Using the HOA Keypad on page 139.*

If problems occur that are not covered in this manual, contact the nearest Yaskawa representative with the following information:

- Drive model
- Software version
- Date of purchase
- Description of the problem
- List of modified parameters.

*Table 5.1* contains descriptions of the various types of alarms, faults, and errors that may occur while operating the drive.

**Table 5.1 Types of Alarms, Faults, and Errors**

Type	Drive Response
<b>Faults</b>	<p>When the drive detects a fault:</p> <ul style="list-style-type: none"> <li>• The HOA keypad displays text indicating the specific fault and the ALM indicator LED remains lit until the fault is reset.</li> <li>• The fault interrupts drive output and the motor coasts to a stop.</li> <li>• Some faults allow the user to select the stopping method when the fault occurs.</li> <li>• Fault output terminals MA-MC will close, and MB-MC will open.</li> </ul> <p>The drive will remain inoperable until the fault is cleared. <i>Refer to Fault Reset Methods on page 296.</i></p>
<b>Minor Faults and Alarms</b>	<p>When the drive detects an alarm or a minor fault:</p> <ul style="list-style-type: none"> <li>• The HOA keypad displays text indicating the specific alarm or minor fault, and the ALM indicator LED flashes.</li> <li>• The drive continues running the motor, although some alarms allow the user to select a stopping method when the alarm occurs.</li> <li>• A multi-function contact output set to be tripped by a minor fault (H2- □□ = 10) closes. If the output is set to be tripped by an alarm, the contact will not close.</li> <li>• The HOA keypad displays text indicating a specific alarm and the ALM indicator LED flashes.</li> </ul> <p>Remove the cause of the problem to reset a minor fault or alarm.</p>
<b>Operation Errors</b>	<p>An operation error occurs when parameter settings conflict or do not match hardware settings (such as with an option card). When the drive detects an operation error:</p> <ul style="list-style-type: none"> <li>• The HOA keypad displays text indicating the specific error.</li> <li>• Multi-function contact outputs do not operate.</li> </ul> <p>The drive will not operate the motor until the error has been reset. Correct the settings that caused the operation error to clear the error.</p>
<b>Tuning Errors</b>	<p>Tuning errors occur while performing Auto-Tuning. When the drive detects a tuning error:</p> <ul style="list-style-type: none"> <li>• The HOA keypad displays text indicating the specific error.</li> <li>• Multi-function contact outputs do not operate.</li> <li>• Motor coasts to stop.</li> </ul> <p>Remove the cause of the error and repeat the Auto-Tuning process.</p>
<b>Copy Function Errors</b>	<p>Copy Function Errors occur when using the HOA keypad or the USB Copy Unit to copy, read, or verify parameter settings.</p> <ul style="list-style-type: none"> <li>• The HOA keypad displays text indicating the specific error.</li> <li>• Multi-function contact outputs do not operate.</li> </ul> <p>Pressing any key on the HOA keypad will clear the fault. Investigate the cause of the problem (such as model incompatibility) and try again.</p>
<b>HOA Keypad Display Messages</b>	<p>The drive will display messages on the HOA keypad to indicate temporary drive statuses during normal pump operation. Messages do not require any action from the user and will clear from the HOA keypad display automatically.</p>

## 5.2 Fault Detection

### ◆ Fault Displays, Causes, and Possible Solutions

Faults are detected for drive protection, and cause the drive to stop while triggering the fault output terminal MA-MB-MC. Remove the cause of the fault and manually clear the fault before attempting to run the drive again.

**Table 5.2 Detailed Fault Displays, Causes, and Possible Solutions**

HOA Keypad Display	Fault Name
ACCUM Accum Level	Accumulated Level Fault
<b>Cause</b>	<b>Possible Solution</b>
The accumulated level has exceeded the values set in P6-11 to P6-14. This is only effective when P6-15, Accumulated Behavior is set to 2 (fault with manual monitor reset) or 3 (fault with automatic monitor reset).	Set the Accumulated Level fault characteristics in P6-11 to P6-14 and P6-16. Drive response to this condition is controlled by P6-15, Accumulated Behavior. Auto-restart of this fault is controlled by P6-15, Accumulated Behavior and P6-05, Flow Accumulation Reset.
HOA Keypad Display	Fault Name
AJF Anti-Jam Fault	Anti-Jam Fault
<b>Cause</b>	<b>Possible Solution</b>
The drive was not able to clear debris from the impeller in fewer than the number of attempts set in P7-02. This is only effective when P7-01, Anti-jam Operation is set to 1 (enabled).	<ul style="list-style-type: none"> <li>• Check for proper pump operation. Remove debris from the pump impeller.</li> <li>• Set the Anti-jam fault characteristics in P7-02 to P7-08.</li> <li>• Drive response to this condition is controlled by P7-01, Anti-jam Operation Selection.</li> </ul>
HOA Keypad Display	Fault Name
AUXFB PI Aux Lvl Loss	Wire-break detection for PI Aux Feedback Level
<b>Cause</b>	<b>Possible Solution</b>
The analog input programmed for "PI Aux FB Level" (H3-□□ = 27) has dropped below 3 mA or risen above 21 mA for longer than 1 second.	Repair transducer or wiring.
HOA Keypad Display	Fault Name
bAT	Digital Operator Battery Voltage Low
<b>Cause</b>	<b>Possible Solution</b>
The digital operator battery is low	Replace the digital operator battery.
HOA Keypad Display	Fault Name
boL	Braking Transistor Overload Fault
<b>Cause</b>	<b>Possible Solution</b>
The wrong braking resistor is installed	Select the correct braking resistor.
HOA Keypad Display	Fault Name
bUS	Option Communication Error
<b>Cause</b>	<b>Possible Solution</b>
No signal was received from the PLC	<ul style="list-style-type: none"> <li>• The connection was lost after establishing initial communication.</li> <li>• Only detected when the run command frequency reference is assigned to an option card.</li> </ul>
Faulty communications wiring or an existing short circuit	<ul style="list-style-type: none"> <li>• Check for faulty wiring.</li> <li>• Correct the wiring.</li> <li>• Check for disconnected cables and short circuits and repair as needed.</li> </ul>

## 5.2 Fault Detection

HOA Keypad Display	Fault Name
Communication data error occurred due to noise	<ul style="list-style-type: none"> <li>• Check the various options available to minimize the effects of noise.</li> <li>• Counteract noise in the control circuit, main circuit, and ground wiring.</li> <li>• Ensure that other equipment such as switches or relays do not cause noise. Use surge absorbers if necessary.</li> <li>• Use only recommended cables or other shielded line. Ground the shield on the controller side or the drive input power side.</li> <li>• Separate all communication wiring from drive power lines. Install an EMC noise filter to the drive power supply input.</li> </ul>
The option card is damaged	Replace the option card if there are no problems with the wiring and the error continues to occur.
The option card is not properly connected to the drive	<ul style="list-style-type: none"> <li>• The connector pins on the option card do not line up properly with the connector pins on the drive.</li> <li>• Reinstall the option card.</li> </ul>

HOA Keypad Display	Fault Name
CE	MEMOBUS/Modbus Communication Error
	Control data was not received for the CE detection time set to H5-09.
<b>Cause</b>	<b>Possible Solution</b>
Faulty communications wiring or an existing short circuit	<ul style="list-style-type: none"> <li>• Check for faulty wiring.</li> <li>• Correct the wiring.</li> <li>• Check for disconnected cables and short circuits and repair as needed.</li> </ul>
Communication data error occurred due to noise	<ul style="list-style-type: none"> <li>• Check the various options available to minimize the effects of noise.</li> <li>• Counteract noise in the control circuit, main circuit, and ground wiring.</li> <li>• Use only recommended cables or other shielded line. Ground the shield on the controller side or the drive input power side.</li> <li>• Ensure that other equipment such as switches or relays do not cause noise. Use surge suppressors if required.</li> <li>• Separate all communication wiring from drive power lines. Install an EMC noise filter to the drive power supply input.</li> </ul>

HOA Keypad Display	Fault Name
CPF11 to CPF14 CPF16 to CPF19	Control Circuit Error
<b>Cause</b>	<b>Possible Solution</b>
There is a self-diagnostic error in the control circuit	<ul style="list-style-type: none"> <li>• Cycle power to the drive.</li> <li>• If the problem continues, replace the control board or the entire drive. Contact Yaskawa or a Yaskawa representative for instructions on replacing the control board.</li> </ul>
Connector on the operator is damaged	Replace the operator.

HOA Keypad Display	Fault Name
CPF02	A/D Conversion Error
	An A/D conversion error or control circuit error occurred.
<b>Cause</b>	<b>Possible Solution</b>
Control circuit is damaged	<ul style="list-style-type: none"> <li>• Cycle power to the drive.</li> <li>• If the problem continues, replace the control board or the entire drive. Contact Yaskawa or a Yaskawa representative for instructions on replacing the control board.</li> </ul>

HOA Keypad Display	Fault Name
CPF03	Control Board Connection Error
	Connection error between the control board and the drive
<b>Cause</b>	<b>Possible Solution</b>
There is a connection error	<ul style="list-style-type: none"> <li>• Turn off the power and check the connection between the control board and the drive.</li> <li>• If the problem continues, replace the control board or the entire drive. Contact Yaskawa or a Yaskawa representative for instructions on replacing the control board.</li> </ul>

HOA Keypad Display	Fault Name
Drive fails to operate properly due to noise interference	<ul style="list-style-type: none"> <li>• Check the various options available to minimize the effects of noise.</li> <li>• Counteract noise in the control circuit, main circuit, and ground wiring.</li> <li>• Use only recommended cables or other shielded line. Ground the shield on the controller side or the drive input power side.</li> <li>• Ensure that other equipment such as switches or relays do not cause noise. Use surge suppressors if required.</li> <li>• Separate all communication wiring from drive power lines. Install an EMC noise filter to the drive power supply input.</li> </ul>

HOA Keypad Display	Fault Name
CPF06	EEPROM Memory Data Error
	Error in the data saved to EEPROM
<b>Cause</b>	<b>Possible Solution</b>
There is an error in EEPROM control circuit	<ul style="list-style-type: none"> <li>• Turn off the power and check the connection between the control board and the drive.</li> <li>• If the problem continues, replace the control board or the entire drive. Contact Yaskawa or a Yaskawa representative for instructions on replacing the control board.</li> </ul>
The power supply was switched off while parameters were being saved to the drive	Reinitialize the drive (A1-03 = 2220, 3330).

HOA Keypad Display	Fault Name
CPF07 or CPF08	Terminal Board Connection Error
<b>Cause</b>	<b>Possible Solution</b>
There is a faulty connection between the terminal board and the control board	<ul style="list-style-type: none"> <li>• Turn off the power and reconnect the terminal board.</li> <li>• If the problem continues, replace the control board or the entire drive. Contact Yaskawa or a Yaskawa representative for instructions on replacing the control board.</li> </ul>

HOA Keypad Display	Fault Name
CPF20 or CPF21	Control Circuit Error
<b>Cause</b>	<b>Possible Solution</b>
Hardware is damaged	<ul style="list-style-type: none"> <li>• Cycle power to the drive.</li> <li>• If the problem continues, replace the control board or the entire drive. Contact Yaskawa or a Yaskawa representative for instructions on replacing the control board.</li> </ul>

HOA Keypad Display	Fault Name
CPF22	Hybrid IC Failure
<b>Cause</b>	<b>Possible Solution</b>
Hybrid IC failure on the power board	<ul style="list-style-type: none"> <li>• Cycle power to the drive.</li> <li>• If the problem continues, replace the power board or the entire drive. Contact Yaskawa or a Yaskawa representative for instructions on replacing the power board.</li> </ul>

HOA Keypad Display	Fault Name
CPF23	Control Board Connection Error
	Connection error between the control board and the drive
<b>Cause</b>	<b>Possible Solution</b>
Hardware is damaged	<ul style="list-style-type: none"> <li>• Turn off the power and check the connection between the control board and the drive.</li> <li>• If the problem continues, replace the control board or the entire drive. Contact Yaskawa or a Yaskawa representative for instructions on replacing the control board.</li> </ul>

HOA Keypad Display	Fault Name
CPF24	Drive Unit Signal Fault
	The drive capacity cannot be detected correctly (drive capacity is checked when the drive is powered up).
<b>Cause</b>	<b>Possible Solution</b>
Hardware is damaged	If the problem continues, replace the control board or the entire drive. Contact Yaskawa or a Yaskawa representative for instructions on replacing the control board.

HOA Keypad Display	Fault Name
CPF25	Terminal Board Not Connected
<b>Cause</b>	<b>Possible Solution</b>

## 5.2 Fault Detection

HOA Keypad Display	Fault Name
Terminal board is not connected correctly	Reconnect the terminal board to the connector on the drive, then cycle the power to the drive.

HOA Keypad Display	Fault Name
CPF26 to CPF35 CPF40 to CPF43	Control Circuit Error CPU error
<b>Cause</b>	<b>Possible Solution</b>
Hardware is damaged	If the problem continues, replace the control board or the entire drive. Contact Yaskawa or a Yaskawa representative for instructions on replacing the control board.

HOA Keypad Display	Fault Name
DIFF Differential Det	Differential Feedback Detected
<b>Cause</b>	<b>Possible Solution</b>
The difference between the PID Feedback and the Differential Feedback (H3-□□ = 28) exceeded the P4-18 level for the time set in P4-19.	<ul style="list-style-type: none"> <li>• Replace the feedback transducer or transducers.</li> <li>• Verify parameter settings P4-18 to P4-20.</li> </ul>

HOA Keypad Display	Fault Name
E5	SI-T3 Watchdog Timer Error The watchdog timed out.
<b>Cause</b>	<b>Possible Solution</b>
Data has not been received from the PLC	Execute DISCONNECT or ALM_CLR, then issue a CONNECT command or SYNC_SET command and proceed to phase 3. Refer to the SI-T3 Option Technical Manual for more details on troubleshooting.

HOA Keypad Display	Fault Name
EF0	Option Card External Fault An external fault condition is present.
<b>Cause</b>	<b>Possible Solution</b>
An external fault was received from the PLC and F6-03 ≠ 3.	<ul style="list-style-type: none"> <li>• Remove the cause of the external fault.</li> <li>• Remove the external fault input from the PLC.</li> </ul>
Problem with the PLC program	Check the PLC program and correct problems.

HOA Keypad Display	Fault Name
EF1	Pump Fault (input terminal S1) External fault at multi-function input terminal S1.
EF2	Pump Fault (input terminal S2) External fault at multi-function input terminal S2.
EF3	Pump Fault (input terminal S3) External fault at multi-function input terminal S3.
EF4	Pump Fault (input terminal S4) External fault at multi-function input terminal S4.
EF5	Pump Fault (input terminal S5) External fault at multi-function input terminal S5.
EF6	Pump Fault (input terminal S6) External fault at multi-function input terminal S6.
EF7	Pump Fault (input terminal S7) External fault at multi-function input terminal S7.
EF8	Pump Fault (input terminal S8) External fault at multi-function input terminal S8.
<b>Cause</b>	<b>Possible Solution</b>
An external device tripped an alarm function	Remove the cause of the external fault and reset the fault.

HOA Keypad Display	Fault Name
Wiring is incorrect	<ul style="list-style-type: none"> <li>Properly connect the signal lines to the terminals assigned for external fault detection (H1-□□ = 20 to 2B).</li> <li>Reconnect the signal line.</li> </ul>
Multi-function contact input setting is incorrect	<ul style="list-style-type: none"> <li>Check for unused terminals set for H1-□□ = 20 to 2B (External Fault).</li> <li>Change the terminal settings.</li> </ul>

HOA Keypad Display	Fault Name
Err	EEPROM Write Error
	Data cannot be written to the EEPROM
Cause	Possible Solution
Noise has corrupted data while writing to the EEPROM	<ul style="list-style-type: none"> <li>Press "ENTER" on the digital operator.</li> <li>Correct the parameter setting.</li> <li>Cycle power to the drive.</li> <li>If the problem continues, replace the control board or the entire drive. Contact Yaskawa or a Yaskawa representative for instructions on replacing the control board.</li> </ul>
Hardware problem	If the problem continues, replace the control board or the entire drive. Contact Yaskawa or a Yaskawa representative for instructions on replacing the control board.

HOA Keypad Display	Fault Name
FAn	Internal Fan Fault
	Fan or magnetic contactor failure
Cause	Possible Solution
Internal cooling fan has malfunctioned	<ul style="list-style-type: none"> <li>Cycle power to the drive.</li> <li>Check for fan operation.</li> <li>Verify the cumulative operation time of the fan with monitor U4-03, and verify the cumulative operation time of the fan maintenance timer with U4-04.</li> <li>If the cooling fan has exceeded its expected performance life or is damaged in any other way, follow the replacement instructions in the <i>Peripheral Devices &amp; Options</i> chapter.</li> </ul>
Fault detected in the internal cooling fan or magnetic contactor to the power supply.	<ul style="list-style-type: none"> <li>Cycle power to the drive.</li> <li>If the fault continues to occur, replace the power board/gate drive board or the entire drive.</li> <li>Contact Yaskawa or a Yaskawa representative for instructions on replacing the power board/gate drive board.</li> </ul>

HOA Keypad Display	Fault Name
FDBKL Wire Break	PID Feedback Loss
	The analog input programmed for PID feedback has risen above 21 mA or fallen below 3 mA.
Cause	Possible Solution
The analog input programmed for PID feedback loss has risen above 21 mA or fallen below 3 mA. This is effective only when b5-12 Feedback Loss 4 to 20 mA Detection Selection is set to 2 (fault).	<ul style="list-style-type: none"> <li>Confirm that the PID feedback source is installed and working properly.</li> <li>Drive response to this condition is controlled by b5-12, Feedback Loss 4 to 20 mA Detection Selection and b5-13, Feedback Loss Go To Frequency.</li> <li>Auto-restart of this fault is controlled by L5-42, Feedback Loss Fault Retry Selection.</li> </ul>

HOA Keypad Display	Fault Name
Flow Rate Limit	Drive output speed is being limited due to the Flow Rate (U1-83).
Cause	Possible Solution
Excessive or insufficient Flow.	If Flow Rate Limiter is activating improperly, confirm parameter settings P6-01, P6-26, P6-27, P6-28, and P6-29.

HOA Keypad Display	Fault Name
GF	Ground Fault
	<ul style="list-style-type: none"> <li>A current short to ground exceeded 50% of rated current on the output side of the drive.</li> <li>Setting L8-09 to 1 enables ground fault detection.</li> </ul>
Cause	Possible Solution
Motor insulation is damaged	<ul style="list-style-type: none"> <li>Check the insulation resistance of the motor.</li> <li>Replace the motor.</li> </ul>

## 5.2 Fault Detection

HOA Keypad Display	Fault Name
A damaged motor cable is creating a short circuit	<ul style="list-style-type: none"> <li>• Check the motor cable.</li> <li>• Remove the short circuit and reapply power to the drive</li> <li>• Check the resistance between the cable and the ground terminal ⊕.</li> <li>• Replace the cable.</li> </ul>
Excessive leakage current at the drive output	<ul style="list-style-type: none"> <li>• Reduce the carrier frequency.</li> <li>• Reduce the amount of stray capacitance.</li> </ul>
The drive started to run during a current offset fault or while coasting to a stop	<ul style="list-style-type: none"> <li>• Set b3-01 to 1 to enable Speed Search at Start.</li> <li>• Perform Speed Search 1 or 2 (H1-□□ = 61 or 62) via one of the external terminals.</li> </ul>
Hardware problem	If the problem continues, replace the control board or the entire drive. Contact Yaskawa or a Yaskawa representative for instructions on replacing the control board.

HOA Keypad Display	Fault Name
HFB	High Feedback
	The feedback signal is too high.
<b>Cause</b>	<b>Possible Solution</b>
The feedback signal has risen above the level set in P1-11, High Feedback Level, for the time set in P1-12, High Feedback Level Fault Delay Time. This is effective only when P1-13, High Feedback Selection, is set to 0 (Fault and digital outt).	<ul style="list-style-type: none"> <li>• Set the High Feedback fault characteristics in P1-11 and P1-12.</li> <li>• Drive response to this condition is controlled by P1-13, High Feedback Selection. Auto-restart of this fault is controlled by L5-41, High Feedback Fault Retry Selection.</li> </ul>

HOA Keypad Display	Fault Name
HIAUX High PI Aux Lvl	High PI Auxiliary Feedback Level
<b>Cause</b>	<b>Possible Solution</b>
PI Aux Feedback has risen above the Q6-12 level for longer than the time set in Q6-13 and the drive is running inAUTO, and output frequency is greater than zero.	<ul style="list-style-type: none"> <li>• Lower the PI Aux Feedback level</li> <li>• Adjust parameters Q6-12 and Q6-13.</li> </ul>

HOA Keypad Display	Fault Name
HIFLO High Flow	High Flow
	The meter has detected a high flow condition.
<b>Cause</b>	<b>Possible Solution</b>
The flow is too high	Reduce the flow
The measured water flow has risen above the P6-17 level for the time set in P6-18. This is only effective when P6-19, High Flow Select is set to 2 (fault).	<ul style="list-style-type: none"> <li>• Set the High Flow fault characteristics in P6-17 and P6-18.</li> <li>• Drive response to this condition is controlled by P6-19, High Flow Select.</li> <li>• Auto-restart of this fault is controlled by P6-19, High Flow Select.</li> </ul>

HOA Keypad Display	Fault Name
HISUC High Suction	High Section Pressure
<b>Cause</b>	<b>Possible Solution</b>
The suction pressure has risen above the level set in Q5-12 for longer than the time set in Q5-13. This is only effective when Q5-14, High Suction Pressure Behavior Select, is set to 2 (fault).	<ul style="list-style-type: none"> <li>• Reduce the system pressure.</li> <li>• Set the High Suction Pressure fault characteristics in Q5-12, Q5-13, and Q5-18.</li> <li>• Drive response to this condition is controlled by Q5-14, High Suction Pressure Behavior Select.</li> <li>• Auto-restart of this fault is controlled by Q5-14, High Suction Pressure Behavior Select and Q5-15, Suction Pressure Auto-restart Time.</li> </ul>

HOA Keypad Display	Fault Name
HWL	High Water Level
	The “High Water Level” digital input is active (H1-0□ = 90).
<b>Cause</b>	<b>Possible Solution</b>
The Low Water Level switch is activated or P1-31, High Water Digital Input Configuration, is programmed incorrectly.	Lower the water level and/or adjust the High Water Level switch.



HOA Keypad Display	Fault Name
LF	Output Phase Loss <ul style="list-style-type: none"> <li>Phase loss on the output side of the drive.</li> <li>Setting L8-07 to 1 or 2 enables Phase Loss Detection.</li> </ul>
<b>Cause</b>	<b>Possible Solution</b>
The output cable is disconnected	<ul style="list-style-type: none"> <li>Check for wiring errors and properly connect the output cable.</li> <li>Correct the wiring.</li> </ul>
The motor winding is damaged	<ul style="list-style-type: none"> <li>Check the resistance between motor lines.</li> <li>Replace the motor if the winding is damaged.</li> </ul>
The output terminal is loose	<ul style="list-style-type: none"> <li>Apply the tightening torque specified in this manual to fasten the terminals. <i>Refer to Main Circuit Wire Gauges and Tightening Torques on page 110</i> for details.</li> </ul>
The rated current of the motor being used is less than 5% of the drive rated current	Check the drive and motor capacities.
An output transistor is damaged	If the problem continues, replace the control board or the entire drive. Contact Yaskawa or a Yaskawa representative for instructions on replacing the control board.
A single-phase motor is being used	The drive cannot operate a single phase motor.

HOA Keypad Display	Fault Name
LF3 <I>	Power Unit Output Phase Loss 3 <ul style="list-style-type: none"> <li>Phase loss occurred on the output side</li> <li>Setting L8-78 to 1 enables Power Unit Output Phase Loss Protection</li> </ul>
<b>Cause</b>	<b>Possible Solution</b>
The gate drive board in the power unit is damaged.	Cycle the power supply. If the fault continues to occur, replace the gate drive board or the drive. Contact Yaskawa or a Yaskawa representative for instructions on replacing the gate drive board.
Cable to the current detection circuit in the power unit is damaged or not connected properly.	Check for incorrect wiring and correct any wiring mistakes.
Cable between the output rectifier and the power unit is loose or not connected.	Contact Yaskawa or your nearest sales representative for instructions.

<I> Detected in models 4A0930 and 4A1200.

HOA Keypad Display	Fault Name
LFB	Low Feedback The feedback signal is too low.
<b>Cause</b>	<b>Possible Solution</b>
The feedback signal has dropped below the level set in P1-08, Low Feedback Level, for the time set in P1-09, Low Feedback Level Fault Delay Time. This is effective only when P1-10, Low Feedback Selection, is set to 0 (Fault and digital out).	<ul style="list-style-type: none"> <li>Set the Low Feedback fault characteristics in P1-08 and P1-09.</li> <li>Drive response to this condition is controlled by P1-10, Low Feedback Selection.</li> <li>Auto-restart of this fault is controlled by L5-40, Low Feedback Fault Retry Selection.</li> </ul>

HOA Keypad Display	Fault Name
LOAUX Low PI Aux Lvl	Low PI Auxiliary Feedback Level
<b>Cause</b>	<b>Possible Solution</b>
PI Aux Feedback has fallen below the Q6-09 level for longer than the time set in Q6-10 and the drive is running in HAND or AUTO.	<ul style="list-style-type: none"> <li>Raise the PI Aux Feedback level</li> <li>Adjust parameters Q6-09 and Q6-10.</li> </ul>

HOA Keypad Display	Fault Name
LOP	Loss of Prime The pump has lost its prime.
<b>Cause</b>	<b>Possible Solution</b>

## 5.2 Fault Detection

HOA Keypad Display	Fault Name
The pump load, measured based on the P1-18 setting (output current, kilowatts, or power), has dropped below the level set in P1-19, Prime Loss Level, for the time set in P1-20, Loss of Prime Time, and the output frequency has risen above P1-21, Prime Loss Frequency. This is effective only when P1-22 Loss of Prime Selection is set to 0 (fault).	<ul style="list-style-type: none"> <li>• Check for a dry well, air in the system, or no water in the system. Restart the pump using the preferred priming method suggested by the pump manufacturer.</li> <li>• Set the Loss of Prime fault characteristics in P1-18, P1-19, P1-20, and P1-21.</li> <li>• Drive response to this condition is controlled by P1-21, Loss of Prime Selection.</li> <li>• Auto-restart of this fault is controlled by L5-51, Loss of Prime Fault Retry Selection and P1-23, Loss of Prime Maximum Restart Time after Fault</li> </ul>

HOA Keypad Display	Fault Name
LOSUC Low Suction	Low Section Pressure
<b>Cause</b>	<b>Possible Solution</b>
The suction pressure has fallen below the level set in Q5-09 for longer than the time set in Q5-10. This is only effective when Q5-11, Low Suction Pressure Behavior Select is set to 2 (fault).	<ul style="list-style-type: none"> <li>• Increase the system pressure.</li> <li>• Set the Low Suction fault characteristics in Q5-09, Q5-10, and Q5-18.</li> <li>• Drive response to this condition is controlled by Q5-11, Low Suction Pressure Behavior Select.</li> <li>• Auto-restart of this fault is controlled by Q5-11, Low Suction Pressure Behavior Select and Q5-15, Suction Pressure Auto-restart Time.</li> </ul>

HOA Keypad Display	Fault Name
LOWFL Low Flow	Low Flow
<b>Cause</b>	<b>Possible Solution</b>
Insufficient flow	Increase flow
After waiting the P6-08 delay time at start, the measured water flow has fallen below the P6-06 level for the time set in P6-07. This is only effective when P1-09, Low Flow Select is set to 2 (fault).	<ul style="list-style-type: none"> <li>• Set the Low Flow fault characteristics in P6-06, P6-07, and P6-08.</li> <li>• Drive response to this condition is controlled by P6-09, Low Flow Select.</li> <li>• Auto-restart of this fault is controlled by P6-09, Low Flow Select and P6-10, Low Flow Auto-restart Time.</li> </ul>

HOA Keypad Display	Fault Name
LOWWL Low Water Level	Low Water Level
<b>Cause</b>	<b>Possible Solution</b>
The water level has fallen below the level set in Q4-09 for the longer than the time set in Q4-10. This is only effective when Q4-11, Low Level Behavior is set to 2 (fault).	<ul style="list-style-type: none"> <li>• Raise the water level.</li> <li>• Set the Low Water Level fault characteristics in Q4-09 and Q4-10.</li> <li>• Drive response to this condition is controlled by Q4-11, Low Level Behavior.</li> <li>• Auto-restart of this fault is controlled by Q4-11, Low Level Behavior and Q4-12 Water Level Control Auto-restart Time.</li> </ul>

HOA Keypad Display	Fault Name
LWL	Low Water Level
<b>Cause</b>	<b>Possible Solution</b>
The Low Water Level switch is activated, defective, or P1-30, Low Water Digital Input Configuration, is programmed incorrectly.	Raise the water level and/or adjust the Low Water Level switch.

HOA Keypad Display	Fault Name
MSL Net Master Lost	Net Master Lost
<b>Cause</b>	<b>Possible Solution</b>
Network Recovery is set to Fault MSL (P9-27 = 3) and no message has been received from the master within the time set in P9-26.	<ul style="list-style-type: none"> <li>• Increase the P9-26 setting to account for network latency.</li> <li>• Verify that there is a drive on the network with parameter P1-01 set to 3 and P9-27 to 0.</li> <li>• Check network connections and verify H5-01 and P9-25 settings for all drives on the network.</li> </ul>

HOA Keypad Display	Fault Name
NMS	Not Maintaining Setpoint
	The setpoint cannot be maintained and P1-17 is set to 0.
<b>Cause</b>	<b>Possible Solution</b>
When the feedback deviates from the setpoint at a level greater than P1-15, for a time set in P1-16. This is effective only when P1-17 is set to 0 (fault).	<ul style="list-style-type: none"> <li>• Check for a blocked impeller, over cycling, or broken pipe.</li> <li>• Set the Not Maintaining Setpoint fault characteristics in P1-16 and P1-17.</li> <li>• Drive response to this condition is controlled by P1-17, Not Maintaining Setpoint Selection.</li> <li>• Auto-restart of this fault is controlled by L5-50, Setpoint Not Met Retry.</li> </ul>
HOA Keypad Display	Fault Name
nSE	Node Setup Error
	A terminal assigned to the node setup function closed during run.
<b>Cause</b>	<b>Possible Solution</b>
The node setup terminal closed during run.	Stop the drive when using the node setup function.
A Run command was issued while the node setup function was active.	
HOA Keypad Display	Fault Name
oC	Overcurrent
	Drive sensors detected an output current greater than the specified overcurrent level.
<b>Cause</b>	<b>Possible Solution</b>
The motor has been damaged due to overheating or the motor insulation is damaged	<ul style="list-style-type: none"> <li>• Check the insulation resistance.</li> <li>• Replace the motor.</li> </ul>
One of the motor cables has shorted out or there is a grounding problem	<ul style="list-style-type: none"> <li>• Check the motor cables.</li> <li>• Remove the short circuit and reapply power to the drive.</li> </ul>
	<ul style="list-style-type: none"> <li>• Check the resistance between the motor cables and the ground terminal ⊕.</li> <li>• Replace damaged cables.</li> </ul>
The load is too heavy	<ul style="list-style-type: none"> <li>• Measure the current flowing into the motor.</li> <li>• Replace the drive with a larger capacity drive if the current value exceeds the rated current.</li> <li>• Determine if there is sudden fluctuation in the current level.</li> <li>• Reduce the load to avoid sudden changes in the current level or switch to a larger drive.</li> </ul>
The acceleration or deceleration times are too short	<p>Calculate the torque needed during acceleration relative to the load inertia and the specified acceleration time. If it is not possible to set the proper amount of torque, make the following changes:</p> <ul style="list-style-type: none"> <li>• Increase the acceleration time (C1-01, C1-03).</li> <li>• Increase the S-curve characteristics (C2-01 through C2-04).</li> <li>• Increase the capacity of the drive.</li> </ul>
The drive is attempting to operate a specialized motor or a motor larger than the maximum size allowed	<ul style="list-style-type: none"> <li>• Check the motor capacity.</li> <li>• Ensure that the rated capacity of the drive is greater than or equal to the capacity rating found on the motor nameplate.</li> </ul>
Magnetic contactor (MC) on the output side of the drive has turned on or off	Set up the operation sequence so the MC does not trip while the drive is outputting current.
V/f setting is not operating as expected	<ul style="list-style-type: none"> <li>• Check the ratios between the voltage and frequency.</li> <li>• Set parameters E1-04 through E1-10 appropriately.</li> <li>• Lower the voltage if it is too high relative to the frequency.</li> </ul>
Excessive torque compensation	<ul style="list-style-type: none"> <li>• Check the amount of torque compensation.</li> <li>• Reduce the torque compensation gain (C4-01) until there is no speed loss and less current.</li> </ul>
Drive fails to operate properly due to noise interference	<ul style="list-style-type: none"> <li>• Review the possible solutions provided for handling noise interference.</li> <li>• Review the section on handling noise interference and check the control circuit lines, main circuit lines, and ground wiring.</li> </ul>
Overexcitation gain is set too high	<ul style="list-style-type: none"> <li>• Check if the fault occurs simultaneously with overexcitation function operation.</li> <li>• Consider motor flux saturation and reduce the value of n3-13 (Overexcitation Deceleration Gain).</li> </ul>
Run command was applied while motor was coasting	<ul style="list-style-type: none"> <li>• Set b3-01 to 1 to enable Speed Search at Start.</li> <li>• Program the Speed Search command input through one of the multi-function contact input terminals (H1-□□ = 61 or 62).</li> </ul>
The rated output current of the drive is too small	Use a larger drive.

## 5.2 Fault Detection

HOA Keypad Display	Fault Name
oFA00	Option Card Connection Error at Option Port CN5-A
	Option compatibility error
<b>Cause</b>	<b>Possible Solution</b>
The option card installed into port CN5-A is incompatible with the drive	Check if the drive supports the option card to be installed. Contact Yaskawa for assistance.

HOA Keypad Display	Fault Name
oFA01	Option Card Fault at Option Port CN5-A
	Option not properly connected
<b>Cause</b>	<b>Possible Solution</b>
The option card connection to port CN5-A is faulty	<ul style="list-style-type: none"> <li>Turn off the power and reconnect the option card.</li> <li>Check if the option card is properly plugged into the option port. Make sure the card is fixed properly.</li> <li>If the option is not a communication option card, try to use the card in a different option port. If the option card works properly in a different option port, CN5-A is damaged, and the drive requires replacement. If the error persists (oFb01 or oFC01 occur), replace the option card.</li> </ul>

HOA Keypad Display	Fault Name
oFA03 to oFA06	Option Card Error Occurred at Option Port CN5-A
oFA10, oFA11	
oFA12 to oFA17	Option Card Connection Error (CN5-A)
oFA30 to oFA43	Communication Option Card Connection Error (CN5-A)
<b>Cause</b>	<b>Possible Solution</b>
Option card or hardware is damaged	<ul style="list-style-type: none"> <li>Cycle power to the drive.</li> <li>If the problem continues, replace the control board or the entire drive. Contact Yaskawa or a Yaskawa representative for instructions on replacing the control board.</li> </ul>

HOA Keypad Display	Fault Name
oFb00	Option Card Fault at Option Port CN5-B
	Option compatibility error
<b>Cause</b>	<b>Possible Solution</b>
The option card installed into port CN5-B is incompatible with the drive	Make sure the drive supports the option card to be installed. Contact Yaskawa for assistance.
A communication option card has been installed in option port CN5-B	Communication option cards are only supported by option port CN5-A. It is not possible to install more than one communication option.

HOA Keypad Display	Fault Name
oFb01	Option Card Fault at Option Port CN5-B
	Option not properly connected
<b>Cause</b>	<b>Possible Solution</b>
The option card connection to port CN5-B is faulty	<ul style="list-style-type: none"> <li>Turn off the power and reconnect the option card.</li> <li>Check if the option card is properly plugged into the option port. Make sure the card is fixed properly.</li> <li>Try to use the card in a different option port. If the option card works properly in a different option port, CN5-B is damaged, and the drive requires replacement. If the error persists (oFA01 or oFC01 occur), replace the option card.</li> </ul>

HOA Keypad Display	Fault Name
oFb02	Option Card Fault at Option Port CN5-B
	Same type of option card is currently connected
<b>Cause</b>	<b>Possible Solution</b>
An option card of the same type is already installed in option port CN5-A	Only one of each option card type can only be installed simultaneously. Make sure only one type of option card is connected.
An input option card is already installed in option port CN5-A	Install a communication option. More than one of the same type of card cannot be installed simultaneously.

HOA Keypad Display	Fault Name
oFb03 to oFb11	Option card error occurred at Option Port CN5-B
oFb12 to oFb17	

HOA Keypad Display	Fault Name
Cause	Possible Solution
Option card or hardware is damaged	<ul style="list-style-type: none"> <li>• Cycle power to the drive.</li> <li>• If the problem continues, replace the control board or the entire drive. Contact Yaskawa or a Yaskawa representative for instructions on replacing the control board.</li> </ul>

HOA Keypad Display	Fault Name
oFC00	Option Card Connection Error at Option Port CN5-C
	Option compatibility error
Cause	Possible Solution
The option card installed into port CN5-C is incompatible with the drive	Confirm that the drive supports the option card to be installed. Contact Yaskawa for assistance.
A communication option card has been installed in option port CN5-C	Communication option cards are only supported by option port CN5-A. It is not possible to install more than one communication option.

HOA Keypad Display	Fault Name
oFC01	Option Card Fault at Option Port CN5-C
	Option not properly connected
Cause	Possible Solution
The option card connection to port CN5-C is faulty.	<ul style="list-style-type: none"> <li>• Turn the power off and reconnect the option card.</li> <li>• Check if the option card is properly plugged into the option port. Make sure the card is fixed properly.</li> <li>• Try to use the card in a different option port. If the option card works properly in a different option port, CN5-C is damaged, and the drive requires replacement. If the error persists (oFA01 or oFb01 occur), replace the option card.</li> </ul>

HOA Keypad Display	Fault Name
oFC02	Option Card Fault at Option Port CN5-C
	Same type of option card is currently connected
Cause	Possible Solution
An option card of the same type is already installed in option port CN5-A or CN5-B.	Only one of each option card type can only be installed simultaneously. Make sure only one type of option card is connected.
An input option card is already installed in option port CN5-A or CN5-B.	Install a communication option, a digital input option, or an analog input option. More than one of the same type of card cannot be installed simultaneously.

HOA Keypad Display	Fault Name
oFC03 to oFC11	Option Card Error Occurred at Option Port CN5-C
oFC12 to oFC17	
Cause	Possible Solution
Option card or hardware is damaged	<ul style="list-style-type: none"> <li>• Cycle power to the drive.</li> <li>• If the problem continues, replace the control board or the entire drive. Contact Yaskawa or a Yaskawa representative for instructions on replacing the control board.</li> </ul>

HOA Keypad Display	Fault Name
oFC50 to oFC55	Option Card Error Occurred at Option Port CN5-C
Cause	Possible Solution
Option card or hardware is damaged	Refer to the option manual for details.

HOA Keypad Display	Fault Name
oH	Heatsink Overheat
	The heatsink temperature exceeded the overheat pre-alarm level set to L8-02.
Cause	Possible Solution
Surrounding temperature is too high	<ul style="list-style-type: none"> <li>• Check the temperature surrounding the drive. Verify temperature is within drive specifications.</li> <li>• Improve the air circulation within the enclosure panel.</li> <li>• Install a fan or air conditioner to cool the surrounding area.</li> <li>• Remove anything near the drive that might be producing excessive heat.</li> </ul>
Load is too heavy	<ul style="list-style-type: none"> <li>• Measure the output current.</li> <li>• Decrease the load.</li> <li>• Lower the carrier frequency (C6-02).</li> </ul>

## 5.2 Fault Detection

HOA Keypad Display	Fault Name
Internal cooling fan is stopped	<ul style="list-style-type: none"> <li>• Replace the cooling fan. .</li> <li>• After replacing the cooling fan, set parameter o4-03 to 0 to reset the cooling fan maintenance.</li> </ul>

HOA Keypad Display	Fault Name
oH1	Overheat 1 (Heatsink Overheat) The heatsink temperature exceeded the drive overheat level.
<b>Cause</b>	<b>Possible Solution</b>
Surrounding temperature is too high	<ul style="list-style-type: none"> <li>• Check the temperature surrounding the drive.</li> <li>• Improve the air circulation within the enclosure panel.</li> <li>• Install a fan or air conditioner to cool the surrounding area.</li> <li>• Remove anything near the drive that might be producing excessive heat.</li> </ul>
Load is too heavy	<ul style="list-style-type: none"> <li>• Measure the output current.</li> <li>• Lower the carrier frequency (C6-02).</li> <li>• Reduce the load.</li> </ul>

HOA Keypad Display	Fault Name
oH4	Motor Overheat Fault (PTC Input) <ul style="list-style-type: none"> <li>• The motor overheat signal to analog input terminal A1, A2, or A3 exceeded the fault detection level.</li> <li>• Detection requires setting multi-function analog inputs H3-02, H3-10, or H3-06 to E.</li> </ul>
<b>Cause</b>	<b>Possible Solution</b>
Motor has overheated	<ul style="list-style-type: none"> <li>• Check the size of the load, the accel/decel times, and the cycle times.</li> <li>• Decrease the load.</li> <li>• Increase the acceleration and deceleration times (C1-01 through C1-04).</li> </ul>
	<ul style="list-style-type: none"> <li>• Adjust the preset V/f pattern (E1-04 through E1-10) by reducing E1-08 and E1-10.</li> <li>• Do not set E1-08 and E1-10 too low. This reduces load tolerance at low speeds.</li> <li>• Check the motor rated current.</li> <li>• Enter the motor rated current to parameter E2-01 as indicated on the motor nameplate.</li> <li>• Ensure the motor cooling system is operating normally.</li> <li>• Repair or replace the motor cooling system.</li> </ul>

HOA Keypad Display	Fault Name
oH5 <1>	Motor Overheat (NTC Input) The motor temperature exceeded the level set to L1-16 (or L1-18 for motor 2)
<b>Cause</b>	<b>Possible Solution</b>
Motor has overheated	<ul style="list-style-type: none"> <li>• Reduce the load.</li> <li>• Check the ambient temperature.</li> </ul>

<1> Detected in models 4A0930 and 4A1200.

HOA Keypad Display	Fault Name
oL1	Motor Overload The electronic motor overload protection tripped
<b>Cause</b>	<b>Possible Solution</b>
Load is too heavy	Reduce the load.
Cycle times are too short during acceleration and deceleration	Increase the acceleration and deceleration times (C1-01 through C1-04).
A general-purpose motor is driven below the rated speed with a high load	<ul style="list-style-type: none"> <li>• Reduce the load.</li> <li>• Increase the speed.</li> <li>• If the motor is supposed to operate at low speeds, either increase the motor capacity or use a motor specifically designed to operate in the desired speed range.</li> </ul>
The output voltage is too high	<ul style="list-style-type: none"> <li>• Adjust the user-set V/f pattern (E1-04 through E1-10) by reducing E1-08 and E1-10.</li> <li>• Do not set E1-08 and E1-10 too low. This reduces load tolerance at low speeds.</li> </ul>
The wrong motor rated current is set to E2-01	<ul style="list-style-type: none"> <li>• Check the motor-rated current.</li> <li>• Enter the motor rated current to parameter E2-01 as indicated on the motor nameplate.</li> </ul>
The base frequency is set incorrectly	<ul style="list-style-type: none"> <li>• Check the rated frequency indicated on the motor nameplate.</li> <li>• Enter the rated frequency to E1-06 (Base Frequency).</li> </ul>

HOA Keypad Display	Fault Name
The electrical thermal protection characteristics and motor overload characteristics do not match	<ul style="list-style-type: none"> <li>Check the motor characteristics.</li> <li>Correct the type of motor protection that has been selected (L1-01).</li> <li>Install an external thermal relay.</li> </ul>
The electrical thermal relay is operating at the wrong level	<ul style="list-style-type: none"> <li>Check the current rating listed on the motor nameplate.</li> <li>Check the value set for the motor rated current (E2-01).</li> </ul>
Motor overheated by overexcitation operation	<ul style="list-style-type: none"> <li>Overexcitation increases the motor loss and the motor temperature. Excessive duration of overexcitation may cause motor damage. Prevent excessive overexcitation operation or apply proper cooling to the motor.</li> <li>Reduce the excitation deceleration gain (n3-13).</li> <li>Set L3-04 (Stall Prevention during Deceleration) to a value other than 4.</li> </ul>
Parameters related to Speed Search are set incorrectly	<ul style="list-style-type: none"> <li>Check values set to Speed Search related parameters.</li> <li>Adjust the Speed Search current and Speed Search deceleration times (b3-02 and b3-03 respectively).</li> <li>After Auto-Tuning, set b3-24 to 1 to enable Speed Estimation Speed Search.</li> </ul>
Output current fluctuation due to power supply loss	Check the power supply for phase loss.

HOA Keypad Display	Fault Name
oL2	Drive Overload
	The thermal sensor of the drive triggered overload protection.
<b>Cause</b>	<b>Possible Solution</b>
Load is too heavy	Reduce the load.
Acceleration or deceleration time is too short	Increase the settings for the acceleration and deceleration times (C1-01 through C1-04).
The output voltage is too high	<ul style="list-style-type: none"> <li>Adjust the preset V/f pattern (E1-04 through E1-10) by reducing E1-08 and E1-10.</li> <li>Do not lower E1-08 and E1-10 excessively. This reduces load tolerance at low speeds.</li> </ul>
Drive capacity is too small	Replace the drive with a larger model.
Overload occurred when operating at low speeds	<ul style="list-style-type: none"> <li>Reduce the load when operating at low speeds.</li> <li>Replace the drive with a model that is one frame size larger.</li> <li>Lower the carrier frequency (C6-02).</li> </ul>
Excessive torque compensation	Reduce the torque compensation gain in parameter C4-01 until there is less current but no speed loss.
Parameters related to Speed Search are set incorrectly	<ul style="list-style-type: none"> <li>Check the settings for all Speed Search related parameters.</li> <li>Adjust the current used during Speed Search (b3-03) and the Speed Search deceleration time (b3-02).</li> <li>After Auto-Tuning, set b3-24 to 1 to enable Speed Estimation Speed Search.</li> </ul>
Output current fluctuation due to input phase loss	Check the power supply for phase loss.

HOA Keypad Display	Fault Name
oL3	Overtorque Detection 1
	The current has exceeded the value set for torque detection (L6-02) for longer than the allowable time (L6-03).
<b>Cause</b>	<b>Possible Solution</b>
Parameter settings are not appropriate for the load	Check L6-02 and L6-03 settings.
Fault on the machine side (e.g., machine is locked up)	Check the status of the load. Remove the cause of the fault.

HOA Keypad Display	Fault Name
oL4	Overtorque Detection 2
	The current has exceeded the value set for Overtorque Detection 2 (L6-05) for longer than the allowable time (L6-06).
<b>Cause</b>	<b>Possible Solution</b>
Parameter settings are not appropriate for the load	Check the settings of parameters L6-05 and L6-06.

HOA Keypad Display	Fault Name
oL7	High Slip Braking oL
	The output frequency stayed constant for longer than the time set to n3-04 during High Slip Braking.
<b>Cause</b>	<b>Possible Solution</b>

## 5.2 Fault Detection

HOA Keypad Display	Fault Name
Excessive load inertia	<ul style="list-style-type: none"> <li>• Reduce deceleration times in parameters C1-02 and C1-04 for applications that do not use High Slip Braking.</li> <li>• Use a braking resistor to shorten deceleration time.</li> </ul>
Motor is driven by the load	
Something on the load side is restricting deceleration	
The overload time during High Slip Braking is too short	<ul style="list-style-type: none"> <li>• Increase parameter n3-04 (High-slip Braking Overload Time).</li> <li>• Install a thermal relay and increase the setting of n3-04 to maximum value.</li> </ul>

HOA Keypad Display	Fault Name
oPr	External HOA Keypad Connection Fault
	<p>The HOA keypad has been disconnected from the drive.</p> <p><b>Note:</b> An oPr fault will occur when all of the following conditions are true:</p> <ul style="list-style-type: none"> <li>• Output is interrupted when the keypad is disconnected (o2-06 = 1).</li> <li>• The Run command is assigned to the operator (b1-02 = 0 and LOCAL has been selected).</li> </ul>
<b>Cause</b>	<b>Possible Solution</b>
HOA keypad is not properly connected to the drive	<ul style="list-style-type: none"> <li>• Check the connection between the keypad and the drive.</li> <li>• Replace the cable if damaged.</li> <li>• Turn off the drive input power and disconnect the keypad. Reconnect the keypad and reapply drive input power.</li> </ul>

HOA Keypad Display	Fault Name
ov	Overvoltage
	<p>Voltage in the DC bus has exceeded the overvoltage detection level.</p> <ul style="list-style-type: none"> <li>• For 200 V class drives: approximately 410 V</li> <li>• For 400 V class drives: approximately 820 V (740 V when E1-01 is less than 400)</li> <li>• For 600 V class drives: approximately 1040 V</li> </ul>
<b>Cause</b>	<b>Possible Solution</b>
Deceleration time is too short and regenerative energy is flowing from the motor into the drive	<ul style="list-style-type: none"> <li>• Increase the deceleration time (C1-02 and C1-04).</li> <li>• Install a dynamic braking resistor or a dynamic braking resistor unit.</li> <li>• Set L3-04 to 1 to enable stall prevention during deceleration. Stall Prevention is enabled as the default setting.</li> </ul>
Fast acceleration time causes the motor to overshoot the speed reference	<ul style="list-style-type: none"> <li>• Check if sudden drive acceleration triggers an overvoltage alarm.</li> <li>• Increase the acceleration time.</li> <li>• Use longer S-curve acceleration and deceleration times.</li> <li>• Enable the Overvoltage Suppression function (L3-11 = 1).</li> <li>• Lengthen the S-curve at acceleration end.</li> </ul>
Excessive braking load	The braking torque was too high, causing regenerative energy to charge the DC bus. Reduce the braking torque, use a dynamic braking option, or lengthen decel time.
Surge voltage entering from the drive input power	<p>Install a DC link choke.</p> <p><b>Note:</b> Voltage surge can result from a thyristor convertor and phase advancing capacitor using the same input power supply.</p>
Ground fault in the output circuit causes the DC bus capacitor to overcharge	<ul style="list-style-type: none"> <li>• Check the motor wiring for ground faults.</li> <li>• Correct grounding shorts and reapply power.</li> </ul>
Improper parameters related to Speed Search (including Speed Search after a momentary power loss and after a fault restart)	<ul style="list-style-type: none"> <li>• Check the settings for Speed Search-related parameters.</li> <li>• Enable Speed Search restart function (b3-19 greater than or equal to 1 to 10).</li> <li>• Adjust the current level during Speed Search and the deceleration time (b3-02 and b3-03 respectively).</li> <li>• Perform Stationary Auto-Tuning for line-to-line resistance and then set b3-14 to 1 to enable Speed Estimation Speed Search.</li> </ul>
Drive input power voltage is too high	<ul style="list-style-type: none"> <li>• Check the voltage.</li> <li>• Lower drive input power voltage within the limits listed in the specifications.</li> </ul>
The braking transistor or braking resistor are wired incorrectly	<ul style="list-style-type: none"> <li>• Check braking transistor and braking resistor wiring for errors.</li> <li>• Properly rewire the braking resistor device.</li> </ul>
Drive fails to operate properly due to noise interference	<ul style="list-style-type: none"> <li>• Review the list of possible solutions provided for controlling noise.</li> <li>• Review the section on handling noise interference and check the control circuit lines, main circuit lines, and ground wiring.</li> </ul>



HOA Keypad Display	Fault Name
Load inertia is set incorrectly	<ul style="list-style-type: none"> <li>Check the load inertia settings when using KEB, overvoltage suppression, or Stall Prevention during deceleration.</li> <li>Adjust the load inertia ratio in L3-25 to better match the load.</li> </ul>
Motor hunting occurs	<ul style="list-style-type: none"> <li>Adjust the parameters that control hunting.</li> <li>Set the gain for Hunting Prevention (n1-02).</li> <li>Adjust the AFR time constant (n2-02 and n2-03).</li> </ul>

HOA Keypad Display	Fault Name
PF	Input Phase Loss
	Drive input power has an open phase or has a large imbalance of voltage between phases. Detected when L8-05 is set 1 (enabled).
<b>Cause</b>	<b>Possible Solution</b>
There is phase loss in the drive input power	<ul style="list-style-type: none"> <li>Check for wiring errors in the main circuit drive input power.</li> <li>Correct the wiring.</li> </ul>
There is loose wiring in the drive input power terminals	<ul style="list-style-type: none"> <li>Ensure the terminals are tightened properly.</li> <li>Apply the tightening torque as specified in this manual. <i>Refer to Main Circuit Wire Gauges and Tightening Torques on page 110</i> for details.</li> </ul>
There is excessive fluctuation in the drive input power voltage	<ul style="list-style-type: none"> <li>Check the voltage from the drive input power.</li> <li>Review the possible solutions for stabilizing the drive input power.</li> </ul>
There is poor balance between voltage phases	Stabilize drive input power or disable phase loss detection.
The main circuit capacitors are worn out	<ul style="list-style-type: none"> <li>Check the maintenance time for the capacitors (U4-05).</li> <li>Replace the capacitor if U4-05 is greater than 90%. For instructions on replacing the capacitor, contact Yaskawa or a Yaskawa representative.</li> </ul>
	Check for problems with the drive input power. If drive input power appears normal but the alarm continues to occur, replace either the control board or the entire drive. For instructions on replacing the control board, contact Yaskawa or a Yaskawa representative.

HOA Keypad Display	Fault Name
PoC	Pump Over Cycle
<b>Cause</b>	<b>Possible Solution</b>
The pump has exceeded the number of cycles set in P2-10 in the time set in P2-11 and P2-12 is set to 2 (fault).	<ul style="list-style-type: none"> <li>Set the Pump Over Cycle fault characteristics in P2-10 and P2-11.</li> <li>Drive response to this condition is controlled by P2-12, Over Cycling Mode.</li> <li>Auto-restart of this fault is controlled by L5-52, Pump Over Cycle Fault Retry Selection.</li> <li>Set the Pump Over Cycle automatic setpoint compensation in P2-12, Over Cycling Mode, P2-13, Setpoint Compensation, and P2-14, Maximum Setpoint Compensation.</li> </ul>

HOA Keypad Display	Fault Name
rF	Braking Resistor Fault
	The resistance of the braking resistor is too low.
<b>Cause</b>	<b>Possible Solution</b>
The proper braking resistor option has not been installed	Select a braking resistor option that it fits the drive braking transistor specification.
A regenerative converter, regenerative unit, or braking unit is being used	Set L8-55 to 0 to disable the braking transistor protection selection.

HOA Keypad Display	Fault Name
rH	Braking Resistor Overheat
	Braking resistor protection was triggered. Fault detection is enabled when L8-01 = 1 (disabled as a default).
<b>Cause</b>	<b>Possible Solution</b>
Deceleration time is too short and excessive regenerative energy is flowing back into the drive	<ul style="list-style-type: none"> <li>Check the load, deceleration time, and speed.</li> <li>Reduce the load inertia.</li> <li>Increase the deceleration times (C1-01 to C1-04).</li> <li>Replace the dynamic braking option with a larger device that can handle the power that is discharged.</li> </ul>
The duty cycle is too high	Check the duty cycle. Maximum of 3% duty cycle is available when L8-01 = 1.
Excessive braking inertia	Recalculate braking load and braking power. Reduce the braking load by adjusting braking resistor settings.

## 5.2 Fault Detection

HOA Keypad Display	Fault Name
The braking operation duty cycle is too high	Check the braking operation duty cycle. Braking resistor protection for ERF-type braking resistors (L8-01 = 1) allows a braking duty cycle of maximum 3%.
The proper braking resistor has not been installed	<ul style="list-style-type: none"> <li>• Check the specifications and conditions for the braking resistor device.</li> <li>• Select the optimal braking resistor.</li> </ul>
<b>Note:</b>	The magnitude of the braking load trips the braking resistor overheat alarm, NOT the surface temperature. Using the braking resistor more frequently than its rating permits will trip the alarm even when the braking resistor surface is not very hot.

HOA Keypad Display	Fault Name
rr	Dynamic Braking Transistor
	The built-in dynamic braking transistor failed.
<b>Cause</b>	<b>Possible Solution</b>
The braking transistor is damaged	<ul style="list-style-type: none"> <li>• Cycle power to the drive and check for reoccurrence of the fault.</li> </ul>
The control circuit is damaged	<ul style="list-style-type: none"> <li>• Replace either the control board or the entire drive. For instructions on replacing the control board, contact Yaskawa or a Yaskawa representative.</li> </ul>

HOA Keypad Display	Fault Name
SC	IGBT Short Circuit or Ground Fault
<b>Cause</b>	<b>Possible Solution</b>
IGBT fault	<ul style="list-style-type: none"> <li>• Check motor wiring.</li> </ul>
IGBT short circuit detection circuit fault	<ul style="list-style-type: none"> <li>• Turn off the power supply, then turn it on. If the problem continues, contact your Yaskawa representative or the nearest Yaskawa sales office.</li> </ul>
The drive is damaged	<ul style="list-style-type: none"> <li>• Check the drive output side short circuit for a broken output transistor B1 and U/T1, V/T2, W/T3 – and U/T1, V/T2, W/T3</li> <li>• Contact your Yaskawa representative or nearest Yaskawa sales office.</li> </ul>

HOA Keypad Display	Fault Name
SEr	Too Many Speed Search Restarts
	The number of Speed Search restarts exceeded the value set to b3-19.
<b>Cause</b>	<b>Possible Solution</b>
Parameters related to Speed Search are set to the wrong values	<ul style="list-style-type: none"> <li>• Reduce the detection compensation gain during Speed Search (b3-10).</li> <li>• Increase the current level when attempting Speed Search (b3-17).</li> <li>• Increase the detection time during Speed Search (b3-18).</li> <li>• Repeat Auto-Tuning.</li> </ul>
The motor is coasting in the opposite direction of the Run command	Set b3-14 to 1 to enable Bi-Directional Speed Search.

HOA Keypad Display	Fault Name
SPL Suction Pressure Loss	Suction Pressure Loss
	Wire-break detection for suction pressure.
<b>Cause</b>	<b>Possible Solution</b>
An analog input programmed for setting 23 “WaterLvl/Suction” has dropped below 3 mA or risen above 21 mA for longer than 1 second.	Repair pressure sensor or wiring.

HOA Keypad Display	Fault Name
TdE	Time Data Error
<b>Cause</b>	<b>Possible Solution</b>
An error has occurred in the Real-Clock Time function of the HOA keypad.	Replace the HOA keypad. For instructions on replacing the HOA keypad, contact Yaskawa or your nearest sales representative.

HOA Keypad Display	Fault Name
THo </>	Thermistor Disconnect
	The thermistor that detects motor temperature has become disconnected.
<b>Cause</b>	<b>Possible Solution</b>

HOA Keypad Display	Fault Name
The motor thermistor is not connected properly.	Check the thermistor wiring.

<1> Detected in models 4A0930 and 4A1200.

HOA Keypad Display	Fault Name
TIE	Time Interval Error
Cause	Possible Solution
An error has occurred in the Real-Clock Time function of the HOA keypad.	Replace the HOA keypad. For instructions on replacing the HOA keypad, contact Yaskawa or your nearest sales representative.

HOA Keypad Display	Fault Name
TIM	Time Not Set
Cause	Possible Solution
The Real-Time Clock for the HOA keypad is not set in parameter o4-17 and a feature that requires RTC information is enabled. <ul style="list-style-type: none"> <li>The drive is a new drive, first power-up condition</li> <li>o4-17 was set to 2, Reset, by the user, manually clearing the Real-Time Clock data.</li> </ul>	Set o4-17 to 1 to set the time for the HOA keypad. The drive will display the "Clock Not Set" alarm when the Real time Clock is not set. Additionally, at power up, if the "TIM" condition is present, the drive will automatically switch to the time setting screen (o4-17 = 1) for 30 seconds to prompt the user to set the Real-Time Clock.
The user did not set the Real Time Clock when prompted following power-up.	Cycle power to the drive and set the Real Time Clock within 30 seconds of power-up, or set the clock manually via parameter o4-17.
The HOA keypad battery is low or the battery has been replaced.	Replace the HOA keypad battery and set the Real-Time Clock.
An error has occurred in the Real-Time Clock function of the HOA keypad.	Replace the digital operator. For instructions on replacing the HOA keypad, contact Yaskawa or your nearest sales representative.

HOA Keypad Display	Fault Name
TLGI Geothermal Input	Temperature Lost Geothermal Input
	The geothermal input is not present.
Cause	Possible Solutions
The input signal level has dropped below 3 mA or risen above 21 mA when the drive was running and b1-01 = 5, H3-0□ = 21 (Geothermal Input), H3-0□ = 2 (4 to 20 mA), and Q2-09 = 2 (Fault).	Confirm that the device connected to the analog input terminal is installed and working properly.
The drive was running while b1-01 = 5, H3-0□ ≠ 21 (Geothermal Temp), and Q2-09 = 2 (Fault).	Assign one of the analog inputs to "Geothermal Temperature", H3-0□ = 21.

HOA Keypad Display	Fault Name
UL3	Undertorque Detection 1
	The current has fallen below the minimum value set for torque detection (L6-02) for longer than the allowable time (L6-03).
Cause	Possible Solution
Parameter settings are not appropriate for the load	Check the settings of parameters L6-02 and L6-03.
There is a fault on the machine side	Check the load for any problems.

HOA Keypad Display	Fault Name
UL4	Undertorque Detection 2
	The current has fallen below the minimum value set for torque detection (L6-05) for longer than the allowable time (L6-06).
Cause	Possible Solution
Parameter settings are not appropriate for the load	Check L6-05 and L6-06 settings
There is a fault on the machine side	Check the load for any problems.

## 5.2 Fault Detection

HOA Keypad Display	Fault Name
UL6	Motor Underload The load has fallen below the underload curve defined in L6-14.
<b>Cause</b>	<b>Possible Solution</b>
The output current has fallen below the motor underload curve defined in L6-14 for longer than the time set to L6-03	Adjust the value set to L6-14 so that output current remains above the motor underload curve during normal operation.

HOA Keypad Display	Fault Name
UnbC </>	Current Unbalance Current flow has become unbalanced.
<b>Cause</b>	<b>Possible Solution</b>
The internal current sensor has detected a current unbalance situation.	<ul style="list-style-type: none"> <li>• Check wiring</li> <li>• Check for damaged transistors.</li> <li>• Check for short circuits or grounding problems on the connected motor.</li> </ul>

<1> Detected in models 4A0930 and 4A1200.

HOA Keypad Display	Fault Name
Uv1	DC Bus Undervoltage One of the following conditions occurred while the drive was running: <ul style="list-style-type: none"> <li>• Voltage in the DC bus fell below the undervoltage detection level (L2-05).</li> <li>• For 200 V class drives: approximately 190 V</li> <li>• For 400 V class drives: approximately 380 V (350 V when E1-01 is less than 400)</li> <li>• For 600 V class drives: approximately 475 V</li> </ul> The fault is output only if L2-01 is set to 0 or 1 and the DC bus voltage has fallen below the level set to L2-05 for longer than the time set to L2-02.
<b>Cause</b>	<b>Possible Solution</b>
Input power phase loss	<ul style="list-style-type: none"> <li>• The main circuit drive input power is wired incorrectly.</li> <li>• Correct the wiring.</li> </ul>
One of the drive input power wiring terminals is loose	<ul style="list-style-type: none"> <li>• Ensure there are no loose terminals.</li> <li>• Apply the tightening torque specified in this manual to fasten the terminals. <i>Refer to Main Circuit Wire Gauges and Tightening Torques on page 110</i> for details.</li> </ul>
There is a problem with the voltage from the drive input power	<ul style="list-style-type: none"> <li>• Check the voltage.</li> <li>• Correct the voltage to be within the range listed in drive input power specifications.</li> <li>• If there is no problem with the power supply to the main circuit, check for problems with the main circuit magnetic contactor.</li> </ul>
The power has been interrupted	Correct the drive input power.
The main circuit capacitors are worn	<ul style="list-style-type: none"> <li>• Check the maintenance time for the capacitors (U4-05).</li> <li>• Replace either the control board or the entire drive if U4-05 exceeds 90%. For instructions on replacing the control board, contact Yaskawa or a Yaskawa representative.</li> </ul>
The relay or contactor on the soft-charge bypass circuit is damaged	<ul style="list-style-type: none"> <li>• Cycle power to the drive and see if the fault reoccurs.</li> <li>• If the problem continues, replace either the control board or the entire drive. For instructions on replacing the control board, contact Yaskawa or a Yaskawa representative.</li> <li>• Check monitor U4-06 for the performance life of the soft-charge bypass.</li> <li>• Replace either the control board or the entire drive if U4-06 exceeds 90%. For instructions on replacing the control board, contact Yaskawa or a Yaskawa representative.</li> </ul>

HOA Keypad Display	Fault Name
Uv2	Control Power Supply Voltage Fault Voltage is too low for the control drive input power.
<b>Cause</b>	<b>Possible Solution</b>
In drive models 2A0004 to 2A0056 or 4A0002 to 4A0031, L2-02 was changed from its default value without installing a Momentary Power Loss Ride-Thru unit	Correct the setting to L2-02 or install an optional Momentary Power Loss Ride-Thru unit.
Control power supply wiring is damaged	<ul style="list-style-type: none"> <li>• Cycle power to the drive. Check if the fault reoccurs.</li> <li>• If the problem continues, replace the control board, the entire drive, or the control power supply. For instructions on replacing the control board, contact Yaskawa or a Yaskawa representative.</li> </ul>

HOA Keypad Display	Fault Name
Internal circuitry is damaged	<ul style="list-style-type: none"> <li>• Cycle power to the drive. Check if the fault reoccurs.</li> <li>• If the problem continues, replace either the control board or the entire drive. For instructions on replacing the control board, contact Yaskawa or a Yaskawa representative.</li> </ul>

HOA Keypad Display	Fault Name
Uv3	Undervoltage 3 (Soft-Charge Bypass Circuit Fault)
	The soft-charge bypass circuit failed.
Cause	Possible Solution
The relay or contactor on the soft-charge bypass circuit is damaged	<ul style="list-style-type: none"> <li>• Cycle power to the drive and see if the fault reoccurs.</li> <li>• If the problem continues, replace either the control board or the entire drive. For instructions on replacing the control board, contact Yaskawa or a Yaskawa representative.</li> <li>• Check monitor U4-06 for the performance life of the soft-charge bypass.</li> <li>• Replace either the control board or the entire drive if U4-06 exceeds 90%. For instructions on replacing the control board, contact Yaskawa or a Yaskawa representative.</li> </ul>

HOA Keypad Display	Fault Name
Uv4 </>	Gate Drive Board Undervoltage
	Voltage drop in the gate drive board circuit
Cause	Possible Solution
Not enough power is being supplied to the gate drive board.	<ul style="list-style-type: none"> <li>• Cycle power to the drive and see if the fault reoccurs.</li> <li>• If the problem continues, replace either the gate drive board or the entire drive. For instructions on replacing the gate drive board, contact Yaskawa or a Yaskawa representative.</li> </ul>

<1> Detected in models 4A0930 and 4A1200.

HOA Keypad Display	Fault Name
VLTS	Volute-Thermostat Fault
Cause	Possible Solution
The digital input assigned to the volute/thermostat input (H1-0□ = 88 or 89) is active.	Check the wiring or wait for the volute or motor to cool.
Both volute/thermostat inputs are programmed simultaneously (H1-0□ = 88 and 89).	<ul style="list-style-type: none"> <li>• Program only one digital input to either H1-0□ = 88 or H1-0□ = 89.</li> <li>• Auto-restart of this fault is controlled by parameter L5-53, Volute-TStat Retry Selection.</li> </ul>

HOA Keypad Display	Fault Name
voF	Output Voltage Detection Fault
	Problem detected with the voltage on the output side of the drive.
Cause	Possible Solution
Hardware is damaged. Internal drive module MC / FAN overheat protection circuit board is due to abnormal ambient operating power.	<ul style="list-style-type: none"> <li>• Lower ambient temperature.</li> <li>• Replace the control board or the entire drive. For instructions on replacing the control board, contact Yaskawa or a Yaskawa representative.</li> </ul>

HOA Keypad Display	Fault Name
WLL Water Level Loss	Water Level Loss
Cause	Possible Solution
An analog input programmed for setting 23 "WaterLvl/Suction" has dropped below 3 mA or risen above 21 mA for longer than 1 second.	Repair level sensor or wiring.

## 5.3 Alarm Detection

### ◆ Alarm Codes, Causes, and Possible Solutions

Alarms are drive protection functions that do not necessarily cause the drive to stop. After removing the cause of an alarm, the drive will return to the same status it was before the alarm occurred.

When an alarm has been triggered, the ALM light on the HOA keypad display blinks and the alarm code display flashes. If a multi-function output is set for an alarm (H2-□□ = 10), that output terminal will be triggered.

**Note:** If a multi-function output is set to close when an alarm occurs (H2-□□ = 10), it will also close when maintenance periods are reached, triggering alarms LT-1 through LT-4 (triggered only if H2-□□ = 2F).

**Table 5.3 Alarm Codes, Causes, and Possible Solutions**

HOA Keypad Display	Minor Fault Name
ACCUM Accum Level	Accumulated Level Error
<b>Cause</b>	<b>Possible Solution</b>
The accumulated level has exceeded the values set in P6-11 to P6-14. This is only effective when P6-15, Accumulated Behavior is set to 1 (alarm).	Set the Accumulated Level fault characteristics in P6-11 to P6-14 and P6-16. Drive response to this condition is controlled by P6-15, Accumulated Behavior. Auto-restart of this fault is controlled by P6-15, Accumulated Behavior and P6-05, Flow Accumulation Reset.

HOA Keypad Display	Minor Fault Name
Accum Lvl Reached Cycle Run Cmd	Flow Accumulation level reached
<b>Cause</b>	<b>Possible Solution</b>
Accum Behavior P6-15 is set to 5 (Stop, Alarm, & Reset) and the Accumulated Level has been reached.	Cycle the Run command.

HOA Keypad Display	Minor Fault Name
AnalogFB Lost Switched to Net	Analog Feedback Lost
<b>Cause</b>	<b>Possible Solution</b>
Defective or broken analog input source.	Confirm that the PI feedback source is installed and working properly. If there is no feedback source, set P9-02 to 3 so the drive will read the network PI feedback from another drive.
H3-0□ is not set to B (PI Feedback)	Set H3-0□ to B if the analog input source is to be used for PI feedback. Set P9-02 to 3 if the drive does not have an analog PI feedback source.

HOA Keypad Display	Minor Fault Name
Anti-Jam Active	Anti-Jam Alarm
<b>Cause</b>	<b>Possible Solution</b>
The drive was not able to clear debris from the impeller in fewer than the attempts set in P7-02. This is only effective when P7-01, Anti-jam Operation is set to 1 (enabled).	<ul style="list-style-type: none"> <li>• Check for proper pump operation.</li> <li>• Set the Anti-jam fault characteristics in P7-02 to P7-08.</li> <li>• Drive response to this condition is controlled by P7-01, Anti-jam Operation Selection.</li> </ul>

HOA Keypad Display	Fault Name
AUXFB PI Aux Lvl Loss	Wire-break detection for PI Aux Feedback Level
<b>Cause</b>	<b>Possible Solution</b>
The analog input programmed for "PI Aux FB Level" (H3-□□ = 27) has dropped below 3 mA or risen above 21 mA for longer than 1 second.	Repair transducer or wiring.

HOA Keypad Display	Minor Fault Name
Backup FdBk Lost Check/Replace	Backup Feedback Device (H3-□□ = 24) lost.
<b>Cause</b>	<b>Possible Solution</b>

HOA Keypad Display	Minor Fault Name
Wire-break on Analog Input Terminal programmed for Backup PI Feedback (H3-□□ = 24)	Check the connection of the Backup Feedback transducer.
Backup PI Feedback Transducer is broken.	Replace Backup PI Feedback Transducer.
HOA Keypad Display	Minor Fault Name
bAT	Digital Operator Battery Voltage Low
Cause	Possible Solution
The digital operator battery is low	Replace the digital operator battery.
HOA Keypad Display	Minor Fault Name
bb	Baseblock
	Drive output interrupted as indicated by an external baseblock signal.
Cause	Possible Solution
External baseblock signal was entered via one of the multi-function input terminals (S1 to S8).	Check external sequence and baseblock signal input timing.
HOA Keypad Display	Minor Fault Name
boL	Braking Transistor Overload Fault
	The braking transistor in the drive has been overloaded.
Cause	Possible Solution
The proper braking resistor has not been installed.	Select the proper braking resistor.
HOA Keypad Display	Minor Fault Name
bUS	Option Communication Error
	<ul style="list-style-type: none"> <li>The connection was lost after initial communication was established.</li> <li>Assign a Run command frequency reference to the option.</li> </ul>
Cause	Possible Solution
Connection is broken or master controller stopped communicating.	<ul style="list-style-type: none"> <li>Check for faulty wiring.</li> <li>Correct the wiring.</li> <li>Check for disconnected cables and short circuits. Repair as needed.</li> </ul>
Option is damaged.	If there are no problems with the wiring and the fault continues to occur, replace the option.
The option is not properly connected to the drive.	<ul style="list-style-type: none"> <li>The connector pins on the option are not properly lined up with the connector pins on the drive.</li> <li>Reinstall the option.</li> </ul>
A data error occurred due to noise.	<ul style="list-style-type: none"> <li>Check options available to minimize the effects of noise.</li> <li>Take steps to counteract noise in the control circuit wiring, main circuit lines and ground wiring.</li> <li>Try to reduce noise on the controller side.</li> <li>Use surge absorbers on magnetic contactors or other equipment causing the disturbance.</li> <li>Use recommended cables or some other type of shielded line. Ground the shield to the controller side or on the input power side.</li> <li>Separate the wiring for communication devices from the drive input power lines. Install an EMC noise filter to the drive input power.</li> </ul>
HOA Keypad Display	Minor Fault Name
CALL	Serial Communication Transmission Error
	Communication has not yet been established.
Cause	Possible Solution
Communications wiring is faulty, there is a short circuit, or something is not connected properly.	<ul style="list-style-type: none"> <li>Check for wiring errors.</li> <li>Correct the wiring.</li> <li>Check for disconnected cables and short circuits. Repair as needed.</li> </ul>
Programming error on the master side.	Check communications at start-up and correct programming errors.
Communications circuitry is damaged.	<ul style="list-style-type: none"> <li>Perform a self-diagnostics check.</li> <li>If the problem continues, replace either the control board or the entire drive. For instructions on replacing the control board, contact Yaskawa or your nearest sales representative.</li> </ul>

### 5.3 Alarm Detection

HOA Keypad Display	Minor Fault Name
Termination resistor setting is incorrect.	Install a termination resistor at both ends of a communication line. Set the internal termination resistor switch correctly on slave drives. Place DIP switch S2 to the ON position.

HOA Keypad Display	Minor Fault Name
CE	MEMOBUS/Modbus Communication Error
	Control data was not received correctly for two seconds.
Cause	Possible Solution
A data error occurred due to noise.	<ul style="list-style-type: none"> <li>• Check options available to minimize the effects of noise.</li> <li>• Take steps to counteract noise in the control circuit wiring, main circuit lines, and ground wiring.</li> <li>• Reduce noise on the controller side.</li> <li>• Use surge absorbers for the magnetic contactors or other components that may be causing the disturbance.</li> <li>• Use only recommended shielded line. Ground the shield on the controller side or on the drive input power side.</li> <li>• Separate all wiring for communication devices from drive input power lines. Install an EMC noise filter to the drive input power supply.</li> </ul>
Communication protocol is incompatible.	<ul style="list-style-type: none"> <li>• Check the H5 parameter settings and the protocol setting in the controller.</li> <li>• Ensure settings are compatible.</li> </ul>
The CE detection time (H5-09) is set shorter than the time required for a communication cycle to take place.	<ul style="list-style-type: none"> <li>• Check the PLC.</li> <li>• Change the software settings in the PLC.</li> <li>• Set a longer CE detection time using parameter H5-09.</li> </ul>
Incompatible PLC software settings or there is a hardware problem.	<ul style="list-style-type: none"> <li>• Check the PLC.</li> <li>• Remove the cause of the error on the controller side.</li> </ul>
Communications cable is disconnected or damaged.	<ul style="list-style-type: none"> <li>• Check the connector to make sure the cable has a signal.</li> <li>• Replace the communications cable.</li> </ul>

HOA Keypad Display	Minor Fault Name
CE – Comm Loss Run at H5-14	MEMOBUS/Modbus Communicator Error. Drive runs at H5-14.
Cause	Possible Solution
A data error occurred due to noise.	<ul style="list-style-type: none"> <li>• Check options available to minimize the effects of noise.</li> <li>• Take steps to counteract noise in the control circuit wiring, main circuit lines, and ground wiring.</li> <li>• Reduce noise on the controller side.</li> <li>• Use surge absorbers for the magnetic contactors or other components that may be causing the disturbance.</li> <li>• Use only recommended shielded line. Ground the shield on the controller side or on the drive input power side.</li> <li>• Separate all wiring for communication devices from drive input power lines. Install an EMC noise filter to the drive input power supply.</li> </ul>
Communication protocol is incompatible.	<ul style="list-style-type: none"> <li>• Check the H5 parameter settings and the protocol setting in the controller.</li> <li>• Ensure settings are compatible.</li> </ul>
The CE detection time (H5-09) is set shorter than the time required for a communication cycle to take place.	<ul style="list-style-type: none"> <li>• Check the PLC.</li> <li>• Change the software setting in the PLC.</li> <li>• Set a longer CE detection time using parameter H5-09.</li> </ul>
Incompatible PLC software settings or there is a hardware problem.	<ul style="list-style-type: none"> <li>• Check the PLC.</li> <li>• Remove the cause of the error on the controller side.</li> </ul>
Communications cable is disconnected or damaged.	<ul style="list-style-type: none"> <li>• Check the connector to make sure the cable has a signal.</li> <li>• Replace the communications cable.</li> </ul>

HOA Keypad Display	Minor Fault Name
Current Limit Foldback	Current Limit Foldback
Cause	Possible Solution
Drive output speed is being limited due to the output current limit.	<ul style="list-style-type: none"> <li>• Reduce the load.</li> <li>• Verify setting of Q3-02.</li> <li>• Change to a larger drive size.</li> </ul>



HOA Keypad Display	Minor Fault Name
De-Scale/De-rag Active	De-scale is running
<b>Cause</b>	<b>Possible Solution</b>
De-scale is programmed and enough run-time has been accumulated.	If De-scale/De-rag is not desired, program P8-01 = 0 (Disabled). Adjust the De-scale Run Timer P8-08.

HOA Keypad Display	Minor Fault Name
Differential FB Detected	Differential Feedback Detected
<b>Cause</b>	<b>Possible Solution</b>
The difference between the PID Feedback and the Differential Feedback (H3-□□ = 28) exceeded the P4-18 level for the time set in P4-19.	<ul style="list-style-type: none"> <li>Replace the feedback transducer or transducers.</li> <li>Verify parameter settings P4-18 to P4-20.</li> </ul>

HOA Keypad Display	Minor Fault Name
dnE	Drive Disabled
<b>Cause</b>	<b>Possible Solution</b>
“Drive Enable” is set to a multi-function contact input (H1-□□ = 6A) and the contact is open.	Check the operation sequence.

HOA Keypad Display	Minor Fault Name
EF	Forward/Reverse Run Command Input Error
	Both forward run and reverse run closed simultaneously for longer than 0.5 s.
<b>Cause</b>	<b>Possible Solution</b>
Sequence error	Check the forward and reverse command sequence and correct the problem. <b>Note:</b> When minor fault EF detected, motor ramps to stop.

HOA Keypad Display	Minor Fault Name
EF0	Option Card External Fault
	An external fault condition is present.
<b>Cause</b>	<b>Possible Solution</b>
An external fault was received from the PLC with F6-03 set to 3, which allows the drive to continue running after an external fault occurs.	<ul style="list-style-type: none"> <li>Remove the cause of the external fault.</li> <li>Remove the external fault input from the PLC.</li> </ul>
There is a problem with the PLC program.	Check the PLC program and correct problems.

HOA Keypad Display	Minor Fault Name
EF1	Pump Fault (Input Terminal S1)
	External fault at multi-function input terminal S1.
EF2	Pump fault (input terminal S2)
	External fault at multi-function input terminal S2.
EF3	Pump fault (input terminal S3)
	External fault at multi-function input terminal S3.
EF4	Pump fault (input terminal S4)
	External fault at multi-function input terminal S4.
EF5	Pump fault (input terminal S5)
	External fault at multi-function input terminal S5.
EF6	Pump fault (input terminal S6)
	External fault at multi-function input terminal S6.
EF7	Pump fault (input terminal S7)
	External fault at multi-function input terminal S7.
EF8	Pump fault (input terminal S8)
	External fault at multi-function input terminal S8.

### 5.3 Alarm Detection

HOA Keypad Display	Minor Fault Name
Cause	Possible Solutions
An external device has tripped an alarm function.	Remove the cause of the external fault and reset the multi-function input value.
Wiring is incorrect.	<ul style="list-style-type: none"> <li>Ensure the signal lines have been connected properly to the terminals assigned for external fault detection (H1-□□ = 2C to 2F).</li> <li>Reconnect the signal line.</li> </ul>
Multi-function contact inputs are set incorrectly.	<ul style="list-style-type: none"> <li>Check if the unused terminals have been set for H1-□□ = 2C to 2F (External Fault).</li> <li>Change the terminal settings.</li> </ul>

HOA Keypad Display	Minor Fault Name
Cause	Possible Solution
EoF	Emergency Override Forward Run
The multi-function digital input for EmergOverrideFWD (H1-□□ = AF) has been closed.	Open H1-□□ = AF if the emergency condition is no longer present

HOA Keypad Display	Minor Fault Name
Cause	Possible Solution
Eor	Emergency Override Reverse Run
The multi-function digital input for EmergOverrideREV (H1-□□ = B0) has been closed.	Open H1-□□ = B0 if the emergency condition is no longer present

HOA Keypad Display	Fault Name
Cause	Possible Solution
E5	SI-T3 Watchdog Timer Error The watchdog timed out.
Data has not been received from the PLC	Execute DISCONNECT or ALM_CLR, then issue a CONNECT command or SYNC_SET command and proceed to phase 3. Refer to the SI-T3 Option Technical Manual for more details on troubleshooting.

HOA Keypad Display	Minor Fault Name
Cause	Possible Solution
FAn	Internal Fan Error Fan or magnetic contactor failure
Internal cooling fan has malfunctioned	<ul style="list-style-type: none"> <li>Cycle power to the drive.</li> <li>Check for fan operation.</li> <li>Verify the cumulative operation time of the fan with monitor U4-03, and verify the cumulative operation time of the fan maintenance timer with U4-04.</li> <li>If the cooling fan has exceeded its expected performance life or is damaged in any other way, follow the replacement instructions in the <i>Peripheral Devices &amp; Options</i> chapter.</li> </ul>
Fault detected in the internal cooling fan or magnetic contactor to the power supply.	<ul style="list-style-type: none"> <li>Cycle power to the drive.</li> <li>If the fault continues to occur, replace the power board/gate drive board or the entire drive.</li> <li>Contact Yaskawa or a Yaskawa representative for instructions on replacing the power board/gate drive board.</li> </ul>

HOA Keypad Display	Minor Fault Name
Cause	Possible Solutions
Feedback Loss Go To Freq. b5-13	PI Feedback Loss The drive will run at the speed set in b5-13, Feedback Loss Goto Frequency.
PI feedback source is incorrectly installed or is not working. Effective only when b5-12 is set to 3 (Run at b5-13).	<ul style="list-style-type: none"> <li>Confirm that the PID feedback source is installed and working properly.</li> <li>Drive response to this condition is controlled by b5-12, Feedback Loss 4 to 20 mA Detection Selection, and b5-13, Feedback Loss Go To Frequency.</li> </ul>

HOA Keypad Display	Minor Fault Name
Cause	Possible Solutions
Feedback Loss Wire Break	PI Feedback Loss The analog input programmed for PID feedback has gone above 21 mA or fallen below 3 mA.

HOA Keypad Display	Minor Fault Name
PI feedback source is incorrectly installed or is not working. This is effective only when b5-12 Feedback Loss 4 to 20 mA Detection Selection is set to 1 (alarm).	<ul style="list-style-type: none"> <li>Confirm that the PID feedback source is installed and working properly.</li> <li>Drive response to this condition is controlled by b5-12, Feedback Loss 4 to 20 mA Detection Selection, and b5-13, Feedback Loss Go To Frequency.</li> <li>Auto-restart of this fault is controlled by L5-42, Feedback Loss Fault Retry Selection.</li> </ul>

HOA Keypad Display	Minor Fault Name
Freq. Ref Pump Min (P1-06)	Minimum Pump Frequency Reference
	Drive frequency reference is set lower than P1-06, Minimum Pump Frequency.
Cause	Possible Solutions
The frequency reference is set lower than P1-06. The frequency reference is internally set to the P1-06 value during this time. This will only be active when the following conditions are true: <ul style="list-style-type: none"> <li>Drive is NOT in PI Mode</li> <li>Minimum Pump Frequency is enabled (P1-06 &gt; 0.00)</li> </ul>	Increase the frequency reference to a value greater than P1-06.

HOA Keypad Display	Minor Fault Name
Freq. Ref Thrust (P4-12)	Thrust Frequency Reference
	The fixed frequency reference is set to a value lower than the P4-12, Thrust Frequency, setting.
Cause	Possible Solutions
The frequency reference is set lower than P4-12. The frequency reference is internally set to the P4-12 value during this time. This will only be active when the following conditions are true: <ul style="list-style-type: none"> <li>Drive is NOT in PI Mode</li> <li>Thrust bearing is enabled (P4-12 &gt; 0.00)</li> </ul>	Increase the frequency reference to a value greater than P4-12.

HOA Keypad Display	Minor Fault Name
Geo Params Chk Q2-05 to Q2-08	Geothermal Mode Parameters
	The drive is running at the level set in Q2-03 due to an incorrect setting.
Cause	Possible Solutions
The temperature parameter values are set incorrectly.	Set the temperature parameters in the following order: Q2-08 > Q2-07 > Q2-06 > Q2-05

HOA Keypad Display	Minor Fault Name
HCA	Current Alarm
	Drive current exceeded overcurrent warning level (150% of the rated current).
Cause	Possible Solutions
Load is too heavy.	Reduce the load for applications with repetitive operations (i.e., stops and starts), or replace the drive.
Acceleration and deceleration times are too short.	<ul style="list-style-type: none"> <li>Calculate the torque required during acceleration and for the inertia moment.</li> <li>If the torque level is not right for the load, take the following steps: <ul style="list-style-type: none"> <li>Increase the acceleration and deceleration times (C1-01 through C1-04).</li> <li>Increase the capacity of the drive.</li> </ul> </li> </ul>
A special-purpose motor is being used, or the drive is attempting to run a motor greater than the maximum allowable capacity.	<ul style="list-style-type: none"> <li>Check the motor capacity.</li> <li>Use a motor appropriate for the drive. Ensure the motor is within the allowable capacity range.</li> </ul>
The current level increased due to Speed Search after a momentary power loss or while attempting to perform a fault restart.	The alarm will only appear briefly. There is no need to take action to prevent the alarm from occurring in such instances.

HOA Keypad Display	Fault Name
HIAUX High PI Aux Lvl	High PI Auxiliary Feedback Level
Cause	Possible Solution

### 5.3 Alarm Detection

HOA Keypad Display	Fault Name
PI Aux Feedback has risen above the Q6-12 level for longer than the time set in Q6-13 and the drive is running in AUTO, and output frequency is greater than zero.	<ul style="list-style-type: none"> <li>Lower the PI Aux Feedback level</li> <li>Adjust parameters Q6-12 and Q6-13.</li> </ul>

HOA Keypad Display	Minor Fault Name
HIFLO High Flow	High Flow Error The meter has detected a high flow condition.
Cause	Possible Solution
The flow is too high	Reduce the flow
The measured water flow has risen above the P6-17 level for the time set in P6-18. This is only effective when P6-19, High Flow Select is set to 1 (alarm).	<ul style="list-style-type: none"> <li>Set the High Flow fault characteristics in P6-17 and P6-18.</li> <li>Drive response to this condition is controlled by P6-19, High Flow Select.</li> <li>Auto-restart of this fault is controlled by P6-19, High Flow Select.</li> </ul>

HOA Keypad Display	Minor Fault Name
High Feedback High FB Sensed	High Feedback Level Alarm The feedback signal is too high.
Cause	Possible Solutions
The feedback level has risen above the level set in P1-11, High Feedback Level. This is only effective when P1-13, High Feedback Selection, is set to 1 (Alarm and digital out).	<ul style="list-style-type: none"> <li>Decrease the feedback signal.</li> <li>Set the High Feedback alarm characteristics in P1-11 and P-12.</li> <li>Drive response to this condition is controlled by P1-13, High Feedback Selection.</li> </ul>

HOA Keypad Display	Minor Fault Name
HISUC High Suction	High Section Pressure
Cause	Possible Solution
The suction pressure has risen above the level set in Q5-12. This is only effective when Q5-14, High Suction Pressure Behavior Select is set to 1 (alarm).	<ul style="list-style-type: none"> <li>Reduce the system pressure.</li> <li>Set the High Suction Pressure alarm characteristics in Q5-12.</li> <li>Drive response to this condition is controlled by Q5-14, High Suction Pressure Behavior Select.</li> <li>Auto-restart of this fault is controlled by Q5-14, High Suction Pressure Behavior Select and Q5-15, Suction Pressure Auto-restart Time.</li> </ul>

HOA Keypad Display	Fault Name
LOAUX Low PI Aux Lvl	Low PI Auxiliary Feedback Level
Cause	Possible Solution
PI Aux Feedback has fallen below the Q6-09 level for longer than the time set in Q6-10 and the drive is running in HAND or AUTO.	<ul style="list-style-type: none"> <li>Raise the PI Aux Feedback level</li> <li>Adjust parameters Q6-09 and Q6-10.</li> </ul>

HOA Keypad Display	Minor Fault Name
LOP	Loss of Prime The pump has lost its prime and P1-22 is set to 1.
Cause	Possible Solution
The measured quantity of water has dropped below the level set in P1-19, Prime Loss Level, for the time set in P1-20, Loss of Prime Time, and the output frequency has risen above P1-21, Prime Loss Frequency. This could be due to a dry well, air in the system, or no water in the system. This is effective only when P1-22 Loss of Prime Selection is set to 1 (alarm).	<ul style="list-style-type: none"> <li>If there is resistance in the pump, allow the system to pump water again.</li> <li>Set the Loss of Prime alarm characteristics in P1-18, P1-19, P1-20, and P1-21.</li> <li>Drive response to this condition is controlled by P1-21, Loss of Prime Selection.</li> </ul>

HOA Keypad Display	Minor Fault Name
LOSUC Low Suction	Low Section Pressure
Cause	Possible Solution

HOA Keypad Display	Minor Fault Name
The suction pressure has fallen below the level set in Q5-09 for longer than the time set in Q5-10. This is only effective when Q5-11, Low Suction Pressure Behavior Select is set to 1 (alarm).	<ul style="list-style-type: none"> <li>• Increase the system pressure.</li> <li>• Set the Low Suction alarm characteristics in Q5-09, Q5-10, and Q5-18. Q5-10 Detection Delay Time only applies if Q5-01 = 2.</li> <li>• Drive response to this condition is controlled by Q5-11, Low Suction Pressure Behavior Select.</li> </ul>
HOA Keypad Display	Minor Fault Name
Low City Pressure	Low City Pressure
Cause	Possible Solution
Insufficient pressure is present on the inlet to the pump. Shown when P4-24 = 0 and when the digital input has been active (closed for P4-21 = 0, or open for P4-21 = 1) for the time set in P4-22.	<ul style="list-style-type: none"> <li>• Check pressure switch contact for correct operation.</li> <li>• Check control wiring to drive terminal strip from pressure switch contact.</li> <li>• Check to make sure that suction pressure is present by means of a separate measuring device.</li> </ul>
HOA Keypad Display	Minor Fault Name
Low Feedback Low FB Sensed	Low Feedback Level Alarm
	The feedback signal is too low.
Cause	Possible Solutions
The feedback level has dropped below the level set in P1-08, Low Feedback Level. This is only effective when P1-10, Low Feedback Selection, is set to 1 (Alarm and digital out).	<ul style="list-style-type: none"> <li>• Increase the feedback signal.</li> <li>• Set the Low Feedback alarm characteristics in P1-08 and P1-09.</li> <li>• Drive response to this condition is controlled by P1-10, Low Feedback Selection.</li> </ul>
HOA Keypad Display	Minor Fault Name
Low Suction Pressure	Low Suction Pressure
Cause	Possible Solution
Insufficient suction pressure is present. Shown when P4-24 = 1 and when the digital input has been active (closed for P4-21 = 0, or open for P4-21 = 1) for the time set in P4-22.	<ul style="list-style-type: none"> <li>• Check pressure switch contact for correct operation.</li> <li>• Check control wiring to drive terminal strip from pressure switch contact.</li> <li>• Check to make sure that suction pressure is present by means of a separate measuring device.</li> <li>• <b>Note:</b> The following possible solutions apply to drive software versions PRG: 8551 and earlier.</li> <li>• Increase the system pressure.</li> <li>• Set the Low Suction alarm characteristics in Q5-09 and Q5-18.</li> <li>• Drive response to this condition is controlled by Q5-11, Low Suction Pressure Behavior Select.</li> </ul>
HOA Keypad Display	Minor Fault Name
Low Water in Tank	Low Water in Tank
Cause	Possible Solution
Insufficient pressure is present on the inlet to the pump. Shown when P4-24 = 2 and when the digital input has been active (closed for P4-21 = 0, or open for P4-21 = 1) for the time set in P4-22.	<ul style="list-style-type: none"> <li>• Check pressure switch contact for correct operation.</li> <li>• Check control wiring to drive terminal strip from pressure switch contact.</li> <li>• Check to make sure that suction pressure is present by means of a separate measuring device.</li> <li>• Raise the water level.</li> <li>• Set the Low Water Level alarm characteristics in Q4-09.</li> <li>• Drive response to this condition is controlled by Q4-11, Low Level Behavior.</li> </ul>
HOA Keypad Display	Fault Name
Low WL/SP/PI-Aux Drive Disabled	Low Water Level / Suction Pressure / Aux PI Feedback Disabled
	Water Level or Suction Pressure is below the Q4-06/Q5-06/Q6-06 setting.
Cause	Possible Solution
Drive is not allowed to run in MEMOBUS multiplex when P9-51 is set to 1, the Water Level or Suction Pressure is below the Q4-06/Q5-06/Q6-06 setting, and the drive is stopped or running as a lag drive.	<ul style="list-style-type: none"> <li>• Confirm that the Water Level, Suction Pressure, or Aux PI Feedback source is installed and working properly.</li> <li>• Wait for the WL/SP/PIAuxFB to recover.</li> </ul>

### 5.3 Alarm Detection

HOA Keypad Display	Minor Fault Name
LT-1	Cooling Fan Maintenance Time
	The cooling fan has reached its expected maintenance period and may need to be replaced. <b>Note:</b> An alarm output (H2-□□ = 10) will only be triggered if both (H2-□□ = 2F and H2-□□ = 10) are set.
<b>Cause</b>	<b>Possible Solution</b>
The cooling fan has reached 90% of its expected performance life.	Replace the cooling fan and set o4-03 to 0 to reset the Maintenance Monitor.

HOA Keypad Display	Minor Fault Name
LT-2	Capacitor Maintenance Time
	The main circuit and control circuit capacitors are nearing the end of their expected performance life. <b>Note:</b> An alarm output (H2-□□ = 10) will only be triggered if H2-□□ = 2F.
<b>Cause</b>	<b>Possible Solution</b>
The main circuit and control circuit capacitors have reached 90% of their expected performance lives.	Replace either the control board or the entire drive. For instructions on replacing the control board, contact Yaskawa or your nearest sales representative.

HOA Keypad Display	Minor Fault Name
LT-3	Soft Charge Bypass Relay Maintenance Time
	The DC bus soft charge relay is nearing the end of its expected performance life. <b>Note:</b> An alarm output (H2-□□ = 10) will only be triggered if H2-□□ = 2F.
<b>Cause</b>	<b>Possible Solution</b>
The DC bus soft charge relay has reached 90% of expected performance life.	Replace either the control board or the entire drive. For instructions on replacing the control board, contact Yaskawa or your nearest sales representative.

HOA Keypad Display	Minor Fault Name
LT-4	IGBT Maintenance Time (50%)
	IGBTs have reached 50% of their expected performance life. <b>Note:</b> An alarm output (H2-□□ = 10) will only be triggered if H2-□□ = 2F.
<b>Cause</b>	<b>Possible Solution</b>
IGBTs have reached 50% of their expected performance life.	Check the load, carrier frequency, and output frequency.

HOA Keypad Display	Minor Fault Name
Main FdBk Lost Using Backup FB	Main Feedback Device (H3-□□ = B) lost.
<b>Cause</b>	<b>Possible Solution</b>
Wire-break on Analog Input Terminal programmed for Primary PI Feedback (H3-□□ = B)	Check the connection of the Main Feedback transducer.
Main PI Feedback Transducer is broken.	Replace Main PI Feedback Transducer.

HOA Keypad Display	Minor Fault Name
Net Flow Meter Lost, Chk Source	Net Flow Meter Loss
	There is no drive on the MEMOBUS network with an analog flow meter.
<b>Cause</b>	<b>Possible Solution</b>
When P1-01 = 3, P6-01 > 0, and P9-40 = 3, the flow meter function has not received a valid flow rate from another drive that is also running the flow meter function.	<ul style="list-style-type: none"> <li>Set P9-40 to 0 if the drive has an operational flow meter connected to an analog or pulse input terminal.</li> <li>If another drive on the MEMOBUS network has a flow meter connected to an analog or pulse input terminal, confirm that drive is online with parameter settings P6-01 &gt; 0 and P9-40 = 0.</li> </ul>

HOA Keypad Display	Minor Fault Name
NETSCAN Waiting for Master	NETSCAN
	Drive is waiting for a message from the master.
<b>Cause</b>	<b>Possible Solution</b>

HOA Keypad Display	Minor Fault Name
No message was received from the master within the time set in P9-28.	<ul style="list-style-type: none"> <li>• Increase the P9-26 setting to account for network latency.</li> <li>• Verify that there is a drive on the network with parameter P1-01 set to 3 and P9-27 to 0.</li> <li>• Check network connections and verify H5-01 and P9-25 settings for all drives on the network.</li> </ul>

HOA Keypad Display	Minor Fault Name
NMS	Not Maintaining Setpoint
	The setpoint cannot be maintained and P1-17 is set to 1.
<b>Cause</b>	<b>Possible Solution</b>
When the feedback deviates from the setpoint at a level greater than P1-15, for a time set in P1-16. This is effective only when P1-17 is set to 1 (alarm).	<ul style="list-style-type: none"> <li>• Check for a blocked impeller, over cycling, or broken pipe.</li> <li>• Set the Not Maintaining Setpoint alarm characteristics in P1-16 and P1-17.</li> <li>• Drive response to this condition is controlled by P1-17, Not Maintaining Setpoint Selection.</li> </ul>

HOA Keypad Display	Minor Fault Name
oH	Heatsink Overheat
	The temperature of the heatsink exceeded the overheat pre-alarm level set to L8-02.
<b>Cause</b>	<b>Possible Solution</b>
Surrounding temperature is too high	<ul style="list-style-type: none"> <li>• Check the surrounding temperature.</li> <li>• Improve the air circulation within the enclosure panel.</li> <li>• Install a fan or air conditioner to cool surrounding area.</li> <li>• Remove anything near drive that may cause extra heat.</li> </ul>
Internal cooling fan has stopped.	<ul style="list-style-type: none"> <li>• Replace the cooling fan.</li> <li>• After replacing the drive, set parameter o4-03 to 0 to reset the cooling fan operation time.</li> </ul>
Airflow around the drive is restricted.	<ul style="list-style-type: none"> <li>• Provide proper installation space around the drive as indicated in the manual. <i>Refer to Installation Orientation and Spacing on page 36</i> for details.</li> <li>• Allow for the proper space and ensure that there is sufficient circulation around the control panel.</li> <li>• Check for dust or other foreign materials clogging the cooling fan.</li> <li>• Clear debris caught in the fan that restricts air circulation.</li> </ul>

HOA Keypad Display	Minor Fault Name
oH2	Drive Overheat Warning
	“Drive Overheat Warning” was input to a multi-function input terminal, S1 through S8 (H1-□□= B).
<b>Cause</b>	<b>Possible Solution</b>
An external device triggered an overheat warning in the drive.	Search for the device that tripped the overheat warning. Remove the cause of the problem.

HOA Keypad Display	Minor Fault Name
oH3	Motor Overheat
	The motor overheat signal entered to a multi-function analog input terminal exceeded the alarm level (H3-02, H3-06 or H3-10 = E).
<b>Cause</b>	<b>Possible Solutions</b>
Motor thermostat wiring is faulty (PTC input).	Repair the PTC input wiring.
There is a fault on the machine side (e.g., the machine is locked up).	<ul style="list-style-type: none"> <li>• Check the status of the machine.</li> <li>• Remove the cause of the fault.</li> </ul>
Motor has overheated.	<ul style="list-style-type: none"> <li>• Check the load size, accel/decel times, and cycle times.</li> <li>• Decrease the load.</li> <li>• Increase accel and decel times (C1-01 to C1-04).</li> <li>• Adjust the preset V/f pattern (E1-04 through E1-10). This involves reducing E1-08 and E1-10. <ul style="list-style-type: none"> <li><b>Note:</b> Refrain from lowering E1-08 and E1-10 excessively to prevent a reduction in load tolerance at low speeds.</li> </ul> </li> <li>• Check the motor-rated current.</li> <li>• Enter motor-rated current on motor nameplate (E2-01).</li> <li>• Ensure the motor cooling system is operating normally.</li> <li>• Repair or replace the motor cooling system.</li> </ul>

### 5.3 Alarm Detection

HOA Keypad Display	Minor Fault Name
oH5 <1>	Motor Overheat (NTC Input)
	The motor temperature exceeded the level set to L1-16 (or L1-18 for motor 2)
Cause	Possible Solutions
Motor has overheated.	<ul style="list-style-type: none"> <li>Reduce the load.</li> <li>Check the ambient temperature.</li> </ul>

<1> Detected in models 4A0930 and 4A1200.

HOA Keypad Display	Minor Fault Name
oL1	Motor Overload
	The electronic motor overload protection tripped
Cause	Possible Solution
Load is too heavy	Reduce the load.
Cycle times are too short during acceleration and deceleration	Increase the acceleration and deceleration times (C1-01 through C1-04).
A general-purpose motor is driven below the rated speed with a high load	<ul style="list-style-type: none"> <li>Reduce the load.</li> <li>Increase the speed.</li> <li>If the motor is supposed to operate at low speeds, either increase the motor capacity or use a motor specifically designed to operate in the desired speed range.</li> </ul>
The output voltage is too high	<ul style="list-style-type: none"> <li>Adjust the user-set V/f pattern (E1-04 through E1-10) by reducing E1-08 and E1-10.</li> <li>Do not set E1-08 and E1-10 too low. This reduces load tolerance at low speeds.</li> </ul>
The wrong motor rated current is set to E2-01	<ul style="list-style-type: none"> <li>Check the motor-rated current.</li> <li>Enter the motor rated current to parameter E2-01 as indicated on the motor nameplate.</li> </ul>
The base frequency is set incorrectly	<ul style="list-style-type: none"> <li>Check the rated frequency indicated on the motor nameplate.</li> <li>Enter the rated frequency to E1-06 (Base Frequency).</li> </ul>
The electrical thermal protection characteristics and motor overload characteristics do not match	<ul style="list-style-type: none"> <li>Check the motor characteristics.</li> <li>Correct the type of motor protection that has been selected (L1-01).</li> <li>Install an external thermal relay.</li> </ul>
The electrical thermal relay is operating at the wrong level	<ul style="list-style-type: none"> <li>Check the current rating listed on the motor nameplate.</li> <li>Check the value set for the motor rated current (E2-01).</li> </ul>
Motor overheated by overexcitation operation	<ul style="list-style-type: none"> <li>Overexcitation increases the motor loss and the motor temperature. Excessive duration of overexcitation may cause motor damage. Prevent excessive overexcitation operation or apply proper cooling to the motor.</li> <li>Reduce the excitation deceleration gain (n3-13).</li> <li>Set L3-04 (Stall Prevention during Deceleration) to a value other than 4.</li> </ul>
Parameters related to Speed Search are set incorrectly	<ul style="list-style-type: none"> <li>Check values set to Speed Search related parameters.</li> <li>Adjust the Speed Search current and Speed Search deceleration times (b3-02 and b3-03 respectively).</li> <li>After Auto-Tuning, set b3-24 to 1 to enable Speed Estimation Speed Search.</li> </ul>
Output current fluctuation due to power supply loss	Check the power supply for phase loss.

HOA Keypad Display	Minor Fault Name
oL2	Drive Overload
	The thermal sensor of the drive triggered overload protection.
Cause	Possible Solution
Load is too heavy	Reduce the load.
Acceleration or deceleration time is too short	Increase the settings for the acceleration and deceleration times (C1-01 through C1-04).
The output voltage is too high	<ul style="list-style-type: none"> <li>Adjust the preset V/f pattern (E1-04 through E1-10) by reducing E1-08 and E1-10.</li> <li>Do not lower E1-08 and E1-10 excessively. This reduces load tolerance at low speeds.</li> </ul>
Drive capacity is too small	Replace the drive with a larger model.
Overload occurred when operating at low speeds	<ul style="list-style-type: none"> <li>Reduce the load when operating at low speeds.</li> <li>Replace the drive with a model that is one frame size larger.</li> <li>Lower the carrier frequency (C6-02).</li> </ul>
Excessive torque compensation	Reduce the torque compensation gain in parameter C4-01 until there is less current but no speed loss.



HOA Keypad Display	Minor Fault Name
Parameters related to Speed Search are set incorrectly	<ul style="list-style-type: none"> <li>Check the settings for all Speed Search related parameters.</li> <li>Adjust the current used during Speed Search (b3-03) and the Speed Search deceleration time (b3-02).</li> <li>After Auto-Tuning, set b3-24 to 1 to enable Speed Estimation Speed Search.</li> </ul>
Output current fluctuation due to input phase loss	Check the power supply for phase loss.

HOA Keypad Display	Minor Fault Name
oL3	Overtorque Detection 1
	The current has exceeded the value set for torque detection (L6-02) for longer than the allowable time (L6-03).
<b>Cause</b>	<b>Possible Solution</b>
Parameter settings are not appropriate for the load	Check L6-02 and L6-03 settings.
Fault on the machine side (e.g., machine is locked up)	Check the status of the load. Remove the cause of the fault.

HOA Keypad Display	Minor Fault Name
oL4	Overtorque Detection 2
	The current has exceeded the value set for Overtorque Detection 2 (L6-05) for longer than the allowable time (L6-06).
<b>Cause</b>	<b>Possible Solution</b>
Parameter settings are not appropriate for the load	Check the settings of parameters L6-05 and L6-06.

HOA Keypad Display	Minor Fault Name
ov	DC Bus Overvoltage
	<p>The DC bus voltage exceeded the trip point.</p> <ul style="list-style-type: none"> <li>For 200 V class drives: approximately 410 V</li> <li>For 400 V class drives: approximately 820 V (740 V when E1-01 is less than 400)</li> <li>For 600 V class drives: approximately 1040 V</li> </ul>
<b>Cause</b>	<b>Possible Solutions</b>
Surge voltage present in the drive input power.	<ul style="list-style-type: none"> <li>Install a DC link choke or an AC reactor.</li> <li>Voltage surge can result from a thyristor convertor and a phase advancing capacitor operating on the same drive input power system.</li> </ul>
The motor is short-circuited.	<ul style="list-style-type: none"> <li>Check the motor power cable, relay terminals and motor terminal box for short circuits.</li> <li>Correct grounding shorts and turn the power back on.</li> </ul>
Ground current has overcharged the main circuit capacitors via the drive input power.	
Noise interference causes the drive to operate incorrectly.	<ul style="list-style-type: none"> <li>Review possible solutions for handling noise interference.</li> <li>Review section on handling noise interference and check control circuit lines, main circuit lines and ground wiring.</li> <li>If the magnetic contactor is identified as a source of noise, install a surge protector to the MC coil.</li> </ul>

HOA Keypad Display	Minor Fault Name
PoC	Pump Over Cycle
<b>Cause</b>	<b>Possible Solution</b>
The pump has exceeded the number of cycles set in P2-10 in the time set in P2-11 and P2-12 is set to 1 (alarm).	<ul style="list-style-type: none"> <li>Set the Pump Over Cycle alarm characteristics in P2-10 and P2-11.</li> <li>Drive response to this condition is controlled by P2-12, Over Cycling Mode.</li> </ul>

HOA Keypad Display	Minor Fault Name
R-DNE-S□	Remote Drive Disable
<b>Cause</b>	<b>Possible Solution</b>
Terminal S□ (H1-0□ = 95) has been closed for the time set in P4-26, Remote Drive Disable On-Delay, when P4-25, Remote Drive Disable Selection, was set to 0 (N.O.).	Remove conditions causing the terminal to close.

### 5.3 Alarm Detection

HOA Keypad Display	Minor Fault Name
Terminal S□ (H1-0□ = 95) has been open for the time set in P4-26, Remote Drive Disable On-Delay, when P4-25, Remote Drive Disable Selection, was set to 1 (N.C.).	Remove conditions causing the terminal to open.

HOA Keypad Display	Minor Fault Name
rUn	Motor Switch during Run
	A command to switch motors was entered during run.
Cause	Possible Solution
A motor switch command was entered during run.	Change the operation pattern so that the motor switch command is entered while the drive is stopped.

HOA Keypad Display	Minor Fault Name
SE	MEMOBUS/Modbus Communication Test Mode Error
	<b>Note:</b> This alarm will not trigger a multi-function output terminal that is set for alarm output (H2-□□ = 10).
Cause	Possible Solution
A digital input set to 67H (MEMOBUS/Modbus test) was closed while the drive was running.	Stop the drive and run the test again.

HOA Keypad Display	Minor Fault Name
SPL Suction Pressure Loss	Suction Pressure Loss
	Wire-break detection for suction pressure.
Cause	Possible Solution
An analog input programmed for setting 23 “WaterLvl/Suction” has dropped below 3 mA or risen above 21 mA for longer than 1 second.	Repair pressure sensor or wiring.

Digital Operator Display	Minor Fault Name
THo </>	Thermistor Disconnect
	The thermistor used to detect motor temperature has become disconnected.
Cause	Possible Solutions
The motor thermistor is not connected properly.	Check the thermistor wiring.

<1> Detected in models 4A0930 and 4A1200.

HOA Keypad Display	Minor Fault Name
TrPC	IGBT Maintenance Time (90%)
	IGBTs have reached 90% of their expected performance life.
Cause	Possible Solution
IGBTs have reached 90% of their expected performance life.	Replace the drive.

HOA Keypad Display	Minor Fault Name
UL3	Undertorque Detection 1
	The current has fallen below the minimum value set for torque detection (L6-02) for longer than the allowable time (L6-03).
Cause	Possible Solution
Parameter settings are not appropriate for the load	Check the settings of parameters L6-02 and L6-03.
There is a fault on the machine side	Check the load for any problems.

HOA Keypad Display	Minor Fault Name
UL4	Undertorque Detection 2
	The current has fallen below the minimum value set for torque detection (L6-05) for longer than the allowable time (L6-06).

HOA Keypad Display	Minor Fault Name
<b>Cause</b>	<b>Possible Solution</b>
Parameter settings are not appropriate for the load	Check L6-05 and L6-06 settings
There is a fault on the machine side	Check the load for any problems.

HOA Keypad Display	Minor Fault Name
UL6	Motor Underload The load has fallen below the underload curve defined in L6-14.
<b>Cause</b>	<b>Possible Solution</b>
The output current has fallen below the motor underload curve defined in L6-14 for longer than the time set to L6-03	Adjust the value set to L6-14 so that output current remains above the motor underload curve during normal operation.

HOA Keypad Display	Minor Fault Name
Uv	Undervoltage One of the following conditions was true when the drive was stopped and a Run command was entered: <ul style="list-style-type: none"> <li>DC bus voltage dropped below the level specified in L2-05.</li> <li>Contactor to suppress inrush current in the drive was opened.</li> <li>Low voltage in the control drive input power. This alarm outputs only if L2-01 is not 0 and DC bus voltage is under L2-05.</li> </ul>
<b>Cause</b>	<b>Possible Solution</b>
Phase loss in the drive input power.	Check for wiring errors in the main circuit drive input power. Correct the wiring.
Loose wiring in the drive input power terminals.	<ul style="list-style-type: none"> <li>Ensure the terminals have been properly tightened.</li> <li>Apply the tightening torque to the terminals as specified. <i>Refer to Main Circuit Wire Gauges and Tightening Torques on page 110.</i></li> </ul>
There is a problem with the drive input power voltage.	<ul style="list-style-type: none"> <li>Check the voltage.</li> <li>Lower the voltage of the drive input power so that it is within the limits listed in the specifications.</li> </ul>
Drive internal circuitry is worn.	<ul style="list-style-type: none"> <li>Check the maintenance time for the capacitors (U4-05).</li> <li>Replace either the control board or the entire drive if U4-05 exceeds 90%. For instructions on replacing the control board, contact Yaskawa or your nearest sales representative.</li> </ul>
The drive input power transformer is too small and voltage drops when the power is switched on.	<ul style="list-style-type: none"> <li>Check for an alarm when the magnetic contactor, line breaker, and leakage breaker are closed.</li> <li>Check the capacity of the drive input power transformer.</li> </ul>
Air inside the drive is too hot.	Check the temperature inside the drive.
The CHARGE light is broken or disconnected.	Replace either the control board or the entire drive. For instructions on replacing the control board, contact Yaskawa or your nearest sales representative.

HOA Keypad Display	Minor Fault Name
voF	Output Voltage Detection Error Problem detected with the voltage on the output side of the drive.
<b>Cause</b>	<b>Possible Solution</b>
Hardware is damaged. Internal drive module MC / FAN overheat protection circuit board is due to abnormal ambient operating power.	<ul style="list-style-type: none"> <li>Lower ambient temperature.</li> <li>Replace the control board or the entire drive. For instructions on replacing the control board, contact Yaskawa or a Yaskawa representative.</li> </ul>

HOA Keypad Display	Minor Fault Name
WLL Water Level Loss	Water Level Loss
<b>Cause</b>	<b>Possible Solution</b>
An analog input programmed for setting 23 "WaterLvl/Suction" has dropped below 3 mA or risen above 21 mA for longer than 1 second.	Repair level sensor or wiring.

### 5.3 Alarm Detection

HOA Keypad Display	Minor Fault Name
WL/SP/PIAux Lost Switched to Net	Analog Water Level / Suction Pressure / Aux PI Feedback Lost  Network Water Level / Suction Pressure / Aux PI Feedback is now being used because a wire-break was detected with the analog signal. Water Level Analog Input Wire Break (WL Wire Break) is effective when Q4-16 is set to 1 (Alarm) or 2 (Fault). Suction Pressure Analog Input Wire Break (SP Wire Break) is effective when Q5-19 is set to 1 (Alarm) or 2 (Fault).
<b>Cause</b>	<b>Possible Solution</b>
<ul style="list-style-type: none"> <li>Defective or broken analog input source.</li> <li>Wire-break detected with the Water Level / Suction Pressure analog signal (H3-□□ = 23).</li> <li>Wire-break detected with the PI Aux FB Level analog signal (H3-□□ = 27).</li> </ul>	<ul style="list-style-type: none"> <li>Confirm that the Water Level, Suction Pressure, or Aux PI Feedback source is installed and working properly.</li> <li>Confirm that the Q4-16, Q5-19, or Q6-19 settings are correct.</li> <li>Set P9-50 to 3 if the drive does not have an analog input source.</li> </ul>

HOA Keypad Display	Minor Fault Name
WrUn	Waiting for Run
<b>Cause</b>	<b>Possible Solutions</b>
The Run command has been applied and the b1-11 Back Spin Timer is active.	Adjust Back Spin Timer b1-11 to the desired delay time. The drive will start normally after the b1-11 timer expires.

## 5.4 Operator Programming Errors

### ◆ Operator Programming Error Codes, Causes, and Possible Solutions

An Operator Programming Error (oPE) occurs when a contradictory parameter is set or an individual parameter is set to an inappropriate value.

The drive will not operate until the parameter or parameters causing the problem are set correctly. An oPE, however, does not trigger an alarm or fault output. If an oPE occurs, investigate the cause and refer to [Table 5.4](#) for the appropriate action. When an oPE appears on the operator display, press the ENTER button to view U1-18 and see which parameter is causing the oPE.

**Table 5.4 oPE Codes, Causes, and Possible Solutions**

HOA Keypad Display	Error Name
oPE01	Drive Capacity Setting Fault
	Drive capacity and the value set to o2-04 do not match.
<b>Cause</b>	<b>Possible Solutions</b>
The drive model selection (o2-04) and the actual capacity of the drive are not the same.	Correct the value set to o2-04.

HOA Keypad Display	Error Name
oPE02	Parameter Range Setting Error
	Use U1-18 to find parameters set outside the range.
<b>Cause</b>	<b>Possible Solutions</b>
Parameters were set outside the possible setting range.	Set parameters to the proper values.
<b>Note:</b> When multiple errors occur simultaneously, other errors are given precedence over oPE02.	

HOA Keypad Display	Error Name
oPE03	Multi-Function Input Selection Error
	A contradictory setting is assigned to multi-function contact inputs H1-01 to H1-08.
<b>Cause</b>	<b>Possible Solutions</b>
<ul style="list-style-type: none"> <li>The same function is assigned to two multi-function inputs.</li> <li>Excludes “Not used” and “External Fault.”</li> </ul>	<ul style="list-style-type: none"> <li>Ensure all multi-function inputs are assigned to different functions.</li> <li>Re-enter the multi-function settings to ensure this does not occur.</li> </ul>
The Up command was set but the Down command was not, or vice versa (settings 10 vs. 11).	Properly set the functions that required for use in combination with other functions.
The Up 2 command was set but the Down 2 command was not, or vice versa (settings 75 vs. 76).	
<ul style="list-style-type: none"> <li>Run/Stop command for a 2-wire sequence was set (H1-□□ = 42), but Forward/Reverse command (H1-□□ = 43) was not.</li> <li>“Drive Enable” is set to multi-function input S1 or S2 (H1-01 = 6A or H1-02 = 6A).</li> </ul>	Properly set the functions that required for use in combination with other functions.
Two of the following functions are set simultaneously: <ul style="list-style-type: none"> <li>Up/Down Command (10 vs. 11)</li> <li>Up 2/Down 2 Command (75 vs. 76)</li> <li>Hold Accel/Decel Stop (A)</li> <li>Analog Frequency Reference Sample/Hold (1E)</li> <li>Offset Frequency 1, 2, 3 Calculations (44, 45, 46)</li> </ul>	<ul style="list-style-type: none"> <li>Check if contradictory settings have simultaneously been assigned to the multi-function input terminals.</li> <li>Correct setting errors.</li> </ul>
The Up/Down command (10, 11) and PID control (b5-01) are enabled simultaneously.	Set b5-01 to 0 to disable control PID or disable the Up/Down command.

## 5.4 Operator Programming Errors

HOA Keypad Display	Error Name
Settings for N.C. and N.O. input for the following functions were selected simultaneously: <ul style="list-style-type: none"> <li>External Search Command 1 and External Search Command 2 (61 vs. 62)</li> <li>Fast Stop N.O. and Fast Stop N.C. (15 vs. 17)</li> <li>KEB for Momentary Power Loss and High Slip Braking (65, 66, 7A, 7B vs. 68)</li> <li>Motor Switch Command and Accel/Decel Time 2 (16 vs. 1A)</li> <li>KEB Command 1 and KEB Command 2 (65, 66 vs. 7A, 7B)</li> <li>FWD Run Command (or REV) and FWD/REV Run Command (2-wire) (40, 41 vs. 42, 43)</li> <li>External DB Command and Drive Enable (60 vs. 6A)</li> <li>Motor Switch Command and Up 2/Down 2 Command (16 vs. 75, 76)</li> </ul>	<ul style="list-style-type: none"> <li>Check if contradictory settings have simultaneously been assigned to the multi-function input terminals.</li> <li>Correct setting errors.</li> </ul>
One of the following settings was entered while H1-□□ = 2 (External Reference 1/2): <ul style="list-style-type: none"> <li>b1-15 = 4 (Pulse Train Input) but the pulse train input selection is not set for the frequency reference (H6-01 &gt; 0)</li> <li>b1-15 or b1-16 set to 3 but no option card is connected</li> <li>Although b1-15 = 1 (Analog Input) and H3-02 or H3-10 are set to 0 (Frequency Bias)</li> </ul> H2-□□ is set to 38 (Drive Enabled) and H1-□□ is not set to 6A (Drive Enable).	Correct the settings for the multi-function input terminal parameters.

HOA Keypad Display	Error Name
oPE04	Initialization Required, Term <=> Ctrl Chg
<b>Cause</b>	<b>Possible Solutions</b>
The drive, control board, or terminal board have been replaced and the parameter settings between the control board and the terminal board no longer match.	Set A1-03 to 5550 to load the parameter settings stored in the terminal board to the drive. Initialize parameters after drive replacement by setting A1-03 to 1110 or 2220.

HOA Keypad Display	Error Name
oPE05	Run Command/Frequency Reference Source Selection Error
<b>Cause</b>	<b>Possible Solutions</b>
Frequency reference is assigned to an option card (b1-01 = 3) and an input option card is not connected to the drive.	Reconnect the input option card to the drive.
The Run command is assigned to an option card (b1-02 = 3) and an input option card is not connected to the drive.	
Frequency reference is assigned to the pulse train input (b1-01 = 4) and terminal RP is not set for frequency reference input (H6-01 > 0)	Set H6-01 to 0.

HOA Keypad Display	Error Name
oPE07	Multi-Function Analog Input Selection Error
<b>Cause</b>	<b>Possible Solutions</b>
At least two analog input terminals are set to the same function (i.e., at least two of these parameters have the same setting: H3-02, H3-10, or H3-06).	Change the settings to H3-02, H3-10, and H3-06 so that functions no longer conflict. <b>Note:</b> Both 0 (Frequency Reference Bias) and F (Not Used) can be set to H3-02, H3-10, or H3-06 simultaneously.

HOA Keypad Display	Error Name
<p>The following simultaneous contradictory settings:</p> <ul style="list-style-type: none"> <li>H3-02, H3-10, or H3-06 = B (PID Feedback) while H6-01 (Pulse Train Input) = 1 (PID Feedback)</li> <li>H3-02, H3-10, or H3-06 = C (PID Target Value) while H6-01 = 2 (pulse train input sets the PID target value)</li> </ul>	Disable one of the PID selections.

HOA Keypad Display	Error Name
oPE09	PID Control Selection Fault
	PID control function selection is incorrect. Requires that PID control is enabled (b5-01 = 1 to 4).
Cause	Possible Solutions
<p>The following simultaneous contradictory settings have occurred:</p> <ul style="list-style-type: none"> <li>b5-15 is not set to 0.0 (PID Sleep Function Operation Level)</li> <li>The stopping method is set to either DC Injection Braking or coast to stop with a timer (b1-03 = 2 or 3).</li> </ul>	<ul style="list-style-type: none"> <li>Set b5-15 to a value other than 0.0.</li> <li>Set the stopping method to coast to stop or ramp to stop (b1-03 = 0 or 1).</li> </ul>
b5-01 is set to 1 or 2, enabling PID control, but the lower limit for the frequency reference (d2-02) is not set to 0 while reverse output is enabled (b5-11 = 1).	Correct the parameter settings.
b5-01 is set to 3 or 4, enabling PID control, but the lower limit for the frequency reference (d2-01) is not 0.	Correct the parameter settings.

HOA Keypad Display	Error Name
oPE10	V/f Data Setting Error
	One of the following setting errors has occurred: E1-09 ≤ E1-07 < E1-06 ≤ E1-11 ≤ E1-04
Cause	Possible Solutions
V/f pattern setting error.	Correct the settings for E1-04, E1-06, E1-07, E1-09, and E1-11.

HOA Keypad Display	Error Name
oPE11	Carrier Frequency Setting Error
	Correct the setting for the carrier frequency.
Cause	Possible Solutions
<p>The following simultaneous contradictory settings have occurred: C6-05 &gt; 6 and C6-04 &gt; C6-03 (carrier frequency lower limit is greater than the upper limit). If C6-05 ≤ 6, the drive operates at C6-03.</p>	Correct the parameter settings.
The upper and lower limits between C6-02 and C6-05 are contradictory.	

## 5.4 Operator Programming Errors

Digital Operator Display	Error Name
oPE18	Online Tuning Parameter Setting Error
	Parameters controlling online tuning are not set correctly.
<b>Cause</b>	<b>Possible Solutions</b>
One of the following errors occurred while online tuning was enabled in OLV (A1-02 = 2): <ul style="list-style-type: none"> <li>E2-02 was set below 30% of the original default value</li> <li>E2-06 was set below 50% of the original default value</li> <li>E2-03 = 0</li> </ul>	Set E2-02, E2-03, and E2-06 to the correct values.

HOA Keypad Display	Error Name
oPE28 <1>	Sequence Timer Error
	One or more of the sequence timers is not set in the correct order.
<b>Cause</b>	<b>Possible Solutions</b>
One of the following contradictory settings is true: <ul style="list-style-type: none"> <li>S2-01 &gt; S2-02</li> <li>S2-06 &gt; S2-07</li> <li>S2-11 &gt; S2-12</li> <li>S2-16 &gt; S2-17</li> </ul>	Correct the parameter settings.

<1> Available in drive software versions PRG: 8551 and earlier.

HOA Keypad Display	Error Name
oPE29	Geothermal Set Error
<b>Cause</b>	<b>Possible Solutions</b>
P1-01 parameter selection is not compatible with Geothermal Mode (b1-01 = 5).	Confirm b1-01 and P1-01 parameter settings.

HOA Keypad Display	Error Name
oPE30	Flow Meter Input Error
<b>Cause</b>	<b>Possible Solutions</b>
Analog and pulse flow meters are programmed simultaneously. H6-01 is set to 5 and either H3-02, H3-06, or H3-10 is set to 22.	Reprogram H6-01, H3-02, H3-06, or H3-10.
Flow meter scaling is set to 0 and the flow meter is being used as PID feedback. P6-01 is set to 0.0, P1-02 is set to 25 and b5-01 is set to a value higher than 0.	Reprogram P6-01, P1-02, or b5-01.

HOA Keypad Display	Error Name
oPE31	Water Level/Suction Pressure/PI Aux
<b>Cause</b>	<b>Possible Solutions</b>
One or both of the following conditions are present: <ul style="list-style-type: none"> <li>More than one of these parameters is set to a non-zero value: Q4-01, Q5-01, or Q6-01.</li> <li>Both Water Level/Suction Pressure (H3-□□ = 23) and PI Aux FB Level (H3-□□ = 27) are programmed.</li> </ul>	Confirm parameter settings of Q4-01, Q5-01, Q6-01, H3-02, H3-06 and H3-10.

HOA Keypad Display	Error Name
oPE32	Incompatible Network Water Level/Suction Pressure Mode
<b>Cause</b>	<b>Possible Solutions</b>
Low Water Level or Suction Pressure Turn-Off Method (P9-51) is restricted to Water Level Source of Analog Only (P9-50 = 0).	Confirm parameter settings for P9-50 and P9-51.



HOA Keypad Display	Error Name
oPE33	Parameter selection is incompatible with the selected network P9-99
Cause	Possible Solutions
<p>When P1-01 = 3 (MEMOBUS Networking) and P9-99 = 0 (A-Version 30034), one of the following parameters has been set:</p> <ul style="list-style-type: none"> <li>• P9-01 = 2 (Stop History)</li> <li>• P9-05 = 3 (Follow Lead Speed)</li> <li>• Q4-01 &gt; 0 (Water Level Enabled)</li> <li>• Q5-01 &gt; 0 (Suction Pressure Control Enabled)</li> <li>• P6-01 &gt; 0 (Flow Meter Enabled) and P9-40 = 3 (Network)</li> </ul>	<p>Confirm parameter settings for P1-01, P9-99, P6-01, P9-05, P9-40, Q4-01, and Q5-01.</p>

HOA Keypad Display	Minor Fault Name
oPE34 DeScale Set Err	De-Scale Setting Error
Cause	Possible Solution
<p>The De-scale function is not allowed while Anti-Jam or MEMOBUS Multiplex is enabled.</p>	<p>Review settings of parameters P1-01, P7-01, or P8-01.</p>

## 5.5 Auto-Tuning Fault Detection

When the Auto-Tuning faults shown below are detected, the fault is displayed on the HOA keypad and the motor coasts to a stop. Auto-Tuning faults do not trigger a multi-function terminal set for fault or alarm output.

An End□ error indicates that although Auto-Tuning has successfully completed, there is some discrepancy in the calculations. If an End□ error occurs, check for the cause of the error using the table in this section, and perform Auto-Tuning again or manually set the motor parameters after fixing the problem. Start the application if no problem can be diagnosed despite the existence of the End□ error.

### ◆ Auto-Tuning Codes, Causes, and Possible Solutions

Table 5.5 Auto-Tuning Codes, Causes, and Possible Solutions

HOA Keypad Display	Error Name
End1	Excessive V/f Setting (detected only during Rotational Auto-Tuning and displayed after Auto-Tuning is complete)
Cause	Possible Solutions
The torque reference exceeded 20% during Auto-Tuning.	<ul style="list-style-type: none"> <li>• Prior to Auto-Tuning, verify the information on the motor nameplate.</li> <li>• Enter proper values from motor nameplate to parameters T1-02 and T1-04 and repeat Auto-Tuning.</li> </ul>
The results from Auto-Tuning the no-load current exceeded 80%.	<ul style="list-style-type: none"> <li>• If possible, disconnect the motor from the load and perform Auto-Tuning. If the load cannot be uncoupled, use the current Auto-Tuning results.</li> </ul>

HOA Keypad Display	Error Name
End2	Motor Iron-Core Saturation Coefficient (detected only during Rotational Auto-Tuning and displayed after Auto-Tuning is complete)
Cause	Possible Solutions
Motor data entered during Auto-Tuning was incorrect.	<ul style="list-style-type: none"> <li>• Make sure the data entered to the T1 parameters match the information written on the motor nameplate.</li> <li>• Restart Auto-Tuning and enter the correct information.</li> </ul>
Results from Auto-Tuning are outside the parameter setting range, assigning the iron-core saturation coefficients (E2-07 and E2-08) to temporary values.	<ul style="list-style-type: none"> <li>• Check and correct faulty motor wiring.</li> <li>• Disconnect the motor from machine and perform Rotational Auto-Tuning.</li> </ul>

HOA Keypad Display	Error Name
End3	Rated Current Setting Alarm (displayed after Auto-Tuning is complete)
Cause	Possible Solutions
The correct current rating printed on the motor nameplate was not entered into T1-04.	<ul style="list-style-type: none"> <li>• Check the setting of parameter T1-04.</li> <li>• Check the motor data and repeat Auto-Tuning.</li> </ul>

HOA Keypad Display	Error Name
End4	Adjusted Slip Calculation Error
Cause	Possible Solutions
The calculated slip is outside the allowable range.	<ul style="list-style-type: none"> <li>• Make sure the data entered for Auto-Tuning is correct.</li> <li>• If possible, perform Rotational Auto-Tuning. If not possible, perform Stationary Auto-Tuning 2.</li> </ul>

HOA Keypad Display	Error Name
End5	Resistance Tuning Error
Cause	Possible Solutions
The calculated resistance value is outside the allowable range.	<ul style="list-style-type: none"> <li>• Double-check the data entered for the Auto-Tuning process.</li> <li>• Check the motor and motor cable connection for faults.</li> </ul>

HOA Keypad Display	Error Name
End6	Leakage Inductance Alarm
Cause	Possible Solutions
The calculated leakage inductance value is outside the allowable range.	Double-check the data entered for the Auto-Tuning process.

HOA Keypad Display	Error Name
End7	No-Load Current Alarm
Cause	Possible Solutions
The entered no-load current value was outside the allowable range.	Check and correct faulty motor wiring.
Auto-Tuning results were less than 5% of the motor rated current.	Double-check the data entered for the Auto-Tuning process.

HOA Keypad Display	Error Name
Er-01	Motor Data Error
Cause	Possible Solutions
Motor data or data entered during Auto-Tuning was incorrect	<ul style="list-style-type: none"> <li>Check that the motor data entered to T1 parameters matches motor nameplate input before Auto-Tuning.</li> <li>Restart Auto-Tuning and enter the correct information.</li> </ul>
Motor output power and motor-rated current settings (T1-02 and T1-04) do not match.	<ul style="list-style-type: none"> <li>Check the drive and motor capacities.</li> <li>Correct the settings of parameters T1-02 and T1-04.</li> </ul>
Motor rated current and detected no-load current are inconsistent.	<ul style="list-style-type: none"> <li>Check the motor rated current and no-load current.</li> <li>Correct the settings of parameters T1-04 and E2-03.</li> </ul>

HOA Keypad Display	Error Name
Er-02	Minor Fault
Cause	Possible Solutions
An alarm was triggered during Auto-Tuning.	Exit the Auto-Tuning menu, check the alarm code, remove the alarm cause, and repeat Auto-Tuning.

HOA Keypad Display	Error Name
Er-03	STOP Button Input
Cause	Possible Solutions
Auto-Tuning canceled by pressing STOP button.	Auto-Tuning did not complete properly. Restart Auto-Tuning.

HOA Keypad Display	Error Name
Er-04	Line-to-Line Resistance Error
Cause	Possible Solutions
Motor data entered during Auto-Tuning was incorrect.	<ul style="list-style-type: none"> <li>Make sure the data entered to the T1 parameters match the information written on the motor nameplate.</li> <li>Restart Auto-Tuning and enter the correct information.</li> </ul>
Results from Auto-Tuning are outside the parameter setting range or the tuning process took too long.	Check and correct faulty motor wiring.
Faulty motor cable or cable connection.	

HOA Keypad Display	Error Name
Er-05	No-Load Current Error
Cause	Possible Solutions
Motor data entered during Auto-Tuning was incorrect.	<ul style="list-style-type: none"> <li>Make sure the data entered to the T1 parameters match the information written on the motor nameplate.</li> <li>Restart Auto-Tuning and enter the correct information.</li> </ul>
Results from Auto-Tuning are outside the parameter setting range or the tuning process took too long.	<ul style="list-style-type: none"> <li>Check and correct faulty motor wiring.</li> <li>Perform Rotational Auto-Tuning.</li> </ul>
The load was too high during Rotational Auto-tuning.	<ul style="list-style-type: none"> <li>Disconnect the motor from machine and restart Auto-Tuning. If motor and load cannot be uncoupled make sure the load is lower than 30%.</li> <li>If a mechanical brake is installed, make sure it is fully lifted during tuning.</li> </ul>

## 5.5 Auto-Tuning Fault Detection

HOA Keypad Display	Error Name
Er-08	Rated Slip Error
Cause	Possible Solutions
Motor data entered during Auto-Tuning was incorrect.	<ul style="list-style-type: none"> <li>Make sure the data entered to the T1 parameters match the information written on the motor nameplate.</li> <li>Restart Auto-Tuning and enter the correct information.</li> </ul>
Results from Auto-Tuning are outside the parameter setting range or the tuning process took too long.	<ul style="list-style-type: none"> <li>Check and correct faulty motor wiring.</li> <li>Perform Rotational Auto-Tuning.</li> </ul>
The load was too high during rotational Auto-tuning.	<ul style="list-style-type: none"> <li>Disconnect the motor from machine and restart Auto-Tuning. If motor and load cannot be uncoupled make sure the load is lower than 30%.</li> <li>If a mechanical brake is installed, make sure it is fully lifted during tuning.</li> </ul>

HOA Keypad Display	Error Name
Er-09	Acceleration Error
Cause	Possible Solutions
The motor did not accelerate for the specified acceleration time.	<ul style="list-style-type: none"> <li>Increase the acceleration time (C1-01).</li> <li>Disconnect the machine from the motor if possible.</li> </ul>
Torque limit when motoring is too low (L7-01 and L7-02)	<ul style="list-style-type: none"> <li>Check L7-01 and L7-02 settings.</li> <li>Increase the setting.</li> </ul>
The load was too high during Rotational Auto-Tuning.	<ul style="list-style-type: none"> <li>Disconnect the motor from machine and restart Auto-Tuning. If motor and load cannot be uncoupled make sure the load is lower than 30%.</li> <li>If a mechanical brake is installed, make sure it is fully lifted during tuning.</li> </ul>

HOA Keypad Display	Error Name
Er-11	Motor Speed Fault
Cause	Possible Solutions
Torque reference is too high.	<ul style="list-style-type: none"> <li>Increase the acceleration time (C1-01).</li> <li>Disconnect the machine from the motor if possible.</li> </ul>

HOA Keypad Display	Error Name
Er-12	Current Detection Error
Cause	Possible Solutions
One of the motor phases is missing: (U/T1, V/T2, W/T3).	Check motor wiring and correct any problems.
The current exceeded the current rating of the drive.	<ul style="list-style-type: none"> <li>Check motor wiring for a short between motor lines.</li> <li>Close any magnetic contactors used between motors.</li> </ul>
The current is too low.	<ul style="list-style-type: none"> <li>Replace the control board or the entire drive. For instructions on replacing the control board, contact Yaskawa or your nearest sales representative.</li> </ul>
Attempted Auto-Tuning without motor connected to the drive.	Connect the motor and restart Auto-Tuning.
Current detection signal error.	Replace the control board or the entire drive. For instructions on replacing the control board, contact Yaskawa or your nearest sales representative.

HOA Keypad Display	Error Name
Er-13	Leakage Inductance Error
Cause	Possible Solutions
Drive was unable to complete tuning for leakage inductance within 300 seconds.	<ul style="list-style-type: none"> <li>Check all wiring and correct any mistakes.</li> <li>Check the motor rated current value written on the motor nameplate and enter the correct value to T1-04.</li> </ul>

HOA Keypad Display	Error Name
Er-17	Reverse Prohibited Error
Cause	Possible Solutions
Drive is prohibited from rotating the motor in reverse while attempting to perform Inertia Tuning.	<ul style="list-style-type: none"> <li>Inertia Auto-Tuning cannot be performed if the drive is restricted from rotating in reverse.</li> <li>Assuming it is acceptable for the application to rotate in reverse, set b1-04 to 0 and then perform Inertia Tuning.</li> </ul>

## 5.6 Copy Function Related Displays

### ◆ Tasks, Errors, and Troubleshooting

The table below lists the messages and errors that may appear when using the Copy function.

When executing the tasks offered by the Copy function, the keypad will indicate the task being performed. When an error occurs, a code appears on the keypad to indicate the error. Note that errors related to the Copy function do not trigger a multi-function output terminal that has been set up to close when a fault or alarm occurs. To clear an error, simply press any key on the keypad and the error display will disappear.

**Table 5.6** lists the corrective action that can be taken when an error occurs.

- Note:**
1. The drive should be fully stopped when using the copy function.
  2. The drive will not accept a Run command while the Copy function is being executed.
  3. Parameters can only be saved to a drive when the voltage class, capacity, control mode, and software version match.

**Table 5.6 Copy Function Task and Error Displays**

Keypad Display	Task
CoPy	Writing Parameter Settings (flashing)
<b>Cause</b>	<b>Possible Solution</b>
Parameters are being written to the drive.	This is not an error.
Keypad Display	Task
CPyE	Error Writing Data
<b>Cause</b>	<b>Possible Solutions</b>
Failed writing parameters	Attempt to write parameters again.
Keypad Display	Task
CSEr	Copy Unit Error
<b>Cause</b>	<b>Possible Solutions</b>
Hardware fault	Replace the HOA keypad or the USB Copy Unit.
Keypad Display	Task
dFPS	Drive Model Mismatch
<b>Cause</b>	<b>Possible Solutions</b>
The drives used in the copy and write process are not the same model. <ul style="list-style-type: none"> <li>• The drive from which the parameters were copied is a different model.</li> <li>• The drive to be written to is a different model.</li> </ul>	<ul style="list-style-type: none"> <li>• Verify the model number of the drive from which the parameters were copied and the model of the drive to which those parameters will be written.</li> <li>• Make sure the two drives are the same model and have the same software version.</li> </ul>
Keypad Display	Task
End	Task Complete
<b>Cause</b>	<b>Possible Solutions</b>
Finished reading, writing, or verifying parameters.	This is not an error.
Keypad Display	Task
iFEr	Communication Error
<b>Cause</b>	<b>Possible Solutions</b>
A communication error occurred between the drive and the HOA keypad or the USB copy unit.	Check the cable connection.
A non-compatible cable is being used to connect the USB Copy Unit and the drive.	Use the cable originally packaged with the USB Copy Unit.

## 5.6 Copy Function Related Displays

Keypad Display	Task
ndAT	Model, Voltage Class, Capacity Mismatch
<b>Cause</b>	<b>Possible Solutions</b>
The drive from which the parameters were copied and the drive to which the parameters will be written have different electrical specifications, capacities, are set to different control modes, or are different models.	Make sure model numbers and specifications are the same for both drives.
The device being used to write the parameters is blank and does not have any parameters saved on it.	Make sure all connections are correct, and copy the parameter settings onto the USB Copy Unit or the HOA keypad.

Keypad Display	Task
rdEr	Error Reading Data
<b>Cause</b>	<b>Possible Solutions</b>
Failed while attempting to read parameter settings from the drive.	Press and hold the READ key on the USB Copy Unit for at least one second to have the unit read parameters from the drive.

Keypad Display	Task
rEAd	Reading Parameter Settings (flashing)
<b>Cause</b>	<b>Possible Solutions</b>
Displayed while the parameter settings are being read onto the USB Copy Unit.	This is not an error.

Keypad Display	Task
vAEr	Voltage Class, Capacity Mismatch
<b>Cause</b>	<b>Possible Solutions</b>
The drive from which the parameters were copied and the drive on which the Verify mode is being performed have different electrical specifications or are a different capacity.	Make sure electrical specifications and capacities are the same for both drives.

Keypad Display	Task
vFyE	Parameter settings in the drive and those saved to the copy function are not the same
<b>Cause</b>	<b>Possible Solutions</b>
Indicates that parameter settings that have been Read and loaded onto the Copy Unit or HOA keypad are different.	To synchronize parameters, either write the parameters saved on the USB Copy Unit or HOA keypad onto the drive, or Read the parameter settings on the drive onto the USB Copy Unit.

Keypad Display	Task
vrFy	Comparing Parameter Settings (flashing)
<b>Cause</b>	<b>Possible Solutions</b>
The Verify mode has confirmed that parameters settings on the drive and parameters read to the copy device are identical.	This is not an error.

## 5.7 HOA Keypad Display Messages

Table 5.7 lists messages and errors that may appear during normal pump operation.

These messages do not trigger multi-function output terminals that have been set up to close when a fault or alarm occurs.

**Table 5.7 HOA Keypad Display Messages**

HOA Keypad Display	Description
Anti Jam Active	Displayed when the drive is performing the anti-jam function.
CrST Cannot Reset	Fault reset was being executed when a Run command was entered. Ensure that a Run command cannot be entered from the external terminals or option during fault reset. Turn off the Run command.
De-staging in X sec	Displayed during multiplexing when either a drive or contactor de-staging is in progress. X sec indicates the time left before the de-staging takes place.
DigitalOut Delay Active	Displayed when the Digital Output Delay function is active.
Feedback Drop Check	Displayed when the drive is determining whether the feedback will change abruptly when the drive enters Sleep Mode. Drop Level is configured by P2-08, Delta Sleep Feedback Drop Level, and P2-09 Feedback Detection Drop Time.
Freq Reduction Active (P3-07)	Maximum Frequency temporarily reduced due to Staging.
LOCK Parameter Locked	Displayed after an attempt to change a parameter when A1-01 = 3. Unlock the keypad by setting A1-01 = 2.
Lube Pump Active	Displayed when the Lube Pump digital output is energized.
Net Geothm Tmp Lost, Chk Source	Displayed when no valid analog Geothermal Temperature source can be found on the network.
Net Pump Err Chk Faulted Pump	Displayed when the drive has been stopped because another drive in the network has a system fault or a Low City Pressure alarm.
Net Start Delay P9-29 Active	Displayed when the MEMOBUS network is waiting for the P9-29 timer to elapse.
Net WtrLvl/SucPr or PIAuxFB Lost	Displayed when the network source for Water Level, Suction Control Pressure, or Aux PI Feedback has been lost. Valid analog source for Water Level, Suction Control Pressure, or Aux PI Feedback cannot be found on the network. Check the source on drives configured as P9-50 ≠ 3.
Network FB Lost Check FB Source	Displayed when no valid analog PI feedback source can be found on the network and network PI feedback has been lost.
PASS MEMOBUS/Modbus Comm. Test Mode Complete	MEMOBUS/Modbus test has finished normally.
Pre Chg Mode Exit in Xsec	Pre-charge 1 or 2 active. X indicates time left before pre-charge exits due to timers (P4-03 + P4-07).
Primer Pump Active </>	The drive is delaying the start of the motor and the Primer Pump (H2-□□ = 8B) digital output is energized.
ScreenMtrStarter Active </>	The drive is delaying the start of the motor and the Screen Motor Starter (H2-□□ = 8B) digital output is energized.
Setpoint Boost Active (P3-11)	Maximum Frequency temporarily reduced due to Staging.
Single Phase Foldback	Displayed when an input phase has been lost, or when excess load is being drawn by the motor in a single phase application.
Sleep Active Min/Max PIAuxLvl </>	Displayed when the PI Aux Feedback falls below the Q6-04/Q6-24 level for longer than the Q6-05 time forcing the drive to go to a sleep condition.
Sleep Active Min Suction Pres	Displayed when the drive has gone to sleep because the suction level has dropped below the level set in Q5-04 for longer than the time set in Q5-05.
Sleep Active Min Water Level	Displayed when the drive has gone to sleep because the water level has dropped below the level set in Q4-04 for longer than the time set in Q4-05.
Sleep Active Wait for Start	Displayed when the drive is in Sleep Mode or when the drive is waiting for the feedback level to reach the level set in P1-04, Start Level.
Sleep AUTO -> Off AUTO Cmd to RUN </>	Displayed when parameter P2-15 is set to 1 (Enabled) and drive has turned-off due to Sleep..
Sleep Boost Active	Displayed when the drive entering Sleep Mode and the pressure setpoint is being boosted. During this time, the U1-01, Frequency Reference, monitor will be updated with the boosted setpoint.
Staging in X sec	Displayed during multiplexing when either a drive or contactor staging is in progress. X sec indicates the time left before the staging takes place.
Start Delay Adjust b1-11	Displayed when the drive start is being delayed by Coast to Stop with Timer (Back Spin Timer). This time is adjusted by parameter b1-11, Coast to Stop with Timer Time.

## 5.7 HOA Keypad Display Messages

HOA Keypad Display	Description
Start Delay Timer Active	Displayed when the feedback level has reached the level set in P1-04, Start Level, and the Start Delay timer is incrementing.
Thrust Mode Thrust Active	Displayed during Thrust Mode.
Utility Delay Adjust by P4-17	Displayed when the drive is delaying the Run command due to the Utility Start Delay Function.

<1> Available in drive software versions PRG: 8552 and later. Not available in drive models 4A0930 and 4A1200.

### ◆ Fault Reset Methods

When a fault occurs, the cause of the fault must be removed and the drive must be restarted. The table below lists the different ways to restart the drive.

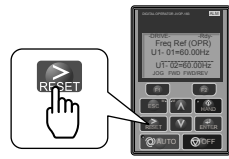
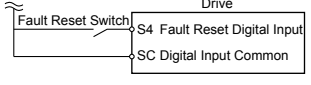
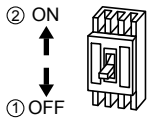
After the Fault Occurs	Procedure	
Fix the cause of the fault, restart the drive, and reset the fault	Press  on the HOA keypad.	
Resetting via a multi-function digital input programmed for Fault Reset (H1-□□ = 14).	For example, close then open the fault signal digital input via terminal S4. S4 is set for "Fault Reset" as default (H1-04 = 14).	
Turn off the main power supply if the above methods do not reset the fault. Reapply power after the HOA keypad display has turned off. When an "SC" error occurs, contact Yaskawa or a Yaskawa agent before cycling the power to the drive.		

**Note:** If the Run command is present, the drive will disregard any attempts to reset the fault. Remove the Run command before attempting to clear a fault situation.



## 5.8 Auto-Tuning

### ◆ Types of Auto-Tuning

The drive offers different types of Auto-Tuning for induction motors. Refer to the tables below to select the type of Auto-Tuning that best suits the application.

### ■ Auto-Tuning for Induction Motors

This feature automatically sets the V/f pattern and motor parameters E1-□□ and E2-□□ for an induction motor.

**Table 5.8 Types of Auto-Tuning for Induction Motors**

Type	Setting	Application Conditions and Benefits	Control Mode	
			V/f	OLV
<b>Stationary Auto-Tuning for Line-to-Line Resistance</b>	T1-01 = 2	<ul style="list-style-type: none"> <li>The drive is used in V/f Control and other Auto-Tuning selections are not possible.</li> <li>Perform when entering motor data manually while using motor cables longer than 50 m.</li> <li>Drive and motor capacities differ.</li> <li>Tunes the drive after the cable between the drive and motor has been replaced with a cable over 50 m long. Assumes Auto-Tuning has already been performed.</li> <li>Should not be used for any vector control modes unless the motor cable has changed.</li> </ul>	YES	YES
<b>Rotational Auto-Tuning for V/f Control</b>	T1-01 = 3	<ul style="list-style-type: none"> <li>Recommended for applications using Speed Estimation Speed Search or using the Energy Saving function in V/f Control.</li> <li>Assumes motor can rotate while Auto-Tuning is executed. Increases accuracy for certain functions like torque compensation, slip compensation, Energy Saving, and Speed Search.</li> </ul>	YES	–
<b>Stationary Auto-Tuning 2</b>	T1-01 = 4	<ul style="list-style-type: none"> <li>Motor and load cannot be decoupled and the load is higher than 30%.</li> <li>A motor test report is available. After entering the no-load current and the rated slip, the drive calculates and sets all other motor-related parameters.</li> </ul>	–	YES

**Table 5.9** lists the data that must be entered for Auto-Tuning. Make sure this data is available before starting Auto-Tuning. The necessary information is usually listed on the motor nameplate or in the motor test report provided by the motor manufacturer.

**Table 5.9 Auto-Tuning Input Data**

Input Value	Input Parameter	Unit	Tuning Type (T1-01)		
			2 Line-to-Line Resistance	3 Rotational for V/f Control	4 Stationary 2
<b>Control Mode</b>	<b>A1-02</b>	–	<b>0, 2</b>	<b>0</b>	<b>2</b>
<b>Motor rated power</b>	T1-02	kW	YES	YES	YES
<b>Motor rated voltage</b>	T1-03	Vac	–	YES	YES
<b>Motor rated current</b>	T1-04	A	YES	YES	YES
<b>Motor rated frequency</b>	T1-05	Hz	–	YES	YES
<b>Number of motor poles</b>	T1-06	-	–	YES	YES
<b>Motor rated speed</b>	T1-07	r/min	–	YES	YES
<b>Motor no-load current</b>	T1-09	A	–	–	YES
<b>Motor rated slip</b>	T1-10	Hz	–	–	YES
<b>Motor iron loss</b>	T1-11	W	–	YES	–

### ◆ Auto-Tuning Interruption and Fault Codes

If tuning results are abnormal or the OFF key is pressed before completion, Auto-Tuning will be interrupted and a fault code will appear on the HOA keypad.

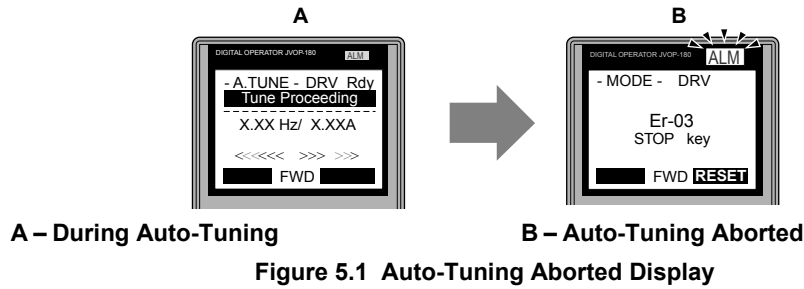

### ◆ Auto-Tuning Operation Example









The following example demonstrates Stationary Auto-Tuning for Line-to-Line Resistance.

#### ■ Selecting the Type of Auto-Tuning

Step		Display/Result
1.	Turn on the power to the drive. The initial display appears.	<pre> - MODE - DRV Rdy Auto Setpoint U5-99= 0.0PSI ----- U1-02= 0.00Hz LSEQ U1-91= 0.0PSI LREF &lt;-MONITOR-&gt;                     </pre>
2.	Press  or  until the Auto-Tuning display appears.	<pre> - MODE - PRG Auto-Tuning AUTO HELP FWD DATA                     </pre>
3.	Press  to begin setting parameters.	<pre> - A.TUNE - PRG Rdy Tuning Mode Sel ----- T1-01= 2 *2* Term Resistance ESC FWD DATA                     </pre>
4.	Press  to display the value for T1-01.	<pre> - A.TUNE - PRG Rdy Tuning Mode Sel ----- T1-01= 2 *2* Term Resistance "2" &lt;- FWD -&gt;                     </pre>
5.	Save the setting by pressing .	Entry Accepted
6.	The display automatically returns to the display shown in Step 3.	<pre> - A.TUNE - PRG Rdy Tuning Mode Sel ----- T1-01= 2 *2* Term Resistance ESC FWD DATA                     </pre>

#### ■ Selecting the Type of Auto-Tuning





















Step		Display/Result
1.	Turn on the power to the drive. The initial display appears.	<pre> - MODE - DRV Rdy FREE (OPR) U1-01= 0.00Hz ----- U1-02= 0.00Hz LSEQ U1-03= 0.00A LREF JOG FWD FWD/REV                     </pre>
2.	Press  or  until the Auto-Tuning display appears.	<pre> - MODE - PRG Auto-Tuning AUTO HELP FWD DATA                     </pre>

Step			Display/Result
3.	Press  to begin setting parameters.	→	- A.TUNE - PRG Rdy Tuning Mode Sel ----- T1-01= 2 *2* Term Resistance  FWD 
4.	Press  to display the value for T1-01.	→	- A.TUNE - PRG Rdy Tuning Mode Sel ----- T1-01= 2 *2* Term Resistance "2"  FWD 
5.	Save the setting by pressing  .	→	Entry Accepted
6.	The display automatically returns to the display shown in Step 3.	→	- A.TUNE - PRG Rdy Tuning Mode Sel ----- T1-01= 2 *2* Term Resistance  FWD 

### ■ Enter Data from the Motor Nameplate

After selecting the type of Auto-Tuning, enter the data required from the motor nameplate.

**Note:** These instructions continue from Step 6 in “Selecting the Type of Auto-Tuning”.

Step			Display/Result
1.	Press  to access the motor output power parameter T1-02.	→	- A.TUNE - PRG Rdy Mtr Rated Power ----- T1-02= 0.75kW (0.00 ~ 650.00) "0.75kW"  FWD 
2.	Press  to view the default setting.	→	- A.TUNE - PRG Rdy Mtr Rated Power ----- T1-02= 000.75kW (0.00 ~ 650.00) "0.75kW"  FWD 
3.	Press  left,  right,  ,  , and  to enter the motor power nameplate data in kW.	→	- A.TUNE - PRG Rdy Mtr Rated Power ----- T1-02= 000.40kW (0.00 ~ 650.00) "0.75kW"  FWD 
4.	Press  to save the setting.	→	Entry Accepted
5.	The display automatically returns to the display in Step 1.	→	- A.TUNE - PRG Rdy Mtr Rated Power ----- T1-02= 0.40kW (0.00 ~ 650.00) "0.75kW"  FWD 
6.	Repeat Steps 1 through 5 to set the following parameters: <ul style="list-style-type: none"> <li>• T1-03, Motor Rated Voltage (Rotational Auto-Tuning for V/f Control only)</li> <li>• T1-04, Motor Rated Current</li> <li>• T1-05, Motor Base Frequency</li> <li>• T1-06, Number of Motor Poles</li> <li>• T1-07, Motor Base Frequency (Rotational Auto-Tuning for V/f Control only)</li> <li>• T1-09, Motor No-Load Current (Stationary Auto-Tuning 2 only)</li> <li>• T1-10, Motor Rated Slip (Stationary Auto-Tuning 2 only)</li> </ul>	→	- A.TUNE - PRG Rated Voltage ----- T1-03= 200.0VAC (0.0 ~ 255.0) "200.0VAC"  FWD   ↓ - A.TUNE - PRG Rated Current ----- T1-04= X.XX A (0.35 ~ 7.00) "X.XX A"  FWD 

**Note:** To execute Stationary Auto-Tuning for line-to-line resistance only, set parameters T1-02 and T1-04.

## 5.8 Auto-Tuning

### ■ Starting Auto-Tuning



**WARNING! Sudden Movement Hazard.** The drive and motor may start unexpectedly during Auto-Tuning, which could result in death or serious injury. Ensure the area surrounding the drive motor and load are clear before proceeding with Auto-Tuning.

**WARNING! Electrical Shock Hazard.** High voltage will be supplied to the motor when Stationary Auto-Tuning is performed even with the motor stopped, which could result in death or serious injury. Do not touch the motor until Auto-Tuning has been completed.

**NOTICE:** Rotational Auto-Tuning will not function properly if a holding brake is engaged on the load. Failure to comply could result in improper operation of the drive. Ensure the motor can freely spin before beginning Auto-Tuning.

Enter the required information from the motor nameplate. Press  to proceed to the Auto-Tuning start display.

**Note:** These instructions continue from Step 6 in “Enter Data from the Motor Nameplate”.

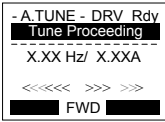
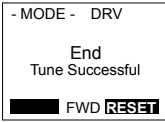
Step			Display/Result
1.	After entering the data listed on the motor nameplate, press  to confirm.	→	
2.	Press  to activate Auto-Tuning. <b>DRV</b> flashes. The drive begins by injecting current into the motor for about 1 min, and then starts to rotate the motor. <b>Note:</b> The first digit on the display indicates which motor is undergoing Auto-Tuning. The second digit indicates the type of Auto-Tuning being performed.	→	
3.	Auto-Tuning finishes in approximately one to two minutes.	→	

## Periodic Inspection & Maintenance

---

This chapter describes the periodic inspection and maintenance of the drive to ensure that it receives the proper care to maintain overall performance.

<b>6.1</b>	<b>INSPECTION.....</b>	<b>302</b>
<b>6.2</b>	<b>PERIODIC MAINTENANCE.....</b>	<b>304</b>
<b>6.3</b>	<b>DRIVE REPLACEMENT.....</b>	<b>306</b>

## 6.1 Inspection

Power electronics have limited life and may exhibit changes in characteristics or performance deterioration after years of use under normal conditions. To help avoid such problems, it is important to perform preventive maintenance and periodic inspection on the drive.

Drives contain a variety of power electronics such as power transistors, semiconductors, capacitors, resistors, fans, and relays. The electronics in the drive serve a critical role in maintaining proper motor control.

Follow the inspection lists provided in this chapter as a part of a regular maintenance program.

**Note:** The drive will require more frequent inspection if it is placed in harsh environments, such as:

- High ambient temperatures
- Frequent starting and stopping
- Fluctuations in the AC supply or load
- Excessive vibrations or shock loading
- Dust, metal dust, salt, sulfuric acid, chlorine atmospheres
- Poor storage conditions.

Perform the first equipment inspection one to two years after installation.

### ◆ Recommended Periodic Inspection

**Table 6.1** outlines the recommended periodic inspections for Yaskawa drive installations. Although periodic inspections should generally be performed once a year; the drive may require more frequent inspection in harsh environments or with rigorous use. Operating and environmental conditions, along with experience in each application, will determine the actual inspection frequency for each installation. Periodic inspection will help to avoid premature deterioration in performance or product failure. Copy this checklist and mark the “Checked” column after each inspection.

### ■ Periodic Inspection

**WARNING! Electrical Shock Hazard.** Do not inspect, connect, or disconnect any wiring while the power is on. Failure to comply can result in serious personal injury. Before servicing, disconnect all power to the equipment. The internal capacitor remains charged even after the power supply is turned off. The charge indicator LED will extinguish when the DC bus voltage is below 50 Vdc. To prevent electric shock, wait for at least the time specified on the warning label; after all indicators are OFF, measure for unsafe voltages to confirm the drive is safe prior to servicing.

**Table 6.1 Periodic Inspection Checklist**

Inspection Area	Inspection Points	Corrective Action	Checked
<b>Main Circuit Periodic Inspection</b>			
<b>General</b>	<ul style="list-style-type: none"> <li>• Inspect equipment for discoloration from overheating or deterioration.</li> <li>• Inspect for damaged or deformed parts.</li> </ul>	<ul style="list-style-type: none"> <li>• Replace damaged components as required.</li> <li>• The drive has few serviceable parts and may require complete drive replacement.</li> </ul>	
	Inspect for dirt, foreign particles, or dust collection on components.	<ul style="list-style-type: none"> <li>• Inspect enclosure door seal if used.</li> <li>• Remove foreign particles and dust with a vacuum cleaner to avoid touching parts.</li> <li>• Replace components if cleaning is not possible.</li> </ul>	
<b>Conductors and Wiring</b>	<ul style="list-style-type: none"> <li>• Inspect wiring and connections for discoloration, damage, or heat stress.</li> <li>• Inspect wire insulation and shielding for wear.</li> </ul>	Repair or replace damaged wiring.	
<b>Terminals</b>	Inspect terminals for stripped, damaged, or loose connections.	Tighten loose screws and replace damaged screws or terminals.	
<b>Relays and Contactors</b>	<ul style="list-style-type: none"> <li>• Inspect contactors and relays for excessive noise during operation.</li> <li>• Inspect coils for signs of overheating such as melted or cracked insulation.</li> </ul>	<ul style="list-style-type: none"> <li>• Check coil voltage for overvoltage or undervoltage conditions.</li> <li>• Replace damaged removable relays, contactors, or circuit board.</li> </ul>	
<b>Electrolytic Capacitor</b>	<ul style="list-style-type: none"> <li>• Inspect for leaking, discoloration, or cracks.</li> <li>• Check if the cap has come off, for any swelling, or if the sides have burst open.</li> </ul>	The drive has few serviceable parts and may require complete drive replacement.	
<b>Diode, IGBT (Power Transistor)</b>	Inspect for dust or other foreign material collected on the surface.	Remove foreign particles and dust with a vacuum cleaner to avoid touching parts.	

Inspection Area	Inspection Points	Corrective Action	Checked
<b>Motor Periodic Inspection</b>			
<b>Operation Check</b>	Check for increased vibration or abnormal noise.	Stop the motor and contact qualified maintenance personnel as required.	
<b>Control Circuit Periodic Inspection</b>			
<b>General</b>	<ul style="list-style-type: none"> <li>Inspect terminals for stripped, damaged, or loose connections.</li> <li>Make sure all terminals have been properly tightened.</li> </ul>	<ul style="list-style-type: none"> <li>Tighten loose screws and replace damaged screws or terminals.</li> <li>If terminals are integral to a circuit board, then board or drive replacement may be required.</li> </ul>	
<b>Circuit Boards</b>	Check for any odor, discoloration, and rust. Make sure connections are properly fastened and that no dust or oil mist has accumulated on the surface of the board.	<ul style="list-style-type: none"> <li>Fix any loose connections.</li> <li>If an antistatic cloth or vacuum plunger cannot be used, replace the board.</li> <li>Do not use any solvents to clean the board.</li> <li>Remove foreign particles and dust with a vacuum cleaner to avoid touching parts.</li> </ul> <p>The drive has few serviceable parts and may require complete drive replacement.</p>	
<b>Cooling System Periodic Inspection</b>			
<b>Cooling Fan, Circulation Fan, Control Board Cooling Fan</b>	<ul style="list-style-type: none"> <li>Check for abnormal oscillation or unusual noise.</li> <li>Check for damaged or missing fan blades.</li> </ul>	Replace as required.	
<b>Heatsink</b>	Inspect for dust or other foreign material collected on the surface.	Remove foreign particles and dust with a vacuum cleaner to avoid touching parts.	
<b>Air Duct</b>	Inspect air intake and exhaust openings. They must be free from obstruction and properly installed.	<ul style="list-style-type: none"> <li>Visually inspect the area.</li> <li>Clear obstructions and clean air duct as required.</li> </ul>	
<b>Display Periodic Inspection</b>			
<b>HOA Keypad</b>	<ul style="list-style-type: none"> <li>Make sure data appears on the display properly.</li> <li>Inspect for dust or other foreign material that may have collected on surrounding components.</li> </ul>	<ul style="list-style-type: none"> <li>Contact the nearest sales office if there is any trouble with the display or keypad.</li> <li>Clean the HOA keypad.</li> </ul>	

## 6.2 Periodic Maintenance

The drive has Maintenance Monitors that keep track of component wear. This feature provides advance maintenance warning and eliminates the need to shut down the entire system for unexpected problems. The drive allows the user to check predicted maintenance periods for the components listed below.

- Cooling Fan, Circulation Fan, Control Board Cooling Fan
- Electrolytic Capacitors
- Inrush Prevention Circuit
- IGBTs

For replacement parts, contact the distributor where the drive was purchased or contact Yaskawa directly.

### ◆ Replacement Parts

**Table 6.2** contains the estimated performance life of components that require replacement during the life of the drive. Only use Yaskawa replacement parts for the appropriate drive model and revision.

**Table 6.2 Estimated Performance Life**

Component	Estimated Performance Life
Cooling Fan, Circulation Fan	10 years
Electrolytic Capacitors	10 years <1>

<1> Electrolytic capacitors cannot be replaced on some lower capacity models. Complete drive replacement may be required for these models.

**NOTICE:** *Estimated performance life based on specific usage conditions. These conditions are provided for the purpose of replacing parts to maintain performance. Some parts may require more frequent replacement due to poor environments or rigorous use.*

*Usage conditions for estimated performance life:*

*Ambient temperature: Yearly average of 40 °C (IP20/IP00 enclosure)*

*Yearly average of 30 °C (side-by-side mounting/NEMA 1, UL type 1 enclosure/finless drive or external heatsink installation)*

### ■ Performance Life Monitors Maintenance Monitors

The drive calculates the maintenance period for components that may require replacement during the life of the drive. A percentage of the maintenance period is displayed on the HOA keypad by viewing the appropriate monitor parameter.

When the maintenance period reaches 100%, there is increased risk that the drive may malfunction. Yaskawa recommends checking the maintenance period regularly to ensure maximum performance life.

**Refer to Recommended Periodic Inspection on page 302** for more details.

**Table 6.3 Performance Life Monitors Used for Component Replacement**

Parameter	Component	Contents
U4-03	Cooling Fan Circulation Fan	Displays the accumulated operation time of the fan, from 0 to 99999 hours. This value is automatically reset to 0 once it reaches 99999.
U4-04	Control Board Cooling Fan	Displays the accumulated fan operation time as a percentage of the specified maintenance period.
U4-05	DC Bus Capacitors	Displays the accumulated time the capacitors are used as a percentage of the specified maintenance period.
U4-06	Inrush (pre-charge) Relay	Displays the number of times the drive is powered up as a percentage of the performance life of the inrush circuit.



## ■ Alarm Outputs for Maintenance Monitors

An output can be set up to inform the user when a specific components has neared its expected performance life.

When one of multi-function digital output terminals has been assigned the maintenance monitor function (H2-□□ = 2F), the terminal will close when the cooling fan, DC bus capacitors, or DC bus pre-charge relay reach 90% of the expected performance life, or when the IGBTs have reached 50% of their expected performance life. Additionally, the HOA keypad operator will display an alarm like shown in [Table 6.4](#) to indicate the specific components that may need maintenance.

**Table 6.4 Maintenance Alarms**

HOA Keypad Alarm Display		Function	Corrective Action
LF-1 <>	LT-1	The cooling fans have reached 90% of their designated life time.	Replace the cooling fan.
LF-2 <>	LT-2	The DC bus capacitors have reached 90% of their designated life time.	Contact a Yaskawa representative or the nearest Yaskawa sales office on possible drive replacement.
LF-3 <>	LT-3	The pre-charge circuit has reached 90% of its designated life time.	Contact a Yaskawa representative or the nearest Yaskawa sales office on possible drive replacement.
LF-4 <>	LT-4	The IGBTs have reached 50% of their designated life time.	Check the load, carrier frequency, and output frequency.
TrPC <>	TrPC	The IGBTs have reached 90% of their designated life time.	Contact a Yaskawa representative or the nearest Yaskawa sales office on possible drive replacement.

- <1> This alarm message will be output only if the Maintenance Monitor function is assigned to one of the digital outputs (H2-□□ = 2F). The alarm will also trigger a digital output that is programmed for alarm indication (H2-□□ = 10).
- <2> This alarm message will always be output, even if the Maintenance Monitor function is not assigned to any of the digital outputs (H2-□□ = 2F). The alarm will also trigger a digital output that is programmed for alarm indication (H2-□□ = 10).

## ■ Related Drive Parameters

Use parameters o4-03, o4-05, o4-07, and o4-09 to reset a Maintenance Monitor to zero after replacing a specific component. [Refer to Parameter List on page 349](#) for details on parameter settings.

**NOTICE:** *If these parameters are not reset after the corresponding parts have been replaced, the Maintenance Monitor function will continue to count down the performance life from the value that was reached with the old part. If the Maintenance Monitor is not reset, the drive will not have the correct value of the performance life for the new component.*

# 6.3 Drive Replacement

### ◆ Replacing the Drive

**WARNING! Electrical Shock Hazard.** Do not connect or disconnect wiring while the power is on. Failure to comply can result in serious personal injury. Before servicing the drive, disconnect all power to the equipment. The internal capacitor remains charged even after the power supply is turned off. After shutting off the power, wait for at least the amount of time specified on the drive before touching any components.

**WARNING! Electrical Shock Hazard.** Do not allow unqualified personnel to perform work on the drive. Failure to comply could result in serious injury. Installation, maintenance, inspection and servicing must be performed only by authorized personnel familiar with installation, adjustment and maintenance of AC drives.

**NOTICE:** Observe proper electrostatic discharge procedures (ESD) when handling the drive and circuit boards. Failure to comply may result in ESD damage to the drive circuitry.

The following procedure explains how to replace a drive.

This section provides instructions for drive replacement only.

To install option boards or other types of options, refer to the specific manuals for those options.

**NOTICE:** When transferring a braking transistor, braking resistor, or other type of option from a damaged drive to a new replacement drive, make sure it is working properly before reconnecting it to the new drive. Replace broken options to prevent immediate breakdown of the replacement drive.

1. Remove the terminal cover.

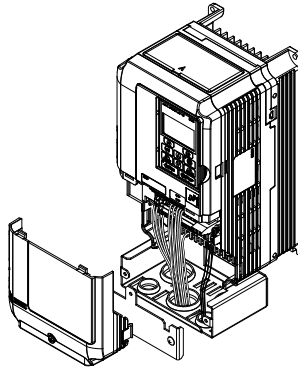

Figure 6.1 Remove the Terminal Cover

2. Loosen the screws holding the terminal board in place. Remove the screw securing the bottom cover and remove the bottom cover from the drive.

**Note:** IP00/Open Type enclosure drives do not have a bottom cover or conduit.

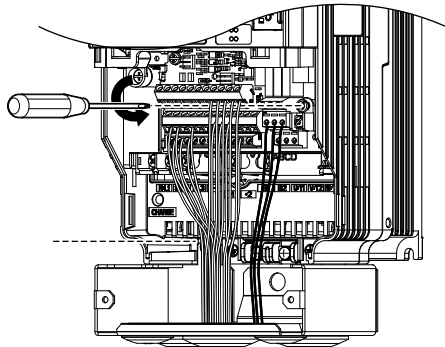

Figure 6.2 Unscrew the Terminal Board and Remove the Bottom Cover

3. Slide the terminal board as illustrated by the arrows to remove it from the drive along with the bottom cover.

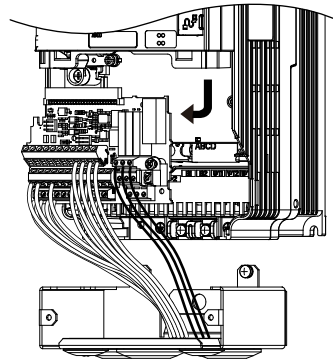

Figure 6.3 Remove the Terminal Board

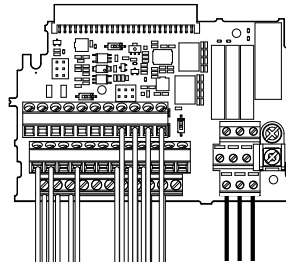

Figure 6.4 Disconnected Removable Terminal Board

4. Disconnect all option cards and options, making sure they are intact before reusing.
5. Replace the drive and wire the main circuit.

#### ■ Installing the Drive

1. After wiring the main circuit, connect the terminal block to the drive as shown in [Figure 6.5](#). Use the installation screw to fasten the terminal block into place.

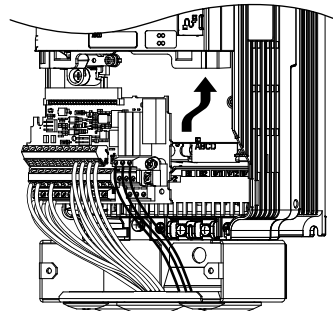

Figure 6.5 Install the Terminal Board

2. Reconnect options for the new drive the same way the options were connected in the old drive. Connect option boards to the same option ports in the new drive that were used in the old drive.
3. Replace the terminal cover.
4. After powering on the drive, all parameter settings are transferred from the terminal board to the drive memory. If an oPE04 error occurs, load the parameter settings saved on the terminal board to the new drive by setting parameter A1-03 to 5550. Reset the Maintenance Monitor function timers by setting parameters o4-01 through o4-12 to 0, and parameter o4-13 to 1.

**This Page Intentionally Blank**

## Peripheral Devices & Options

---

This chapter explains option installation procedures for the drive.

<b>7.1</b>	<b>OPTION CARD INSTALLATION.....</b>	<b>310</b>
------------	--------------------------------------	------------

## 7.1 Option Card Installation

This section provides instructions on installing option cards.

### ◆ Prior to Installing the Option

Prior to installing the option, wire the drive, make necessary connections to the drive terminals, and verify that the drive functions normally without the option installed.

**Table 7.1** below lists the number of options that can be connected to the drive and the drive ports for connecting those options.

**Table 7.1 Option Installation**

Option	Port/Connector	Number of Options Possible
AO-A3, DO-A3	CN5-A, B, C	1
SI-B3 <1>, SI-C3, SI-EN3 <1>, SI-EM3 <1>, SI-EP3 <1>, SI-ES3 <1>, SI-ET3 <1>, SI-N3, SI-P3, SI-S3, SI-T3, SI-W3 <1>, AI-A3 <2>, DI-A3 <2>	CN5-A	1

<1> Not available with models 4A0930 and 4A1200.

<2> When using AI-A3 and DI-A3 as monitors, the card can be connected to any of CN5-A, CN5-B or CN5-C. The input status of AI-A3 can then be viewed using U1-21, U1-22, and U1-23, and the input status of DI-A3 can then be viewed using U1-17.

**Figure 7.1** shows an exploded view of the drive with the option and related components for reference.

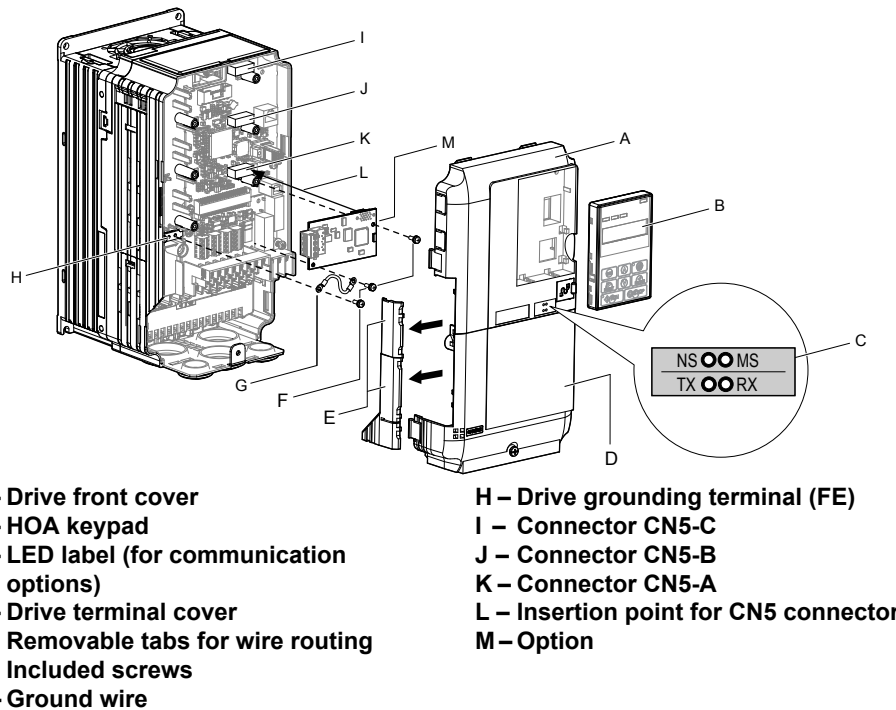

**Figure 7.1 Drive Components with Option**

## ◆ Communication Option Installation Example

Remove the front covers of the drive before installing the option. Communication options can be inserted only into the CN5-A connector located on the drive control board.

### Preparing the Drive

1. Shut off power to the drive, wait the appropriate amount of time for voltage to dissipate, then remove the HOA keypad (B) and front covers (A, D). Front cover removal varies by model.

**DANGER!** *Electrical Shock Hazard. Do not connect or disconnect wiring while the power is on. Failure to comply will result in death or serious injury. Before installing the option, disconnect all power to the drive. The internal capacitor remains charged even after the power supply is turned off. The charge indicator LED will extinguish when the DC bus voltage is below 50 Vdc. To prevent electric shock, wait at least five minutes after all indicators are off and measure the DC bus voltage level to confirm safe level.*

**NOTICE:** *Damage to Equipment. Observe proper electrostatic discharge procedures (ESD) when handling the option, drive, and circuit boards. Failure to comply may result in ESD damage to circuitry.*

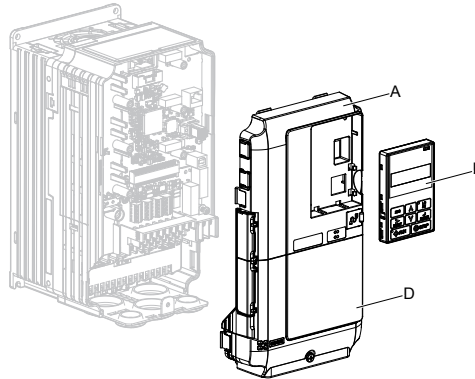

Figure 7.2 Remove the Front Covers and HOA Keypad

2. With the front covers and HOA keypad removed, apply the LED label (C) in the appropriate position on the drive top front cover (A).

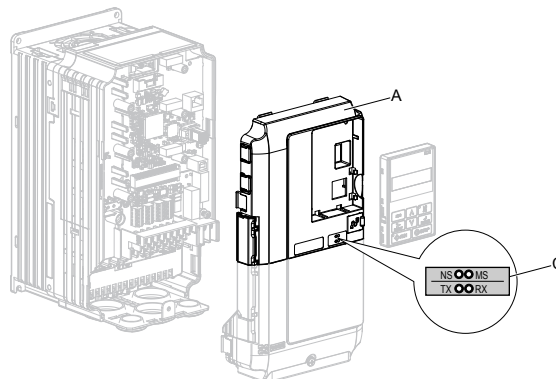

Figure 7.3 Apply the LED Label

### Connecting Option and Ground Wire

1. Insert the option (M) into the **CN5-A** connector (K) located on the drive and fasten it using one of the included screws (F).

## 7.1 Option Card Installation

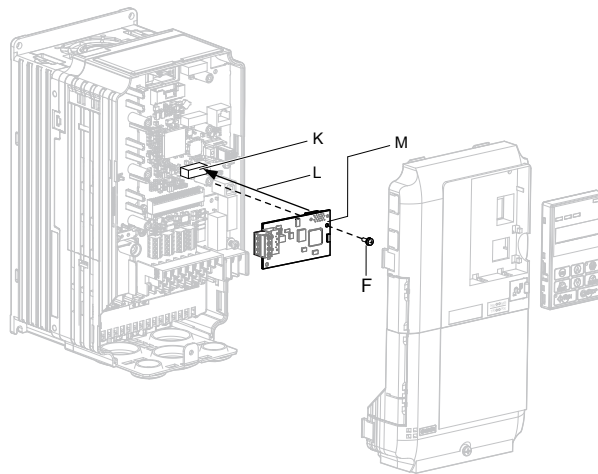

Figure 7.4 Insert the Option

2. Connect the ground wire (G) to the ground terminal (H) using one of the remaining provided screws (F). Connect the other end of the ground wire (G) to the remaining ground terminal and installation hole on the option (M) using the last remaining provided screw (F) and tighten both screws to 0.5 ~ 0.6 N m or (4.4 ~ 5.3 lbs).

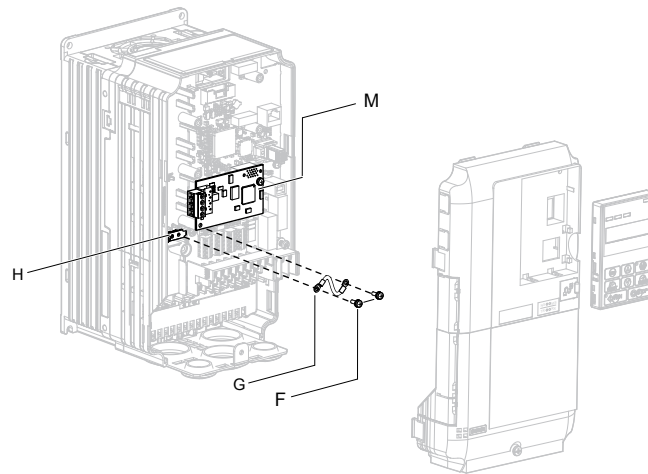

Figure 7.5 Connect the Ground Wire

**Note:** There are two screw holes on the drive for use as ground terminals. When connecting three options, two ground wires will need to share the same drive ground terminal.

### Wiring the Option

1. Route the option wiring.

Depending on the drive model, some drives may require routing the wiring through the side of the front cover to the outside to provide adequate space for the wiring. In these cases, using diagonal cutting pliers, cut out the perforated openings on the left side of the drive front cover. Sharp edges along the cut out should be smoothed down with a file or sand paper to prevent any damage to the wires.

When installing option cards to models 2A0004 to 2A0040, 4A0002 to 4A0023, and 5A0003 to 5A0011, it may be necessary to route the cables connected to the option through the top cover to the outside. Models 2A0056 to 2A0415, 4A0031 to 4A1200, and 5A0017 to 5A0242 have enough space to keep all wiring inside the unit.

2. Connect the communication cables to the option terminal block (TB1).

**Note:** Separate the communications cables from the main circuit cables and other wiring and power cables. Use properly grounded shielded cables for the communication cables to prevent problems caused by electrical interference.

### Replacing the Drive Covers and HOA Keypad

1. Replace and secure the front covers of the drive (A, D) and replace the HOA keypad (B).



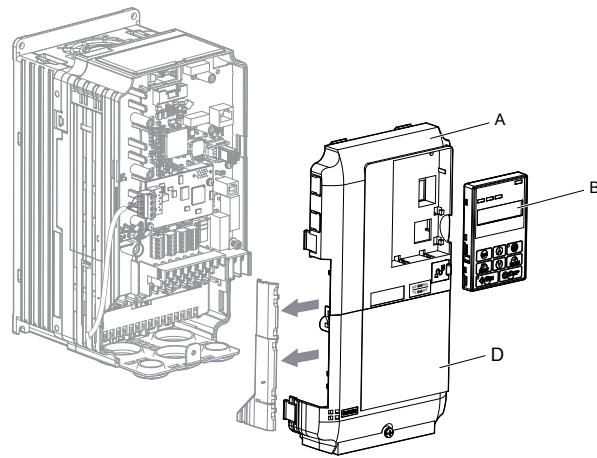

**Figure 7.6** Replace the Front Covers and HOA Keypad

**Note:** Take proper precautions when wiring the option so that the front covers will easily fit back onto the drive. Make sure no cables are pinched between the front covers and the drive when replacing the covers.

**This Page Intentionally Blank**

# Appendix: A

## Specifications

---

<b>A.1</b>	<b>POWER RATINGS.....</b>	<b>316</b>
<b>A.2</b>	<b>DRIVE SPECIFICATIONS.....</b>	<b>325</b>
<b>A.3</b>	<b>DRIVE WATT LOSS DATA.....</b>	<b>327</b>
<b>A.4</b>	<b>DRIVE DERATING DATA.....</b>	<b>329</b>

## A.1 Power Ratings

### ◆ Three-Phase 200 V Class Drive Models 2A0004 to 2A0030

Table A.1 Power Ratings (Three-Phase 200 V Class)

Item		Specification								
Drive Model		2A0004	2A0006	2A0008	2A0010	2A0012	2A0018	2A0021	2A0030	
Maximum Applicable Motor Capacity (HP) <1>	ND Rating	0.75	1	2	3	3	5	7.5	10	
	Input Current (A) <2>	3.9	7.3	8.8	10.8	13.9	18.5	24	37	
Input	Rated Voltage Rated Frequency	Three-phase 200 to 240 Vac 50/60 Hz/270 to 340 Vdc <3>								
	Allowable Voltage Fluctuation	-15 to 10%								
	Allowable Frequency Fluctuation	±5%								
	Input Power (kVA)	ND Rating	2.2	3.1	4.1	5.8	7.8	9.5	14	18
Output	Rated Output Capacity (kVA) <4>	ND Rating <5>	1.3	2.3	3	3.7	4.6	6.7	8	11.4
	Rated Output Current (A)	ND Rating <5>	3.5	6	8	9.6	12	17.5	21	30
	Overload Tolerance	ND Rating: 120% of rated output current for 60 s (Derating may be required for applications that start and stop frequently)								
	Carrier Frequency	User-adjustable between 1 and 15 kHz <5>								
	Maximum Output Voltage (V)	Three-phase 200 to 240 V (proportional to input voltage)								
Maximum Output Frequency (Hz)	400 Hz (user-set)									

- <1> The motor capacity (HP) refers to a NEC rated 4-pole motor. The rated output current of the drive output amps should be equal to or greater than the motor current. Select the appropriate capacity drive if operating the motor continuously above motor nameplate current.
- <2> Assumes operation at the rated output current. Input current rating varies depending on the power supply transformer, input reactor, wiring connections, and power supply impedance.
- <3> DC is not available for UL/CE standards.
- <4> Rated motor capacity is calculated with a rated output voltage of 220 V.
- <5> Carrier frequency default setting is Swing PWM 1 (C6-02 = 7). C6-02 settings 1, 7, 8, 9, and A do not require current derating. All other settings raise the carrier frequency and require current derating.

## ◆ Three-Phase 200 V Class Drive Models 2A0040 to 2A0211

Table A.2 Power Ratings Continued (Three-Phase 200 V Class)

Item		Specification								
Drive Model		2A0040	2A0056	2A0069	2A0081	2A0110	2A0138	2A0169	2A0211	
Maximum Applicable Motor Capacity (HP) <2>	ND Rating	15	20	25	30	40	50	60	75	
	Input Current (A) <2>	52	68	80	96	111	136	164	200	
Input	Rated Voltage Rated Frequency	Three-phase 200 to 240 Vac 50/60 Hz/270 to 340 Vdc <3>								
	Allowable Voltage Fluctuation	-15 to 10%								
	Allowable Frequency Fluctuation	±5%								
	Input Power (kVA)	ND Rating	27	36	44	52	51	62	75	91
Output	Rated Output Capacity (kVA) <4>	ND Rating <5>	15.2	21	26	31	42	53	64	80
	Rated Output Current (A)	ND Rating <5>	40	56	69	81	110	138	169	211
	Overload Tolerance	ND Rating: 120% of rated output current for 60 s (Derating may be required for applications that start and stop frequently)								
	Carrier Frequency	User-adjustable between 1 and 15 kHz <5>						User-adjustable between 1 and 10 kHz <5>		
	Maximum Output Voltage (V)	Three-phase 200 to 240 V (proportional to input voltage)								
Maximum Output Frequency (Hz)	400 Hz (user-set)									

- <1> The motor capacity (HP) refers to a NEC rated 4-pole motor. The rated output current of the drive output amps should be equal to or greater than the motor current. Select the appropriate capacity drive if operating the motor continuously above motor nameplate current.
- <2> Assumes operation at the rated output current. Input current rating varies depending on the power supply transformer, input reactor, wiring connections, and power supply impedance.
- <3> DC is not available for UL/CE standards.
- <4> Rated motor capacity is calculated with a rated output voltage of 220 V.
- <5> Carrier frequency default setting is Swing PWM 1 (C6-02 = 7). C6-02 settings 1, 7, 8, 9, and A do not require current derating. All other settings raise the carrier frequency and require current derating.

### ◆ Three-Phase 200 V Class Drive Models 2A0250 to 2A0415

Table A.3 Power Ratings Continued (Three-Phase 200 V Class)

Item		Specification			
Drive Models		2A0250	2A0312	2A0360	2A0415
<b>Maximum Applicable Motor Capacity (HP)</b> <1>		100	125	150	175
<b>Input Current (A)</b> <2>		271	324	394	471
<b>Input</b>	<b>Rated Voltage</b> <b>Rated Frequency</b>	Three-phase 200 to 240 Vac 50/60 Hz/270 to 340 Vdc <3>			
	<b>Allowable Voltage Fluctuation</b>	-15 to 10%			
	<b>Allowable Frequency Fluctuation</b>	±5%			
	<b>Input Power (kVA)</b>	124	148	180	215
<b>Rated Output Capacity (kVA)</b> <4>		95	119	137	158
<b>Rated Output Current (A)</b>		250	312	360	415
<b>Output</b>	<b>Overload Tolerance</b>	ND Rating: 120% of rated output current for 60 s (Derating may be required for applications that start and stop frequently)			
	<b>Carrier Frequency</b>	User-adjustable between 1 and 10 kHz <5>			
	<b>Maximum Output Voltage (V)</b>	Three-phase 200 to 240 V (proportional to input voltage)			
	<b>Maximum Output Frequency (Hz)</b>	400 Hz (user-set)			

- <1> The motor capacity (HP) refers to a NEC rated 4-pole motor. The rated output current of the drive output amps should be equal to or greater than the motor current. Select the appropriate capacity drive if operating the motor continuously above motor nameplate current.
- <2> Assumes operation at the rated output current. Input current rating varies depending on the power supply transformer, input reactor, wiring connections, and power supply impedance.
- <3> DC is not available for UL/CE standards.
- <4> Rated motor capacity is calculated with a rated output voltage of 220 V.
- <5> Carrier frequency default setting is Swing PWM 1 (C6-02 = 7). C6-02 settings 1, 7, 8, 9, and A do not require current derating. All other settings raise the carrier frequency and require current derating.

## ◆ Three-Phase 400 V Class Drive Models 4A0002 to 4A0031

Table A.4 Power Ratings (Three-Phase 400 V Class)

Item		Specification									
Drive Models		4A0002	4A0004	4A0005	4A0007	4A0009	4A0011	4A0018	4A0023	4A0031	
Maximum Applicable Motor Capacity (HP) <1>	ND Rating	0.75	2	3	3	5	7.5	10	15	20	
	Input Current (A) <2>	2.1	4.3	5.9	8.1	9.4	14	20	24	38	
Input	Rated Voltage Rated Frequency	Three-phase: 380 to 480 Vac 50/60 Hz/510 to 680 Vdc <3>									
	Allowable Voltage Fluctuation	-15 to 10%									
	Allowable Frequency Fluctuation	±5%									
	Input Power (kVA)	ND Rating	2.3	4.3	6.1	8.1	10.0	14.5	19.4	28.4	37.5
Output	Rated Output Capacity (kVA) <4>	ND Rating <5>	1.6	3.1	4.1	5.3	6.7	8.5	13.3	17.5	24
	Rated Output Current (A)	ND Rating <5>	2.1	4.1	5.4	6.9	8.8	11.1	17.5	23	31
	Overload Tolerance	ND Rating: 120% of rated output current for 60 s (Derating may be required for applications that start and stop frequently)									
	Carrier Frequency	User-adjustable between 1 and 15 kHz <5>									
	Maximum Output Voltage (V)	Three-phase: 380 to 480 V (proportional to input voltage)									
	Maximum Output Frequency (Hz)	400 Hz (user-adjustable)									

- <1> The motor capacity (HP) refers to a NEC rated 4-pole motor. The rated output current of the drive output amps should be equal to or greater than the motor current. Select the appropriate capacity drive if operating the motor continuously above motor nameplate current.
- <2> Assumes operation at the rated output current. Input current rating varies depending on the power supply transformer, input reactor, wiring conditions, and power supply impedance.
- <3> DC is not available for UL/CE standards.
- <4> Rated motor capacity is calculated with a rated output voltage of 440 V.
- <5> Carrier frequency default setting is Swing PWM 1 (C6-02 = 7). C6-02 settings 1, 7, 8, 9, and A do not require current derating. All other settings raise the carrier frequency and require current derating.

### ◆ Three-Phase 400 V Class Drive Models 4A0038 to 4A0165

Table A.5 Power Ratings Continued (Three-Phase 400 V Class)

Item		Specification								
Drive Models		4A0038	4A0044	4A0058	4A0072	4A0088	4A0103	4A0139	4A0165	
Maximum Applicable Motor Capacity (HP) <1>	ND Rating	25	30	40	50	60	75	100	125	
	Input Current (A) <2>	44	52	58	71	86	105	142	170	
Input	Rated Voltage Rated Frequency	Three-phase: 380 to 480 Vac 50/60 Hz/510 to 680 Vdc <3>								
	Allowable Voltage Fluctuation	-15 to 10%								
	Allowable Frequency Fluctuation	±5%								
	Input Power (kVA)	ND Rating	46.6	54.9	53.0	64.9	78.6	96.0	130	156
Output	Rated Output Capacity (kVA) <4>	ND Rating <5>	29	34	44	55	67	78	106	126
	Rated Output Current (A)	ND Rating <5>	38	44	58	72	88	103	139	165
	Overload Tolerance	ND Rating: 120% of rated output current for 60 s (Derating may be required for applications that start and stop frequently)								
	Carrier Frequency	User-adjustable between 1 and 15 kHz <5>						User-adjustable between 1 and 10 kHz <5>		
	Maximum Output Voltage (V)	Three-phase: 380 to 480 V (proportional to input voltage)								
Maximum Output Frequency (Hz)	400 Hz (user-adjustable)									

- <1> The motor capacity (HP) refers to a NEC rated 4-pole motor. The rated output current of the drive output amps should be equal to or greater than the motor current. Select the appropriate capacity drive if operating the motor continuously above motor nameplate current.
- <2> Assumes operation at the rated output current. Input current rating varies depending on the power supply transformer, input reactor, wiring conditions, and power supply impedance.
- <3> DC is not available for UL/CE standards.
- <4> Rated motor capacity is calculated with a rated output voltage of 440 V.
- <5> Carrier frequency default setting is Swing PWM 1 (C6-02 = 7). C6-02 settings 1, 7, 8, 9, and A do not require current derating. All other settings raise the carrier frequency and require current derating.



## ◆ Three-Phase 400 V Class Drive Models 4A0208 to 4A1200

Table A.6 Power Ratings Continued (Three-Phase 400 V Class)

Item		Specification								
Drive Models		4A0208	4A0250	4A0296	4A0362	4A0414	4A0515	4A0675	4A0930	4A1200
Maximum Applicable Motor Capacity (HP) <1>	ND Rating	150	200	250	300	350	400-450	500-550	750	1000
	HD Rating	125-150	150	200	250	300	350	400-450-500	650	900
Input Current (A) <2>	ND Rating	207	248	300	346	410	465	657	922	1158
	HD Rating	170	207	248	300	346	410	584	830	1031
Input	Rated Voltage Rated Frequency	Three-phase: 380 to 480 Vac 50/60 Hz/510 to 680 Vdc <3>								
	Allowable Voltage Fluctuation	-15 to 10%								
	Allowable Frequency Fluctuation	±5%								
	Input Power (kVA)	ND Rating	189	227	274	316	375	425	601	843
HD Rating		155	189	227	274	316	375	534	759	943
Rated Output Capacity (kVA) <4>	ND Rating <5>	189	227	274	316	375	425	601	843	1059
	HD Rating	137 <6>	165 <6>	198 <6>	232 <6>	282 <6>	343 <5>	461 <5>	617 <5>	831 <5>
Rated Output Current (A)	ND Rating <5>	208	250	296	362	414	515	675	930	1200
	HD Rating	180 <6>	216 <6>	260 <6>	304 <6>	370 <7>	450 <5>	605 <5>	810 <5>	1090 <5>
Output	Overload Tolerance	ND Rating: 120% of rated output current for 60 s HD Rating: 150% of rated output current for 60 s (Derating may be required for applications that start and stop frequently)								
	Carrier Frequency	User-adjustable between 1 and 10 kHz					User-adjustable between 1 and 5 kHz			
	Maximum Output Voltage (V)	Three-phase: 380 to 480 Vac (proportional to input voltage)							0.95 × [input voltage]	
	Maximum Output Frequency (Hz)	400 Hz (user-adjustable)								

<1> The motor capacity (HP) refers to a NEC rated 4-pole motor. The rated output current of the drive output amps should be equal to or greater than the motor current. Select the appropriate capacity drive if operating the motor continuously above motor nameplate current.

<2> Assumes operation at the rated output current. Input current rating varies depending on the power supply transformer, input reactor, wiring conditions, and power supply impedance.

<3> DC input is not available for UL standards.

<4> Rated motor capacity is calculated with a rated output voltage of 440 V.

<5> Carrier frequency is set to 2 kHz. Current derating is required in order to raise the carrier frequency.

<6> Carrier frequency can be increased to 5 kHz while keeping this current derating. Higher carrier frequency settings require derating.

<7> Carrier frequency can be increased to 5 kHz while keeping this current derating. Higher carrier frequency settings require derating.

### ◆ Three-Phase 600 V Class Drive Models 5A0003 to 5A0032

Table A.7 Power Ratings (Three-Phase 600 V Class)

Item		Specification										
Drive Models		5A0003	5A0004	5A0006	5A0009	5A0011	5A0017	5A0022	5A0027	5A0032		
Input	Maximum Applicable Motor Capacity (HP) <1>	ND Rating	2	3	5	7.5	10	15	20	25	30	
	Input Current (A) <2>	ND Rating	3.6	5.1	8.3	12	16	23	31	38	45	
	Rated Voltage Rated Frequency		Three-phase 500 to 600 Vac 50/60 Hz									
	Allowable Voltage Fluctuation		-10 (-15) to +10%									
	Allowable Frequency Fluctuation		±5%									
Output	Input Power (kVA)	ND Rating	4.1	5.8	9.5	14	18	26	35	43	51	
	Rated Output Capacity (kVA) <3>	ND Rating <4>	2.7	3.9	6.1	9	11	17	22	27	32	
	Rated Output Current (A)	ND Rating <4>	2.7	3.9	6.1	9	11	17	22	27	32	
	Overload Tolerance		ND Rating: 120% of rated output current for 60 s (Derating may be required for applications that start and stop frequently)									
	Carrier Frequency		User-adjustable between 1 and 15 kHz <4>					User-adjustable between 1 and 10 kHz <4>				
	Maximum Output Voltage (V)		Three-phase 500 to 600 V (proportional to input voltage)									
Maximum Output Frequency (Hz)		400 Hz (user-set)										

<1> The motor capacity (HP) refers to a NEC rated 4-pole motor. The rated output current of the drive output amps should be equal to or greater than the motor current. Select the appropriate capacity drive if operating the motor continuously above motor nameplate current.

<2> Assumes operation at the rated output current. Input current rating varies depending on the power supply transformer, input reactor, wiring connections, and power supply impedance.

<3> Rated motor capacity is calculated with a rated output voltage of 575 V.

<4> Carrier frequency default setting is Swing PWM 1 (C6-02 = 7). C6-02 settings 1, 7, 8, 9, and A do not require current derating. All other settings raise the carrier frequency and require current derating.

## ◆ Three-Phase 600 V Class Drive Models 5A0041 to 5A0099

Table A.8 Power Ratings Continued (Three-Phase 600 V Class)

Item		Specification					
Drive Models		5A0041	5A0052	5A0062	5A0077	5A0099	
Maximum Applicable Motor Capacity (HP) <1>		ND Rating	40	50	60	75	100
Input Current (A) <2>		ND Rating	44	54	66	80	108
Input	Rated Voltage Rated Frequency		Three-phase 500 to 600 Vac 50/60 Hz				
	Allowable Voltage Fluctuation		-10 (-15) to +10%				
	Allowable Frequency Fluctuation		±5%				
	Input Power (kVA)	ND Rating	50	62	75	91	123
Rated Output Capacity (kVA) <3>		ND Rating <4>	41	52	62	77	99
Rated Output Current (A)		ND Rating <4>	41	52	62	77	99
Output	Overload Tolerance		ND Rating: 120% of rated output current for 60 s (Derating may be required for applications that start and stop frequently)				
	Carrier Frequency		User-adjustable between 1 and 10 kHz <4>				User-adjustable between 1 and 8 kHz <4>
	Maximum Output Voltage (V)		Three-phase 500 to 600 V (proportional to input voltage)				
	Maximum Output Frequency (Hz)		400 Hz (user-set)				

- <1> The motor capacity (HP) refers to a NEC rated 4-pole motor. The rated output current of the drive output amps should be equal to or greater than the motor current. Select the appropriate capacity drive if operating the motor continuously above motor nameplate current.
- <2> Assumes operation at the rated output current. Input current rating varies depending on the power supply transformer, input reactor, wiring connections, and power supply impedance.
- <3> Rated motor capacity is calculated with a rated output voltage of 575 V.
- <4> Carrier frequency default setting is Swing PWM 1 (C6-02 = 7). C6-02 settings 1, 7, 8, 9, and A do not require current derating. All other settings raise the carrier frequency and require current derating.

◆ Three-Phase 600 V Class Drive Models 5A0125 to 5A0242

Table A.9 Power Ratings Continued (Three-Phase 600 V Class)

Item		Specification			
Drive Models		5A0125	5A0145	5A0192	5A0242
Maximum Applicable Motor Capacity (HP) <1>		125	150	200	250
Input Current (A) <2>		129	158	228	263
Input	Rated Voltage Rated Frequency	Three-phase 500 to 600 Vac 50/60 Hz			
	Allowable Voltage Fluctuation	-10 (-15) to +10%			
	Allowable Frequency Fluctuation	±5%			
	Input Power (kVA)	147	181	261	301
Rated Output Capacity (kVA) <3>		124	144	191	241
Rated Output Current (A)		125	145	192	242
Output	Overload Tolerance	ND Rating: 120% of rated output current for 60 s (Derating may be required for applications that start and stop frequently)			
	Carrier Frequency	User-adjustable between 1 and 3 kHz <4>			
	Maximum Output Voltage (V)	Three-phase 500 to 600 V (proportional to input voltage)			
	Maximum Output Frequency (Hz)	400 Hz (user-set)			

- <1> The motor capacity (HP) refers to a NEC rated 4-pole motor. The rated output current of the drive output amps should be equal to or greater than the motor current. Select the appropriate capacity drive if operating the motor continuously above motor nameplate current.
- <2> Assumes operation at the rated output current. Input current rating varies depending on the power supply transformer, input reactor, wiring connections, and power supply impedance.
- <3> Rated motor capacity is calculated with a rated output voltage of 575 V.
- <4> Carrier frequency default setting is Swing PWM 1 (C6-02 = 7). C6-02 settings 1, 7, 8, 9, and A do not require current derating. All other settings raise the carrier frequency and require current derating.

## A.2 Drive Specifications

- Note:**
1. Perform rotational Auto-Tuning to obtain the performance specifications given below.
  2. For optimum performance life of the drive, install the drive in an environment that meets the required specifications.

	Item	Specification
Control Characteristics	Control Method	The following control methods can be set using drive parameters: <ul style="list-style-type: none"> <li>• V/f Control (V/f)</li> <li>• Open Loop Vector Control (OLV)</li> </ul>
	Frequency Control Range	0.01 to 400 Hz
	Frequency Accuracy (Temperature Fluctuation)	Digital input: within $\pm 0.01\%$ of the max output frequency (-10 to +40 °C) Analog input: within $\pm 0.1\%$ of the max output frequency (25 °C $\pm 10$ °C)
	Frequency Setting Resolution	Digital inputs: 0.01 Hz Analog inputs: 1/2048 of the maximum output frequency setting (11 bit plus sign) Resolution of analog inputs A1 and A3 is 10 bit + sign in current mode
	Output Frequency Resolution	0.001 Hz
	Frequency Setting Signal	Main speed frequency reference: DC -10 to +10 V (20 k $\Omega$ ), DC 0 to +10 V (20 k $\Omega$ ), 4 to 20 mA (250 $\Omega$ ), 0 to 20 mA (250 $\Omega$ ) Main speed reference: Pulse train input (max. 32 kHz)
	Starting Torque </>	V/f: 150% at 3 Hz OLV: 200% at 0.3 Hz
	Speed Control Range </>	V/f: 1:40 OLV: 1:200
	Speed Control Accuracy </>	OLV: $\pm 0.2\%$ (25 °C $\pm 10$ °C)
	Speed Response </>	OLV
	Torque Limit	Parameters setting allow separate limits in four quadrants (available in OLV)
	Accel/Decel Time	0.0 to 6000.0 s (2 selectable combinations of independent acceleration and deceleration settings)
	Braking Torque	Approx. 20% (approx. 125% when using braking resistor) </> <ul style="list-style-type: none"> <li>• Short-time decel torque &lt;/&gt; : over 100% for 0.4/ 0.75 kW motors, over 50% for 1.5 kW motors, and over 20% for 2.2 kW and above motors &lt;/&gt; (overexcitation braking/High Slip Braking: approx. 40%)</li> <li>• Continuous regenerative torque: approx. 20% &lt;/&gt; (approx. 125% with dynamic braking resistor option &lt;/&gt; : 10% ED, 10s)</li> </ul>
	Braking Transistor	Models 2A0004 to 2A0138, 4A0002 to 4A0072, and 5A0003 to 5A0052 have a built-in braking transistor.
V/f Characteristics	User-selected programs and V/f preset patterns possible	
Main Control Functions	Momentary Power Loss Ride-Thru, Speed Search, Overtorque/Undertorque Detection, Torque Limit, 17 Step Speed (max), Accel/decel Switch, S-curve Accel/decel, 3-wire Sequence, Auto-tuning (rotational, stationary tuning), Dwell, Cooling Fan on/off Switch, Slip Compensation, Frequency Jump, Upper/lower Limits for Frequency Reference, DC Injection Braking at Start and Stop, Overexcitation Braking, High Slip Braking, PID Control (with sleep function), Energy Saving Control, MEMOBUS/Modbus Comm. (RS-422/RS-485 max, 115.2 kbps), Fault Restart, Application Presets, DriveWorksEZ (customized function), Removable Terminal Block with Parameter Backup Function, Online Tuning, KEB, Overexcitation Deceleration, Overvoltage Suppression, Dynamic Noise Control.	
Protection Functions	Motor Protection	Electronic thermal overload relay
	Momentary Overcurrent Protection	Drive stops when output current exceeds 170% of rated output current
	Overload Protection	Drive stops when rated output current is 120% for 60 s </>
	Overvoltage Protection	200 V class: Stops when DC bus voltage exceeds approx. 410 V 400 V class: Stops when DC bus voltage exceeds approx. 820 V 600 V class: Stops when DC bus voltage exceeds approx. 1040 V
	Undervoltage Protection	200 V class: Stops when DC bus voltage falls below approx. 190 V 400 V class: Stops when DC bus voltage falls below approx. 380 V 600 V class: Stops when DC bus voltage falls below approx. 475 V

## A.2 Drive Specifications

Item		Specification
Protection Functions	Momentary Power Loss Ride-Thru	Immediately stop after 15 ms or longer power loss <6> . Continuous operation during power loss than 2 s (standard) <7>
	Heatsink Overheat Protection	Thermistor
	Braking Resistor Overheat Protection	Overheat input signal for braking resistor (Optional ERF-type, 3% ED)
	Stall Prevention	Stall Prevention is available during acceleration, deceleration, and during run.
	Ground Protection	Electronic circuit protection <8>
	DC Bus Charge LED	Remains lit until DC bus voltage falls below 50 V
Environment	Area of Use	Indoors
	Ambient Temperature	-10 to +40 °C (IP20/NEMA 1, UL Type 1 enclosure), -10 to +50 °C (IP00/Open Type enclosure)
	Humidity	95 RH% or less (no condensation)
	Storage Temperature	-20 to +60 °C (short-term temperature during transportation)
	Altitude	Up to 1000 meters without derating, up to 3000 m with output current and voltage derating.
	Vibration/Shock	10 to 20 Hz: 9.8 m/s <sup>2</sup> <9> 20 to 55 Hz: 5.9 m/s <sup>2</sup> (2A0004 to 2A0211, 4A0002 to 4A0165, and 5A0003 to 5A0099) 2.0 m/s <sup>2</sup> (2A0250 to 2A0415, 4A0208 to 4A1200, and 5A0125 to 5A0242)
Safety Standard		UL 508C (Power Conversion), UL/cUL listed, CSA 22.2 No. 14-05 (Industrial Control Equipment), CE marked, RoHS compliant, EN 61800-5-1 (LVD), EN 61800-3 (EMC), IEC60529
Protection Design		IP00/Open Type enclosure, IP20/NEMA 1, UL Type 1 enclosure <10>

- <1> The accuracy of these values depends on motor characteristics, ambient conditions, and drive settings. Specifications may vary with different motors and with changing motor temperature. Contact Yaskawa for consultation.
- <2> Disable Stall Prevention during deceleration (L3-04 = 0) when using a regenerative converter, a regenerative unit, a braking resistor or the Braking Resistor Unit. The default setting for the Stall Prevention function will interfere with the braking resistor.
- <3> Instantaneous average deceleration torque refers to the torque required to decelerate the motor (uncoupled from the load) from the rated motor speed down to zero in the shortest time.
- <4> Actual specifications may vary depending on motor characteristics.
- <5> Overload protection may be triggered when operating with 150% of the rated output current if the output frequency is less than 6 Hz.
- <6> May be shorter due to load conditions and motor speed.
- <7> A separate Momentary Power Loss Ride-Thru Unit is required for models 2A0004 to 2A0056 and 4A0002 to 4A0031 if the application needs to continue running for up to 2 seconds during a momentary power loss.
- <8> Ground protection cannot be provided when the impedance of the ground fault path is too low, or when the drive is powered up while a ground fault is present at the output.
- <9> Models 4A0930 and 4A1200 are rated at 5.9 m/s<sup>2</sup>.
- <10> Removing the top protective cover or bottom conduit bracket from an IP20/NEMA 1, UL Type 1 enclosure drive voids NEMA 1, UL Type 1 protection while maintaining IP20 conformity. This is applicable to models 2A0004 to 2A0211, 4A0002 to 4A0165, and 5A0003 to 5A0242.

## A.3 Drive Watt Loss Data

Table A.10 Watt Loss 200 V Class Three-Phase Models

Drive Model	Normal Duty			
	Rated Amps (A) <sup>&lt;1&gt;</sup>	Heatsink Loss (W)	Interior Unit Loss (W)	Total Loss (W)
2A0004	3.5	18.4	47	66
2A0006	6.0	31	51	82
2A0008	8.0	43	52	95
2A0010	9.6	57	58	115
2A0012	12.0	77	64	141
2A0018	17.5	101	67	168
2A0021	21	138	83	222
2A0030	30	262	117	379
2A0040	40	293	145	437
2A0056	56	371	175	546
2A0069	69	491	205	696
2A0081	81	527	257	785
2A0110	110	719	286	1005
2A0138	138	842	312	1154
2A0169	169	1014	380	1394
2A0211	211	1218	473	1691
2A0250	250	1764	594	2358
2A0312	312	2020	665	2686
2A0360	360	2698	894	3591
2A0415	415	2672	954	3626

<1> Value assumes the carrier frequency is 2 kHz (C6-02 = 1, 7, 8, 9, or A).

Table A.11 Watt Loss 400 V Class Three-Phase Models

Drive Model	Normal Duty			
	Rated Amps (A) <sup>&lt;1&gt;</sup>	Heatsink Loss (W)	Interior Unit Loss (W)	Total Loss (W)
4A0002	2.1	20	48	68
4A0004	4.1	32	49	81
4A0005	5.4	45	53	97
4A0007	6.9	62	59	121
4A0009	8.8	66	60	126
4A0011	11.1	89	73	162
4A0018	17.5	177	108	285
4A0023	23	216	138	354
4A0031	31	295	161	455
4A0038	38	340	182	521
4A0044	44	390	209	599
4A0058	58	471	215	686
4A0072	72	605	265	870
4A0088	88	684	308	993
4A0103	103	848	357	1205
4A0139	139	1215	534	1749
4A0165	165	1557	668	2224
4A0208	208	1800	607	2408
4A0250	250	2379	803	3182
4A0296	296	2448	905	3353
4A0362	362	3168	1130	4298

### A.3 Drive Watt Loss Data

Drive Model	Normal Duty			
	Rated Amps (A) <1>	Heatsink Loss (W)	Interior Unit Loss (W)	Total Loss (W)
4A0414	414	3443	1295	4738
4A0515	515	4850	1668	6518
4A0675	675	4861	2037	6898
4A0930	930	8476	2952	11428
4A1200	1200	8572	3612	12184

<1> Value assumes the carrier frequency is 2 kHz (C6-02 = 1, 7, 8, 9, or A).

**Table A.12 Watt Loss Three-Phase 600 V Class Three-Phase Models**

Drive Model	Normal Duty			
	Rated Amps (A) <1>	Heatsink Loss (W)	Interior Unit Loss (W)	Total Loss (W)
5A0003	2.7	21.5	23.3	44.8
5A0004	3.9	27.5	33.6	61.1
5A0006	6.1	28.1	43.7	71.8
5A0009	9.0	43.4	68.9	112.3
5A0011	11	56.1	88.0	144.0
5A0017	17	96.6	146.7	243.2
5A0022	22	99.4	178.3	277.7
5A0027	27	132.1	227.2	359.3
5A0032	32	141.6	279.9	421.5
5A0041	41	330.8	136.2	467.0
5A0052	52	427.8	166.2	594.0
5A0062	62	791.2	279.0	1070.2
5A0077	77	959.1	329.4	1288.6
5A0099	99	1253.2	411.7	1664.9
5A0125	125	1641	537	2178
5A0145	145	1860	603	2463
5A0192	192	2420	769	3189
5A0242	242	3100	1131	4231

<1> Value assumes the carrier frequency is 2 kHz (C6-02 = 1, 7, 8, 9, or A).



## A.4 Drive Derating Data

The drive can be operated at above the rated temperature, altitude, and default carrier frequency by derating the drive capacity.

### ◆ Single-Phase Derating

iQpump1000 drives are compatible for use with both three-phase and single-phase input power supplies. The drive output to the motor is always three-phase, regardless of number of input phases.

Output capacity to the motor is derated when using single-phase input power and the drive firmware includes protection for single-phase input applications. This protection is enabled by default. Disabling this protection for single-phase input applications can void warranty and result in premature failure.

Selection of larger models always results in greater output capacity to the motor when supplying the drive with three-phase input power. However, the selection of larger models does not always yield greater output capacity when using the drive with single-phase input power.

Several factors affect the amount of derated drive output capacity when single-phase input power is supplied to the drive, such as:

- single-phase input voltage level
- motor voltage rating
- amount of input impedance.

The tables in this section assist in model selection by considering factors that affect the amount of derating in single-phase input power applications.

### ■ Single-Phase Input Sizing (Continuous Full Power)

The Output Capacity Motor FLA listed in the tables allows for a 120% overload for 60 seconds. Contact Yaskawa if assistance is needed in selecting drive models for heavy duty/single-phase applications with higher overload requirements.

**Note:** Adding more impedance than is specified will degrade performance.

#### Service Factor

When using a service factor greater than 1.15, multiply the nominal power (HP) by the service factor (SF), then select a drive with a higher power rating than the product of that equation.

**Example:** 1.5 HP x 1.3 SF = 1.95 SF HP

The user should select a 2 HP or larger drive.

**Table A.13 240 V Single-Phase Input (-5% to +10%), 230 V Three-Phase Motor**

Drive Model	Without Additional Impedance		With Additional Impedance (use either DC type or AC type)			
			Yaskawa Reactor Part Number		Motor Power (HP)	Drive Input Current (A)
	Motor Power (HP)	Drive Input Current (A)	DC Type	AC Type		
2A0004	1/3	4.3	URX000043	URX000303	1/2	4.1
2A0006	3/4	7.7	URX000043	URX000303	3/4	5.7
2A0008	1	9.5	05P00620-0113	URX000307	1	7.2
2A0010	1	9.5	05P00620-0113	URX000311	1	7.8
2A0012	1.5	13.7	URX000048	URX000316	2	13
2A0018	2	19	05P00620-0120	URX000319	3	19
2A0021	2	19	05P00620-0120	URX000323	3	19
2A0030	3	27	05P00620-0120	URX000323	3	19
2A0040	3	27	05P00620-0124	URX000323	5	30
2A0056	5	43	URX000059	URX000326	7.5	42
2A0069	7.5	62	URX000063	URX000332	10	56
2A0081	10	79	URX000072	URX000338	15	84

## A.4 Drive Derating Data

Drive Model	Without Additional Impedance		With Additional Impedance (use either DC type or AC type)			
			Yaskawa Reactor Part Number		Motor Power (HP)	Drive Input Current (A)
	Motor Power (HP)	Drive Input Current (A)	DC Type	AC Type		
2A0110	10	60	DC Link Choke Built-in	Do Not Use AC Reactor	10	60
2A0138	15	87			15	87
2A0169	20	114			20	114
2A0211	25	141			25	141
2A0250	30	167			30	167
2A0312	40	219			40	219
2A0360	50	273			50	273
2A0415	60	322			60	322

Table A.14 480 V Single-Phase Input (-5% to +10%), 460 V Three-Phase Motor

Drive Model	Without Additional Impedance		With Additional Impedance (use either DC type or AC type)			
			Yaskawa Reactor Part Number		Motor Power (HP)	Drive Input Current (A)
	Motor Power (HP)	Drive Input Current (A)	DC Type	AC Type		
4A0002	1/3	2.4	URX000041	URX000295	1/2	2.1
4A0004	3/4	4.2	URX000041	URX000299	1	3.8
4A0005	1	5.1	05P00620-0110	URX000303	1.5	5.5
4A0007	1.5	7.5	05P00652-0213	URX000308	2	6.7
4A0009	2	10	URX000048	URX000312	3	9.5
4A0011	2	10	URX000053	URX000316	3	10
4A0018	3	13.2	URX000052	URX000316	3	10
4A0023	3	14	URX000052	URX000316	5	15
4A0031	7.5	30.2	URX000055	URX000324	7.5	22
4A0038	7.5	31	05P00620-0123	URX000327	10	31
4A0044	10	38.3	URX000061	URX000327	10	28
4A0058	15	42.2	DC Link Choke Built-in	URX000332	15	41
4A0072	20	55		Do Not Use AC Reactor	20	56
4A0088	20	56		20	56	
4A0103	20	57		URX000335	20	54
4A0139	40	108		URX000341	40	104
4A0165	40	110		URX000341	40	104
4A0208	50	136		URX000347	50	130
4A0250	60	162		URX000347	60	154
4A0296	60	165		URX000350	75	192
4A0362	75	205		URX000353	100	251
4A0414	125	328		URX000356	125	314
4A0515	125	337		URX000353	125	314
4A0675	150	405		Do Not Use	150	405

Table A.15 600 V Single-Phase Input (-5% to +10%), 575 V Three-Phase Motor

Drive Model	Without Additional Impedance		With Additional Impedance (use either DC type or AC type)			
			Yaskawa Reactor Part Number		Motor Power (HP)	Drive Input Current (A)
	DC Type	AC Type				
5A0003	1	3.5	05P00620-0110	URX000303	1	3.5
5A0004	1.5	4.8	URX000044	URX000306	2	5
5A0006	2	7	05P00652-0213	URX000308	3	7.6
5A0009	3	9.5	URX000049	URX000313	5	11
5A0011	2	7.1	05P00652-0213	URX000308	3	7.7
5A0017	5	16	URX000048	URX000316	5	12
5A0022	5	16	URX000053	URX000320	7.5	18
5A0027	7.5	24	URX000055	URX000324	10	23
5A0032	7.5	24	URX000055	URX000324	10	23
5A0041	15	34	DC Link Choke Built-in	URX000326	15	32
5A0052	15	34		URX000326	15	32
5A0062	25	57		URX000335	25	54
5A0077	30	66		URX000338	30	64
5A0099	30	66		URX000338	30	64
5A0125	50	106		URX000344	50	102
5A0145	50	106		URX000344	50	102
5A0192	75	159		URX000347	75	152
5A0242	75	159		URX000347	75	152

■ Single-Phase Main Circuit Wiring and Tightening Torques

Table A.16 240 V Single-Phase Main Circuit Wiring and Tightening Torques

Drive Model	Terminal	Recomm. Gauge Without Additional Impedance <1> AWG, kcmil	Recomm. Gauge With Additional Impedance <2> AWG, kcmil	Wire Range AWG, kcmil <3>	Screw Size	Tightening Torque N·m (lb.in.)
2□0004 2□0006 2□0008 2□0010 2□0012	R/L1, S/L2	14	14	14 to 10	M4	1.2 to 1.5 (10.6 to 13.3)
	U/T1, V/T2, W/T3	14	14	14 to 10		
	ϕ, ϕ1, ϕ2	-	14	14 to 10		
	B1, B2	-	-	14 to 10		
	GND	14	14	14 to 10		
2□0018 2□0021	R/L1, S/L2	10	10	14 to 10	M4	1.2 to 1.5 (10.6 to 13.3)
	U/T1, V/T2, W/T3	14	14	14 to 10		
	ϕ, ϕ1, ϕ2	-	10	14 to 10		
	B1, B2	-	-	14 to 10		
	GND	10	10	14 to 10		
2□0030	R/L1, S/L2	10	10	12 to 6	M4	2.1 to 2.3 (18.6 to 20.4)
	U/T1, V/T2, W/T3	12	12	12 to 6		
	ϕ, ϕ1, ϕ2	-	10	12 to 6		
	B1, B2	-	-	12 to 10		
	GND	10	10	12 to 10	M5	2.0 to 2.5 (17.7 to 22.1)
2□0040	R/L1, S/L2	10	8	12 to 6	M4	2.1 to 2.3 (18.6 to 20.4)
	U/T1, V/T2, W/T3	12	12	12 to 6		
	ϕ, ϕ1, ϕ2	-	8	12 to 6		
	B1, B2	-	-	12 to 10		
	GND	10	8	12 to 10	M5	2 to 2.5 (17.7 to 22.1)

## A.4 Drive Derating Data

Drive Model	Terminal	Recomm. Gauge Without Additional Impedance <1> AWG, kcmil	Recomm. Gauge With Additional Impedance <2> AWG, kcmil	Wire Range AWG, kcmil <3>	Screw Size	Tightening Torque N·m (lb.in.)
2□0056	R/L1, S/L2	4	6	6 to 4	M6	5.4 to 6.0 (47.8 to 53.1)
	U/T1, V/T2, W/T3	6	6	6 to 4		
	⊖, ⊕1, ⊕2	-	6	6 to 4		
	B1, B2	-	-	10 to 8	M5	2 to 2.5 (17.7 to 22.1)
	GND	6	6	8 to 6	M6	5.4 to 6.0 (47.8 to 53.1)
2□0069	R/L1, S/L2	4	4	10 to 2	M8	9.9 to 11.0 (87.6 to 97.4)
	U/T1, V/T2, W/T3	10	10	10 to 2		
	⊖, ⊕1, ⊕2	-	4	10 to 2		
	B1, B2	-	-	10 to 6	M5	2 to 2.5 (17.7 to 22.1)
	GND	6	6	6 to 4	M6	5.4 to 6.0 (47.8 to 53.1)
2□0081	R/L1, S/L2	3	3	10 to 2	M8	9.9 to 11.0 (87.6 to 97.4)
	U/T1, V/T2, W/T3	10	8	10 to 2		
	⊖, ⊕1, ⊕2	-	3	10 to 2		
	B1, B2	-	-	10 to 6	M5	2 to 2.5 (17.7 to 22.1)
	GND	6	6	6 to 4	M6	5.4 to 6.0 (47.8 to 53.1)
2□0110	R/L1, S/L2	4	4	10 to 1/0	M8	9.9 to 11.0 (79.7 to 97.4)
	U/T1, V/T2, W/T3	10	10	10 to 1/0		
	⊖, ⊕1	-	-	10 to 1/0		
	B1, B2	-	-	10 to 1/0		
	GND	6	6	10 to 1/0		
2□0138	R/L1, S/L2	2	2	10 to 3/0	M10	18 to 23 (159 to 204)
	U/T1, V/T2, W/T3	8	8	10 to 3/0		
	⊖, ⊕1	-	-	10 to 3/0		
	B1, B2	-	-	10 to 3/0	M8	9 to 11 (79.7 to 97.4)
	GND	6	6	10 to 1/0		
2□0169	R/L1, S/L2	1/0	6	10 to 4/0	M10	18 to 23 (159 to 204)
	U/T1, V/T2, W/T3	1/0	6	10 to 4/0		
	⊖, ⊕1	-	-	10 to 4/0		
	⊕3	-	-	10 to 4/0		
	GND	3	3	10 to 4/0		
2□0211	R/L1, S/L2	2/0	2/0	10 to 4/0	M10	18 to 23 (159 to 204)
	U/T1, V/T2, W/T3	1/0	1/0	10 to 4/0		
	⊖, ⊕1	-	-	10 to 4/0		
	⊕3	-	-	10 to 4/0		
	GND	2	2	10 to 4/0		
2□0250	R/L1, S/L2	3/0	4/0	up to 250 kcmil	M12	32 to 40 (283 to 354)
	U/T1, V/T2, W/T3	3	3	up to 250 kcmil		
	⊖, ⊕1	-	-	up to 250 kcmil		
	⊕3	-	-	up to 250 kcmil	M10	18 to 23 (159 to 204)
	GND	1	1/0	up to 250 kcmil	M12	32 to 40 (283 to 354)
2□0312	R/L1, S/L2	1/0 X 2P	1/0 X 2P	up to 250 kcmil	M12	32 to 40 (283 to 354)
	U/T1, V/T2, W/T3	1	1	up to 250 kcmil		
	⊖, ⊕1	-	-	up to 250 kcmil		
	⊕3	-	-	up to 250 kcmil	M10	18 to 23 (159 to 204)
	GND	3/0	3/0	up to 250 kcmil	M12	32 to 40 (283 to 354)

Drive Model	Terminal	Recomm. Gauge Without Additional Impedance <1> AWG, kcmil	Recomm. Gauge With Additional Impedance <2> AWG, kcmil	Wire Range AWG, kcmil <3>	Screw Size	Tightening Torque N·m (lb.in.)
2□0360	R/L1, S/L2	2/0 X 2P	2/0 X 2P	up to 250 kcmil	M12	32 to 40 (283 to 354)
	U/T1, V/T2, W/T3	2/0	2/0	up to 250 kcmil		
	⊖, ⊕1	-	-	up to 250 kcmil		
	⊕3	-	-	up to 250 kcmil	M10	18 to 23 (159 to 204)
	GND	1 X 2P	1 X 2P	up to 250 kcmil	M12	32 to 40 (283 to 354)
2□0415	R/L1, S/L2	3/0 X 2P	3/0 X 2P	up to 250 kcmil	M12	32 to 40 (283 to 354)
	U/T1, V/T2, W/T3	3/0	3/0	up to 250 kcmil		
	⊖, ⊕1	-	-	up to 250 kcmil		
	⊕3	-	-	up to 250 kcmil	M10	18 to 23 (159 to 204)
	GND	1/0 X 2P	1/0 X 2P	up to 250 kcmil	M12	32 to 40 (283 to 354)

- <1> Refer to local codes while selecting wire size for terminals ⊖, ⊕1, ⊕2 if these terminals need to be used for other optional power devices.
- <2> The wire size recommended for terminal ⊖, ⊕1, ⊕2 is for DC type additional impedance only. See the additional impedance type recommended in [Table A.13](#) before choosing wire size for terminals ⊖, ⊕1, ⊕2.
- <3> Terminal wire range is the range of wire sizes the terminals can accept. This information is intended to keep within the wire range of the terminals while selecting a wire size for the terminals per local codes for the intended application of these terminals.

**Table A.17 480 V Single-Phase Main Circuit Wiring and Tightening Torques**

Drive Model	Terminal	Recomm. Gauge Without Additional Impedance <1> AWG, kcmil	Recomm. Gauge With Additional Impedance <2> AWG, kcmil	Wire Range AWG, kcmil <3>	Screw Size	Tightening Torque N·m (lb.in.)
4□0002 4□0004 4□0005 4□0007 4□0009 4□0011	R/L1, S/L2	14	14	14 to 10	M4	1.2 to 1.5 (10.6 to 13.3)
	U/T1, V/T2, W/T3	14	14	14 to 10		
	⊖, ⊕1, ⊕2	-	14	14 to 10		
	B1, B2	-	-	14 to 10		
	GND	14	14	14 to 10		
	4□0018	R/L1, S/L2	12	12	12 to 6	M4
U/T1, V/T2, W/T3		12	12	12 to 6		
⊖, ⊕1, ⊕2		-	12	12 to 6		
B1, B2		-	-	12 to 10		
GND		12	12	12 to 10	M5	2.0 to 2.5 (17.7 to 221.1)
4□0023	R/L1, S/L2	12	12	12 to 6	M4	2.1 to 2.3 (18.6 to 20.4)
	U/T1, V/T2, W/T3	12	12	12 to 6		
	⊖, ⊕1, ⊕2	-	12	12 to 6		
	B1, B2	-	-	12 to 10		
	GND	12	12	12 to 10	M5	2.0 to 2.5 (17.7 to 221.1)
4□0031	R/L1, S/L2	8	10	10 to 6	M5	3.6 to 4.0 (31.8 to 35.4)
	U/T1, V/T2, W/T3	10	10	10 to 6		
	⊖, ⊕1, ⊕2	-	10	10 to 6		
	B1, B2	-	-	10 to 6		
	GND	8	10	10 to 8	M6	5.4 to 6.0 (47.8 to 53.1)
4□0038	R/L1, S/L2	8	8	10 to 6	M5	3.6 to 4.0 (31.8 to 35.4)
	U/T1, V/T2, W/T3	10	10	10 to 6		
	⊖, ⊕1, ⊕2	-	10	10 to 6		
	B1, B2	-	-	10 to 6		
	GND	8	8	10 to 6	M6	5.4 to 6.0 (47.8 to 53.1)

## A.4 Drive Derating Data

Drive Model	Terminal	Recomm. Gauge Without Additional Impedance <1> AWG, kcmil	Recomm. Gauge With Additional Impedance <2> AWG, kcmil	Wire Range AWG, kcmil <3>	Screw Size	Tightening Torque N·m (lb.in.)
4□0044	R/L1, S/L2	6	6	6 to 4	M6	5.4 to 6.0 (47.8 to 53.1)
	U/T1, V/T2, W/T3	6	6	6 to 4		
	⊖, ⊕1, ⊕2	-	6	6 to 4		
	B1, B2	-	-	10 to 8	M5	2.7 to 3.0 (23.9 to 26.6)
	GND	6	6	8 to 6	M6	5.4 to 6.0 (47.8 to 53.1)
4□0058	R/L1, S/L2	8	8	10 to 1/0	M8	9 to 11 (79.7 to 97.4)
	U/T1, V/T2, W/T3	10	10	10 to 1/0		
	⊖, ⊕1, ⊕2	-	-	10 to 1/0		
	B1, B2	-	-	10 to 1/0		
	GND	8	8	10 to 1/0		
4□0072	R/L1, S/L2	4	4	10 to 1/0	M8	9 to 11 (79.7 to 97.4)
	U/T1, V/T2, W/T3	10	10	10 to 1/0		
	⊖, ⊕1, ⊕2	-	-	10 to 1/0		
	B1, B2	-	-	10 to 1/0		
	GND	6	6	10 to 1/0		
4□0088	R/L1, S/L2	4	4	6 to 250 kcmil	M8	9 to 11 (79.7 to 97.4)
	U/T1, V/T2, W/T3	6	6	6 to 250 kcmil		
	⊖, ⊕1	-	-	6 to 250 kcmil		
	⊕3	-	-	6 to 250 kcmil		
	GND	6	6	6 to 250 kcmil		
4□0103	R/L1, S/L2	4	6	6 to 250 kcmil	M8	9 to 11 (79.7 to 97.4)
	U/T1, V/T2, W/T3	6	6	6 to 250 kcmil		
	⊖, ⊕1	-	-	6 to 250 kcmil		
	⊕3	-	-	6 to 250 kcmil		
	GND	6	6	6 to 250 kcmil		
4□0139	R/L1, S/L2	1	1	10 to 4/0	M10	18 to 23 (159 to 204)
	U/T1, V/T2, W/T3	6	6	10 to 4/0		
	⊖, ⊕1	-	-	10 to 4/0		
	⊕3	-	-	10 to 4/0		
	GND	4	4	10 to 4/0		
4□0165	R/L1, S/L2	1/0	1	10 to 4/0	M10	18 to 23 (159 to 204)
	U/T1, V/T2, W/T3	6	6	10 to 4/0		
	⊖, ⊕1	-	-	10 to 4/0		
	⊕3	-	-	10 to 4/0		
	GND	3	4	10 to 4/0		
4□0208	R/L1, S/L2	2/0	2/0	up to 250 kcmil	M10	18 to 23 (159 to 204)
	U/T1, V/T2, W/T3	4	4	up to 250 kcmil		
	⊖, ⊕1	-	-	up to 250 kcmil		
	⊕3	-	-	up to 250 kcmil		
	GND	2	2	up to 250 kcmil		
4□0250	R/L1, S/L2	3/0	3/0	up to 250 kcmil	M10	18 to 23 (159 to 204)
	U/T1, V/T2, W/T3	3	3	up to 250 kcmil		
	⊖, ⊕1	-	-	up to 250 kcmil		
	⊕3	-	-	up to 250 kcmil		
	GND	1	1	up to 250 kcmil		

Drive Model	Terminal	Recomm. Gauge Without Additional Impedance <1> AWG, kcmil	Recomm. Gauge With Additional Impedance <2> AWG, kcmil	Wire Range AWG, kcmil <3>	Screw Size	Tightening Torque N·m (lb.in.)
4□0296	R/L1, S/L2	3/0	1 X 2P	up to 250 kcmil	M12	32 to 40 (283 to 354)
	U/T1, V/T2, W/T3	3	2	upto 250 kcmil		
	⊖, ⊕1	-	-	up to 250 kcmil		
	⊕3	-	-	up to 250 kcmil	M10	
	GND	1	2/0	up to 250 kcmil	M12	
4□0362	R/L1, S/L2	1 X 2P	2/0 X 2P	up to 250 kcmil	M12	32 to 40 (283 to 354)
	U/T1, V/T2, W/T3	1	1/0	up to 250 kcmil		
	⊖, ⊕1	-	-	up to 250 kcmil		
	⊕3	-	-	up to 250 kcmil	M10	
	GND	2/0	3/0	up to 250 kcmil	M12	
4□0414	R/L1, S/L2	3/0 X 2P	3/0 X 2P	up to 250 kcmil	M12	32 to 40 (283 to 354)
	U/T1, V/T2, W/T3	3/0	3/0	up to 250 kcmil		
	⊖, ⊕1	-	-	up to 250 kcmil		
	⊕3	-	-	up to 250 kcmil		
	GND	1/0 X 2P	1/0 X 2P	up to 250 kcmil		
4□0515	R/L1, S/L2	4/0 X 2P	3/0 X 2P	up to 250 kcmil	M12	32 to 40 (283 to 354)
	U/T1, V/T2, W/T3	3/0	3/0	up to 250 kcmil		
	⊖, ⊕1	-	-	up to 250 kcmil		
	⊕3	-	-	up to 250 kcmil		
	GND	1/0 X 2P	1/0 X 2P	up to 250 kcmil		
4□0675	R/L1, S/L2	1 X 4P	1 X 4P	up to 250 kcmil	M12	32 to 40 (283 to 354)
	U/T1, V/T2, W/T3	4/0	4/0	up to 250 kcmil		
	⊖, ⊕1	-	-	up to 250 kcmil		
	⊕3	-	-	up to 250 kcmil		
	GND	3/0 X 2P	3/0 X 2P	up to 250 kcmil		

- <1> Refer to local codes while selecting wire size for terminals ⊖, ⊕1, ⊕2 if these terminals need to be used for other optional power devices.
- <2> The wire size recommended for terminal ⊖, ⊕1, ⊕2 is for DC type additional impedance only. See the additional impedance type recommended in [Table A.14](#) before choosing wire size for terminals ⊖, ⊕1, ⊕2.
- <3> Terminal wire range is the range of wire sizes the terminals can accept. This information is intended to keep within the wire range of the terminals while selecting a wire size for the terminals per local codes for the intended application of these terminals.

**Table A.18 600 V Single-Phase Main Circuit Wiring and Tightening Torques**

Drive Model	Terminal	Recomm. Gauge Without Additional Impedance <1> AWG, kcmil	Recomm. Gauge With Additional Impedance <2> AWG, kcmil	Wire Range AWG, kcmil <3>	Screw Size	Tightening Torque N·m (lb.in.)
5□0003 5□0004 5□0006 5□0009	R/L1, S/L2	14	14	14 to 10	M4	1.2 to 1.5 (10.6 to 13.3)
	U/T1, V/T2, W/T3	14	14	14 to 10		
	⊖, ⊕1, ⊕2	-	14	14 to 10		
	B1, B2	-	-	14 to 10		
	GND	14	14	14 to 10		
5□0011	R/L1, S/L2	12	12	12 to 6	M4	2.1 to 2.3 (18.6 to 20.4)
	U/T1, V/T2, W/T3	12	12	12 to 6		
	⊖, ⊕1, ⊕2	-	12	12 to 6		
	B1, B2	-	-	12 to 10		
	GND	12	12	12 to 10	M5	2.0 to 2.5 (17.7 to 22.1)

Specifications

**A**

## A.4 Drive Derating Data

Drive Model	Terminal	Recomm. Gauge Without Additional Impedance <1> AWG, kcmil	Recomm. Gauge With Additional Impedance <2> AWG, kcmil	Wire Range AWG, kcmil <3>	Screw Size	Tightening Torque N·m (lb.in.)
5□0017	R/L1, S/L2	10	10	10 to 6	M5	3.6 to 4.0 (31.8 to 35.4)
	U/T1, V/T2, W/T3	10	10	10 to 6		
	⊖, ⊕1, ⊕2	-	10	10 to 6		
	B1, B2	-	-	10 to 6		
	GND	10	10	10 to 8	M6	
5□0022	R/L1, S/L2	10	10	10 to 6	M5	3.6 to 4.0 (31.8 to 35.4)
	U/T1, V/T2, W/T3	10	10	10 to 6		
	⊖, ⊕1, ⊕2	-	10	10 to 6		
	B1, B2	-	-	10 to 6		
	GND	10	10	10 to 8	M6	
5□0027 5□0032	R/L1, S/L2	6	6	6 to 4	M6	5.4 to 6.0 (47.8 to 53.1)
	U/T1, V/T2, W/T3	6	6	6 to 4		
	⊖, ⊕1, ⊕2	-	6	6 to 4	M5	
	B1, B2	-	-	10 to 8		
	GND	6	6	8 to 6		
5□0041 5□0052	R/L1, S/L2	8	8	10 to 1/0	M8	9 to 11 (79.7 to 97.4)
	U/T1, V/T2, W/T3	10	10	10 to 1/0		
	⊖, ⊕1, ⊕2	-	-	10 to 1/0		
	B1, B2	-	-	10 to 1/0		
	GND	8	8	10 to 1/0		
5□0062	R/L1, S/L2	6	6	10 to 4/0	M10	18 to 23 (159 to 204)
	U/T1, V/T2, W/T3	10	10	10 to 4/0		
	⊖, ⊕1	-	-	10 to 4/0		
	⊕3	-	-	10 to 4/0		
	GND	6	6	10 to 4/0		
5□0077 5□0099	R/L1, S/L2	4	4	10 to 4/0	M10	18 to 23 (159 to 204)
	U/T1, V/T2, W/T3	8	8	10 to 4/0		
	⊖, ⊕1	-	-	10 to 4/0		
	⊕3	-	-	10 to 4/0		
	GND	4	4	10 to 4/0		
5□0125	R/L1, S/L2	1	1	up to 250 kcmil	M10	18 to 23 (159 to 204)
	U/T1, V/T2, W/T3	6	6	up to 250 kcmil		
	⊖, ⊕1	-	-	up to 250 kcmil		
	⊕3	-	-	up to 250 kcmil		
	GND	1	1	up to 250 kcmil		
5□0145	R/L1, S/L2	1	1	up to 250 kcmil	M10	18 to 23 (159 to 204)
	U/T1, V/T2, W/T3	6	6	up to 250 kcmil		
	⊖, ⊕1	-	-	up to 250 kcmil		
	⊕3	-	-	up to 250 kcmil		
	GND	1	1	up to 250 kcmil		
5□0192	R/L1, S/L2	3/0	3/0	up to 250 kcmil	M12	32 to 40 (283 to 354)
	U/T1, V/T2, W/T3	3	3	up to 250 kcmil		
	⊖, ⊕1	-	-	up to 250 kcmil	M10	
	⊕3	-	-	up to 250 kcmil		
	GND	1	1	up to 250 kcmil		



Drive Model	Terminal	Recomm. Gauge Without Additional Impedance <1> AWG, kcmil	Recomm. Gauge With Additional Impedance <2> AWG, kcmil	Wire Range AWG, kcmil <3>	Screw Size	Tightening Torque N·m (lb.in.)
5□0242	R/L1, S/L2	3/0	3/0	up to 250 kcmil	M12	32 to 40 (283 to 354)
	U/T1, V/T2, W/T3	3	3	up to 250 kcmil		
	⊖, ⊕1	-	-	up to 250 kcmil		
	⊕3	-	-	up to 250 kcmil	M10	18 to 23 (159 to 204)
	GND	1	1	up to 250 kcmil	M12	32 to 40 (283 to 354)

- <1> Refer to local codes while selecting wire size for terminals ⊖, ⊕1, ⊕2 if these terminals need to be used for other optional power devices.
- <2> The wire size recommended for terminal ⊖, ⊕1, ⊕2 is for DC type additional impedance only. See the additional impedance type recommended in [Table A.15](#) before choosing wire size for terminals ⊖, ⊕1, ⊕2.
- <3> Terminal wire range is the range of wire sizes the terminals can accept. This information is intended to keep within the wire range of the terminals while selecting a wire size for the terminals per local codes for the intended application of these terminals.

### ■ Single-Phase Closed-Loop Crimp Terminal Sizes

Table A.19 Panduit Closed-Loop Crimp Terminal Size Single-Phase w/o Additional Impedance

Drive Model	Terminal	Recomm. Gauge Without Additional Impedance AWG, kcmil	Screw Size	Panduit Ring Terminal (non-insulated)	Panduit Recomm. Installation Tool	Panduit Crimphead / Die Part No.	Insulation Cap Model No.
2□0004 2□0006 2□0008 2□0010 2□0012	R/L1, S/L2	14	M4	P14-8R	CT-1570	-	TP-003
	U/T1, V/T2, W/T3	14					
2□0018 2□0021	R/L1, S/L2	10	M4	P10-8R	CT-1570	-	TP-005
	U/T1, V/T2, W/T3	14		P14-8R			TP-003
2□0030	R/L1, S/L2	10	M4	P10-8R	CT-1570	-	TP-005
	U/T1, V/T2, W/T3	12					
2□0040	R/L1, S/L2	10	M4	P10-8R	CT-1570	-	TP-005
	U/T1, V/T2, W/T3	12					
2□0056	R/L1, S/L2	4	M6	P4-14R	CT-1701	-	TP-022
	U/T1, V/T2, W/T3	6		P6-14R			TP-014
2□0069	R/L1, S/L2	4	M8	P4-56R	CT-1701	-	TP-022
	U/T1, V/T2, W/T3	10		P10-56R			TP-005
2□0081	R/L1, S/L2	3	M8	P2-56R	CT-1701	-	TP-038
	U/T1, V/T2, W/T3	10		P10-56R			TP-005
2□0110	R/L1, S/L2	4	M8	P4-56R	CT-1701	-	TP-022
	U/T1, V/T2, W/T3	10		P10-56R			TP-005
2□0138	R/L1, S/L2	2	M10	P2-38R	CT-1701	-	TP-038
	U/T1, V/T2, W/T3	8		P8-38R			TP-008
2□0169	R/L1, S/L2	1/0	M10	S1/0-38R-X	CT-720	CD-720-2	TP-060
	U/T1, V/T2, W/T3	6		S6-38R-E		CD-720-1	TP-014
2□0211	R/L1, S/L2	2/0	M10	S2/0-38R	CT-720	CD-720-2	TP-060
	U/T1, V/T2, W/T3	1/0		S1/0-38R			TP-038
2□0250	R/L1, S/L2	3/0	M12	S3/0-12R-5	CT-720	CD-720-2	TP-080
	U/T1, V/T2, W/T3	3		S2-12R-X			TP-038
2□0312	R/L1, S/L2	1/0 X 2P	M12	S1/0-12R-X (Qty. 2)	CT-720	CD-720-2	TP-038 (Qty. 2)
	U/T1, V/T2, W/T3	1		S2-12R-X			TP-060
2□0360	R/L1, S/L2	2/0 X 2P	M12	S2/0-12R-X (Qty. 2)	CT-720	CD-720-2	TP-080 (Qty. 2)
	U/T1, V/T2, W/T3	2/0		S2/0-12R-X			TP-080

## A.4 Drive Derating Data

Drive Model	Terminal	Recomm. Gauge Without Additional Impedance AWG, kcmil	Screw Size	Panduit Ring Terminal (non-insulated)	Panduit Recomm. Installation Tool	Panduit Crimphead / Die Part No.	Insulation Cap Model No.
2□0415	R/L1, S/L2	3/0 X 2P	M12	S3/0-12R-5 (Qty. 2)	CT-720	CD-720-2	TP-080 (Qty. 2)
	U/T1, V/T2, W/T3	3/0		S3/0-12R-5			TP-080

**Table A.20 JST Closed-Loop Crimp Terminal Size Single-Phase w/o Additional Impedance**

Drive Model	Terminal	Recomm. Gauge Without Additional Impedance AWG, kcmil	Screw Size	JST Ring Terminal (non-insulated)	JST Recomm. Installation Tool	JST Crimphead / Die Part No.	Insulation Cap Model No.
2□0004 2□0006 2□0008 2□0010 2□0012	R/L1, S/L2	14	M4	R2-4	YA-4	AD-900	TP-003
	U/T1, V/T2, W/T3	14					
2□0018 2□0021	R/L1, S/L2	10	M4	R5.5-4	YA-4	AD-900	TP-005
	U/T1, V/T2, W/T3	14		R2-4			TP-003
2□0030	R/L1, S/L2	10	M4	R5.5-4	YA-4	AD-900	TP-005
	U/T1, V/T2, W/T3	12					
2□0040	R/L1, S/L2	10	M4	R5.5-4	YA-4	AD-900	TP-005
	U/T1, V/T2, W/T3	12					
2□0056	R/L1, S/L2	4	M6	R22-6	YA-5	AD-953	TP-022
	U/T1, V/T2, W/T3	6		R14-6		AD-952	TP-014
2□0069	R/L1, S/L2	4	M8	R22-8	YA-5	AD-953	TP-022
	U/T1, V/T2, W/T3	10		R5.5-8		YA-4	AD-900
2□0081	R/L1, S/L2	3	M8	R38-8	YA-5	AD-954	TP-038
	U/T1, V/T2, W/T3	10		R5.5-8		YA-4	AD-900
2□0110	R/L1, S/L2	4	M8	R22-8	YA-5	AD-953	TP-022
	U/T1, V/T2, W/T3	10		R5.5-8		YA-4	AD-900
2□0138	R/L1, S/L2	2	M10	R38-10	YA-5	AD-954	TP-038
	U/T1, V/T2, W/T3	8		R8-10		AD-951	TP-008
2□0169	R/L1, S/L2	1/0	M10	R60-10	YA-5	AD-955	TP-060
	U/T1, V/T2, W/T3	6		R14-10		AD-952	TP-014
2□0211	R/L1, S/L2	2/0	M10	70-10	YF-1 YET-300-1	TD-323, TD-312	TP-080
	U/T1, V/T2, W/T3	1/0		R60-10	YA-5	AD-955	TP-060
2□0250	R/L1, S/L2	3/0	M12	80-L12	YF-1 YET-300-1	TD-323, TD-312	TP-080
	U/T1, V/T2, W/T3	3		R38-12	YA-5	AD-954	TP-038
2□0312	R/L1, S/L2	1/0 X 2P	M12	R60-14 (Qty. 2)	YA-5	AD-955	TP-060 (Qty. 2)
	U/T1, V/T2, W/T3	1		R38-14		AD-954	TP-038
2□0360	R/L1, S/L2	2/0 X 2P	M12	70-14 (Qty. 2)	YF-1 YET-300-1	TD-323, TD-312	TP-080 (Qty. 2)
	U/T1, V/T2, W/T3	2/0		70-14		TP-080	
2□0415	R/L1, S/L2	3/0 X 2P	M12	80-L12 (Qty. 2)	YF-1 YET-300-1	TD-323 TD-312	TP-080 (Qty. 2)
	U/T1, V/T2, W/T3	3/0		80-L12		TP-080	

Table A.21 Panduit Closed-Loop Crimp Terminal Size Single-Phase w/o Additional Impedance

Drive Model	Terminal	Recomm. Gauge Without Additional Impedance AWG, kcmil	Screw Size	Panduit Ring Terminal (non-insulated)	Panduit Recomm. Installation Tool	Panduit Crimphead / Die Part No.	Insulation Cap Model No.
4□0002 4□0004 4□0005 4□0007 4□0009 4□0011	R/L1, S/L2	14	M4	P14-8R	CT-1570	-	TP-003
	U/T1, V/T2, W/T3	14					
4□0018	R/L1, S/L2	12	M4	P10-8R	CT-1570	-	TP-005
	U/T1, V/T2, W/T3	12					
4□0023	R/L1, S/L2	12	M4	P10-8R	CT-1570	-	TP-005
	U/T1, V/T2, W/T3	12					
4□0031	R/L1, S/L2	8	M5	P8-10R	CT-1701	-	TP-008
	U/T1, V/T2, W/T3	10		P10-10R			TP-005
4□0038	R/L1, S/L2	8	M5	P8-10R	CT-1701	-	TP-008
	U/T1, V/T2, W/T3	10		P10-10R			TP-005
4□0044	R/L1, S/L2	6	M6	P6-14R	CT-1701	-	TP-014
	U/T1, V/T2, W/T3	6					
4□0058	R/L1, S/L2	8	M8	P8-56R	CT-1701	-	TP-008
	U/T1, V/T2, W/T3	10		P10-56R			TP-005
4□0072	R/L1, S/L2	4	M8	P4-56R	CT-1701	-	TP-022
	U/T1, V/T2, W/T3	10		P10-56R			TP-005
4□0088	R/L1, S/L2	4	M8	P4-56R	CT-1701	-	TP-022
	U/T1, V/T2, W/T3	6		P6-56R			TP-014
4□0103	R/L1, S/L2	4	M8	P4-56R	CT-1701	-	TP-022
	U/T1, V/T2, W/T3	6		P6-56R			TP-014
4□0139	R/L1, S/L2	1	M10	S2-38R	CT-720	CD-720-2	TP-060
	U/T1, V/T2, W/T3	6		S6-38R		CD-720-1	TP-014
4□0165	R/L1, S/L2	1/0	M10	S1/0-38R	CT-720	CD-720-2	TP-060
	U/T1, V/T2, W/T3	6		S6-38R		CD-720-1	TP-014
4□0208	R/L1, S/L2	2/0	M10	S2/0-38R	CT-720	CD-720-2	TP-080
	U/T1, V/T2, W/T3	4		S4-38R		CD-720-1	TP-022
4□0250	R/L1, S/L2	3/0	M10	S3/0-38R	CT-720	CD-720-2	TP-080
	U/T1, V/T2, W/T3	3		S2-38R-X			TP-038
4□0296	R/L1, S/L2	3/0	M12	S3/0-12R-5	CT-720	CD-720-2	TP-080
	U/T1, V/T2, W/T3	3		S2-12R-X			TP-038
4□0362	R/L1, S/L2	1 X 2P	M12	S2-12R-X (Qty. 2)	CT-720	CD-720-2	TP-038 (Qty. 2)
	U/T1, V/T2, W/T3	1		S2-12R-X			TP-038
4□0414	R/L1, S/L2	3/0 X 2P	M12	S3/0-12R-5 (QTY. 2)	CT-720	CD-720-2	TP-080 (Qty. 2)
	U/T1, V/T2, W/T3	3/0		S3/0-12R-5			TP-080
4□0515	R/L1, S/L2	4/0 X 2P	M12	S4/0-12R-5 (QTY. 2)	CT-720	CD-720-3	TP-100 (Qty. 2)
	U/T1, V/T2, W/T3	3/0		S3/0-12R-5		CD-720-2	TP-080
4□0675	R/L1, S/L2	1 X 4P	M12	S2-12R-X (QTY. 4)	CT-720	CD-720-2	TP-038 (Qty. 4)
	U/T1, V/T2, W/T3	4/0		S4/0-12R-5		CD-720-3	TP-100

Specifications

**A**

## A.4 Drive Derating Data

Table A.22 JST Closed-Loop Crimp Terminal Size Single-Phase w/o Additional Impedance

Drive Model	Terminal	Recomm. Gauge Without Additional Impedance AWG, kcmil	Screw Size	JST Ring Terminal (non-insulated)	JST Recomm. Installation Tool	JST Crimphead / Die Part No.	Insulation Cap Model No.
4□0002 4□0004 4□0005 4□0007 4□0009 4□0011	R/L1, S/L2 U/T1, V/T2, W/T3	14 14	M4	R2-4	YA-4	AD-900	TP-003
4□0018	R/L1, S/L2 U/T1, V/T2, W/T3	12 12	M4	R5.5-4	YA-4	AD-900	TP-005
4□0023	R/L1, S/L2 U/T1, V/T2, W/T3	12 12	M4	R5.5-4	YA-4	AD-900	TP-005
4□0031	R/L1, S/L2 U/T1, V/T2, W/T3	8 10	M5	R8-5 R5.5-5	YA-4	AD-901 AD-900	TP-008 TP-005
4□0038	R/L1, S/L2 U/T1, V/T2, W/T3	8 10	M5	R8-5 R5.5-5	YA-4	AD-901 AD-900	TP-008 TP-005
4□0044	R/L1, S/L2 U/T1, V/T2, W/T3	6 6	M6	R14-6	YA-5	AD-952	TP-014
4□0058	R/L1, S/L2 U/T1, V/T2, W/T3	8 10	M8	R8-8 R5.5-8	YA-4	AD-901 AD-900	TP-008 TP-005
4□0072	R/L1, S/L2 U/T1, V/T2, W/T3	4 10	M8	R22-8 R5.5-8	YA-5 YA-4	AD-953 AD-900	TP-022 TP-005
4□0088	R/L1, S/L2 U/T1, V/T2, W/T3	4 6	M8	R22-8 R14-8	YA-5 YA-5	AD-953 AD-952	TP-022 TP-014
4□0103	R/L1, S/L2 U/T1, V/T2, W/T3	4 6	M8	R22-8 R14-8	YA-5 YA-5	AD-953 AD-952	TP-022 TP-014
4□0139	R/L1, S/L2 U/T1, V/T2, W/T3	1 6	M10	R38-10 R14-10	YA-5	AD-954 AD-952	TP-060 TP-014
4□0165	R/L1, S/L2 U/T1, V/T2, W/T3	1/0 6	M10	R60-10 R14-10	YA-5	AD-955 AD-952	TP-060 TP-014
4□0208	R/L1, S/L2 U/T1, V/T2, W/T3	2/0 4	M10	70-10 R22-10	YF-1 YA-5 YET-300-1	TD-323, TD-312 AD-953	TP-080 TP-022
4□0250	R/L1, S/L2 U/T1, V/T2, W/T3	3/0 3	M10	80-10 R38-10	YF-1 YET-300-1	TD-323, TD-312 TD-321, TD-311	TP-080 TP-060
4□0296	R/L1, S/L2 U/T1, V/T2, W/T3	3/0 3	M12	80-L12 R38-12	YF-1 YA-5 YET-300-1	TD-323, TD-312 AD-954	TP-080 TP-038
4□0362	R/L1, S/L2 U/T1, V/T2, W/T3	1 X 2P 1	M12	R38-12 (Qty. 2) R38-12	YA-5	AD-954	TP-038 (Qty. 2) TP-038
4□0414	R/L1, S/L2 U/T1, V/T2, W/T3	3/0 X 2P 3/0	M12	80-L12 (Qty. 2) 80-L12	YF-1 YET-300-1	TD-323 TD-312	TP-080 (Qty. 2) TP-080
4□0515	R/L1, S/L2 U/T1, V/T2, W/T3	4/0 X 2P 3/0	M12	100-L12 (Qty. 2) 80-L12	YF-1 YET-300-1	TD-324 TD-312 TD-323, TD-312	TP-100 TP-080
4□0675	R/L1, S/L2 U/T1, V/T2, W/T3	1 X 4P 4/0	M12	R38-12 (Qty. 4) 100-L12	YA-5 YF-1 YET-300-1	AD-954 TD-324, TD-312	TP-038 (Qty. 4) TP-100

Table A.23 Panduit Closed-Loop Crimp Terminal Size Single-Phase w/o Additional Impedance

Drive Model	Terminal	Recomm. Gauge Without Additional Impedance AWG, kcmil	Screw Size	Panduit Ring Terminal (non-insulated)	Panduit Recomm. Installation Tool	Panduit Crimphead / Die Part No.	Insulation Cap Model No.
5□0003 5□0004 5□0006 5□0009	R/L1, S/L2	14	M4	P14-8R	CT-1570	-	TP-003
	U/T1, V/T2, W/T3	14					
5□0011	R/L1, S/L2	12	M4	P10-8R	CT-1570	-	TP-005
	U/T1, V/T2, W/T3	12					
5□0017	R/L1, S/L2	10	M5	P10-10R	CT-1701	-	TP-005
	U/T1, V/T2, W/T3	10					
5□0022	R/L1, S/L2	10	M5	P10-10R	CT-1701	-	TP-005
	U/T1, V/T2, W/T3	10					
5□0027 5□0032	R/L1, S/L2	6	M6	P6-14R	CT-1701	-	TP-014
	U/T1, V/T2, W/T3	6					
5□0041 5□0052	R/L1, S/L2	8	M8	P8-56R	CT-1701	-	TP-008
	U/T1, V/T2, W/T3	10		P10-56R			TP-005
5□0062	R/L1, S/L2	6	M10	P6-38R	CT-1701	-	TP-014
	U/T1, V/T2, W/T3	10		P10-38R			TP-005
5□0077 5□0099	R/L1, S/L2	4	M10	S4-38R	CT-720	CD-720-1	TP-022
	U/T1, V/T2, W/T3	8		S8-38R			TP-008
5□0125	R/L1, S/L2	1	M10	S2-38R	CT-720	CD-720-2	TP-060
	U/T1, V/T2, W/T3	6		S6-38R		CD-720-1	TP-014
5□0145	R/L1, S/L2	1	M10	S2-38R	CT-720	CD-720-2	TP-060
	U/T1, V/T2, W/T3	6		S6-38R		CD-720-1	TP-014
5□0192	R/L1, S/L2	3/0	M12	S3/0-12R-5	CT-720	CD-720-2	TP-080
	U/T1, V/T2, W/T3	3		S2-12R-X			TP-038
5□0242	R/L1, S/L2	3/0	M12	S3/0-12R-5	CT-720	CD-720-2	TP-080
	U/T1, V/T2, W/T3	3		S2-12R-X			TP-038

Table A.24 JST Closed-Loop Crimp Terminal Size Single-Phase w/o Additional Impedance

Drive Model	Terminal	Recomm. Gauge Without Additional Impedance AWG, kcmil	Screw Size	JST Ring Terminal (non-insulated)	JST Recomm. Installation Tool	JST Crimphead / Die Part No.	Insulation Cap Model No.
5□0003 5□0004 5□0006 5□0009	R/L1, S/L2	14	M4	R2-4	YA-4	AD-900	TP-003
	U/T1, V/T2, W/T3	14					
5□0011	R/L1, S/L2	12	M4	R5.5-4	YA-4	AD-900	TP-005
	U/T1, V/T2, W/T3	12					
5□0017	R/L1, S/L2	10	M5	R5.5-5	YA-4	AD-900	TP-005
	U/T1, V/T2, W/T3	10					
5□0022	R/L1, S/L2	10	M5	R5.5-5	YA-4	AD-900	TP-005
	U/T1, V/T2, W/T3	10					
5□0027 5□0032	R/L1, S/L2	6	M6	R14-6	YA-5	AD-952	TP-014
	U/T1, V/T2, W/T3	6					
5□0041 5□0052	R/L1, S/L2	8	M8	R8-8	YA-4	AD-901	TP-008
	U/T1, V/T2, W/T3	10		R5.5-8		AD-900	TP-005
5□0062	R/L1, S/L2	6	M10	R14-10	YA-5	AD-952	TP-014
	U/T1, V/T2, W/T3	10		R5.5-10		AD-900	TP-005

Specifications

**A**

## A.4 Drive Derating Data

Drive Model	Terminal	Recomm. Gauge Without Additional Impedance AWG, kcmil	Screw Size	JST Ring Terminal (non-insulated)	JST Recomm. Installation Tool	JST Crimphead / Die Part No.	Insulation Cap Model No.
5□0077 5□0099	R/L1, S/L2	4	M10	R22-10	YA-5	AD-953	TP-022
	U/T1, V/T2, W/T3	8		R8-10		AD-951	TP-008
5□0125	R/L1, S/L2	1	M10	R38-10	YA-5	AD-954	TP-038
	U/T1, V/T2, W/T3	6		R14-10		AD-952	TP-014
5□0145	R/L1, S/L2	1	M10	R38-10	YA-5	AD-954	TP-038
	U/T1, V/T2, W/T3	6		R14-10		AD-952	TP-014
5□0192	R/L1, S/L2	3/0	M12	80-L12	YF-1 YET-300-1	TD-323, TD-312	TP-080
	U/T1, V/T2, W/T3	3		R38-12	YA-5	AD-954	TP-038
5□0242	R/L1, S/L2	3/0	M12	80-L12	YF-1 YET-300-1	TD-323, TD-312	TP-080
	U/T1, V/T2, W/T3	3		R38-12	YA-5	AD-954	TP-038

**Table A.25 Panduit Closed-Loop Crimp Terminal Size Single-Phase With Additional Impedance**

Drive Model	Terminal	Recomm. Gauge With Additional Impedance AWG, kcmil	Screw Size	Panduit Ring Terminal (non-insulated)	Panduit Recomm. Installation Tool	Panduit Crimphead / Die Part No.	Insulation Cap Model No.
2□0004 2□0006 2□0008 2□0010 2□0012	R/L1, S/L2	14	M4	P14-8R	CT-1570	-	TP-003
	U/T1, V/T2, W/T3	14					
2□0018 2□0021	R/L1, S/L2	10	M4	P10-8R	CT-1570	-	TP-005
	U/T1, V/T2, W/T3	14		P14-8R			TP-003
2□0030	R/L1, S/L2	10	M4	P10-8R	CT-1570	-	TP-005
	U/T1, V/T2, W/T3	12					
2□0040	R/L1, S/L2	8	M4	P8-8R	CT-1701	-	TP-008
	U/T1, V/T2, W/T3	12		P10-8R			TP-005
2□0056	R/L1, S/L2	6	M6	P6-14R	CT-1701	-	TP-014
	U/T1, V/T2, W/T3	6					
2□0069	R/L1, S/L2	4	M8	P4-56R	CT-1701	-	TP-022
	U/T1, V/T2, W/T3	10		P10-56R			TP-005
2□0081	R/L1, S/L2	3	M8	P2-56R	CT-1701	-	TP-038
	U/T1, V/T2, W/T3	8		P8-56R			TP-008
2□0110	R/L1, S/L2	4	M8	P4-56R	CT-1701	-	TP-022
	U/T1, V/T2, W/T3	10		P10-56R			TP-005
2□0138	R/L1, S/L2	2	M10	P2-38R	CT-1701	-	TP-038
	U/T1, V/T2, W/T3	8		P8-38R			TP-008
2□0169	R/L1, S/L2	1/0	M10	S1/0-38R-X	CT-720	CD-720-2	TP-060
	U/T1, V/T2, W/T3	6		S6-38R-E		CD-720-1	TP-014
2□0211	R/L1, S/L2	2/0	M10	S2/0-38R	CT-720	CD-720-2	TP-060
	U/T1, V/T2, W/T3	1/0		S1/0-38R			TP-038
2□0250	R/L1, S/L2	4/0	M12	S4/0-12R-5	CT-720	CD-720-2	TP-100
	U/T1, V/T2, W/T3	3		S2-12R-X		CD720-3	TP-038
2□0312	R/L1, S/L2	1/0 X 2P	M12	S1/0-12R-X (Qty. 2)	CT-720	CD-720-2	TP-038 (Qty. 2)
	U/T1, V/T2, W/T3	1		S2-12R-X			TP-060
2□0360	R/L1, S/L2	2/0 X 2P	M12	S2/0-12R-X (Qty. 2)	CT-720	CD-720-2	TP-080 (Qty. 2)
	U/T1, V/T2, W/T3	2/0		S2/0-12R-X			TP-080

Drive Model	Terminal	Recomm. Gauge With Additional Impedance AWG, kcmil	Screw Size	Panduit Ring Terminal (non-insulated)	Panduit Recomm. Installation Tool	Panduit Crimphead / Die Part No.	Insulation Cap Model No.
2□0415	R/L1, S/L2	3/0 X 2P	M12	S3/0-12R-5 (Qty. 2)	CT-720	CD-720-2	TP-080 (Qty. 2)
	U/T1, V/T2, W/T3	3/0		S3/0-12R-5			TP-080

Table A.26 JST Closed-Loop Crimp Terminal Size Single-Phase With Additional Impedance

Drive Model	Terminal	Recomm. Gauge With Additional Impedance AWG, kcmil	Screw Size	JST Ring Terminal (non-insulated)	JST Recomm. Installation Tool	JST Crimphead / Die Part No.	Insulation Cap Model No.
2□0004 2□0006 2□0008 2□0010 2□0012	R/L1, S/L2	14	M4	R2-4	YA-4	AD-900	TP-003
	U/T1, V/T2, W/T3	14					
2□0018 2□0021	R/L1, S/L2	10	M4	R5.5-4	YA-4	AD-900	TP-005
	U/T1, V/T2, W/T3	14		R2-4			TP-003
2□0030	R/L1, S/L2	10	M4	R5.5-4	YA-4	AD-900	TP-005
	U/T1, V/T2, W/T3	12					
2□0040	R/L1, S/L2	8	M4	8-4	YA-4	AD-901	TP-008
	U/T1, V/T2, W/T3	12		R5.5-4		AD-900	TP-005
2□0056	R/L1, S/L2	6	M6	R14-6	YA-5	AD-952	TP-014
	U/T1, V/T2, W/T3	6					
2□0069	R/L1, S/L2	4	M8	R22-8	YA-5	AD-953	TP-022
	U/T1, V/T2, W/T3	10		R5.5-8		AD-900	TP-005
2□0081	R/L1, S/L2	3	M8	R38-8	YA-5	AD-954	TP-038
	U/T1, V/T2, W/T3	8		R8-8		AD-951	TP-008
2□0110	R/L1, S/L2	4	M8	R22-8	YA-5	AD-953	TP-022
	U/T1, V/T2, W/T3	10		R5.5-8		AD-900	TP-005
2□0138	R/L1, S/L2	2	M10	R38-10	YA-5	AD-954	TP-038
	U/T1, V/T2, W/T3	8		R8-10		AD-951	TP-008
2□0169	R/L1, S/L2	1/0	M10	R60-10	YA-5	AD-955	TP-060
	U/T1, V/T2, W/T3	6		R14-10		AD-952	TP-014
2□0211	R/L1, S/L2	2/0	M10	70-10	YF-1 YET-300-1	TD-323, TD-312	TP-080
	U/T1, V/T2, W/T3	1/0		R60-10	YA-5	AD-955	TP-060
2□0250	R/L1, S/L2	4/0	M12	100-L12	YF-1 YET-300-1	TD-324, TD-312	TP-100
	U/T1, V/T2, W/T3	3		R38-14	YA-5	AD-954	TP-038
2□0312	R/L1, S/L2	1/0 X 2P	M12	R60-14 (Qty. 2)	YA-5	AD-955	TP-060 (Qty. 2)
	U/T1, V/T2, W/T3	1		R38-14		AD-954	TP-038
2□0360	R/L1, S/L2	2/0 X 2P	M12	70-14 (Qty. 2)	YF-1 YET-300-1	TD-323, TD-312	TP-080 (Qty. 2)
	U/T1, V/T2, W/T3	2/0		70-14			TP-080
2□0415	R/L1, S/L2	3/0 X 2P	M12	80-L12 (Qty. 2)	YF-1 YET-300-1	TD-323 TD-312	TP-080 (Qty. 2)
	U/T1, V/T2, W/T3	3/0		80-L12			TP-080

## A.4 Drive Derating Data

Table A.27 Panduit Closed-Loop Crimp Terminal Size Single-Phase With Additional Impedance

Drive Model	Terminal	Recomm. Gauge With Additional Impedance AWG, kcmil	Screw Size	Panduit Ring Terminal (non-insulated)	Panduit Recomm.Installation Tool	Panduit Crimphead / Die Part No.	Insulation Cap Model No.
4□0002 4□0004 4□0005 4□0007 4□0009 4□0011	R/L1, S/L2 U/T1, V/T2, W/T3	14 14	M4	P14-8R	CT-1570	-	TP-003
4□0018	R/L1, S/L2 U/T1, V/T2, W/T3	12 12	M4	P10-8R	CT-1570	-	TP-005
4□0023	R/L1, S/L2 U/T1, V/T2, W/T3	12 12	M4	P10-8R	CT-1570	-	TP-005
4□0031	R/L1, S/L2 U/T1, V/T2, W/T3	10 10	M5	P10-10R	CT-1701	-	TP-005
4□0038	R/L1, S/L2 U/T1, V/T2, W/T3	8 10	M5	P8-10R P10-10R	CT-1701	-	TP-008 TP-005
4□0044	R/L1, S/L2 U/T1, V/T2, W/T3	6 6	M6	P6-14R	CT-1701	-	TP-014
4□0058	R/L1, S/L2 U/T1, V/T2, W/T3	8 10	M8	P8-56R P10-56R	CT-1701	-	TP-008 TP-005
4□0072	R/L1, S/L2 U/T1, V/T2, W/T3	4 10	M8	P4-56R P10-56R	CT-1701	-	TP-022 TP-005
4□0088	R/L1, S/L2 U/T1, V/T2, W/T3	4 6	M8	P4-56R P6-56R	CT-1701	-	TP-022 TP-014
4□0103	R/L1, S/L2 U/T1, V/T2, W/T3	6 6	M8	P6-56R	CT-1701	-	TP-014
4□0139	R/L1, S/L2 U/T1, V/T2, W/T3	1 6	M10	S2-38R S6-38R	CT-720	CD-720-2 CD-720-1	TP-060 TP-014
4□0165	R/L1, S/L2 U/T1, V/T2, W/T3	1 6	M10	S2-38R S6-38R	CT-720	CD-720-2 CD-720-1	TP-060 TP-014
4□0208	R/L1, S/L2 U/T1, V/T2, W/T3	2/0 4	M10	S2/0-38R S4-38R	CT-720	CD-720-2 CD-720-1	TP-080 TP-022
4□0250	R/L1, S/L2 U/T1, V/T2, W/T3	3/0 3	M10	S3/0-38R S2-38R-X	CT-720	CD-720-2	TP-080 TP-038
4□0296	R/L1, S/L2 U/T1, V/T2, W/T3	1 X 2P 2	M12	S2-12R-X (Qty. 2) S2-12R-X	CT-720	CD-720-2	TP-038 (Qty. 2) TP-038
4□0362	R/L1, S/L2 U/T1, V/T2, W/T3	2/0 X 2P 1/0	M12	S2/0-12R-X (Qty. 2) S1/0-12R-X	CT-720	CD-720-2	TP-080 (Qty. 2) TP-038
4□0414	R/L1, S/L2 U/T1, V/T2, W/T3	3/0 X 2P 3/0	M12	S3/0-12R-5 (QTY. 2) S3/0-12R-5	CT-720	CD-720-2	TP-080 (Qty. 2) TP-080
4□0515	R/L1, S/L2 U/T1, V/T2, W/T3	3/0 X 2P 3/0	M12	S3/0-12R-5 (QTY. 2) S3/0-12R-5	CT-720	CD-720-2	TP-080 (Qty. 2) TP-080
4□0675	R/L1, S/L2 U/T1, V/T2, W/T3	1 X 4P 4/0	M12	S2-12R-X (QTY. 4) S4/0-12R-5	CT-720	CD-720-2 CD-720-3	TP-038 (Qty. 4) TP-100



Table A.28 JST Closed-Loop Crimp Terminal Size Single-Phase With Additional Impedance

Drive Model	Terminal	Recomm. Gauge With Additional Impedance AWG, kcmil	Screw Size	JST Ring Terminal (non-insulated)	JST Recomm. Installation Tool	JST Crimphead / Die Part No.	Insulation Cap Model No.
4□0002 4□0004 4□0005 4□0007 4□0009 4□0011	R/L1, S/L2	14	M4	R2-4	YA-4	AD-900	TP-003
	U/T1, V/T2, W/T3	14					
4□0018	R/L1, S/L2	12	M4	R5.5-4	YA-4	AD-900	TP-005
	U/T1, V/T2, W/T3	12					
4□0023	R/L1, S/L2	12	M4	R5.5-4	YA-4	AD-900	TP-005
	U/T1, V/T2, W/T3	12					
4□0031	R/L1, S/L2	10	M5	R5.5-5	YA-4	AD-900	TP-005
	U/T1, V/T2, W/T3	10					
4□0038	R/L1, S/L2	8	M5	R8-5	YA-4	AD-901	TP-008
	U/T1, V/T2, W/T3	10		R5.5-5		AD-900	TP-005
4□0044	R/L1, S/L2	6	M6	R14-6	YA-5	AD-952	TP-014
	U/T1, V/T2, W/T3	6					
4□0058	R/L1, S/L2	8	M8	R8-8	YA-4	AD-901	TP-008
	U/T1, V/T2, W/T3	10		R5.5-8		AD-900	TP-005
4□0072	R/L1, S/L2	4	M8	R22-8	YA-5	AD-953	TP-022
	U/T1, V/T2, W/T3	10		R5.5-8	YA-4	AD-900	TP-005
4□0088	R/L1, S/L2	4	M8	R22-8	YA-5	AD-953	TP-022
	U/T1, V/T2, W/T3	6		R14-8	YA-5	AD-952	TP-014
4□0103	R/L1, S/L2	6	M8	R14-8	YA-5	AD-952	TP-014
	U/T1, V/T2, W/T3	6					
4□0139	R/L1, S/L2	1	M10	R38-10	YA-5	AD-954	TP-060
	U/T1, V/T2, W/T3	6		R14-10		AD-952	TP-014
4□0165	R/L1, S/L2	1	M10	R38-10	YA-5	AD-954	TP-060
	U/T1, V/T2, W/T3	6		R14-10		AD-952	TP-014
4□0208	R/L1, S/L2	2/0	M10	70-10	YF-1 YET-300-1	TD-323, TD-312	TP-080
	U/T1, V/T2, W/T3	4		R22-10	YA-5	AD-953	TP-022
4□0250	R/L1, S/L2	3/0	M10	80-10	YF-1 YET-300-1	TD-323, TD-312	TP-080
	U/T1, V/T2, W/T3	3		R38-10		TD-321, TD-311	TP-060
4□0296	R/L1, S/L2	1 X 2P	M12	R38-12 (Qty. 2)	YA-5	AD-954	TP-038 (Qty. 2)
	U/T1, V/T2, W/T3	2		R38-12			TP-038
4□0362	R/L1, S/L2	2/0 X 2P	M12	70-12(Qty. 2)	YF-1 YET-300-1	TD-322 TD-311	TP-080 (Qty. 2)
	U/T1, V/T2, W/T3	1/0		R60-12		TD-321 TD-311	TP-060
4□0414	R/L1, S/L2	3/0 X 2P	M12	80-L12 (Qty. 2)	YF-1 YET-300-1	TD-323 TD-312	TP-080 (Qty. 2)
	U/T1, V/T2, W/T3	3/0		80-L12		TP-080	
4□0515	R/L1, S/L2	3/0 X 2P	M12	80-L12 (Qty. 2)	YF-1 YET-300-1	TD-323 TD-312	TP-080 (QTY. 2)
	U/T1, V/T2, W/T3	3/0		80-L12		TP-080	
4□0675	R/L1, S/L2	1 X 4P	M12	R38-12 (QTY. 4)	YA-5	AD-954	TP-038 (Qty. 4)
	U/T1, V/T2, W/T3	4/0		100-L12			YF-1 YET-300-1

Specifications

**A**

## A.4 Drive Derating Data

**Table A.29 Panduit Closed-Loop Crimp Terminal Size Single-Phase With Additional Impedance**

Drive Model	Terminal	Recomm. Gauge With Additional Impedance AWG, kcmil	Screw Size	Panduit Ring Terminal (non-insulated)	Panduit Recomm. Installation Tool	Panduit Crimphead / Die Part No.	Insulation Cap Model No.
5□0003 5□0004 5□0006 5□0009	R/L1, S/L2	14	M4	P14-8R	CT-1570	-	TP-003
	U/T1, V/T2, W/T3	14					
5□0011	R/L1, S/L2	12	M4	P10-8R	CT-1570	-	TP-005
	U/T1, V/T2, W/T3	12					
5□0017	R/L1, S/L2	10	M5	P10-10R	CT-1701	-	TP-005
	U/T1, V/T2, W/T3	10					
5□0022	R/L1, S/L2	10	M5	P10-10R	CT-1701	-	TP-005
	U/T1, V/T2, W/T3	10					
5□0027 5□0032	R/L1, S/L2	6	M6	P6-14R	CT-1701	-	TP-014
	U/T1, V/T2, W/T3	6					
5□0041 5□0052	R/L1, S/L2	8	M8	P8-56R	CT-1701	-	TP-008
	U/T1, V/T2, W/T3	10		P10-56R			TP-005
5□0062	R/L1, S/L2	6	M10	P6-38R	CT-1701	-	TP-014
	U/T1, V/T2, W/T3	10		P10-38R			TP-005
5□0077 5□0099	R/L1, S/L2	4	M10	S4-38R	CT-720	CD-720-1	TP-022
	U/T1, V/T2, W/T3	8		S8-38R			TP-008
5□0125	R/L1, S/L2	1	M10	S2-38R	CT-720	CD-720-2	TP-060
	U/T1, V/T2, W/T3	6		S6-38R		CD-720-1	TP-014
5□0145	R/L1, S/L2	1	M10	S2-38R	CT-720	CD-720-2	TP-060
	U/T1, V/T2, W/T3	6		S6-38R		CD-720-1	TP-014
5□0192	R/L1, S/L2	3/0	M12	S3/0-12R-5	CT-720	CD-720-2	TP-080
	U/T1, V/T2, W/T3	3		S2-12R-X			TP-038
5□0242	R/L1, S/L2	3/0	M12	S3/0-12R-5	CT-720	CD-720-2	TP-080
	U/T1, V/T2, W/T3	3		S2-12R-X			TP-038

**Table A.30 JST Closed-Loop Crimp Terminal Size Single-Phase With Additional Impedance**

Drive Model	Terminal	Recomm. Gauge With Additional Impedance AWG, kcmil	Screw Size	JST Ring Terminal (non-insulated)	JST Recomm. Installation Tool	JST Crimphead / Die Part No.	Insulation Cap Model No.
5□0003 5□0004 5□0006 5□0009	R/L1, S/L2	14	M4	R2-4	YA-4	AD-900	TP-003
	U/T1, V/T2, W/T3	14					
5□0011	R/L1, S/L2	12	M4	R5.5-4	YA-4	AD-900	TP-005
	U/T1, V/T2, W/T3	12					
5□0017	R/L1, S/L2	10	M5	R5.5-5	YA-4	AD-900	TP-005
	U/T1, V/T2, W/T3	10					
5□0022	R/L1, S/L2	10	M5	R5.5-5	YA-4	AD-900	TP-005
	U/T1, V/T2, W/T3	10					
5□0027 5□0032	R/L1, S/L2	6	M6	R14-6	YA-5	AD-952	TP-014
	U/T1, V/T2, W/T3	6					
5□0041 5□0052	R/L1, S/L2	8	M8	R8-8	YA-4	AD-901	TP-008
	U/T1, V/T2, W/T3	10		R5.5-8		AD-900	TP-005
5□0062	R/L1, S/L2	6	M10	R14-10	YA-5	AD-952	TP-014
	U/T1, V/T2, W/T3	10		R5.5-10		AD-900	TP-005

Drive Model	Terminal	Recomm. Gauge With Additional Impedance AWG, kcmil	Screw Size	JST Ring Terminal (non-insulated)	JST Recomm. Installation Tool	JST Crimphead / Die Part No.	Insulation Cap Model No.
5□0077 5□0099	R/L1, S/L2	4	M10	R22-10	YA-5	AD-953	TP-022
	U/T1, V/T2, W/T3	8		R8-10		AD-951	TP-008
5□0125	R/L1, S/L2	1	M10	R38-10	YA-5	AD-954	TP-038
	U/T1, V/T2, W/T3	6		R14-10		AD-952	TP-014
5□0145	R/L1, S/L2	1	M10	R38-10	YA-5	AD-954	TP-038
	U/T1, V/T2, W/T3	6		R14-10		AD-952	TP-014
5□0192	R/L1, S/L2	3/0	M12	80-L12	YF-1 YET-300-1	TD-323, TD-312	TP-080
	U/T1, V/T2, W/T3	3		R38-12	YA-5	AD-954	TP-038
5□0242	R/L1, S/L2	3/0	M12	80-L12	YF-1 YET-300-1	TD-323, TD-312	TP-080
	U/T1, V/T2, W/T3	3		R38-12	YA-5	AD-954	TP-038

## A.4 Drive Derating Data

### ◆ Temperature Derating

To ensure the maximum performance life, the drive output current must be derated as shown in *Figure A.1* when the drive is installed in areas with high ambient temperature or if drives are mounted side-by-side in a cabinet. In order to ensure reliable drive overload protection, set parameters L8-12 and L8-35 according to the installation conditions.

#### ■ Parameter Settings

No.	Name	Description	Range	Def.
L8-12	Ambient Temperature Setting	Adjust the drive overload (oL2) protection level when the drive is installed in an environment that exceeds its ambient temperature rating.	-10 to +50	+40 °C
L8-35	Installation Method Selection	0: IP00/Open-Chassis Enclosure 1: Side-by-Side Mounting 2: IP20/NEMA 1, UL Type 1 Enclosure 3: Finless Drive or External Heatsink Installation	0 to 3	<1>

<1> Default setting is determined by drive model.

Setting 0: (Models 2A0250 to 2A0415 and 4A0208 to 4A1200)

Setting 2: (Models 2A0004 to 2A0211, 4A0002 to 4A0165, and 5A0003 to 5A0242).

#### Setting 0: IP00/Open-Chassis Enclosure

Drive operation between -10 °C and +50 °C allows 100% continuous current without derating.

#### Setting 1: Side-by-Side Mounting

Drive operation between -10 °C and +30 °C allows 100% continuous current without derating. Operation between +30 °C and +50 °C requires output current derating.

#### Setting 2: IP20/NEMA 1, UL Type 1 Enclosure

Drive operation between -10 °C and +40 °C allows 100% continuous current without derating. Operation between +40 °C and +50 °C requires output current derating.

#### Setting 3: External Heatsink Installation, Finless Drive

Drive operation between -10 °C and +40 °C allows 100% continuous current without derating. Operation between +40 °C and +50 °C requires output current derating.

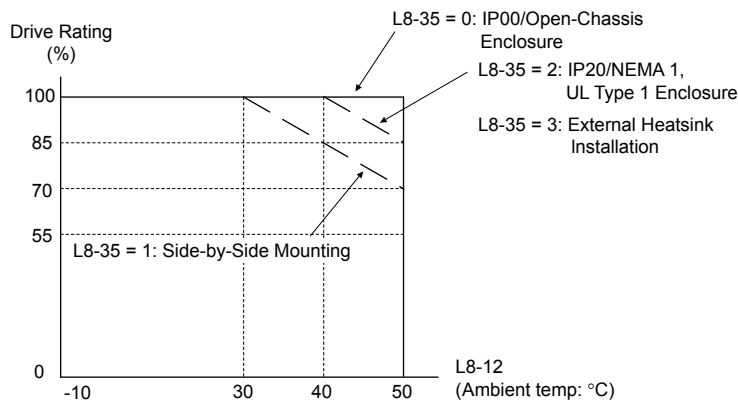

Figure A.1 Ambient Temperature and Installation Method Derating

### ◆ Altitude Derating

The drive standard ratings are valid for installation altitudes up to 1000 m. For installations from 1000 m to 3000 m, the drive rated voltage and the rated output current must be derated for 0.2% per 100 m.

# Appendix: B

## Parameter List

---

This appendix contains a full listing of all parameters and settings available in the drive.



<b>B.1</b>	<b>UNDERSTANDING PARAMETER DESCRIPTIONS.....</b>	<b>350</b>
<b>B.2</b>	<b>A: INITIALIZATION PARAMETERS.....</b>	<b>351</b>
<b>B.3</b>	<b>B: APPLICATION.....</b>	<b>353</b>
<b>B.4</b>	<b>C: TUNING.....</b>	<b>359</b>
<b>B.5</b>	<b>D: REFERENCES.....</b>	<b>362</b>
<b>B.6</b>	<b>E: MOTOR PARAMETERS.....</b>	<b>365</b>
<b>B.7</b>	<b>F: OPTIONS.....</b>	<b>368</b>
<b>B.8</b>	<b>H PARAMETERS: MULTI-FUNCTION TERMINALS.....</b>	<b>373</b>
<b>B.9</b>	<b>L: PROTECTION FUNCTION.....</b>	<b>388</b>
<b>B.10</b>	<b>N: SPECIAL ADJUSTMENT.....</b>	<b>396</b>
<b>B.11</b>	<b>O: OPERATOR-RELATED SETTINGS.....</b>	<b>398</b>
<b>B.12</b>	<b>P: PUMP PARAMETERS.....</b>	<b>402</b>
<b>B.13</b>	<b>Q: PID CONTROLLER PARAMETERS.....</b>	<b>422</b>
<b>B.14</b>	<b>S: SPECIAL APPLICATION.....</b>	<b>431</b>
<b>B.15</b>	<b>T: MOTOR TUNING.....</b>	<b>436</b>
<b>B.16</b>	<b>U: MONITORS.....</b>	<b>437</b>

## B.1 Understanding Parameter Descriptions

### ◆ Control Modes, Symbols, and Terms

The table below lists terms and symbols used in this section to indicate parameter availability and control.

Table B.1 Symbols and Icons Used in Parameter Descriptions

Symbol	Description
	Parameter is ONLY available when operating the drive with V/f control.
	Parameter is ONLY available when operating the drive with Open Loop Vector control.
	Parameter can be changed during run.

### ◆ Parameter Groups

Table B.2 iQpump Parameter Groups

Parameter Group	Name	Page	Parameter Group	Name	Page
A1	Initialization Parameters	<a href="#">351</a>	n1	Hunting Prevention	<a href="#">396</a>
A2	User Parameters	<a href="#">352</a>	n2	Speed Feedback Detection Control (AFR) Tuning	<a href="#">396</a>
b1	Operation Mode Selection	<a href="#">353</a>	n3	High Slip Braking (HSB) and Overexcitation Braking	<a href="#">396</a>
b2	DC Injection Braking and Short Circuit Braking	<a href="#">354</a>	n6	Online Tuning	<a href="#">397</a>
b3	Speed Search	<a href="#">354</a>	o1	Digital Operator Display Selection	<a href="#">398</a>
b4	Timer Function	<a href="#">355</a>	o2	Digital Operator Keypad Functions	<a href="#">399</a>
b5	PID Control	<a href="#">355</a>	o3	Copy Function	<a href="#">400</a>
b6	Dwell Function	<a href="#">357</a>	o4	Maintenance Monitor Settings	<a href="#">400</a>
b8	Energy Saving	<a href="#">358</a>	P1	Pump Basic	<a href="#">402</a>
C1	Acceleration and Deceleration Times	<a href="#">359</a>	P2	Pump Protection	<a href="#">405</a>
C2	S-Curve Characteristics	<a href="#">359</a>	P3	Contactormultiplexing	<a href="#">406</a>
C3	Slip Compensation	<a href="#">360</a>	P4	Pump Advanced	<a href="#">409</a>
C4	Torque Compensation	<a href="#">360</a>	P5	Pump HAND Mode	<a href="#">412</a>
C6	Carrier Frequency	<a href="#">361</a>	P6	Flow Meter Setup	<a href="#">413</a>
d1	Frequency Reference	<a href="#">362</a>	P7	Anti-Jam	<a href="#">416</a>
d2	Frequency Upper/Lower Limits	<a href="#">363</a>	P8	De-Scale / De-Ragging	<a href="#">417</a>
d3	Jump Frequency	<a href="#">363</a>	P9	Network Options	<a href="#">418</a>
d4	Frequency Reference Hold and Up/Down 2 Function	<a href="#">364</a>	Q1	Preset Setpoint	<a href="#">422</a>
E1	V/f Pattern	<a href="#">364</a>	Q2	Geothermal Mode Setup	<a href="#">422</a>
E2	Motor 1 Parameters	<a href="#">366</a>	Q3	Output Current Limit	<a href="#">423</a>
F4	Analog Monitor Card (AO-A3)	<a href="#">368</a>	Q4	Water Level Control	<a href="#">424</a>
F5	Digital Output Card (DO-A3)	<a href="#">368</a>	Q5	Suction Pressure Control	<a href="#">425</a>
F6, F7	Communication Option Card	<a href="#">369</a>	Q6	PI Auxiliary Control	<a href="#">427</a>
H1	Multi-Function Digital Inputs	<a href="#">373</a>	S1	Dynamic Noise Control Function	<a href="#">431</a>
H2	Multi-Function Digital Outputs	<a href="#">379</a>	S2	Programmable Run Timers	<a href="#">431</a>
H3	Multi-Function Analog Inputs	<a href="#">383</a>	S3	Secondary PI (PI2) Control	<a href="#">434</a>
H4	Multi-Function Analog Outputs	<a href="#">385</a>	S6	Protection	<a href="#">435</a>
H5	MEMOBUS/Modbus Serial Communication	<a href="#">386</a>	T1	Induction Motor Auto-Tuning	<a href="#">436</a>
H6	Pulse Train Input/Output	<a href="#">387</a>	U1	Operation Status Monitors	<a href="#">437</a>
L1	Motor Protection	<a href="#">388</a>	U2	Fault Trace	<a href="#">440</a>
L2	Momentary Power Loss Ride-Thru	<a href="#">389</a>	U3	Fault History	<a href="#">442</a>
L3	Stall Prevention	<a href="#">390</a>	U4	Maintenance Monitors	<a href="#">443</a>
L4	Speed Detection	<a href="#">391</a>	U5	PID Monitors	<a href="#">446</a>
L5	Fault Restart	<a href="#">392</a>	U6	Operation Status Monitors	<a href="#">447</a>
L6	Torque Detection	<a href="#">393</a>	U7	CASE Monitors	<a href="#">447</a>
L7	Torque Limit	<a href="#">394</a>	U9	Operation Status Monitors	<a href="#">447</a>
L8	Drive Protection	<a href="#">394</a>			

## B.2 A: Initialization Parameters

The A parameter group creates the operating environment for the drive. This includes the parameter Access Level, Motor Control Method, Password, User Parameters and more.

### ◆ A1: Initialization

No. (Addr. Hex)	Name	LCD Display	Description	Values	Page
A1-00 (0100) RUN <1>	Language Selection	Select Language 0: English 1: ニホンゴ (Japanese) 2: Deutsch 3: Français 4: Italiano 5: Español 6: Português	0: English 1: Japanese 2: German 3: French 4: Italian 5: Spanish 6: Portuguese	Default: 0 Range: 0 to 6	–
A1-01 (0101) RUN <2>	Access Level Selection	Access Level 0: Operation Only 1: User Parameters 2: Advanced Level 3: Lock parameters	0: View and set A1-01 and A1-04. U□-□□ parameters can also be viewed. 1: User Parameters (access to parameters selected by the user, A2-01 to A2-32) 2: Advanced Access (access to view and set all parameters) 3: Lock parameters	Default: 2 Range: 0 to 3	210
A1-02 (0102)	Control Method Selection	Control Method 0: V/f Control 2: Open Loop Vector	0: V/f Control 2: Open Loop Vector Control	Default: 0 Range: 0, 2	–
A1-03 (0103)	Initialize Parameters	Init Parameters 0: No Initialize 1110: User Initialize 2220: 2-Wire Initial 3330: 3-Wire Initial 5550: Term->Cntrl Int 6008: Pressure Control 6009: Pump down level 6010: Geothermal mode 6011: VTC Pressure Ctl 6012: Pivot Panel VTC 6013: Adv PressureCtrl 6014: Pivot Panel Sub 7770: General purpose 7771: Sub Mtr GP Oper	0: No initialization 1110: User Initialize (parameter values must be stored using parameter o2-03) 2220: 2-Wire initialization 3330: 3-Wire initialization 5550: Terminal->Control Initialize 6008: Pressure Control 6009: Pump down level 6010: Geothermal mode 6011: VTC pressure control 6012: Pivot Panel VTC <3> 6013: Advanced Pressure Control <3> 6014: Pivot Panel Submersible <4> 7770: General purpose 7771: Submersible Motor General Purpose <b>Note:</b> A1-03 is initially set to "6008" from the factory, although the keypad will always display "0".	Default: 0 Range: 0 to 5550; 6008 to 6014; 7770, 7771	210
A1-04 (0104)	Password	Enter Password	When the value set into A1-04 does not match the value set into A1-05, parameters A1-01 through A1-03 and A2-01 through A2-33 cannot be changed.	Default: 0000 Min.: 0000 Max.: 9999	–
A1-05 (0105)	Password Setting	Select Password			
A1-06 (0127)	Application Preset	Application Sel 0: Pressure Control 1: General Purpose 2: Sub Mtr GP Oper 5: General Ext HOA 6: General HOA Keys 8: Pressure Control 9: Pump Down Level 10: Geothermal Mode 11: VTC Pressure Ctl 12: Pivot Panel VTC 13: Adv PressureCtrl 14: Pivot Panel Sub	<b>Note:</b> This parameter is not settable. It is used as a monitor only. 0: Pressure Control 1: General Purpose 2: Sub Mtr GP Oper 5: General Ext HOA <3> 6: General HOA Keys <3> 8: Pressure Control 9: Pump Down Level 10: Geothermal Mode 11: VTC Pressure Ctl 12: Pivot Panel VTC 13: Adv PressureCtrl 14: Pivot Panel Sub <4>	Default: 0 Range: 0 to 2; 5, 6; 8 to 14	–
A1-08 <3> (0F00)	Custom Initialize Modes	Custom InitModes 0: No Initialize 3005: General Ext HOA 3006: General HOA Keys	0: No Initialization 3005: General Ext HOA 3006: General HOA Keys	Default: 0 Range: 0, 3005, 3006	212

<1> Parameter setting value is not reset to the default value when the drive is initialized.

<2> Default setting value is dependent on the Initialization parameter A1-03.

<3> Available in drive software versions PRG: 8552 and later. Not available in drive models 4A0930 and 4A1200.

<4> Available in drive software versions PRG: 8553 and later. Not available in drive models 4A0930 and 4A1200.

### ◆ A2: User Parameters

No. (Addr. Hex)	Name	LCD Display	Description	Values	Page
A2-01 to A2-32 (0106 to 0125)	User Parameters 1 to 32	User Param 1 - 32	Recently edited parameters are listed here. The user can also select parameters to appear here for quicker access.	Default: <1> Range: b1-01 to S6-07	–
A2-33 (0126)	User Parameter Automatic Selection	User Parms Sel 0: Disabled 1: Enabled	0: A2-01 to A2-32 are reserved for the user to create a list of User Parameters. 1: Save history of recently viewed parameters. Recently edited parameters will be saved to A2-17 through A2-32 for quicker access.	Default: 0 Range: 0, 1	–

<1> Default setting value is dependent on the Initialization parameter A1-03.



## B.3 b: Application

Application parameters configure the source of the Run command, DC Injection Braking, Speed Search, timer functions, PID control, the Dwell function, Energy Savings, and other application-related settings.

### ◆ b1: Operation Mode Selection

No. (Addr. Hex)	Name	LCD Display	Description	Values	Page
b1-01 (0180)	Frequency Reference Selection 1	Ref Source 1 0: Operator 1: Analog Input 2: Serial Com 3: Option PCB 4: Pulse Input 5: Geothermal	0: HOA keypad 1: Analog input terminals 2: MEMOBUS/Modbus communications 3: Option PCB 4: Pulse input (terminal RP) 5: Geothermal Mode (Frequency reference dependent on temperature input (H3-0□ = 21)	Default: 0 Range: 0 to 5	214
b1-02 (0181)	Run Command Selection 1	Run Source 1 0: Operator 1: Digital Inputs 2: Communication 3: Option PCB 6: AUTOKey + Term 7: AUTOKey + Serial 8: AUTOKey + Option	0: HOA keypad 1: Digital input terminals 2: MEMOBUS/Modbus communications 3: Option PCB 6: AUTOKey + Term </> 7: AUTOKey + Serial </> 8: AUTOKey + Option </>	Default: 0 Range: 0 to 3; 6 to 8	217
b1-03 (0182)	Stopping Method Selection	Stopping Method 0: Ramp to Stop 1: Coast to Stop 2: DCInj to Stop 3: Coast w/Timer	0: Ramp to stop 1: Coast to stop 2: DC Injection Braking to stop 3: Coast with timer	Default: 1 Range: 0 to 3	218
b1-04 (0183)	Reverse Operation Selection	Reverse Oper 0: Reverse Enabled 1: Reverse Disabled	0: Reverse enabled 1: Reverse disabled	Default: 1 Range: 0, 1	–
b1-07 (0186)	Run Command Retention when Source is Changed	RunCmd@SrcChange 0: Require Cycle 1: Retain Run Cmd	Determines whether the run command is retained when the Sequence Selection is changed 0: Require Cycle 1: Retain Run Command	Default: 0 Range: 0, 1	–
b1-08 (0187)	Run Command Selection in Programming Mode	RUN dur PRG Mode 0: Run Disabled@PRG 1: Run Enabled@PRG 2: Prg only @ Stop	0: Run command is not accepted while in Programming Mode. 1: Run command is accepted while in Programming Mode. 2: Prohibit entering Programming Mode during run.	Default: 0 Range: 0 to 2	–
b1-11 (01DF)	Run Delay at Stop (Back Spin Timer)	Run Delay @ Stop	Sets the amount of time that the drive will disallow the reapplication of the Run command after the Run command is lost. b1-11 is active for all b1-03 settings. If set to zero and b1-03 = 3 (Coast to Stop w/ Timer), a combination of C1-02 and output frequency determine the length of time. Otherwise, no run delay will be applied.	Default: 0.0 s Min.: 0.0 Max.: 6000.0	–
b1-12 (01E0) </>	Run Delay Memory Selection	Run Dly Mem Sel	Determines whether the Run Delay Timer is saved to the EEPROM during power loss. 0: Disabled 1: Only at Stop 2: Running & Stop <b>Note:</b> A JVOP-183 HOA Keypad must be plugged into the drive for settings 1 and 2 to function. If the keypad is removed, b1-12 will function as setting 0 (Disabled).	Default: 2 Range: 0 to 2	–
b1-14 (01C3)	Phase Order Selection	Rotation Sel 0: Standard 1: SwitchPhaseOrder	0: Standard 1: Switch phase order (reverses the direction of the motor)	Default: 0 Range: 0, 1	–
b1-15 (01C4) </>	Frequency Reference Selection 2	Ref Source 2 0: Operator 1: Analog Input 2: Serial Com 3: Option PCB 4: Pulse Input	Enabled when a multi-function digital input set for “External Reference” (H1-□□ = 2) closes. 0: Operator 1: Analog Input 2: Serial Communications 3: Option PCB 4: Pulse Input	Default: 0 Range: 0 to 4	–

## B.3 b: Application

No. (Addr. Hex)	Name	LCD Display	Description	Values	Page
b1-16 (01C5) <1>	Run Command Selection 2 Run Source 2	Run Source 2 0: Operator 1: Digital Inputs 2: Communication 3: Option PCB 6: AUTOKey + Term 7: AUTOKey + Serial 8: AUTOKey + Option	Enabled when a multi-function digital input set for “External Reference” (H1-□□ = 2) closes. 0: Operator 1: Digital Inputs 2: Communication 3: Option PCB 6: AUTOKey + Term <2> 7: AUTOKey + Serial <2> 8: AUTOKey + Option <2>	Default: 0 Range: 0 to 3; 6 to 8	–
b1-17 (01C6)	Run Command at Power Up	Run Cmd @ Pwr On 0: Cycle Ext Run 1: Accept Ext Run	0: Disregarded. A new Run command must be issued after power up. 1: Allowed. Motor will start immediately after power up if a Run command is already enabled.	Default: 1 Range: 0, 1	–

<1> Available in drive software versions PRG: 8551 and later.

<2> Available in drive software versions PRG: 8552 and later. Not available in drive models 4A0930 and 4A1200.

## ◆ b2: DC Injection Braking and Short Circuit Braking

No. (Addr. Hex)	Name	LCD Display	Description	Values	Page
b2-01 (0189)	DC Injection Braking Start Frequency	DCInj Start Freq	Sets the frequency at which DC Injection Braking starts when “Ramp to stop” (b1-03 = 0) is selected.	Default: 0.5 Hz Min.: 0.0 Max.: 10.0	–
b2-02 (018A)	DC Injection Braking Current	DCInj Current	Sets the DC Injection Braking current as a percentage of the drive rated current.	Default: 50% Min.: 0 Max.: 100	–
b2-03 (018B)	DC Injection Braking Time at Start	DCInj Time@Start	Sets DC Injection Braking time at start. Disabled when set to 0.00 seconds.	Default: 0.00 s Min.: 0.00 Max.: 10.00	–
b2-04 (018C)	DC Injection Braking Time at Stop	DCInj Time@Stop	Sets DC Injection Braking time at stop.	Default: 0.50 s Min.: 0.00 Max.: 10.00	–
b2-08 (0190)	Magnetic Flux Compensation Value	Field Comp	<b>OLV</b> Sets the magnetic flux compensation as a percentage of the no-load current value (E2-03).	Default: 0% Min.: 0 Max.: 1000	–

## ◆ b3: Speed Search

No. (Addr. Hex.)	Name	LCD Display	Description	Values	Page
b3-01 (0191)	Speed Search Selection at Start	SpdSrCh at Start 0: Disabled 1: Enabled	0: Disabled 1: Enabled	Default: 0 Range: 0, 1	<a href="#">220</a>
b3-02 (0192)	Speed Search Deactivation Current	SpdSrCh DeactCur	Sets the current level at which the speed is assumed to be detected and Speed Search is ended. Set as a percentage of the drive rated current.	Default: 120% (V/f) 100% (OLV) Min.: 0 Max.: 200	–
b3-03 (0193)	Speed Search Deceleration Time	SpdSrCh Dec Time	Sets output frequency reduction time during Speed Search.	Default: 2.0 s Min.: 0.1 Max.: 10.0	–
b3-04 (0194)	V/f Gain during Speed Search	SpdSrCh V/f	Determines how much to lower the V/f ratio during Speed Search. Output voltage during Speed Search equals the V/f setting multiplied by b3-04.	Default: <1> Min.: 10% Max.: 100%	–
b3-05 (0195)	Speed Search Delay Time	Search Delay	When using an external contactor on the output side, b3-05 delays executing Speed Search after a momentary power loss to allow time for the contactor to close.	Default: 0.2 s Min.: 0.0 Max.: 100.0	–

No. (Addr Hex.)	Name	LCD Display	Description	Values	Page
b3-06 (0196)	Output Current 1 during Speed Search	Srch Im Lvl1	Sets the current injected to the motor at the beginning of Speed Estimation Speed Search. Set as a coefficient for the motor rated current.	Default: </> Min.: 0.0 Max.: 2.0	–
b3-10 (019A)	Speed Search Detection Compensation Gain	Srch Detect Comp	Sets the gain which is applied to the speed detected by Speed Estimation Speed Search before the motor is reaccelerated. Increase this setting if ov occurs when performing Speed Search after a relatively long period of baseblock.	Default: 1.05 Min.: 1.00 Max.: 1.20	–
b3-14 (019E)	Bi-Directional Speed Search Selection	Bidir Search Sel 0: Disabled 1: Enabled	0: Disabled (uses the direction of the frequency reference) 1: Enabled (drive detects which way the motor is rotating)	Default: 1 Range: 0, 1	–
b3-17 (01F0)	Speed Search Restart Current Level	SrchRestart Lvl	Sets the Speed Search restart current level as a percentage of the drive rated current.	Default: 150% Min.: 0 Max.: 200	–
b3-18 (01F1)	Speed Search Restart Detection Time	SrchRestart Time	Sets the time to detect Speed Search restart.	Default: 0.10 s Min.: 0.00 Max.: 1.00	–
b3-19 (01F2)	Number of Speed Search Restarts	Num of SrchRestr	Sets the number of times the drive can attempt to restart when performing Speed Search.	Default: 3 Min.: 0 Max.: 10	–
b3-24 (01C0)	Speed Search Method Selection	SpdSrch Method 0: CurrentDetection 1: Speed Estimation	0: Current Detection 1: Speed Estimation	Default: 0 Range: 0, 1	–
b3-25 (01C8)	Speed Search Wait Time	SpdSrch WaitTime	Sets the time the drive must wait between each Speed Search restart attempt.	Default: 0.5 s Min.: 0.0 Max.: 30.0	–
b3-26 (01C7)	Direction Determining Level	Spd Search Meth	Sets the level that determines the direction of motor rotation. <b>Note:</b> This parameter is only available in models 4A0930 and 4A1200.	Default: </> Min.: 40 Max.: 60000	–
b3-27 (01C9)	Start Speed Search Select	Spd Search By AI 0: start from 0 1: start SPD	Selects a condition to activate Speed Search Selection at Start (b3-01) or External Speed Search Command 1 or 2 from the multi-function input. 0: Triggered when a Run command is issued (normal). 1: Triggered when an external baseblock is released.	Default: 0 Range: 0, 1	–

<1> Default setting is dependent on parameter o2-04, Drive Model Selection.

### ◆ b4: Timer Function

No. (Addr Hex.)	Name	LCD Display	Description	Values	Page
b4-01 (01A3)	Timer Function On-Delay Time	Delay-ON Timer	Sets the on-delay and off-delay times for a digital timer output (H2-□□=12). The output is triggered by a digital input programmed to H1-□□=18).	Default: 0.0 s Min.: 0.0 Max.: 3000.0	–
b4-02 (01A4)	Timer Function Off-Delay Time	Delay-OFF Timer		Default: 0.0 s Min.: 0.0 Max.: 3000.0	–

### ◆ b5: PID Control

No. (Addr Hex.)	Name	LCD Display	Description	Values	Page
b5-01 (01A5)	PID Function Setting	PID Mode 0: Disabled 1: Enabled D=Fdbk	0: Disabled 1: Enabled (PID output becomes output frequency reference, deviation D controlled)	Default: 1 Range: 0, 1	220
b5-02 (01A6) [RUN]	Proportional Gain Setting (P)	PID Gain	Sets the proportional gain of the PID controller. The function of b5-02 is disabled when P1-24 > 0	Default: 2.00 Min.: 0.00 Max.: 25.00	–
b5-03 (01A7) [RUN]	Integral Time Setting (I)	PID I Time	Sets the integral time for the PID controller.	Default: 3.0 s Min.: 0.0 Max.: 360.0	220

## B.3 b: Application

No. (Addr. Hex)	Name	LCD Display	Description	Values	Page
b5-04 (01A8) <span style="border: 1px solid black; padding: 1px;">RUN</span>	Integral Limit Setting	PID I Limit	Sets the maximum output possible from the integrator as a percentage of the maximum output frequency. The function of b5-04 is disabled when P1-24 > 0	Default: 100.0% Min.: 0.0 Max.: 100.0	–
b5-05 (01A9) <span style="border: 1px solid black; padding: 1px;">RUN</span>	Derivative Time (D)	PID D Time	Sets D control derivative time.	Default: 0.00 s Min.: 0.00 Max.: 10.00	–
b5-06 (01AA) <span style="border: 1px solid black; padding: 1px;">RUN</span>	PID Output Limit	PID Limit	Sets the maximum output possible from the entire PID controller as a percentage of the maximum output frequency.	Default: 100.0% Min.: 0.0 Max.: 100.0	–
b5-07 (01AB) <span style="border: 1px solid black; padding: 1px;">RUN</span>	PID Offset Adjustment	PID Offset	Applies an offset to the PID controller output. Set as a percentage of the maximum output frequency.	Default: 0.0% Min.: -100.0 Max.: 100.0	–
b5-08 (01AC) <span style="border: 1px solid black; padding: 1px;">RUN</span>	PID Primary Delay Time Constant	PID Delay Time	Sets a low pass filter time constant on the output of the PID controller.	Default: 0.00 s Min.: 0.00 Max.: 10.00	–
b5-09 (01AD)	PID Output Level Selection	Output Level Sel 0: Direct Acting 1: Inverse Acting	0: Direct acting 1: Inverse acting	Default: 0 Range: 0, 1	220
b5-10 (01AE) <span style="border: 1px solid black; padding: 1px;">RUN</span>	PID Output Gain Setting	Output Gain	Sets the gain applied to the PID output.  <b>Note:</b> Parameter setting cannot be changed when the drive is operating the motor in models 4A0930 and 4A1200.	Default: 1.00 Min.: 0.00 Max.: 25.00	–
b5-11 (01AF)	PID Output Reverse Selection	Output Rev Sel 0: 0 limit 1: Reverse	0: Negative PID output triggers zero limit. 1: Rotation direction reverses with negative PID output.  <b>Note:</b> When using setting 1, make sure reverse operation is permitted by b1-04.	Default: 0 Range: 0, 1	–
b5-12 (01B0)	Feedback Loss 4 to 20 mA Detection Selection	Fdbk 4-20mA Det 0: Disabled 1: Alarm Only 2: Fault 3: Run At b5-13	Performs a 4 to 20 mA wire break detection on the analog input that is programmed for PID feedback. 0: Disabled 1: Alarm only 2: Fault 3: Run at b5-13	Default: 2 Range: 0 to 3	–
b5-13 (01B1) <span style="border: 1px solid black; padding: 1px;">RUN</span>	Feedback Loss Goto Frequency	FdbkLossGotoFreq	Sets the speed at which the drive will run if a 4 to 20 mA wire break is detected on the PID Feedback and when b5-12 is set to 3 (Run at b5-13).	Default: 0.0 Hz Min.: 0.0 Max.: 400.0	–
b5-14 (01B2) <span style="border: 1px solid black; padding: 1px;">RUN</span>	Feedback Loss of Prime Level	FdbkLoss LOP Lvl	Detects loss of prime in the pump when a wire break condition has occurred. When the measured quantity determined by P1-18 (output current, kilowatts, or power) drops below this level for the time set in P1-20 and the output frequency is at the level set in b5-13, a “Loss of Prime” condition occurs. The drive responds to the “Loss of Prime” condition depending on the setting of P1-22, Loss of Prime Selection.	Default: 0.0 A </> Min.: 0.0 Max.: 1000.0	–
b5-15 (01B3) <span style="border: 1px solid black; padding: 1px;">RUN</span> </>	Feedback Loss Go To Frequency Time Out	FdbkLossGotoTimO	When b5-12 = 3 and the Feedback signal is lost, the drive will run at the b5-13 speed for the b5-15 time, after which the drive will fault on Feedback Loss (FDBKL). Timeout is disabled when set to 0sec and the drive will run indefinitely at b5-13.	Default: 0 s Min.: 0 Max.: 6000	–
b5-16 (01B3) <span style="border: 1px solid black; padding: 1px;">RUN</span> </>	Feedback Loss Start Delay	FdbkLossStartDly	When an AUTO Run command is initiated, the drive will not fault on Feedback Loss (FDBKL) or use the Feedback Loss GoTo Frequency (b5-13) until the b5-16 time has expired.	Default: 0.0 s Min.: 0.0 Max.: 120.0	–
b5-17 (01B5)	PID Accel/Decel Time	PID Acc/Dec Time	Sets the acceleration and deceleration time to PID setpoint.	Default: 0.0 s Min.: 0.0 Max.: 6000.0	–
b5-32 (01EE) <span style="border: 1px solid black; padding: 1px;">RUN</span> </>	Integrator Ramp Limit	IntegratrRampLim	When set to a value greater than zero, the PI Integrator is forced to be within +/- this amount of the soft starter output.	Default: 0.0 Hz Min.: 0.0 Max.: 10.0	–
b5-34 (019F) <span style="border: 1px solid black; padding: 1px;">RUN</span>	PID Output Lower Limit	PID Out Low Lim	Sets the minimum output possible from the PID controller as a percentage of the maximum output frequency.	Default: 0.00% Min.: -100.00 Max.: 100.00	–

No. (Addr. Hex)	Name	LCD Display	Description	Values	Page
b5-35 (01A0) <u>RUN</u>	PID Input Limit	PID Input Limit	Limits the PID control input (deviation signal) as a percentage of the maximum output frequency. Acts as a bipolar limit.	Default: 1000.0% Min.: 0.0 Max.: 1000.0	-
b5-39 (01FF)	PID Setpoint Display Digits	PID UsrDspDigits 0: No Dec (XXXXX) 1: 1 Dec (XXXX.X) 2: 2 Dec (XXX.XX) 3: 3 Dec (XX.XXX)	0: No decimal places 1: One decimal place 2: Two decimal places 3: Three decimal places	Default: 1 Range: 0 to 3	221
b5-40 (017F)	Frequency Reference Monitor Content during PID	Fref Mon Sel@PID 0: Fref Mon w PID 1: Fref Mon w/o PID	0: Display the frequency reference (U1-01) after PID compensation has been added. 1: Display the frequency reference (U1-01) before PID compensation has been added.	Default: 0 Range: 0, 1	-
b5-41 (0160)	PI Output 2 Unit Selection	PI Out2 Unit Sel 0: No Unit 1: PSI :lb/SqrInch 2: Pa:Pascals 3: Bar:Bar 4: "WC: InchOfWater 5: "Hg:Inch Mercury 6: ft: feet 7: m: meters 8: °F:DegFahrenheit 9: °C:DegCelsius 10: %: Percent 25: Flow (use P6-04)	0: No Unit 1: Pounds per square inch 2: Pascals 3: Bar 4: Inch of Water 5: Inch of Mercury 6: Feet 7: Meters 8: Degrees Fahrenheit 9: Degrees Celsius 10: Percent 25: Flow (use P6-04)	Default: 0 Range: 0 to 10; 25	-
b5-42 (0161) <u>RUN</u>	PI Output 2 Calculation Mode	PI Out2 Cal Mode 0: Linear 1: Square Root 2: 1/f2 3: 1/f3	0: Linear - the monitor displays PID output 1: Square root - the monitor displays square root PID output 2: Quadratic - the monitor displays 1/(PID output) <sup>2</sup> 3: Cubic - the monitor displays 1/(PID output) <sup>3</sup> <b>Note:</b> Used for U5-14 and U5-15 only.	Default: 0 Range: 0 to 3	-
b5-43 (0162) <u>RUN</u>	PI Output 2 Monitor Max Upper 4 Digits	PI Out2 MonMax U	Sets the upper 4 digits of the maximum monitor value. Used with b5-44 to set maximum monitor value of U5-14 and U5-15 at maximum frequency. <b>Note:</b> Used for U5-14 and U5-15 only.	Default: 0 Min.: 0 Max.: 9999	-
b5-44 (0163) <u>RUN</u>	PI Output 2 Monitor Max Lower 4 Digits	PI Out2 MonMax L	Sets the lower 4 digits of the maximum monitor value. Used with b5-43 to set maximum monitor value of U5-14 and U5-15 at maximum frequency. <b>Note:</b> Used for U5-14 and U5-15 only.	Default: 0 Min.: 0 Max.: 99.99	-
b5-45 (0164) <u>RUN</u>	PI Output 2 Monitor Minimum	PI Out2 MonMin	Sets the minimum display value at zero speed. This function is effective when b5-42 is set to 0 (Linear output mode). <b>Note:</b> Used for U5-14 and U5-15 only.	Default: 0 Min.: 0 Max.: 999.9	-
b5-47 (017D)	Reverse Operation Selection 2 by PID Output	Output Rev Sel2 0: 0 limit 1: Reverse	0: Zero limit when PID output is a negative value. 1: Reverse operation when PID output is a negative value (Zero limit if the reverse operation is prohibited by b1-04).	Default: 1 Range: 0, 1	-

- <1> Unit text is set by P1-18, Prime Loss Detection Method.
- <2> Available in drive software versions PRG: 8551 and later.

### ◆ b6: Dwell Function

No. (Addr. Hex)	Name	Description	Values	Page
b6-01 (01B6)	Dwell Reference at Start	Dwell Ref @Start	Parameters b6-01 and b6-02 set the frequency to hold and the time to maintain that frequency at start. Default: 0.0 Hz Min.: 0.0 Max.: 400.0	-
b6-02 (01B7)	Dwell Time at Start	Dwell Time @Start		Default: 0.0 s Min.: 0.0 Max.: 10.0

## B.3 b: Application

No. (Addr. Hex)	Name		Description	Values	Page
b6-03 (01B8)	Dwell Reference at Stop	Dwell Ref @Stop	Parameters b6-03 and b6-04 set the frequency to hold and the time to maintain that frequency at stop.	Default: 0.0 Hz Min.: 0.0 Max.: 400.0	–
b6-04 (01B9)	Dwell Time at Stop	Dwell Time @Stop		Default: 0.0 s Min.: 0.0 Max.: 10.0	–

## ◆ b8: Energy Saving

No. (Addr. Hex)	Name	LCD Display	Description	Values	Page
b8-01 (01CC)	Energy Saving Control Selection	Energy Save Sel 0: Disabled 1: Enabled	0: Disabled 1: Enabled	Default: 0 Range: 0, 1	–
b8-02 (01CD) [RUN]	Energy Saving Gain	Energy Save Gain	<b>OLV</b> Sets the gain used for Energy Saving.	Default: 0.7 Min.: 0.0 Max.: 10.0	–
b8-03 (01CE) [RUN]	Energy Saving Control Filter Time Constant	Energy Save F.T	<b>OLV</b> Sets a time constant for Energy Saving.	Default: <1> Min.: 0.00 s Max.: 10.00 s	–
b8-04 (01CF)	Energy Saving Coefficient Value	Energy Save COEF	<b>V/f</b> Determines the level of maximum motor efficiency. The display resolution depends on the rated output power of the drive.	Default: <1> <2> Min.: 0.00 Max.: 655.00 <3>	–
b8-05 (01D0)	Power Detection Filter Time	kW Filter Time	<b>V/f</b> Sets a time constant filter for output power detection.	Default: 20 ms Min.: 0 Max.: 2000	–
b8-06 (01D1)	Search Operation Voltage Limit	Search V Limit	<b>V/f</b> Sets the limit for the voltage search operation as a percentage of the motor rated voltage.	Default: 0% Min.: 0 Max.: 100	–

- <1> Default setting is dependent on parameter o2-04, Drive Model Selection.
- <2> Parameter value changes automatically if E2-11 is manually changed or changed by Auto-Tuning.
- <3> Setting range is 0.0 to 2000.0 for drives 3.7 kW and smaller.

## B.4 C: Tuning

C parameters are used to adjust the acceleration and deceleration times, S-curves, torque compensation, and carrier frequency selections.

### ◆ C1: Acceleration and Deceleration Times

No. (Addr. Hex)	Name	LCD Display	Description	Values	Page
C1-01 (0200) RUN	Acceleration Time 1	Accel Time 1	Sets the time to accelerate from 0 to maximum frequency.	Default: 20.0 s Min.: 0.0 Max.: 6000.0 <>	221
C1-02 (0201) RUN	Deceleration Time 1	Decel Time 1	Sets the time to decelerate from maximum frequency to 0.	Default: 10.0 s Min.: 0.0 Max.: 6000.0 <>	221
C1-03 (0202) RUN	Acceleration Time 2	Accel Time 2	Sets the time to accelerate from 0 to maximum frequency.		221
C1-04 (0203) RUN	Deceleration Time 2	Decel Time 2	Sets the time to decelerate from maximum frequency to 0.		221
C1-05 (0204) RUN	Acceleration Time 3	Accel Time 3	Sets the time to accelerate from 0 to maximum frequency.		221
C1-06 (0205) RUN	Deceleration Time 3	Decel Time 3	Sets the time to decelerate from maximum frequency to 0.		221
C1-09 (0208) RUN	Fast Stop Time	Fast Stop Time	Sets the time for the Fast Stop function. <b>Note:</b> Parameter setting cannot be changed when the drive is operating the motor in models 4A0930 and 4A1200.		Default: 10.0 s Min.: 0.0 Max.: 6000.0 <>
C1-10 (0209)	Accel/Decel Time Setting Units	Acc/Dec Units 0: 0.01 Seconds 1: 0.1 Seconds	0: 0.01 s (0.00 to 600.00 s) 1: 0.1 s (0.0 to 6000.0 s)	Default: 1 Range: 0, 1	–
C1-11 (020A)	Accel/Decel Time Switching Frequency	Acc/Dec SW Freq	Sets the frequency to switch between accel/decel time settings	Default: 0.0 Hz Min.: 0.0 Max.: 400.0	–

<1> Setting range value is dependent on parameter C1-10, Accel/Decel Time Setting Units. When C1-10 = 0 (units of 0.01 seconds), the setting range becomes 0.00 to 600.00 seconds.

### ◆ C2: S-Curve Characteristics

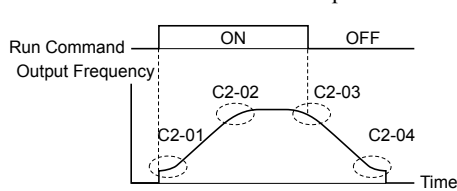
No. (Addr. Hex)	Name	LCD Display	Description	Values	Page
C2-01 (020B)	S-Curve Characteristic at Accel Start	SCrv Acc @ Start	The S-curve can be controlled at the four points shown below. 	Default: 0.20 s Min.: 0.00 Max.: 10.00	–
C2-02 (020C)	S-Curve Characteristic at Accel End	SCrv Acc @ End		Default: 0.20 s Min.: 0.00 Max.: 10.00	–
C2-03 (020D)	S-Curve Characteristic at Decel Start	SCrv Dec @ Start		Default: 0.20 s Min.: 0.00 Max.: 10.00	–
C2-04 (020E)	S-Curve Characteristic at Decel End	SCrv Dec @ End		Default: 0.00 s Min.: 0.00 Max.: 10.00	–

**◆ C3: Slip Compensation**

No. (Addr. Hex)	Name	LCD Display	Description	Values	Page
C3-01 (020F) [RUN]	Slip Compensation Gain	Slip Comp Gain	Sets the gain for the motor slip compensation function used for motor 1.	Default: 0.0 (V/f) 1.0 (OLV) Min.: 0.0 Max.: 2.5	–
C3-02 (0210) [RUN]	Slip Compensation Primary Delay Time	Slip Comp Time	Adjusts the slip compensation function delay time used for motor 1.	Default: 2000 ms (V/f) 200 ms (OLV) Min.: 0 Max.: 10000	–
C3-03 (0211)	Slip Compensation Limit	Slip Comp Limit	Sets an upper limit for the slip compensation function as a percentage of motor rated slip for motor 1 (E2-02).	Default: 200% Min.: 0 Max.: 250	–
C3-04 (0212)	Slip Compensation Selection during Regeneration	Slip Comp Regen 0: Disabled 1: Above 6 Hz 2: Lowest possbl spd	0: Disabled. 1: Enabled above 6 Hz 2: Enabled whenever slip compensation is possible.	Default: 0 Range: 0 to 2	–
C3-05 (0213)	Output Voltage Limit Operation Selection	Output V Lim Sel 0: Disabled 1: Enabled	<b>OLV</b> 0: Disabled. 1: Enabled. Automatically decreases motor flux when output voltage saturation is reached.	Default: 0 Range: 0, 1	–
C3-16 (0261)	Output Voltage Limit Operation Start Level (Percentage Modulation)	Output V Lim Sta	Sets the output voltage limit operation start level (percentage modulation) when C3-05 is enabled. <b>Note:</b> This parameter is only available in models 4A0930 and 4A1200.	Default: 85.0% Min.: 70.0 Max.: 90.0	–
C3-17 (0262)	Maximum Output Voltage Limit Level (Percentage Modulation)	Output V Lim Max	Sets the output voltage limit operation determined by C3-18 (percentage modulation) when C3-05 is enabled. <b>Note:</b> This parameter is only available in models 4A0930 and 4A1200.	Default: 90.0% Min.: 85.0 Max.: 100.0	–
C3-18 (0263)	Output Voltage Limit Level	Output V Lim lev	Sets the maximum percentage of output voltage reduction when C3-05 is enabled. <b>Note:</b> This parameter is only available in models 4A0930 and 4A1200.	Default: 90.0% Min.: 30.0 Max.: 100.0	–

**◆ C4: Torque Compensation**

No. (Addr. Hex)	Name	LCD Display	Description	Values	Page
C4-01 (0215) [RUN]	Torque Compensation Gain	Torq Comp Gain	Sets the gain for the automatic torque (voltage) boost function and helps to produce better starting torque. Used for motor 1.	Default: 1.00 Min.: 0.00 Max.: 2.50	–
C4-02 (0216) [RUN]	Torque Compensation Primary Delay Time 1	Torq Comp Time	Sets the torque compensation filter time.	Default: 200 ms (V/f) 20 ms (OLV) Min.: 0 Max.: 60000	–
C4-03 (0217)	Torque Compensation at Forward Start	F TorqCmp@start	<b>OLV</b> Sets torque compensation at forward start as a percentage of motor torque.	Default: 0.0% Min.: 0.0 Max.: 200.0	–
C4-04 (0218)	Torque Compensation at Reverse Start	R TorqCmp@start	<b>OLV</b> Sets torque compensation at reverse start as a percentage of motor torque.	Default: 0.0% Min.: -200.0 Max.: 0.0	–
C4-05 (0219)	Torque Compensation Time Constant	TorqCmp Delay T	<b>OLV</b> Sets the time constant for torque compensation at forward start and reverse start (C4-03 and C4-04).	Default: 10 ms Min.: 0 Max.: 200	–



No. (Addr. Hex)	Name	LCD Display	Description	Values	Page
C4-06 (021A)	Torque Compensation Primary Delay Time 2	Start Torq Time	<b>OLV</b> Sets the torque compensation time 2.	Default: 150 ms Min.: 0 Max.: 10000	–

## ◆ C6: Carrier Frequency



No. (Addr. Hex)	Name	LCD Display	Description	Values	Page
C6-02 (0224)	Carrier Frequency Selection	CarrierFreq Sel 1: 2.0 kHz 2: 5.0 kHz 3: 8.0 kHz 4: 10.0 kHz 5: 12.5 kHz 6: 15.0 kHz 7: Swing PWM1 (1.5 to 2.5 kHz Random) 8: Swing PWM2 (1.0 to 3.0 kHz Random) 9: Swing PWM3 (1.5 to 2.5 kHz Sinusoidal) A: Swing PWM4 (1.5 to 2.5 kHz Sinusoidal) B to E: No setting possible F: User-defined (determined by C6-03 through C6-05)	1: 2.0 kHz 2: 5.0 kHz (4.0 kHz) 3: 8.0 kHz (6.0 kHz) 4: 10.0 kHz (8.0 kHz) 5: 12.5 kHz (10.0 kHz) 6: 15.0 kHz (12.0 kHz) 7: Swing PWM1 (1.5 to 2.5 kHz Random) 8: Swing PWM2 (1.0 to 3.0 kHz Random) 9: Swing PWM3 (1.5 to 2.5 kHz Sinusoidal) A: Swing PWM4 (1.5 to 2.5 kHz Sinusoidal) B to E: No setting possible F: User-defined (determined by C6-03 through C6-05)  <b>Note:</b> The available settings are 1, 2, and F for models 4A0930 and 4A1200.	Default: 7 Range: 1 to 9; A, F	–
C6-03 (0225)	Carrier Frequency Upper Limit	CarrierFreq Max	Determines the upper and lower limits for the carrier frequency.  	Default: 2.0 kHz Min.: 1.0 Max.: 15.0 <1>	–
C6-04 (0226)	Carrier Frequency Lower Limit	CarrierFreq Min		Default: 2.0 kHz Min.: 1.0 Max.: 15.0 <1>	–
C6-05 (0227)	Carrier Frequency Proportional Gain	CarrierFreq Gain		Default: 0 Min.: 0 Max.: 99	–

<1> Upper limit is 5.0 kHz in models 4A0515 to 4A1200.

## B.5 d: References

Reference parameters set the various frequency reference values during operation.

### ◆ d1: Frequency Reference

No. (Addr. Hex)	Name	LCD Display	Description	Values	Page
d1-01 (0280) 	Frequency Reference 1	Reference 1	Sets the frequency reference for the drive. Setting units are determined by parameter o1-03.	Default: 0.00 Hz Min.: 0.00 Max.: 400.00 </>	–
d1-02 (0281) 	Frequency Reference 2	Reference 2	Sets the frequency reference for the drive. Setting units are determined by parameter o1-03.	Default: 0.00 Hz Min.: 0.00 Max.: 400.00 </>	–
d1-03 (0282) 	Frequency Reference 3	Reference 3	Sets the frequency reference for the drive. Setting units are determined by parameter o1-03.	Default: 0.00 Hz Min.: 0.00 Max.: 400.00 </>	–
d1-04 (0283) 	Frequency Reference 4	Reference 4	Sets the frequency reference for the drive. Setting units are determined by parameter o1-03.	Default: 0.00 Hz Min.: 0.00 Max.: 400.00 </>	–
d1-05 (0284) 	Frequency Reference 5	Reference 5	Sets the frequency reference for the drive. Setting units are determined by parameter o1-03.	Default: 0.00 Hz Min.: 0.00 Max.: 400.00 </>	–
d1-06 (0285) 	Frequency Reference 6	Reference 6	Sets the frequency reference for the drive. Setting units are determined by parameter o1-03.	Default: 0.00 Hz Min.: 0.00 Max.: 400.00 </>	–
d1-07 (0286) 	Frequency Reference 7	Reference 7	Sets the frequency reference for the drive. Setting units are determined by parameter o1-03.	Default: 0.00 Hz Min.: 0.00 Max.: 400.00 </>	–
d1-08 (0287) 	Frequency Reference 8	Reference 8	Sets the frequency reference for the drive. Setting units are determined by parameter o1-03.	Default: 0.00 Hz Min.: 0.00 Max.: 400.00 </>	–
d1-09 (0288) 	Frequency Reference 9	Reference 9	Sets the frequency reference for the drive. Setting units are determined by parameter o1-03.	Default: 0.00 Hz Min.: 0.00 Max.: 400.00 </>	–
d1-10 (028B) 	Frequency Reference 10	Reference 10	Sets the frequency reference for the drive. Setting units are determined by parameter o1-03.	Default: 0.00 Hz Min.: 0.00 Max.: 400.00 </>	–
d1-11 (028C) 	Frequency Reference 11	Reference 11	Sets the frequency reference for the drive. Setting units are determined by parameter o1-03.	Default: 0.00 Hz Min.: 0.00 Max.: 400.00 </>	–
d1-12 (028D) 	Frequency Reference 12	Reference 12	Sets the frequency reference for the drive. Setting units are determined by parameter o1-03.	Default: 0.00 Hz Min.: 0.00 Max.: 400.00 </>	–
d1-13 (028E) 	Frequency Reference 13	Reference 13	Sets the frequency reference for the drive. Setting units are determined by parameter o1-03.	Default: 0.00 Hz Min.: 0.00 Max.: 400.00 </>	–

No. (Addr. Hex)	Name	LCD Display	Description	Values	Page
d1-14 (028F) RUN	Frequency Reference 14	Reference 14	Sets the frequency reference for the drive. Setting units are determined by parameter o1-03.	Default: 0.00 Hz Min.: 0.00 Max.: 400.00 </>	–
d1-15 (0290) RUN	Frequency Reference 15	Reference 15	Sets the frequency reference for the drive. Setting units are determined by parameter o1-03.	Default: 0.00 Hz Min.: 0.00 Max.: 400.00 </>	–
d1-16 (0291) RUN	Frequency Reference 16	Reference 16	Sets the frequency reference for the drive. Setting units are determined by parameter o1-03.	Default: 0.00 Hz Min.: 0.00 Max.: 400.00 </>	–
d1-17 (0292) RUN	Jog Frequency Reference	Jog Reference	Sets the Jog frequency reference. Setting units are determined by parameter o1-03.	Default: 6.00 Hz Min.: 0.00 Max.: 400.00 </>	–

<1> Range upper limit is determined by parameters d2-01, Frequency Reference Upper Limit, and E1-04, Maximum Output Frequency.

### ◆ d2: Frequency Upper/Lower Limits

No. (Addr. Hex.)	Name	LCD Display	Description	Setting	Page
d2-01 (0289)	Frequency Reference Upper Limit	Ref Upper Limit	Sets the frequency reference upper limit as a percentage of the maximum output frequency.	Default: 100.0% Min.: 0.0 Max.: 110.0	–
d2-02 (028A)	Frequency Reference Lower Limit	Ref Lower Limit	Sets the frequency reference lower limit as a percentage of the maximum output frequency.	Default: 0.0% Min.: 0.0 Max.: 110.0	–
d2-03 (0293)	Master Speed Reference Lower Limit	Ref1 Lower Limit	Sets the lower limit for frequency references from analog inputs as a percentage of the maximum output frequency.	Default: 0.0% Min.: 0.0 Max.: 110.0	–

### ◆ d3: Jump Frequency

No. (Addr. Hex)	Name	LCD Display	Description	Values	Page
d3-01 (0294)	Jump Frequency 1	Jump Freq 1	Eliminates problems with resonant vibration of the motor/machine by avoiding continuous operation in predefined frequency ranges. The drive accelerates and decelerates the motor through the prohibited frequency ranges. Parameters must be set so that $d3-01 \geq d3-02 \geq d3-03$ . Setting this parameter to 0.0 disables the function.	Default: 0.0 Hz Min.: 0.0 Max.: 400.0	–
d3-02 (0295)	Jump Frequency 2	Jump Freq 2		Default: 0.0 Hz Min.: 0.0 Max.: 400.0	–
d3-03 (0296)	Jump Frequency 3	Jump Freq 3		Default: 0.0 Hz Min.: 0.0 Max.: 400.0	–
d3-04 (0297)	Jump Frequency Width	Jump Bandwidth		Sets the dead-band width around each selected prohibited frequency reference point.	Default: 1.0 Hz Min.: 0.0 Max.: 20.0

◆ d4: Frequency Reference Hold and Up/Down 2 Function

No. (Addr. Hex)	Name	LCD Display	Description	Values	Page
d4-01 (0298)	Frequency Reference Hold Function Selection	Fref Hold Sel 0: Disabled 1: Enabled	0: Disabled. Drive starts from zero when the power is switched on. 1: Enabled. At power up, the drive starts the motor at the Hold frequency that was saved.	Default: 0 Range: 0, 1	–
d4-03 (02AA) [RUN]	Frequency Reference Bias Step (Up/Down 2)	Up/Dn 2 Step Lvl	Sets the bias added to the frequency reference when the Up 2 and Down 2 digital inputs are enabled (H1-□□ = 75, 76).	Default: 0.00 Hz Min.: 0.00 Max.: 99.99	–
d4-04 (02AB) [RUN]	Frequency Reference Bias Accel/Decel (Up/Down 2)	Up/Dn 2 Ramp Sel 0: Sel Acc/Dec Time 1: Acc/Dec Time 4	0: Use selected accel/decel time. 1: Use accel/decel time 4 (C1-07 and C1-08). <b>Note:</b> The functionality of setting 1 is only accessible via MEMOBUS/Modbus communication.	Default: 0 Range: 0, 1	–
d4-05 (02AC) [RUN]	Frequency Reference Bias Operation Mode Selection (Up/Down 2)	Up/Dn 2 Bias Sel 0: Hold Bias Value 1: Reset Bias Value	0: Bias value is held if no input Up 2 or Down 2 is active. 1: When the Up 2 reference and Down 2 reference are both on or both off, the applied bias becomes 0. The specified accel/decel times are used for acceleration or deceleration.	Default: 0 Range: 0, 1	–
d4-06 (02AD)	Frequency Reference Bias (Up/Down 2)	Up/Dn 2 Bias Lvl	The Up/Down 2 bias value is saved in d4-06 when the frequency reference is not input by the digital operator. Set as a percentage of the maximum output frequency.	Default: 0.0% Min.: -99.9 Max.: 100.0	–
d4-07 (02AE) [RUN]	Analog Frequency Reference Fluctuation Limit (Up/Down 2)	Up/Dn 2 FluctLim	Limits how much the frequency reference is allowed to change while an input terminal set for Up 2 or Down 2 is enabled. If the frequency reference changes for more than the set value, then the bias value is held and the drive accelerates or decelerates to the frequency reference. Set as a percentage of the maximum output frequency.	Default: 1.0% Min.: 0.1 Max.: 100.0	–
d4-08 (2AF) [RUN]	Frequency Reference Bias Upper Limit (Up/Down 2)	Up/Dn 2 UpperLim	Sets the upper limit for the bias and the value that can be saved in d4-06. Set as a percentage of the maximum output frequency.	Default: 100.0% Min.: 0.0 Max.: 100.0	–
d4-09 (02B0) [RUN]	Frequency Reference Bias Lower Limit (Up/Down 2)	Up/Dn 2 LowerLim	Sets the lower limit for the bias and the value that can be saved in d4-06. Set as a percentage of the maximum output frequency.	Default: 0.0% Min.: -99.9 Max.: 0.0	–
d4-10 (02B6)	Up/Down Frequency Reference Limit Selection	Up/Dn LowLim Sel 0: D2-02 or Analog 1: D2-02 Only	0: The lower limit is determined by d2-02 or an analog input. 1: The lower limit is determined by d2-02.	Default: 0 Range: 0, 1	–

## B.6 E: Motor Parameters

### ◆ E1: V/f Pattern

No. (Addr. Hex)	Name	LCD Display	Description	Values	Page
E1-01 (0300)	Input Voltage Setting	Input Voltage	<p>This parameter must be set to the power supply voltage.</p> <p><b>WARNING! Electrical Shock Hazard. Drive input voltage (not motor voltage) must be set in E1-01 for the protective features of the drive to function properly. Failure to do so may result in equipment damage and/or death or personal injury.</b></p>	Default: 230 V <I> Min.: 155 Max.: 255 <I>	–
E1-03 (0302)	V/f Pattern Selection	V/F Selection 0: 50 Hz 1: 60 Hz Saturation 2: 50 Hz Saturation 3: 72 Hz 4: 50 Hz VT1 5: 50 Hz VT2 6: 60 Hz VT1 7: 60 Hz VT2 8: 50 Hz HST1 9: 50 Hz HST2 A: 60 Hz HST1 B: 60 Hz HST2 C: 90 Hz D: 120 Hz E: 180 Hz F: Custom V/F	0: 50 Hz, Constant torque 1 1: 60 Hz, Constant torque 2 2: 60 Hz, Constant torque 3 (50 Hz base) 3: 72 Hz, Constant torque 4 (60 Hz base) 4: 50 Hz, Variable torque 1 5: 50 Hz, Variable torque 2 6: 60 Hz, Variable torque 3 7: 60 Hz, Variable torque 4 8: 50 Hz, High starting torque 1 9: 50 Hz, High starting torque 2 A: 60 Hz, High starting torque 3 B: 60 Hz, High starting torque 4 C: 90 Hz (60 Hz base) D: 120 Hz (60 Hz base) E: 180 Hz (60 Hz base) F: Custom V/f, E1-04 through E1-13 settings define the V/f pattern	Default: F <I> Range: 0 to 9; A to FF	–

## B.6 E: Motor Parameters

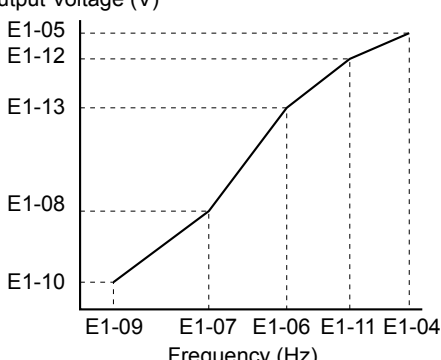
No. (Addr. Hex)	Name	LCD Display	Description	Values	Page
E1-04 (0303)	Maximum Output Frequency	Max Frequency	<p>These parameters are only applicable when E1-03 is set to F. To set linear V/f characteristics, set the same values for E1-07 and E1-09.</p> <p>In this case, the setting for E1-08 will be disregarded. Ensure that the four frequencies are set according to these rules:  <math>E1-09 \leq E1-07 &lt; E1-06 \leq E1-11 \leq E1-04</math></p> 	Default: 60.0 Hz Min.: 40.0 Max.: 400.0	–
E1-05 (0304)	Maximum Voltage	Max Voltage		Default: 230 V <1> Min.: 0.0 Max.: 255.0 <1>	–
E1-06 (0305)	Base Frequency	Base Frequency		Default: 60.0 Hz Min.: 0.0 Max.: E1-04	–
E1-07 (0306)	Middle Output Frequency	Mid Frequency A		Default: 3.0 Hz Min.: 0.0 Max.: E1-04	–
E1-08 (0307)	Middle Output Frequency Voltage	Mid Voltage A		Default: 15.0 V <1> Min.: 0.0 Max.: 255.0 <1>	–
E1-09 (0308)	Minimum Output Frequency	Min Frequency		Default: 1.5 Hz (V/f) 0.5 Hz (OLV) Min.: 0.0 Max.: E1-04	–
E1-10 (0309)	Minimum Output Frequency Voltage	Min Voltage		Default: 10.2 V (V/f) 2.0 V (OLV) <1> Min.: 0.0 Max.: 255.0 <1>	–
E1-11 (030A) <4>	Middle Output Frequency 2	Mid Frequency B		Default: 0.0 Hz Min.: 0.0 Max.: E1-04	–
E1-12 (030B) <4>	Middle Output Frequency Voltage 2	Mid Voltage B		Default: 0.0 V Min.: 0.0 Max.: 255.0 <1>	–
E1-13 (030C)	Base Voltage	Base Voltage		Default: 0.0 V <3> Min.: 0.0 Max.: 255.0 <1>	–

<1> Values shown are specific to 200 V class drives. Double the value for 400 V class drives. Multiply the value by 2.875 for 600 V class drives.

<2> Parameter setting value is not reset to the default value when the drive is initialized.

<3> When Auto-Tuning is performed, E1-13 and E1-05 will be set to the same value.

<4> Parameter ignored when E1-11 (Motor 1 Mid Output Frequency 2) and E1-12 (Motor 1 Mid Output Frequency Voltage 2) are set to 0.0.

## ◆ E2: Motor 1 Parameters

No. (Addr. Hex)	Name	LCD Display	Description	Values	Page
E2-01 (030E)	Motor Rated Current	Motor Rated FLA	Sets the motor nameplate full load current in amps. Automatically set during Auto-Tuning.	Default: <1> Min.: 10% of drive rated current Max.: 200% of drive rated current <2>	222
E2-02 (030F)	Motor Rated Slip	Motor Rated Slip	Sets the motor rated slip. Automatically set during Auto-Tuning.	Default: <1> Min.: 0.00 Hz Max.: 20.00 Hz	–
E2-03 (0310)	Motor No-Load Current	No-Load Current	Sets the no-load current for the motor. Automatically set during Auto-Tuning.	Default: <1> Min.: 0 A Max.: E2-01 <2>	–

No. (Addr. Hex)	Name	LCD Display	Description	Values	Page
E2-04 (0311)	Number of Motor Poles	Number of Poles	Sets the number of motor poles. Automatically set during Auto-Tuning.	Default: 2 Min.: 2 Max.: 48	–
E2-05 (0312)	Motor Line-to-Line Resistance	Term Resistance	Sets the phase-to-phase motor resistance. Automatically set during Auto-Tuning. <b>Note:</b> The units are expressed in mΩ in models 4A0930 and 4A1200.	Default: </> Min.: 0.000 Ω Max.: 65.000 Ω	–
E2-06 (0313)	Motor Leakage Inductance	Leak Inductance	Sets the voltage drop due to motor leakage inductance as a percentage of motor rated voltage. Automatically set during Auto-Tuning.	Default: </> Min.: 0.0% Max.: 40.0%	–
E2-07 (0314)	Motor Iron-Core Saturation Coefficient 1	Saturation Comp1	<b>OLV</b> Sets the motor iron saturation coefficient at 50% of magnetic flux. Automatically set during Auto-Tuning.	Default: 0.50 Min.: E2-07 Max.: 0.50	–
E2-08 (0315)	Motor Iron-Core Saturation Coefficient 2	Saturation Comp2	<b>OLV</b> Sets the motor iron saturation coefficient at 75% of magnetic flux. Automatically set during Auto-Tuning.	Default: 0.75 Min.: E2-07 Max.: 0.75	–
E2-09 (0316)	Motor Mechanical Loss	Mechanical Loss	<b>OLV</b> Sets the motor mechanical loss as a percentage of motor rated power (kW).	Default: 0.0% Min.: 0.0 Max.: 10.0	–
E2-10 (0317)	Motor Iron Loss for Torque Compensation	Motor Iron Loss	<b>V/f</b> Sets the motor iron loss.	Default: </> Min.: 0 W Max.: 65535 W	–
E2-11 (0318)	Motor Rated Power	Mtr Rated Power	Sets the motor rated power in kilowatts (1 HP = 0.746 kW). Automatically set during Auto-Tuning.	Default: </> Min.: 0.00 kW Max.: 650.00 kW	–
E2-20 (1103) RUN </>	Motor Service Factor Amps	Motor SF Amps	Sets the Motor Overload Current level for oL1 fault. When parameter is set to 0, Motor Rated Current (E2-01) is used instead for the oL1 fault calculation.	Default: 0.00 A </> Range: </>	–

- <1> Default setting is dependent on parameter o2-04, Drive Model Selection.
- <2> Display is in the following units:  
 2A0004 to 2A0040, 4A0002 to 4A0023, and 5A0007 to 5A0017: 0.01 A units.  
 2A0056 to 2A0415, 4A0031 to 4A0675, and 5A0022 to 5A0242: 0.1 A units.  
 4A0930 and 4A1200: 1 A units.
- <3> Available in drive software versions PRG: 8552 and later. Not available in drive models 4A0930 and 4A1200.
- <4> Range and resolution are dependent on drive size. Upper limit is 150% of drive ND current. When setting to a non-zero value, lower limit is 10% of drive ND current.
- <5> Default resolution is dependent on drive size.

## B.7 F: Options

### ◆ F4: Analog Monitor Card (AO-A3)

No. (Addr. Hex)	Name	LCD Display	Description	Values	Page
F4-01 (0391)	Terminal V1 Monitor Selection	AO Ch1 Select	Sets the monitor signal for output from terminal V1. Set this parameter to the last three digits of the desired U□-□□ monitor. Some U parameters are available only in certain control modes.	Default: 102 Range: 000 to 999	-
F4-02 (0392) <span style="border: 1px solid black; padding: 1px;">RUN</span>	Terminal V1 Monitor Gain	AO Ch1 Gain	Sets the gain for voltage output via terminal V1.	Default: 100.0% Min.: -999.9 Max.: 999.9	-
F4-03 (0393)	Terminal V2 Monitor Selection	AO Ch2 Select	Sets the monitor signal for output from terminal V2. Set this parameter to the last three digits of the desired U□-□□ monitor. Some U parameters are available only in certain control modes.	Default: 103 Range: 000 to 999	-
F4-04 (0394) <span style="border: 1px solid black; padding: 1px;">RUN</span>	Terminal V2 Monitor Gain	AO Ch2 Gain	Sets the gain for voltage output via terminal V2.	Default: 50.0% Min.: -999.9 Max.: 999.9	-
F4-05 (0395) <span style="border: 1px solid black; padding: 1px;">RUN</span>	Terminal V1 Monitor Bias	AO Ch1 Bias	Sets the amount of bias added to the voltage output via terminal V1.	Default: 0.0% Min.: -999.9 Max.: 999.9	-
F4-06 (0396) <span style="border: 1px solid black; padding: 1px;">RUN</span>	Terminal V2 Monitor Bias	AO Ch2 Bias	Sets the amount of bias added to the voltage output via terminal V2.	Default: 0.0% Min.: -999.9 Max.: 999.9	-
F4-07 (0397)	Terminal V1 Signal Level	AO Opt Level Ch1 0: 0-10 VDC 1: -10 +10 VDC	0: 0 to 10 V 1: -10 to 10 V	Default: 0 Range: 0, 1	-
F4-08 (0398)	Terminal V2 Signal Level	AO Opt Level Ch2 0: 0-10 VDC 1: -10 +10 VDC	0: 0 to 10 V 1: -10 to 10 V	Default: 0 Range: 0, 1	-

### ◆ F5: Digital Output Card (DO-A3)

No. (Addr. Hex)	Name	LCD Display	Description	Values	Page
F5-01 (399)	Terminal P1-PC Output Selection	DO Ch1 Select	Sets the function for contact output terminals M1-M2, M3-M4, and photocoupler output terminals P1 through P6. <i>Refer to H2: Multi-Function Digital Outputs on page 379 for setting selections.</i>	Default: 0 Range: 0 to 192	-
F5-02 (39A)	Terminal P2-PC Output Selection	DO Ch2 Select		Default: 1 Range: 0 to 192	-
F5-03 (39B)	Terminal P3-PC Output Selection	DO Ch3 Select		Default: 2 Range: 0 to 192	-
F5-04 (39C)	Terminal P4-PC Output Selection	DO Ch4 Select		Default: 4 Range: 0 to 192	-
F5-05 (39D)	Terminal P5-PC Output Selection	DO Ch5 Select		Default: 6 Range: 0 to 192	-
F5-06 (39E)	Terminal P6-PC Output Selection	DO Ch6 Select		Default: 37 Range: 0 to 192	-
F5-07 (39F)	Terminal M1-M2 Output Selection	DO Ch7 Select		Default: F Range: 0 to 192	-
F5-08 (3A0)	Terminal M3-M4 Output Selection	DO Ch8 Select		Default: F Range: 0 to 192	-
F5-09 (3A1)	DO-A3 Output Mode Selection	DO Function Sel 0: 8ch Individual 1: Binary Output 2: 8ch Selected	0: Output terminals are each assigned separate output functions. 1: Binary code output. 2: Use output terminal functions selected by parameters F5-01 through F5-08.	Default: 0 Range: 0 to 2	-



## ◆ F6, F7: Communication Option Card

Parameters F6-01 through F6-03 and F6-06 through F6-08 are used for DeviceNet and PROFIBUS-DP options. Other parameters in the F6 group are used for communication-protocol-specific settings.

No. (Addr. Hex)	Name	LCD Display	Description	Values	Page
F6-01 (03A2)	Communications Error Operation Selection	Comm Bus Flt Sel 0: Ramp to Stop 1: Coast to Stop 2: Fast-Stop 3: Alarm Only 4: Alarm(d1-04) 5: Alm – Ramp Stop	0: Ramp to stop. Decelerate to stop using the deceleration time in C1-02. 1: Coast to stop. 2: Fast Stop. Decelerate to stop using the deceleration time in C1-09. 3: Alarm only. 4: Alarm and Run at d1-04 5: Alarm and Ramp to stop (automatic recovery)	Default: 1 Range: 0 to 3	–
F6-02 (03A3)	External Fault from Comm. Option Detection Selection	EF0 Detection 0: Always Detected 1: Only During Run	0: Always detected. 1: Detection during run only.	Default: 0 Range: 0, 1	–
F6-03 (03A4)	External Fault from Comm. Option Operation Selection	EF0 Fault Action 0: Ramp to Stop 1: Coast to Stop 2: Fast-Stop 3: Alarm Only	0: Ramp to stop. Decelerate to stop using the deceleration time in C1-02. 1: Coast to stop. 2: Fast Stop. Decelerate to stop using the deceleration time in C1-09. 3: Alarm only.	Default: 1 Range: 0 to 3	–
F6-04 (03A5)	bUS Error Detection Time	BUS Err Det Time	Sets the delay time for error detection if a bus error occurs.	Default: 2.0 s Min.: 0.0 Max.: 5.0	–
F6-07 (03A8)	Multi-Step Speed Enable/Disable Selection when NefRef/ComRef is Selected	Fref PrioritySel 0: Net/Com REF 1: MultiStep Speed	0: Multi-step reference disabled 1: Multi-step reference enabled	Default: 0 Range: 0, 1	–
F6-08 (036A) </>	Reset Communication Parameters	Com Prm Init Sel 0: No Init Com Prms 1: Init Com Prms	0: Reset all communication-related parameters (F6-□□) when the drive is initialized using A1-03. 1: Communication-related parameters (F6-□□) are not reset when the drive is initialized using A1-03.	Default: 0 Range: 0, 1	–
F6-10 (03B6)	CC-Link Node Address	CC-Link Node Add	Sets the node address if a CC-Link option is installed.	Default: 0 Min.: 0 Max.: 64	–
F6-11 (03B7)	CC-Link Communication Speed	CC-Link Baud 0: 156 kbps 1: 625 kbps 2: 2.5 Mbps 3: 5 Mbps 4: 10 Mbps	0: 156 Kbps 1: 625 Kbps 2: 2.5 Mbps 3: 5 Mbps 4: 10 Mbps	Default: 0 Range: 0 to 4	–
F6-14 (03BB)	bUS Error Auto Reset	Bus Err Auto Rst 0: Disabled 1: Enabled	0: Disabled 1: Enabled	Default: 0 Range: 0, 1	–
F6-20 (036B)	Station Address	Station Address	Sets the station address when the MECHATROLINK option has been installed.	Default: 21 Min.: 03 </> Max.: EF </>	–
F6-21 (036C)	MECHATROLINK Frame Size	Frame length	0: 32-byte </> 1: 17-byte </>	Default: 0 Range: 0, 1	–
F6-22 (036D)	MECHATROLINK Link Speed	Link Speed 0: 10MHz 1: 4MHz	0: 10 Mbps 1: 4 Mbps	Default: 0 Range: 0, 1	–
F6-23 (036E)	MECHATROLINK Monitor Selection (E)	Mon E register	Sets the MECHATROLINK monitor (E).	Default: 0 Min.: 0 Max.: FFFF	–
F6-24 (036F)	MECHATROLINK Monitor Selection (F)	Mon F register	Sets the MECHATROLINK monitor (F).	Default: 0 Min.: 0 Max.: FFFF	–
F6-25 (03C9)	Operation Selection at MECHATROLINK Watchdog Timer Error (E5)	SI-T WDTErr Sel 0: Ramp to Stop 1: Coast to Stop 2: Fast-Stop 3: Alarm Only	0: Ramp to stop. Decelerate using the deceleration time in C1-02. 1: Coast to stop 2: Fast stop. Decelerate using the deceleration time in C1-09. 3: Alarm only	Default: 1 Range: 0 to 3	–

## B.7 F: Options

No. (Addr. Hex)	Name	LCD Display	Description	Values	Page
F6-26 (03CA)	MECHATROLINK bUS Errors Detected	Num of SI-T BUS	Sets the number of option communication errors (bUS).	Default: 2 Min.: 2 Max.: 10	–
F6-30 (03CB)	PROFIBUS-DP Node Address	PB Node Address	Sets the node address.	Default: 0 Min.: 0 Max.: 125	–
F6-31 (03CC)	PROFIBUS-DP Clear Mode Selection	PB Clear Select 0: Reset to Zero 1: Hold Prev Value	0: Resets drive operation with a Clear mode command. 1: Maintains the previous operation state when Clear mode command is given.	Default: 0 Range: 0, 1	–
F6-32 (03CD)	PROFIBUS-DP Data Format Selection	PB Map Select 0: PPO Type 1: Conventional	0: PPO Type 1: Conventional	Default: 0 Range: 0, 1	–
F6-45 (02FB)	BACnet Node Address	BAC Node Address	Sets the node address.	Default: 1 Min.: 0 Max.: 127	–
F6-46 (02FC)	BACnet Baud Rate	BAC Baud Rate 0: 1200 bps 1: 2400 bps 2: 4800 bps 3: 9600 bps 4: 19.2 kbps 5: 38.4 kbps 6: 57.6 kbps 7: 76.8 kbps 8: 115.2 kbps	0: 1200 bps 1: 2400 bps 2: 4800 bps 3: 9600 bps 4: 19.2 kbps 5: 38.4 kbps 6: 57.6 kbps 7: 76.8 kbps 8: 115.2 kbps	Default: 3 Range: 0 to 8	–
F6-47 (02FD)	Rx to Tx Wait Time	Rx to Tx Wait T	Rx to Tx Wait Time	Default: 5 ms Min.: 5 Max.: 65	–
F6-48 (02FE)	BACnet Device Object ID 0	BAC Dev Obj Id 0	BACnet device object ID	Default: 0 Min.: 0 Max.: FFFF	–
F6-49 (02FF)	BACnet Device Object ID 1	BAC Dev Obj Id 1	BACnet device object ID	Default: 0 Min.: 0 Max.: 3F	–
F6-50 (03C1)	DeviceNet MAC Address	DN MAC Address	Selects the drive MAC address.	Default: 64 Min.: 0 Max.: 64	–
F6-51 (03C2)	DeviceNet Communication Speed	DN Baud Rate 0: 125 kbps 1: 250 kbps 2: 500 kbps 3: Set from Network 4: Auto Detect	0: 125 kbps 1: 250 kbps 2: 500 kbps 3: Adjustable from network 4: Detect automatically	Default: 4 Range: 0 to 4	–
F6-52 (03C3)	DeviceNet PCA Setting	PCA Selection	Sets the format of the data set from the DeviceNet master to the drive.	Default: 21 Min.: 0 Max.: 255	–
F6-53 (03C4)	DeviceNet PPA Setting	PPA Selection	Sets the format of the data set from the drive to the DeviceNet master.	Default: 71 Min.: 0 Max.: 255	–
F6-54 (03C5)	DeviceNet Idle Mode Fault Detection	DN Idle Flt Det 0: Stop 1: Ignore	0: Enabled 1: Disabled, no fault detection	Default: 0 Range: 0, 1	–
F6-55 (03C6)	DeviceNet Baud Rate Monitor	DN BAUD RATE MEM 0: 125 kbps 1: 250 kbps 2: 500 kbps	Verifies the baud rate running on the network. 0: 125 kbps 1: 250 kbps 2: 500 kbps	Default: 0 Range: 0 to 2	–
F6-56 (03D7)	DeviceNet Speed Scaling	Speed Scale	Sets the scaling factor for the speed monitor in DeviceNet.	Default: 0 Min.: -15 Max.: 15	–
F6-57 (03D8)	DeviceNet Current Scaling	Current Scale	Sets the scaling factor for the output current monitor in DeviceNet.	Default: 0 Min.: -15 Max.: 15	–

No. (Addr. Hex)	Name	LCD Display	Description	Values	Page
F6-58 (03D9)	DeviceNet Torque Scaling	Torque Scale	Sets the scaling factor for the torque monitor in DeviceNet.	Default: 0 Min.: -15 Max.: 15	–
F6-59 (03DA)	DeviceNet Power Scaling	Power Scale	Sets the scaling factor for the power monitor in DeviceNet.	Default: 0 Min.: -15 Max.: 15	–
F6-60 (03DB)	DeviceNet Voltage Scaling	Voltage Scale	Sets the scaling factor for the voltage monitor in DeviceNet.	Default: 0 Min.: -15 Max.: 15	–
F6-61 (03DC)	DeviceNet Time Scaling	Time Scale	Sets the scaling factor for the time monitor in DeviceNet.	Default: 0 Min.: -15 Max.: 15	–
F6-62 (03DD)	DeviceNet Heartbeat Interval	DN Heart Beat	Sets the heartbeat interval for DeviceNet communications.	Default: 0 Min.: 0 Max.: 10	–
F6-63 (03DE)	DeviceNet Network MAC ID	DN MAC ID MEM	Saves and monitors settings 0 to 63 of F6-50 (DeviceNet MAC Address).	Default: 63 Min.: 0 Max.: 63	–
F6-64 to F6-71 (03DF to 03C8)	Reserved	–	Dynamic I/O Assembly Parameters	–	–
F6-72 (03DE)	PowerLink Node Address	PowerLink NodeID	Reserved.	–	–
F7-01 (03E5) <4>	IP Address 1	IP Address 1	Sets the most significant octet of network static IP address.	Default: 192 Range: 0 to 255	–
F7-02 (03E6) <4>	IP Address 2	IP Address 2	Sets the second most significant octet of network static IP address.	Default: 168 Range: 0 to 255	–
F7-03 (03E7) <4>	IP Address 3	IP Address 3	Sets the third most significant octet of network static IP address.	Default: 1 Range: 0 to 255	–
F7-04 (03E8) <4>	IP Address 4	IP Address 4	Sets the fourth most significant octet of network static IP address.	Default: 20 Range: 0 to 255	–
F7-05 (03E9)	Subnet Mask 1	Subnet Mask 1	Sets the most significant octet of network static Subnet Mask.	Default: 255 Range: 0 to 255	–
F7-06 (03EA)	Subnet Mask 2	Subnet Mask 2	Sets the second most significant octet of network static Subnet Mask.	Default: 255 Range: 0 to 255	–
F7-07 (03EB)	Subnet Mask 3	Subnet Mask 3	Sets the third most significant octet of network static Subnet Mask.	Default: 255 Range: 0 to 255	–
F7-08 (03EC)	Subnet Mask 4	Subnet Mask 4	Sets the fourth most significant octet of network static Subnet Mask.	Default: 0 Range: 0 to 255	–
F7-09 (03ED)	Gateway Address 1	Gateway IP Add 1	Sets the most significant octet of network Gateway address.	Default: 192 Range: 0 to 255	–
F7-10 (03EE)	Gateway Address 2	Gateway IP Add 2	Sets the second most significant octet of network Gateway address.	Default: 168 Range: 0 to 255	–
F7-11 (03EF)	Gateway Address 3	Gateway IP Add 3	Sets the third most significant octet of network Gateway address.	Default: 1 Range: 0 to 255	–
F7-12 (03E0)	Gateway Address 4	Gateway IP Add 4	Sets the fourth most significant octet of network Gateway address.	Default: 1 Range: 0 to 255	–
F7-13 (03F1)	Address Mode at Startup	IP Add Mode Sel 0: User Defined 1: BOOTP 2: DHCP	Select the option address setting method 0: Static <5> 1: BOOTP 2: DHCP	Default: 2 Range: 0 to 2	–
F7-14 (03F2)	Duplex Mode Selection	Duplex Select 0: Half Duplex 1: Auto Negotiate 2: Full Duplex	Selects duplex mode setting. 0: Half duplex forced 1: Auto-negotiate duplex mode and communication speed 2: Full duplex forced	Default: 1 Range: 0 to 2	–

## B.7 F: Options

No. (Addr. Hex)	Name	LCD Display	Description	Values	Page
F7-15 (03F3)	Communication Speed Selection	Baud Rate 10: 10 Mbps 100: 100 Mbps	Sets the communication speed 10: 10 Mbps 100: 100 Mbps	Default: 10 Range: 10, 100	–
F7-16 (03F4)	Communication Loss Timeout	CommLoss Tout	Sets the timeout value for communication loss detection in tenths of a second. A value of 0 disables the connection timeout. Example: An entered value of 100 represents 10.0 seconds.	Default: 0 Min.: 0 Max.: 300	–
F7-17 (03F5)	EtherNet/IP Speed Scaling Factor	EN Speed Scale	Sets the scaling factor for the speed monitor in EtherNet/IP Class ID 2AH Object.	Default: 0 Min.: -15 Max.: 15	–
F7-18 (03F6)	EtherNet/IP Current Scaling Factor	EN Current Scale	Sets the scaling factor for the output current monitor in EtherNet/IP Class ID 2AH Object.	Default: 0 Min.: -15 Max.: 15	–
F7-19 (03F7)	EtherNet/IP Torque Scaling Factor	EN Torque Scale	Sets the scaling factor for the torque monitor in EtherNet/IP Class ID 2AH Object.	Default: 0 Min.: -15 Max.: 15	–
F7-20 (03F8)	EtherNet/IP Power Scaling Factor	EN Power Scale	Sets the scaling factor for the power monitor in EtherNet/IP Class ID 2AH Object.	Default: 0 Min.: -15 Max.: 15	–
F7-21 (03F9)	EtherNet/IP Voltage Scaling Factor	EN Voltage Scale	Sets the scaling factor for the voltage monitor in EtherNet/IP Class ID 2AH Object.	Default: 0 Min.: -15 Max.: 15	–
F7-22 (03FA)	EtherNet/IP Time Scaling	EN Time Scale	Sets the scaling factor for the time monitor in EtherNet/IP Class ID 2AH Object.	Default: 0 Min.: -15 Max.: 15	–
F7-23 to F7-32 (03FB to 0374)	Dynamic Output Assembly Parameters	–	Parameters used in Output Assembly 116. Each parameter contains a MEMOBUS/Modbus address. The value received for Output Assembly 116 will be written to this corresponding MEMOBUS/Modbus address. A MEMOBUS/Modbus address value of 0 means that the value received for Output Assembly 116 will not be written to any MEMOBUS/Modbus register.	Default: 0	–
F7-33 to F7-42 (0375 to 037E)	Dynamic Input Assembly Parameters	–	Parameters used in Input Assembly 166. Each parameter contains a MEMOBUS/Modbus address. The value sent for Input Assembly 166 will be read from this corresponding MEMOBUS/Modbus address. A MEMOBUS/Modbus address value of 0 means that the value sent for Input Assembly 166 is not defined by the user, therefore the option default register value will be returned.	Default: 0	–

- <1> Parameter setting value is not reset to the default value when the drive is initialized.
- <2> Values shown are for the MECHATROLINK-II option (SI-T3). Values for MECHATROLINK-III option (SI-ET3) are:  
Min: 03  
Max.: EF
- <3> Values shown are for the MECHATROLINK-II option (SI-T3). Values for MECHATROLINK-III option (SI-ET3) are:  
0: 64-byte  
1: 32-byte
- <4> Cycle power for setting changes to take effect.
- <5> If F7-13 is set to 0, all IP addresses (F7-01 to F7-04) must be unique.

## B.8 H Parameters: Multi-Function Terminals

H parameters assign functions to the multi-function input and output terminals.

### ◆ H1: Multi-Function Digital Inputs

No. (Addr. Hex)	Name	LCD Display	Description	Values	Page
H1-01 (0438)	Multi-Function Digital Input Terminal S1 Function Selection	Term S1 Func Sel	Assigns a function to the multi-function digital inputs. Refer to pages 222 to 223 for descriptions of setting values. <b>Note:</b> Set unused terminals to F.	Default: 40 (F) </> Min.: 1 Max.: 9F	222
H1-02 (0439)	Multi-Function Digital Input Terminal S2 Function Selection	Term S2 Func Sel	Assigns a function to the multi-function digital inputs. Refer to pages 222 to 223 for descriptions of setting values. <b>Note:</b> Set unused terminals to F.	Default: F Min.: 1 Max.: 9F	222
H1-03 (0400)	Multi-Function Digital Input Terminal S3 Function Selection	Term S3 Func Sel	Assigns a function to the multi-function digital inputs. Refer to pages 222 to 223 for descriptions of setting values. <b>Note:</b> Set unused terminals to F.	Default: 26 Min.: 0 Max.: 9F	222
H1-04 (0401)	Multi-Function Digital Input Terminal S4 Function Selection	Term S4 Func Sel	Assigns a function to the multi-function digital inputs. Refer to pages 222 to 223 for descriptions of setting values. <b>Note:</b> Set unused terminals to F.	Default: 14 Min.: 0 Max.: 9F	222
H1-05 (0402)	Multi-Function Digital Input Terminal S5 Function Selection	Term S5 Func Sel	Assigns a function to the multi-function digital inputs. Refer to pages 222 to 223 for descriptions of setting values. <b>Note:</b> Set unused terminals to F.	Default: 8D (0) </> Min.: 0 Max.: 9F	222
H1-06 (0403)	Multi-Function Digital Input Terminal S6 Function Selection	Term S6 Func Sel	Assigns a function to the multi-function digital inputs. Refer to pages 222 to 223 for descriptions of setting values. <b>Note:</b> Set unused terminals to F.	Default: 80 (3) </> Min.: 0 Max.: 9F	222
H1-07 (0404)	Multi-Function Digital Input Terminal S7 Function Selection	Term S7 Func Sel	Assigns a function to the multi-function digital inputs. Refer to pages 222 to 223 for descriptions of setting values. <b>Note:</b> Set unused terminals to F.	Default: 81 (4) </> Min.: 0 Max.: 9F	222
H1-08 (0405)	Multi-Function Digital Input Terminal S8 Function Selection	Term S8 Func Sel	Assigns a function to the multi-function digital inputs. Refer to pages 222 to 223 for descriptions of setting values. <b>Note:</b> Set unused terminals to F.	Default: F (6) </> Min.: 0 Max.: 9F	222
H1-21 (02D7) [RUN]	External Fault 1 Delay Time	EF1 Delay Time	Sets the amount of time delay applied to the EF1 fault. (20 ≤ H1-01 ≤ 2F)	Default: 0.00 s Min.: 0.00 Max.: 300.00	–
H1-22 (02D8) [RUN]	External Fault 2 Delay Time	EF2 Delay Time	Sets the amount of time delay applied to the EF2 fault. (20 ≤ H1-02 ≤ 2F)	Default: 0.00 s Min.: 0.00 Max.: 300.00	–
H1-23 (02D9) [RUN]	External Fault 3 Delay Time	EF3 Delay Time	Sets the amount of time delay applied to the EF3 fault. (20 ≤ H1-03 ≤ 2F)	Default: 0.00 s Min.: 0.00 Max.: 300.00	–
H1-24 (02DA) [RUN]	External Fault 4 Delay Time	EF4 Delay Time	Sets the amount of time delay applied to the EF4 fault. (20 ≤ H1-04 ≤ 2F)	Default: 0.00 s Min.: 0.00 Max.: 300.00	–
H1-25 (02DB) [RUN]	External Fault 5 Delay Time	EF5 Delay Time	Sets the amount of time delay applied to the EF5 fault. (20 ≤ H1-05 ≤ 2F)	Default: 0.00 s Min.: 0.00 Max.: 300.00	–
H1-26 (02DC) [RUN]	External Fault 6 Delay Time	EF6 Delay Time	Sets the amount of time delay applied to the EF6 fault. (20 ≤ H1-06 ≤ 2F)	Default: 0.00 s Min.: 0.00 Max.: 300.00	–
H1-27 (02DD) [RUN]	External Fault 7 Delay Time	EF7 Delay Time	Sets the amount of time delay applied to the EF7 fault. (20 ≤ H1-07 ≤ 2F)	Default: 0.00 s Min.: 0.00 Max.: 300.00	–

## B.8 H Parameters: Multi-Function Terminals

No. (Addr. Hex)	Name	LCD Display	Description	Values	Page
H1-28 (02DE) RUN	External Fault 8 Delay Time	EF8 Delay Time	Sets the amount of time delay applied to the EF8 fault. ( $20 \leq H1-08 \leq 2F$ )	Default: 0.00 s Min.: 0.00 Max.: 300.00	–
H1-31 (09E1) RUN <>	Terminal S1 On-Delay Time	Term S1 On-Delay	Sets the length of time that Terminal S1 must be closed before the drive performs the programmed function.	Default: 0.0 s Min.: 0.0 Max.: 3000.0 <>	–
H1-32 (09E2) RUN <>	Terminal S2 On-Delay Time	Term S2 On-Delay	Sets the length of time that Terminal S2 must be closed before the drive performs the programmed function.	Default: 0.0 s Min.: 0.0 Max.: 3000.0 <>	–
H1-33 (09E3) RUN <>	Terminal S3 On-Delay Time	Term S3 On-Delay	Sets the length of time that Terminal S3 must be closed before the drive performs the programmed function.	Default: 0.0 s Min.: 0.0 Max.: 3000.0 <>	–
H1-34 (09E4) RUN <>	Terminal S4 On-Delay Time	Term S4 On-Delay	Sets the length of time that Terminal S4 must be closed before the drive performs the programmed function.	Default: 0.0 s Min.: 0.0 Max.: 3000.0 <>	–
H1-35 (09E5) RUN <>	Terminal S5 On-Delay Time	Term S5 On-Delay	Sets the length of time that Terminal S5 must be closed before the drive performs the programmed function.	Default: 0.0 s Min.: 0.0 Max.: 3000.0 <>	–
H1-36 (09E6) RUN <>	Terminal S6 On-Delay Time	Term S6 On-Delay	Sets the length of time that Terminal S6 must be closed before the drive performs the programmed function.	Default: 0.0 s Min.: 0.0 Max.: 3000.0 <>	–
H1-37 (09E7) RUN <>	Terminal S7 On-Delay Time	Term S7 On-Delay	Sets the length of time that Terminal S7 must be closed before the drive performs the programmed function.	Default: 0.0 s Min.: 0.0 Max.: 3000.0 <>	–
H1-38 (09E8) RUN <>	Terminal S8 On-Delay Time	Term S8 On-Delay	Sets the length of time that Terminal S8 must be closed before the drive performs the programmed function.	Default: 0.0 s Min.: 0.0 Max.: 3000.0 <>	–
H1-41 (09EB) RUN <>	Terminal S1 Off-Delay Time	Term S1 OffDelay	Sets the length of time needed for Terminal S1 to be open before the drive removes the programmed function.	Default: 0.0 s Min.: 0.0 Max.: 3000.0 <>	–
H1-42 (09EC) RUN <>	Terminal S2 Off-Delay Time	Term S2 OffDelay	Sets the length of time needed for Terminal S2 to be open before the drive removes the programmed function.	Default: 0.0 s Min.: 0.0 Max.: 3000.0 <>	–
H1-43 (09ED) RUN <>	Terminal S3 Off-Delay Time	Term S3 OffDelay	Sets the length of time needed for Terminal S3 to be open before the drive removes the programmed function.	Default: 0.0 s Min.: 0.0 Max.: 3000.0 <>	–
H1-44 (09EE) RUN <>	Terminal S4 Off-Delay Time	Term S4 OffDelay	Sets the length of time needed for Terminal S4 to be open before the drive removes the programmed function.	Default: 0.0 s Min.: 0.0 Max.: 3000.0 <>	–
H1-45 (09EF) RUN <>	Terminal S5 Off-Delay Time	Term S5 OffDelay	Sets the length of time needed for Terminal S5 to be open before the drive removes the programmed function.	Default: 0.0 s Min.: 0.0 Max.: 3000.0 <>	–

No. (Addr. Hex)	Name	LCD Display	Description	Values	Page
H1-46 (09F0) RUN <2>	Terminal S6 Off-Delay Time	Term S6 OffDelay	Sets the length of time needed for Terminal S6 to be open before the drive removes the programmed function.	Default: 0.0 s Min.: 0.0 Max.: 3000.0 <3>	-
H1-47 (09F1) RUN <2>	Terminal S7 Off-Delay Time	Term S7 OffDelay	Sets the length of time needed for Terminal S7 to be open before the drive removes the programmed function.	Default: 0.0 s Min.: 0.0 Max.: 3000.0 <3>	-
H1-48 (09F2) RUN <2>	Terminal S8 Off-Delay Time	Term S8 OffDelay	Sets the length of time needed for Terminal S8 to be open before the drive removes the programmed function.	Default: 0.0 s Min.: 0.0 Max.: 3000.0 <3>	-

<1> Value in parenthesis is the default setting when a 3-Wire initialization is performed (A1-03 = 3330).

<2> Available in drive software versions PRG: 8552 and later. Not available in drive models 4A0930 and 4A1200.

<3> Default is 0.00 s and range is 0.00 to 300.00 in drive software versions PRG: 8553 and earlier.

H1 Multi-Function Digital Input Selections					
H1-□□ Setting	Function	LCD Display	Description	Page	
0	3-Wire sequence	3-Wire Control	Closed: Reverse rotation (only if the drive is set up for 3-Wire sequence) Terminals S1 and S2 are automatically set up for the Run command and Stop command.	-	
2	External Reference 1/2 Selection	External Ref 1/2 Sel	Open: Run command and frequency reference source 1 (determined by b1-01 and b1-02) Closed: Run command and frequency reference source 2 (determined by b1-15 and b1-16)	-	
3	Multi-Step Speed Reference 1	Multi-Step Ref 1	When input terminals are set to Multi-Step Speed References 1 through 3, switching combinations of those terminals will create a multi-step speed sequence using the frequency references set in d1-01 through d1-08.	-	
4	Multi-Step Speed Reference 2	Multi-Step Ref 2	When input terminals are set to Multi-Step Speed References 1 through 3, switching combinations of those terminals will create a multi-step speed sequence using the frequency references set in d1-01 through d1-08.	-	
5	Multi-Step Speed Reference 3	Multi-Step Ref 3	When input terminals are set to Multi-Step Speed References 1 through 3, switching combinations of those terminals will create a multi-step speed sequence using the frequency references set in d1-01 through d1-08.	-	
6	Jog reference selection	jog Freq Ref	Closed: Jog frequency reference (d1-17) selected. Jog has priority over all other reference sources.	-	
7	Accel/decel time selection 1	Multi-Acc/Dec 1	Used to switch between accel/decel time 1 (set in C1-01, C1-02) and accel/decel time 2 (set in C1-03, C1-04).	-	
8	Baseblock command (N.O.)	Ext BaseBlk N.O.	Closed: No drive output	-	
9	Baseblock command (N.C.)	Ext BaseBlk N.C.	Open: No drive output	-	
A	Accel/decel ramp hold	Acc/Dec RampHold	Open: Accel/decel is not held Closed: The drive pauses during acceleration or deceleration and maintains the output frequency.	-	
B	Drive overheat alarm (oH2)	OH2 Alarm Signal	Closed: Closes when an oH2 alarm occurs	-	
C	Analog terminal input selection	Term A2 Enable	Open: Function assigned by H3-14 is disabled. Closed: Function assigned by H3-14 is enabled.	-	
F	Through mode	Term Not Used	Select this setting when using the terminal in a pass-through mode. The terminal does not trigger a drive function but can be used as digital input for the controller the drive is connected to.	-	
10	Up command	Up Command 1	The drive accelerates when the Up command terminal closes, and decelerates when the Down command closes. When both terminals are closed or both are open, the drive holds the frequency reference. The Up and Down commands must always be used in conjunction with one another.	-	

## B.8 H Parameters: Multi-Function Terminals

H1 Multi-Function Digital Input Selections				
H1-□□ Setting	Function	LCD Display	Description	Page
11	Down command	Down Command 1	The drive accelerates when the Up command terminal closes, and decelerates when the Down command closes. When both terminals are closed or both are open, the drive holds the frequency reference. The Up and Down commands must always be used in conjunction with one another.	–
12	Forward Jog	Forward Jog	Closed: Runs forward at the Jog frequency d1-17.	–
13	Reverse Jog	Reverse Jog	Closed: Runs reverse at the Jog frequency d1-17.	–
14	Fault reset	Fault Reset	Closed: Resets faults if the cause is cleared and the Run command is removed.	–
15	Fast Stop (N.O.)	Fast-Stop N.O.	Closed: Decelerates at the Fast Stop time set to C1-09.	–
17	Fast Stop (N.C.)	Fast-Stop N.C.	Open: Decelerates to stop at the Fast Stop time set to C1-09.	–
18	Timer function input	Timer function	Triggers the timer set up by parameters b4-01 and b4-02. Must be set in conjunction with the timer function output (H2-□□ = 12).	–
19	PID disable	PID Disable	Open: PID control enabled Closed: PID control disabled	–
1A	Accel/decel time selection 2	Multi-Acc/Dec 2	Used in conjunction with an input terminal set for “Accel/decel time selection 1” (H1-□□ = 7), and allows the drive to switch between accel/decel times 3 and 4.	–
1B	Program lockout	Program Lockout	Open: Parameters cannot be edited (except for U1-01 if the reference source is assigned to the digital operator). Closed: Parameters can be edited and saved.	–
1E	Reference sample hold	Ref Sample Hold	Closed: Samples the analog frequency reference and operates the drive at that speed.	–
20 to 2F	External pump fault	Ext Pump Fault 20: NO/Always Det, Ramp to Stop 21: NC/Always Det, Ramp to Stop 22: NO/During RUN, Ramp to Stop 23: N.C., During RUN, Ramp to Stop 24: NO/ Always Det, Coast to Stop 25: NC/Always Det, Coast to Stop 26: NO/During RUN, Coast to Stop 27: NC/During RUN, Coast to Stop 28: NO/Always Det, Fast-Stop 29: NC/Always Det, Fast-Stop 2A: NO/During RUN, Fast-Stop 2B: NC/During RUN, Fast- Stop 2C: NO/Always Det, Alarm Only 2D: NC/Always Det, Alarm Only 2E: NO/ During RUN, Alarm Only 2F: NC/During RUN, Alarm Only	20: N.O., Always detected, ramp to stop 21: N.C., Always detected, ramp to stop 22: N.O., During run, ramp to stop 23: N.C., During run, ramp to stop 24: N.O., Always detected, coast to stop 25: N.C., Always detected, coast to stop 26: N.O., During run, coast to stop 27: N.C., During run, coast to stop 28: N.O., Always detected, Fast Stop 29: N.C., Always detected, Fast Stop 2A: N.O., During run, Fast Stop 2B: N.C., During run, Fast Stop 2C: N.O., Always detected, alarm only (continue running) 2D: N.C., Always detected, alarm only (continue running) 2E: N.O., During run, alarm only (continue running) 2F: N.C., During run, alarm only (continue running)	–
30	PID integral reset	PID Intgrl Reset	Closed: Resets the PID control integral value.	–
31	PID integral hold	PID Intgrl Hold	Open: Performs integral operation. Closed: Maintains the current PID control integral value.	–
32	Multi-Step Speed Reference 4	Multi-Step Ref 4	Used in combination with input terminals set to Multi-Step Speed Reference 1, 2, and 3. Use parameters d1-09 to d1-16 to set reference values.	–
34	PID soft starter cancel	PID SFS Cancel	Open: PID soft starter is enabled. Closed: Disables the PID soft starter b5-17.	–
35	PID input level selection	PID Input Invert	Closed: Inverts the PID input signal.	–



H1 Multi-Function Digital Input Selections				
H1-□□ Setting	Function	LCD Display	Description	Page
40	Forward run command (2-Wire sequence)	FwdRun 2Wire Seq	Open: Stop Closed: Forward run <b>Note:</b> Cannot be set together with settings 42 or 43.	–
41	Reverse run command (2-Wire sequence)	RevRun 2WireSeq	Open: Stop Closed: Reverse run <b>Note:</b> Cannot be set together with settings 42 or 43.	–
42	Run command (2-Wire sequence 2)	Run/Stp 2WireSeq	Open: Stop Closed: Run <b>Note:</b> Cannot be set together with settings 40 or 41.	–
43	FWD/REV command (2-Wire sequence 2)	FWD/REV 2WireSeq	Open: Forward Closed: Reverse <b>Note:</b> Determines motor direction, but does not issue a Run command. Cannot be set together with settings 40 or 41.	–
47	Node setup	CanOpenNID Setup	Closed: Node setup for SI-S3 enabled.	–
51	Sequence Timer Disable	SeqTimer Disable	Closed: Drive ignores sequence timers and runs normally (based on b1-02/b1-16 source).	–
52	Sequence Timer Cancel	SeqTimer Cancel	Closed: When the input changes from open to closed, the currently active sequence timer is disabled. Operation will resume with the next scheduled sequence timer. Cycling the Run command after the current sequence timer has been canceled will re-enable the sequence timer.	–
60	DC Injection Braking command	DCInj Activate	Closed: Triggers DC Injection Braking.	–
61	External Speed Search command 1	Speed Search 1	Closed: Activates Current Detection Speed Search from the maximum output frequency (E1-04).	–
62	External Speed Search command 2	Speed Search 2	Closed: Activates Current Detection Speed Search from the frequency reference.	–
63	Field weakening	Field Weak	Closed: The drive performs Field Weakening control as set for d6-01 and d6-02.	–
65	KEB Ride-Thru 1 (N.C.)	KEB Ridethru NC	Open: KEB Ride-Thru 1 enabled.	–
66	KEB Ride-Thru 1 (N.O.)	KEB Ridethru NO	Closed: KEB Ride-Thru 1 enabled.	–
67	Communications test mode	Comm Test Mode	Tests the MEMOBUS/Modbus RS-422/RS-485 interface. Displays “PASS” if the test completes successfully.	–
68	High Slip Braking (HSB)	HighSlipBraking	<b>V/f</b> Closed: Activates High Slip Braking to stop the drive during a Run command.	–
6A	Drive enable	Drive Enable	Open: Drive disabled. If this input is opened during run, the drive will stop as specified by b1-03. Closed: Ready for operation.	–
73	Low City Press	Low City Press	Indicates that sufficient or insufficient pressure is present on the inlet to the pump. Used mainly for pressure booster situations. <b>Note:</b> Parameter P4-21 determines if this input is normally open or normally closed.	–
75	Up 2 command	Up Command 2	Controls the bias added to the frequency reference by the Up/Down 2 function. The Up 2 and Down 2 commands must always be used in conjunction with one another.	–
76	Down 2 command	Down Command 2	Controls the bias added to the frequency reference by the Up/Down 2 function. The Up 2 and Down 2 commands must always be used in conjunction with one another.	–
7A	KEB Ride-Thru 2 (N.C.)	KEB Ridethru2NC	Open: KEB Ride-Thru 2 enabled. Drive disregards L2-29 and performs Single Drive KEB Ride-Thru 2.	–
7B	KEB Ride-Thru 2 (N.O.)	KEB Ridethru2NO	Closed: KEB Ride-Thru 2 enabled. Drive disregards L2-29 and performs Single Drive KEB Ride-Thru 2.	–
7F	PID Bi-Direction Enable	PID BiDir Enable	PID Bi-Direction Enable	–
80	HAND Mode	Hand Mode	Closed: HAND Mode operation. Frequency reference determined by P5-01 and P5-02. Open: Stop Mode when no Run command.	–
81	HAND Mode 2	Hand Mode 2	Closed: HAND Mode operation. Frequency reference determined by P5-05. Open: Stop Mode when no Run command.	–

## B.8 H Parameters: Multi-Function Terminals

H1 Multi-Function Digital Input Selections				
H1-□□ Setting	Function	LCD Display	Description	Page
82 <>	PI Switch to Aux	PI Switch to Aux	Closed: PI Auxiliary Control (Q6-□□) becomes the primary PI loop, disabling the System PI controller (b5-□□). Overrides Q6-20 whenset to 0 (Disable Effect on Speed Control).	–
83	Alternate Multi Setpoint (Q1-02)	AltMultiSP Q1-02	Closed: Q1-02 becomes the PID setpoint	–
84	Alternate Multi Setpoint (Q1-03)	AltMultiSP Q1-03	Closed: Q1-03 becomes the PID setpoint	–
85	Alternate Multi Setpoint (Q1-04)	AltMultiSP Q1-04	Closed: Q1-04 becomes the PID setpoint	–
88	Volute-Thermostat Normally Open	Volute-TStat NO	Function active when the drive is running. Closed: Drive will trip on “VLTS - Volute-TStat Flt” Open: Thermostat fault not active <b>Note:</b> Setting H1-□□ = 88 and 89 simultaneously will trigger a “VLTS - Volute-TStat Flt”.	–
89	Volute-Thermostat Normally Closed	Volute-TStat NC	Function active when the drive is running. Closed: Thermostat fault not active Open: Drive will trip on “VLTS - Volute-TStat Flt” <b>Note:</b> Setting H1-□□ = 88 and 89 simultaneously will trigger a “VLTS - Volute-TStat Flt”.	–
8C	Disable Pre-Charge	Disable Pre-Chrg	Closed: Pre-Charge disabled.	–
8D	Multi Setpoint 1	Multi Setpoint 1	Open: Frequency reference, Q1-01, or Q1-03 is PID Setpoint. Closed: Q1-02 or Q1-04 is PID Setpoint.	–
8E	Multi Setpoint 2	Multi Setpoint 2	Open: Frequency reference, Q1-01, or Q1-02 is PID Setpoint. Closed: Q1-03 or Q1-04 is PID Setpoint.	–
8F	Low Water Level	Low Water	Function active in AUTO Mode during normal operation, also used with Pre-Charge function. Function logic depends on P1-30, Low Water Digital Input Configuration. P1-30 = 0 (Normally open) Closed: Low water level fault Open: Reservoir/Tank is filled to normal level P1-30 = 1 (Normally closed) Closed: Reservoir/Tank is filled to normal level Open: Low water level fault Pre-Charge function: Function uses the low water level input as “Tank/Reservoir” feedback to indicate that the water level has been reached.	–
90	High Water Level	High Water	Function active when the drive is running. Function logic depends on P1-31, High Water Digital Input Configuration. P1-31 = 0 (Normally open) Closed: High water level fault Open: Reservoir/Tank is filled to normal level P1-31 = 1 (Normally closed) Closed: Reservoir/Tank is filled to normal level Open: High water level fault	–
92	Reset Accumulated Volume	Reset Accum	Closed: Accumulated volume is reset to 0 and held at 0 if digital input remains closed.	–
95	Remove Drive Disable	Remote Drv Disbl	Closed: Prevents the drive from running when active for the time set in P4-26. Must be inactive for the time set in P4-27 to allow the drive to run again. <b>Note:</b> Parameter P4-25 determines if this input is normally open or normally closed.	–
A8	Secondary PI Disable (N.O.)	PI2 Disable N.O.	Closed: Disables the secondary PI controller. Output behavior depends on the setting of S3-12.	–
A9	Secondary PI Disable (N.C.)	PI2 Disable N.C.	Closed: Enables the secondary PI controller. Output behavior depends on the setting of S3-12 when open.	–
AA	Secondary PI Inverse Operation	PI2 Invert	Closed: Changes the sign of the secondary PI controller input (reverse acting PI control).	–
AB	Secondary PI Integral Reset	PI2 Intgrl Reset	Closed: Resets the secondary PI controller integral value.	–
AC	Secondary PI Integral Hold	PI2 Intgrl Hold	Closed: Locks the value of the secondary PI controller integral value.	–

H1 Multi-Function Digital Input Selections				
H1-□□ Setting	Function	LCD Display	Description	Page
AD	Select Secondary PI Parameters	Select PI2 Parm	Closed: Uses the secondary PI controller Proportional and Integral adjustments (S3-06 and S3-07) instead of the primary PI controller Proportional and Integral adjustments (b5-02 and b5-03). Only valid when S3-01 = 0 (secondary PI controller disabled). <b>Note:</b> This multi-function input has no effect on the secondary PI controller. It is only used for the primary PI controller (b5-□□).	–
AF	Emergency Override Forward Run	EmergOverrideFWD	Closed: Run the drive forward using the speed set in S6-02.	–
B0	Emergency Override Reverse Run	EmergOverrideREV	Closed: Run the drive in reverse using the speed set in S6-02.	–

<1> Available in drive software versions PRG: 8552 and later. Not available in drive models 4A0930 and 4A1200.

## ◆ H2: Multi-Function Digital Outputs

No. (Addr. Hex)	Name	LCD Display	Description	Values	Page
H2-01 (040B)	Terminal M1-M2 function selection (relay)	M1-M2 Func Sel	Refer to H2 Multi-Function Digital Output Settings on pages 224 to 224 for descriptions of setting values.	Default: 37 Range: 0 to 1AC	223
H2-02 (040C)	Terminal M3-M4 function selection (relay)	M3/M4 Func Sel		Default: 42 <1> Range: 0 to 1AC	223
H2-03 (040D)	Terminal MD-ME-MF Function Selection	MD/ME/MF Func Sel		Default: E Range: 0 to 1AC	223
H2-06 (0437)	Watt Hour Output Unit Selection	Pwr Mon Unit Sel	Outputs a 200 ms pulse signal when the watt-hour counter increases by the units selected. 0: 0.1 kWh units 1: 1 kWh units 2: 10 kWh units 3: 100 kWh units 4: 1000 kWh units	Default: 0 Range: 0 to 4	–
H2-31 (09D1) <2>	Terminal M1/M2 On-Delay Time M1/M2 On	M1/M2 On Delay	Sets the amount of time needed for the programmed function (H2-01) to be active before M1/M2 closes.	Default: 0.0 s Range: 0.0 to 3000.0	–
H2-32 (09D2) <2>	Terminal M3/M4 On-Delay Time	M3/M4 On Delay	Sets the amount of time needed for the programmed function (H2-02) to be active before M3/M4 closes.	Default: 0.0 s Range: 0.0 to 3000.0	–
H2-33 (09D3) <2>	Terminal MD/ME/MF On-Delay Time	MD/ME/MF OnDelay	Sets the amount of time needed for the programmed function (H2-03) to be active before MD/MF closes, or ME/MF opens.	Default: 0.0 s Range: 0.0 to 3000.0	–
H2-41 (09D9) <2>	Terminal M1/M2 Off-Delay Time	M1/M2 Off Delay	Sets the amount of time needed for the programmed function (H2-01) to be inactive before M1/M2 opens.	Default: 0.0 s Range: 0.0 to 3000.0	–
H2-42 (09DA) <2>	Terminal M3/M4 Off-Delay Time	M3/M4 Off Delay	Sets the amount of time needed for the programmed function (H2-02) to be inactive before M3/M4 opens.	Default: 0.0 s Range: 0.0 to 3000.0	–
H2-43 (09DB) <2>	Terminal MD/ME/MF Off-Delay Time	MD/ME/MF Off Dly	Sets the amount of time needed for the programmed function (H2-03) to be inactive before MD/MF opens, or ME/MF closes.	Default: 0.0 s Range: 0.0 to 3000.0	–

<1> Default is F in drive software versions PRG: 8551 and earlier.

<2> Available in drive software versions PRG: 8554 and later. Not available in drive models 4A0930 and 4A1200.

H2 Multi-Function Digital Output Settings				
H2-□□ Setting	Function	LCD Display	Description	Page
0	During run	During RUN 1	Closed: A Run command is active or voltage is output.	–
1	Zero speed	Zero Speed	Open: Output frequency is above the minimum output frequency set in E1-09. Closed: Output frequency is below the minimum output frequency set in E1-09.	–

## B.8 H Parameters: Multi-Function Terminals

H2 Multi-Function Digital Output Settings				
H2-□□ Setting	Function	LCD Display	Description	Page
2	Speed agree 1	Fref/Fout Agree1	Closed: Output frequency equals the speed reference (plus or minus the hysteresis set to L4-02).	
3	User-set speed agree 1	Fref/Set Agree 1	Closed: Output frequency and speed reference equal L4-01 (plus or minus the hysteresis set to L4-02).	
4	Frequency detection 1	Freq Detect 1	Closed: Output frequency is less than or equal to the value in L4-01 with hysteresis determined by L4-02.	–
5	Frequency detection 2	Freq Detect 2	Closed: Output frequency is greater than or equal to the value in L4-01 with hysteresis determined by L4-02.	–
6	Drive ready	Drive Ready	Closed: Power up is complete and the drive is ready to accept a Run command.	–
7	DC bus undervoltage	DC Bus Undervolt	Closed: DC bus voltage is below the Uv trip level set in L2-05.	–
8	During baseblock (N.O.)	BaseBlk 1	Closed: Drive has entered the baseblock state (no output voltage).	–
9	Frequency reference source	Ref Source	Open: External Reference 1 or 2 supplies the frequency reference (set in b1-01 or b1-15). Closed: Digital operator supplies the frequency reference.	–
A <F>	Run command source	Run Cmd Source	Open: External Reference 1 or 2 supplies the Run command (set in b1-02 or b1-16). Closed: Digital operator supplies the Run command.	–
A <D>	HAND Mode	Hand Mode	Closed: Pump is in HAND Mode Operation	–
B	Torque detection 1 (N.O.)	Trq Det 1 N.O.	Closed: An overtorque or undertorque situation has been detected.	–
C	Frequency reference loss	Loss of Ref	Closed: Analog frequency reference has been lost. Frequency reference loss is detected when the frequency reference drops below 10% of the reference within 400 ms.	–
D	Braking resistor fault	DB Overheat	Closed: Braking resistor or transistor is overheated or faulted out. <b>Note:</b> This setting is not available in models 4A0930 and 4A1200.	–
E	Fault	Fault	Closed: Fault occurred.	–
F <D>	Through mode	Not Used	Set this value when using the terminal in the pass-through mode.	–
10	Minor fault	Minor Fault	Closed: An alarm has been triggered, or the IGBTs have reached 90% of their expected life span.	–
11	Fault reset command active	Reset Cmd Active	Closed: A command has been entered to clear a fault via the input terminals or from the serial network.	–
12	Timer output	Timer Output	Closed: Timer output.	–
13	Speed agree 2	Fref/Fout Agree2	Closed: When drive output frequency equals the frequency reference $\pm$ L4-04. <b>Note:</b> This setting is not available in models 4A0930 and 4A1200.	–
14	User-set speed agree 2	Fref/Set Agree 2	Closed: When the drive output frequency is equal to the value in L4-03 $\pm$ L4-04.	–
15	Frequency detection 3	Freq Detect 3	Closed: When the drive output frequency is less than or equal to the value in L4-03 $\pm$ L4-04.	–
16	Frequency detection 4	Freq Detect 4	Closed: When the output frequency is greater than or equal to the value in L4-03 $\pm$ L4-04.	–
17	Torque detection 1 (N.C.)	Trq Det 1 N.C.	Open: Overtorque or undertorque has been detected.	
18	Torque detection 2 (N.O.)	Trq Det 2 N.O.	Closed: Overtorque or undertorque has been detected.	–
19	Torque detection 2 (N.C.)	Trq Det 2 N.C.	Open: Overtorque or undertorque has been detected.	–
1A	During reverse	Reverse Dir	Closed: Drive is running in the reverse direction.	–
1B	During baseblock (N.C.)	BaseBlk 2	Open: Drive has entered the baseblock state (no output voltage).	–
1E	Restart enabled	Dur Flt Restart	Closed: An automatic restart is performed	–
1F	Motor overload alarm (oL1)	Overload (OL1)	Closed: oL1 is at 90% of its trip point or greater. An oH3 situation also triggers this alarm.	–
20	Drive overheat pre-alarm (oH)	OH Prealarm	Closed: Heatsink temperature exceeds the parameter L8-02 value.	–
22	Mechanical weakening detection	MechFatigue(OL5)	Closed: Mechanical weakening detected.	–

H2 Multi-Function Digital Output Settings				
H2-□□ Setting	Function	LCD Display	Description	Page
2F	Maintenance period	Maintenance	Closed: Cooling fan, electrolytic capacitors, IGBTs, or the soft charge bypass relay may require maintenance.	–
30	During torque limit	Torque Limit	<b>OLV</b> Closed: The torque limit has been reached.	225
37	During frequency output	During RUN 2	Open: Either the drive has stopped or baseblock, DC Injection Braking, or Initial Excitation is being performed. Closed: Drive is running the motor (not in a baseblock state and DC Injection is not being performed).	–
38	Drive enabled	Drive Enable	Closed: Multi-function input set for “Drive enable” is closed (H1-□□ = 6A)	–
39	Watt hour pulse output	Watt-hour Pulse	Output units are determined by H2-06. Outputs a pulse every 200 ms to indicate the kWh count.	–
3D	During speed search	During SpdSrch	Closed: Speed Search is being executed.	–
3E	PID feedback low	PID Feedback Low	Closed: PID feedback level is too low.	–
3F	PID feedback high	PID FeedbackHigh	Closed: The PID feedback level is too high.	–
40 <2>	Auto Mode	Auto Mode	Closed: Pump is in AUTO Mode Operation.	–
42 <2>	Pressure Reached	Pressure Reached	Pressure Setpoint has been reached. Activation and deactivation conditions based on the Pressure Feedback and the settings of P4-36 to P4-40.	225
43 <2>	2 Motor Alternate	2Motor Alternate	Used in conjunction with the 2-motor alternation function. Open: Motor 1 in use. (or 2-motor alternation is disabled) Closed: Motor 2 in use.	–
4A	During KEB Ride-Thru	During KEB	Closed: KEB Ride-Thru is being performed.	–
4C	During fast stop	During Fast Stop	Closed: A Fast Stop command has been entered from the operator or input terminals.	–
4D	oH Pre-alarm time limit	OH Pre-Alarm	Closed: oH pre-alarm time limit has passed.	–
4E	Braking transistor fault (rr)	Brk Trans Fault	Closed: The built-in dynamic braking transistor failed. <b>Note:</b> This setting is not available in models 2A0169 to 2A0415 and 4A0088 to 4A1200.	–
4F	Braking resistor overheat (oH)	BrkResistOvHeat	Closed: The dynamic braking resistor has overheated. <b>Note:</b> This setting is not available in models 2A0169 to 2A0415 and 4A0088 to 4A1200.	–
51	Sequence timer 1	SeqTimer Disable	Closed: Sequence timer 1 is active.	–
52	Sequence timer 2	SeqTimer Cancel	Closed: Sequence timer 2 is active.	–
53	Sequence timer 3	Sequence timer 3	Closed: Sequence timer 3 is active.	–
54	Sequence timer 4	Sequence Timer 4	Closed: Sequence timer 4 is active.	–
58	Underload detection	UL6	Closed: Underload is detected.	–
60	Internal cooling fan alarm	Fan Alrm Det	Closed: Internal cooling fan alarm	–
71	Secondary PI Feedback Low	PI2 Feedback Low	Closed: PI2 feedback level is too low.	–
72	Secondary PI Feedback High	PI2 FeedbackHigh	Closed: The PI2 feedback level is too high.	–
80	Pump 2 Control	Pump 2 Control	Contactora control for a second pump. The function is active in contactora multiplex mode only (P1-01 = 1).	–
81	Pump 3 Control	Pump 3 Control	Contactora control for a third pump. The function is active in contactora multiplex mode only (P1-01 = 1) and when P3-01 is set to a value greater than 1.	–
82	Pump 4 Control	Pump 4 Control	Contactora control for a fourth pump. The function is active in contactora multiplex mode only (P1-01 = 1) and when P3-01 is set to a value greater than 2.	–
83	Pump 5 Control	Pump 5 Control	Contactora control for a fifth pump. The function is active in contactora multiplex mode only (P1-01 = 1) and when P3-01 is set to a value greater than 3.	–
84	Pump 6 Control	Pump 6 Control	Contactora control for a sixth pump. The function is active in contactora multiplex mode only (P1-01 = 1) and when P3-01 is set to a value greater than 4.	–

## B.8 H Parameters: Multi-Function Terminals

H2 Multi-Function Digital Output Settings				
H2-□□ Setting	Function	LCD Display	Description	Page
89	Output I Limit	Output I Lim	Closed: Drive output speed is being limited due to the output current limit or the single phase foldback regulator.	–
8B	Lube Pump or Digital Output Delay	Lube Pump or DigitalOutput Delay	Closed: Refer to Lube Pump / Digital Output Delay parameters P4-30 and P4-31. Display text is set by parameter P4-29.	–
8F	Internal Fan On	Internal Fan On	Internal Fan On	–
91	Pump Fault	Pump Fault	Closed when any of the following faults are active: <ul style="list-style-type: none"> <li>• Low feedback</li> <li>• High feedback</li> <li>• Low water</li> <li>• High water</li> <li>• NMS-Setpoint not met</li> <li>• POC-Pump over cycle</li> <li>• External pump fault</li> </ul>	–
92	Transducer Loss	Transducer Loss	Closed: The analog output associated with PID feedback has risen above 21 mA or fallen below 3 mA or a Transducer Loss alarm or fault is active.	–
93	Setpoint Not Met	SetPoint Not Met	Closed: During an “NMS-Setpoint Not Met” condition.	–
94	Loss of Prime	Loss of Prime	Closed: During an “LOP-Loss of Prime” condition.	–
95	Volute Thermostat Fault	Volute-TStat Flt	Closed: Volute-Thermostat digital input is active.	–
96	High Feedback	High Feedback	Closed: During a “High Feedback” condition as defined by P1-11 and P1-12 OR Closed: During a “High FB/Water” fault OR Closed: During a “High Feedback” alarm	–
97	Low Feedback	Low Feedback	Closed: During a “Low Feedback” condition as defined by P1-08 and P1-12 OR Closed: During a “Low FB/Water” fault OR Closed: During a “Low Feedback” alarm	–
98	Low Flow	Low Flow	Closed: During the “Low Flow Fault” condition OR Closed: During a Low Flow condition set by P6-06 to P6-08, including a “Low Flow” alarm	–
99	Accum Level	Accum Level	Closed: Accumulated level has exceeded the P6-11 to P6-14 settings OR Closed: During the “Accum Level” fault	–
9A	High Flow	High Flow	Closed: During the “High Flow Fault” condition OR Closed: During a “High Flow” condition set by P6-17 and P6-18, including a “High Flow” alarm	–
9B	Low Water Level	Low Water Level	Closed: The water level has dropped below the Low Detection Level set in Q4-09.	–
9C	Low Suction	Low Suction	Closed: The suction pressure has dropped below the Low Suction Pressure Detection Level set in Q5-09.	–
9D	High Suction	High Suction	Closed: The suction pressure has risen above the High Suction Pressure Detection Level set in Q5-12.	–
9E <>	Low PI Aux Level	Low PI Aux Lvl	Energizes when the PI Aux Feedback Level drops below the Low PI Aux Level (Q6-09), or if there is a LOAUX – Low PI Aux Level Fault.	–
9F <>	High PI Aux Level	High PI Aux Lvl	Energizes when the PI Aux Feedback Level rises above the High PI Aux Level (Q6-12), or if there is a HIAUX – Hi PI Aux Lvl Fault.	–
A0 <>	Water Loss/Suction Pressure/PI Aux Control	WL/SP/PIAux Ctrl	Closed when the Water Level, Suction Pressure, or PI Auxiliary Controller is affecting the output speed.	–
A1 <>	Differential Detected	Differential Det	Closed: The difference between the PID Feedback and the Differential Feedback (H3-□□ = 28) exceeded the P4-18 level for the time set in P4-19.	–
A2	Sleep Active	Sleep Active	Closed: The drive is not running due to the Sleep function (does not include Sleep Boost).	–
A3	Start Delay	Start Delay	Closed: Feedback has risen above the start level (or fallen below for Inverse PID) and the start timer is timing.	–
A4	Pre-Charge	Pre-Chg Active	Closed: Drive is in Pre-Charge mode.	–
A5	Anti-Jam Active	Anti-Jam Active	Closed: The anti-jam function is active (configured by P7-□□).	–
A6 <>	De-Scale Active	De-Scale Active	Closed: De-scale is running.	–
A7 <>	Flow Rate Limit	Flow Rate Limit	Closed: The Flow Rate is actively affecting the output speed.	–
A9	Thrust Mode	Thrust Mode	Closed: The Thrust Bearing feature is active (output frequency is between 0 and the value of P4-12).	–

H2 Multi-Function Digital Output Settings				
H2-□□ Setting	Function	LCD Display	Description	Page
AA	Utility Start Delay	Utility Delay	Closed: The drive is stopped and waiting for the utility delay timer set in P4-17 to expire.	–
AB	Main Feedback Lost	Main FdBk Lost	Closed: Main feedback is lost.	–
AC	Backup Feedback Lost	Backup FdBk Lost	Closed: Backup feedback is lost.	–
100 to 1AC	Function 0 to AC with inverse output	–	Inverts the output switching of the multi-function output functions. Set the last two digits of 1□□ to reverse the output signal of that specific function.	–

<1> Available in drive software versions PRG: 8551 and earlier.

<2> Available in drive software versions PRG: 8552 and later. Not available in drive models 4A0930 and 4A1200.

### ◆ H3: Multi-Function Analog Inputs

No. (Addr. Hex)	Name	LCD Display	Description	Values	Page
H3-01 (0410)	Terminal A1 Signal Level Selection	Term A1 Level 0: 0-10V, (LowLim=0) 1: 0-10V, (BipolRef) 2: 4-20 mA 3: 0-20 mA	0: 0 to 10 V 1: -10 to 10 V 2: 4 to 20 mA 3: 0 to 20 mA  <b>Note:</b> Use Jumper S1 to set input terminal A1 for a current or voltage input signal.	Default: 0 Range: 0 to 3	225
H3-02 (0434)	Terminal A1 Function Selection	Term A1 FuncSel	Sets the function of terminal A1.	Default: 0 Range: 0 to 32	225
H3-03 (0411) [RUN]	Terminal A1 Gain Setting	Terminal A1 Gain	Sets the level of the input value selected in H3-02 when 10 V is input at terminal A1.	Default: 100.0% Min.: -999.9 Max.: 999.9	225
H3-04 (0412) [RUN]	Terminal A1 Bias Setting	Terminal A1 Bias	Sets the level of the input value selected in H3-02 when 0 V is input at terminal A1.	Default: 0.0% Min.: -999.9 Max.: 999.9	225
H3-05 (0413)	Terminal A3 Signal Level Selection	Term A3 Level 0: 0-10V, (LowLim=0) 1: 0-10V, (BipolRef) 2: 4-20 mA 3: 0-20 mA	0: 0 to 10 V 1: -10 to 10 V 2: 4 to 20 mA 3: 0 to 20 mA  <b>Note:</b> Use Jumper S1 to set input terminal A3 for a current or voltage input signal.	Default: 0 Range: 0 to 3	226
H3-06 (0414)	Terminal A3 Function Selection	Term A3 FuncSel	Sets the function of terminal A3.	Default: 20 Range: 0 to 32	226
H3-07 (0415) [RUN]	Terminal A3 Gain Setting	Terminal A3 Gain	Sets the level of the input value selected in H3-06 when 10 V is input at terminal A3.	Default: 100.0% Min.: -999.9 Max.: 999.9	227
H3-08 (0416) [RUN]	Terminal A3 Bias Setting	Terminal A3 Bias	Sets the level of the input value selected in H3-06 when 0 V is input at terminal A3.	Default: 0.0% Min.: -999.9 Max.: 999.9	227
H3-09 (0417)	Terminal A2 Signal Level Selection	Term A2 Level 0: 0-10V, (LowLim=0) 1: 0-10V, (BipolRef) 2: 4-20 mA 3: 0-20 mA	0: 0 to 10 V 1: -10 to 10 V 2: 4 to 20 mA 3: 0 to 20 mA  <b>Note:</b> Use Jumper S1 to set input terminal A2 for a current or voltage input signal.	Default: 2 Range: 0 to 3	227
H3-10 (0418)	Terminal A2 Function Selection	Term A2 FuncSel	Sets the function of terminal A2.	Default: B Range: 0 to 32	227
H3-11 (0419) [RUN]	Terminal A2 Gain Setting	Terminal A2 Gain	Sets the level of the input value selected in H3-10 when 10 V (20 mA) is input at terminal A2.	Default: 100.0% Min.: -999.9 Max.: 999.9	227
H3-12 (041A) [RUN]	Terminal A2 Bias Setting	Terminal A2 Bias	Sets the level of the input value selected in H3-10 when 0 V (0 or 4 mA) is input at terminal A2.	Default: 0.0% Min.: -999.9 Max.: 999.9	227

## B.8 H Parameters: Multi-Function Terminals

No. (Addr. Hex)	Name	LCD Display	Description	Values	Page
H3-13 (041B)	Analog Input Filter Time Constant	A1/A2 Filter T	Sets a primary delay filter time constant for terminals A1, A2, and A3. Used for noise filtering.	Default: 0.03 s Min.: 0.00 Max.: 2.00	–
H3-14 (041C)	Analog Input Terminal Enable Selection	A1/A2/A3 Sel 1: A1 Available 2: A2 Available 3: A1/A2 Available 4: A3 Available 5: A1/A3 Available 6: A2/A3 Available 7: All Available	Determines which analog input terminals will be enabled when a digital input programmed for “Analog input enable” (H1-□□ = C) is activated. 1: Terminal A1 only 2: Terminal A2 only 3: Terminals A1 and A2 only 4: Terminal A3 only 5: Terminals A1 and A3 6: Terminals A2 and A3 7: All terminals enabled	Default: 7 Range: 1 to 7	–
H3-16 (02F0)	Terminal A1 Offset	TerminalA1Offset	Adds an offset when the analog signal to terminal A1 is at 0 V.	Default: 0 Min.: -500 Max.: 500	–
H3-17 (02F1)	Terminal A2 Offset	TerminalA2Offset	Adds an offset when the analog signal to terminal A2 is at 0 V.	Default: 0 Min.: -500 Max.: 500	–
H3-18 (02F2)	Terminal A3 Offset	TerminalA3Offset	Adds an offset when the analog signal to terminal A3 is at 0 V.	Default: 0 Min.: -500 Max.: 500	–

### H3 Multi-Function Analog Input Settings

H3-□□ Setting	Function	LCD Display	Description	Page
0	Frequency bias	Freq Ref Bias	10 V = E1-04 (maximum output frequency)	–
1	Frequency gain	Freq Ref Gain	0 to 10 V signal allows a setting of 0 to 100%. -10 to 0 V signal allows a setting of -100 to 0%.	–
2	Auxiliary frequency reference 1	Aux Reference1	10 V = E1-04 (maximum output frequency)	–
3	Auxiliary frequency reference 2	Aux Reference2	10 V = E1-04 (maximum output frequency)	–
4	Output voltage bias	Voltage Bias	<b>V/f</b> 10 V = E1-05 (motor rated voltage)	–
5	Accel/decel time gain	Acc/DecTime Change	10 V = 100%	–
6	DC Injection Braking current	DC Brake Current	10 V = Drive rated current	–
7	Overtorque/ undertorque detection level	Torque Det Level	10 V = Drive rated current (V/f)	–
8	Stall Prevention level during run	Stall Prev Level	<b>V/f</b> 10 V = Drive rated current	–
9	Output frequency lower limit level	Ref Lower Limit	10 V = E1-04 (maximum output frequency)	–
B	PID feedback	PID Feedback1	10 V = 100%	–
C	PID setpoint	PID Set Point	10 V = 100%	–
D	Frequency bias	Freq Ref Bias 2	10 V = E1-04 (maximum output frequency)	–
E	Motor Temperature (PTC Input)	Motor PTC	10 V = 100% <b>Note:</b> A 12 kΩ resistor must be connected between terminals A1, A2, or A3 and V+ for PTC functionality.	–
F	Through mode	Not Used	Select this setting when using the terminal in a pass-through mode. The terminal does not trigger a drive function but can be used as digital input for the controller the drive is connected to.	–
10	Forward torque limit	Fwd Torque Limit	<b>OLV</b> 10 V = Motor rated torque	–
11	Reverse torque limit	Rev Torque Limit	<b>OLV</b> 10 V = Motor rated torque	–



H3 Multi-Function Analog Input Settings				
H3-□□ Setting	Function	LCD Display	Description	Page
12	Regenerative torque limit	Regen Torq Limit	<b>OLV</b> 10 V = Motor rated torque	–
15	General torque limit	Torque Limit	<b>OLV</b> 10 V = Motor rated torque	–
16	Differential PID feedback	PID Feedback 2	10 V = 100%	–
1F	Through mode	Not Used	Set this value when using the terminal in the pass-through mode.	–
20	HAND Frequency Reference	Hand Freq. Ref.	Full scale: Max. frequency (E1-04)	–
21	Geothermal Temperature	Geothermal Temp	Full scale: Q2-02 = 10 V (or 20 mA), Q2-01 = 0 V (or 4 mA) This input is internally limited to -110.0 °F to +320.0 °F after gain and bias.	–
22	Flow Meter	Flow Meter	Full scale: P6-01	–
23	Water Level or Suction Input	WaterLvl/Suction	When Water Level Control is enabled (Q4-01 = 1): 0 V or 4 mA = 0 (ft) 10 V or 20 mA = Q4-02 (PSI) * 2.308 ft/PSI OR When Suction Pressure Control is enabled (Q5-01 = 1) <2> 0 V or 4 mA = 9 (PSI) 10 V or 20 mA = Q5-02 (PSI) OR When Vacuum Control is enabled (Q5-01 = 2) <3> 0 V or 4 mA = 0 (”Hg) 10 V or 20 mA = Q5-02 (”Hg)	–
24 <1>	PI Feedback Backup	PI FdBack Backup	Full scale: FB Device Scaling (P1-03)	–
25	Secondary PI Setpoint	PI2 Setpoint	10 V = S3-02 (maximum output frequency)	–
26	Secondary PI Feedback	PI2 Feedback	10 V = S3-02 (maximum output frequency)	–
27 <4>	PI Auxiliary Feedback Level	PI Aux FB Level	0 V or 4 mA = 0 (unit based on Q6-22) 10 V or 20 mA = Q6-02 (unit based on Q6-22)	–
28 <4>	Differential PI Feedback	Diff PI Feedback	Full scale: FB Device Scaling (P1-03)	–

<1> Available in drive software versions PRG: 8551 and later.

<2> When Pressure Control is enabled (Q5-01 = 1), the action of the analog input is normal. A higher voltage or current on the input causes a higher pressure to be read in the drive.

<3> When Vacuum Control is enabled (Q5-01 = 2), the action of the analog input is reversed. A higher voltage or current on the input causes a lower pressure (or higher level of vacuum) to be read in the drive.

<4> Available in drive software versions PRG: 8552 and later. Not available in drive models 4A0930 and 4A1200.

### ◆ H4: Analog Outputs

No. (Addr. Hex)	Name	LCD Display	Description	Values	Page
H4-01 (041D)	Multi-Function Analog Output Terminal FM Monitor Selection	Term FM FuncSel	Selects the data to be output through multi-function analog output terminal FM. Set the desired monitor parameter to the digits available in U□-□□. For example, enter “103” for U1-03.	Default: 102 Range: 000 to 999	227
H4-02 (041E) [RUN]	Multi-Function Analog Output Terminal FM Gain	Terminal FM Gain	Sets the signal level at terminal FM that is equal to 100% of the selected monitor value.	Default: 100.0% Min.: -999.9 Max.: 999.9	228
H4-03 (041F) [RUN]	Multi-Function Analog Output Terminal FM Bias	Terminal FM Bias	Sets the signal level at terminal FM that is equal to 0% of the selected monitor value.	Default: 0.0% Min.: -999.9 Max.: 999.9	228
H4-04 (0420)	Multi-Function Analog Output Terminal AM Monitor Selection	Terminal AM Sel	Selects the data to be output through multi-function analog output terminal AM. Set the desired monitor parameter to the digits available in U□-□□. For example, enter “103” for U1-03.	Default: 103 Range: 000 to 999	227

## B.8 H Parameters: Multi-Function Terminals

No. (Addr. Hex)	Name	LCD Display	Description	Values	Page
H4-05 (0421) [RUN]	Multi-Function Analog Output Terminal AM Gain	Terminal AM Gain	Sets the signal level at terminal AM that is equal to 100% of the selected monitor value.	Default: 50.0% Min.: -999.9 Max.: 999.9	228
H4-06 (0422) [RUN]	Multi-Function Analog Output Terminal AM Bias	Terminal AM Bias	Sets the signal level at terminal AM that is equal to 0% of the selected monitor value.	Default: 0.0% Min.: -999.9 Max.: 999.9	228
H4-07 (0423)	Multi-Function Analog Output Terminal FM Signal Level Selection	Level Select1 0: 0-10 VDC 1: -10 +10 VDC 2: 4-20 mA	0: 0 to 10 V 1: -10 to 10 V 2: 4 to 20 mA	Default: 0 Range: 0 to 2	229
H4-08 (0424)	Multi-Function Analog Output Terminal AM Signal Level Selection	AO Level Select2 0: 0-10 VDC 1: -10 +10 VDC 2: 4-20 mA	0: 0 to 10 V 1: -10 to 10 V 2: 4 to 20 mA	Default: 0 Range: 0 to 2	229

## ◆ H5: MEMOBUS/Modbus Serial Communication

No. (Addr. Hex)	Name	LCD Display	Description	Values	Page
H5-01 (0425) </>	Drive Node Address	Serial Comm Adr	Selects drive station node number (address) for MEMOBUS/Modbus terminals R+, R-, S+, S-. Cycle power for the setting to take effect.	Default: 1F (Hex) Min.: 0 Max.: FF <2>	455
H5-02 (0426)	Communication Speed Selection	Serial Baud Rate 0: 1200 bps 1: 2400 bps 2: 4800 bps 3: 9600 bps 4: 19.2 kbps 5: 38.4 kbps 6: 57.6 kbps 7: 76.8 kbps 8: 115.2 kbps	0: 1200 bps 1: 2400 bps 2: 4800 bps 3: 9600 bps 4: 19200 bps 5: 38400 bps 6: 57600 bps 7: 76800 bps 8: 115200 bps Cycle power for the setting to take effect.	Default: 3 Range: 0 to 8	455
H5-03 (0427)	Communication Parity Selection	Serial Com Sel 0: No parity 1: Even parity 2: Odd parity	0: No parity 1: Even parity 2: Odd parity Cycle power for the setting to take effect.	Default: 0 Range: 0 to 2	455
H5-04 (0428)	Stopping Method after Communication Error (CE)	Serial Fault Sel 0: Ramp to Stop 1: Coast to Stop 2: Fast-Stop 3: Alarm Only 4: Run at H5-14 <3>	0: Ramp to stop 1: Coast to stop 2: Fast Stop 3: Alarm only 4: Run at H5-14 <3>	Default: 3 Range: 0 to 4	455
H5-05 (0429)	Communication Fault Detection Selection	Serial Flt Dct 0: Disabled 1: Enabled	0: Disabled 1: Enabled. If communication is lost for more than two seconds, a CE fault will occur.	Default: 1 Range: 0, 1	456
H5-06 (042A)	Drive Transmit Wait Time	Transmit WaitTIM	Set the wait time between receiving and sending data.	Default: 5 ms Min.: 5 Max.: 65	456
H5-07 (042B)	RTS Control Selection	RTS Control Sel 0: Disabled 1: Enabled	0: Disabled. RTS is always on. 1: Enabled. RTS turns on only when sending.	Default: 1 Range: 0, 1	456
H5-09 (0435)	CE Detection Time	CE Detect Time	Sets the time required to detect a communications error. Adjustment may be needed when networking several drives.	Default: 2.0 s Min.: 0.0 Max.: 10.0	456
H5-10 (0436)	Unit Selection for MEMOBUS/Modbus Register 0025H	CommReg 25h Unit 0: 0.1 V 1: 1 V	0: 0.1 V units 1: 1 V units	Default: 0 Range: 0, 1	457
H5-11 (043C)	Communications ENTER Function Selection	Enter CommandSel 0: Enter Required 1: No EnterRequired	0: Drive requires an Enter command before accepting any changes to parameter settings. 1: Parameter changes are activated immediately without the Enter command.	Default: 0 Range: 0, 1	457

No. (Addr. Hex)	Name	LCD Display	Description	Values	Page
H5-12 (043D)	Run Command Method Selection	Run CommandSel 0: FWD Run &REV Run 1: Run & FWD/REV	0: FWD/Stop, REV/Stop 1: Run/Stop, FWD/REV	Default: 0 Range: 0, 1	457
H5-13 (043E) <3>	Power-up CALL Alarm	Powr-up CALL Alm 0: Disabled 1: Enabled	Determines whether a CALL alarm is triggered at power-up when communication with the external controller has not been established. 0: Disabled 1: Enabled	Default: 0 Range: 0, 1	-
H5-14 (0FB4) RUN <3>	Communication Error (CE) Go-To- Frequency	CE Go-To-Freq	Sets the speed at which the drive will run when H5-04 is set to 4 (Run at H5-14) and a CE error is present.	Default: 0.0 Hz Min.: 0.0 Max.: 400.0	457
H5-15 (0FB5) RUN <3>	Communication Error (CE) Go-To-Timeout	CE Go-To-Timeout	Sets the amount of time that the drive will run at the speed set in H5-14 before triggering a CE fault when H5-04 is set to 4 (Run at H5-14) and a CE error is present. Setting this parameter to 0 will disable the time-out.	Default: 0 s Min.: 0 Max.: 6000	457
H5-16 (0FB6) <3>	Communication Error Fault Restart Selection	CE Fault Restart 0: No Retry 1: Retry	Determines whether the CE fault can be restarted (L5-01). 0: No Retry 1: Retry	Default: 0 Range: 0, 1	457

<1> If this parameter is set to 0, the drive will be unable to respond to MEMOBUS/Modbus commands.

<2> When P1-01, Pump Mode, is set to 3 (MEMOBUS network), the range is dependent on P9-25, Highest Node Address.

<3> Available in drive software versions PRG: 8552 and later. Not available in drive models 4A0930 and 4A1200.

### ◆ H6: Pulse Train Input

No. (Addr. Hex)	Name	LCD Display	Description	Values	Page
H6-01 (042C)	Pulse Train Input Terminal RP Function Selection	Term RP Func Sel 0: Frequency Ref 1: PID Feedback 2: PID Set Point 5: Flow Meter	0: Frequency reference 1: PID feedback value 2: PID setpoint value 5: Flow meter  <b>Note:</b> When this parameter is set to 5, parameters H6-02 to H6-04 and H6-08 are ignored.	Default: 0 Range: 0 to 2; 5	-
H6-02 (042D) RUN	Pulse Train Input Scaling	Term RP Scaling	Sets the terminal RP input signal frequency that is equal to 100% of the value selected in H6-01.	Default: 1440 Hz Min.: 100 Max.: 32000	-
H6-03 (042E) RUN	Pulse Train Input Gain	Terminal RP Gain	Sets the level of the value selected in H6-01 when a frequency with the value set in H6-02 is input.	Default: 100.0% Min.: 0.0 Max.: 1000.0	-
H6-04 (042F) RUN	Pulse Train Input Bias	Terminal RP Bias	Sets the level of the value selected in H6-01 when 0 Hz is input.	Default: 0.0% Min.: -100.0 Max.: 100.0	-
H6-05 (0430) RUN	Pulse Train Input Filter Time	Term RP Flt Time	Sets the pulse train input filter time constant.	Default: 0.50 s Min.: 0.00 Max.: 2.00	-
H6-08 (043F)	Pulse Train Input Minimum Frequency	RP Lower Limit	Sets the minimum frequency for the pulse train input to be detected. Enabled when H6-01 = 0, 1, or 2.	Default: 0.5 Hz Min.: 0.1 Max.: 1000.0	-

## B.9 L: Protection Function

L parameters provide protection to the drive and motor, including control during momentary power loss, Stall Prevention, frequency detection, fault restarts, overtorque detection, and other types of hardware protection.

### ◆ L1: Motor Protection

No. (Addr. Hex)	Name	LCD Display	Description	Values	Page
L1-01 (0480)	Motor Overload Protection Selection	Mtr OL Charact 0: OL1 Disabled 1: VT Motor 2: CT Motor 3: Vector Motor 6: 50Hz VT Motor	0: Disabled 1: General purpose motor (standard fan cooled) 2: Drive dedicated motor with a speed range of 1:10 3: Vector motor with a speed range of 1:100 6: General purpose motor (50 Hz) The drive may not be able to provide protection when using multiple motors, even if overload is enabled in L1-01. Set L1-01 to 0 and install separate thermal relays to each motor.	Default: 1 Range: 0 to 3; 6	–
L1-02 (0481)	Motor Overload Protection Time	MOL Time Const	Sets the motor thermal overload protection (oL1) time.	Default: 1.0 min Min.: 0.1 Max.: 5.0	–
L1-03 (0482)	Motor Overheat Alarm Operation Selection (PTC input)	Mtr OH Alarm Sel 0 : Ramp to Stop 1: Coast to Stop 2: Fast-Stop 3: Alarm only	Sets operation when the motor temperature analog input (H3-02, H3-10, or H3-06 = E) exceeds the oH3 alarm level. 0: Ramp to stop 1: Coast to stop 2: Fast Stop (decelerate to stop using the deceleration time in C1-09) 3: Alarm only (“oH3” will flash)	Default: 3 Range: 0 to 3	–
L1-04 (0483)	Motor Overheat Fault Operation Selection (PTC input)	Mtr OH Fault Sel 0 : Ramp to Stop 1: Coast to Stop 2: Fast-Stop	Sets stopping method when the motor temperature analog input (H3-02, H3-10, or H3-06 = E) exceeds the oH4 fault level. 0: Ramp to stop 1: Coast to stop 2: Fast Stop (decelerate to stop using the deceleration time in C1-09)	Default: 1 Range: 0 to 2	–
L1-05 (0484)	Motor Temperature Input Filter Time (PTC input)	Mtr Temp Filter	Adjusts the filter for the motor temperature analog input (H3-02, H3-10, or H3-06 = E).	Default: 0.20 s Min.: 0.00 Max.: 10.00	–
L1-13 (046D)	Continuous Electrothermal Operation Selection	Mtr OL Mem Sel 0: Disabled 1: Enabled 2: Enabled(RTC)	0: Disabled 1: Enabled 2: Enabled (RTC)	Default: 2 <?> Range: 0 to 2	–
L1-15 (0440)	Motor 1 Thermistor Selection (NTC)	M1 OH5 Fault Sel	0: Disabled 1: Enabled <b>Note:</b> This parameter is only available in models 4A0930 and 4A1200.	Default: 0 Range: 0, 1	–
L1-16 (0441)	Motor 1 Overheat Temperature	M1 OH5 level	Sets the temperature for motor 1 that triggers an overheat fault (oH5). <b>Note:</b> This parameter is only available in models 4A0930 and 4A1200.	Default: 120 °C Min.: 50 Max.: 200	–
L1-17 (0442)	Motor 2 Thermistor Selection (NTC)	M2 OH5 Fault Sel	0: Disabled 1: Enabled <b>Note:</b> This parameter is only available in models 4A0930 and 4A1200.	Default: 0 Range: 0, 1	–
L1-18 (0443)	Motor 2 Overheat Temperature	M2 OH5 level	Sets the temperature for motor 1 that triggers an overheat fault (oH5). <b>Note:</b> This parameter is only available in models 4A0930 and 4A1200.	Default: 120 °C Min.: 50 Max.: 200	–

No. (Addr. Hex)	Name	LCD Display	Description	Values	Page
L1-19 (0444)	Operation at Thermistor Disconnect (THo) (NTC)	Tho Stop sel	Determines drive response when a thermistor disconnect fault (THo) occurs. 0: Ramp to stop 1: Coast to stop 2: Fast Stop (decelerate to stop using the deceleration time set to C1-09) 3: Alarm only (“THo” will flash)  <b>Note:</b> This parameter is only available in models 4A0930 and 4A1200.	Default: 3 Range: 0 to 3	–
L1-20 (0445)	Operation at Motor Overheat (oH5)	OH5 Stop sel	Determines drive response when a motor overheat fault (oH5) occurs. 0: Ramp to stop 1: Coast to stop 2: Fast Stop (decelerate to stop using the deceleration time set to C1-09) 3: Alarm only (“oH5” will flash)  <b>Note:</b> This parameter is only available in models 4A0930 and 4A1200.	Default: 1 Range: 0 to 3	–

<1> Default is 1 in drive software versions PRG: 8551 and earlier.

### ◆ L2: Momentary Power Loss Ride-Thru

No. (Addr. Hex)	Name	LCD Display	Description	Values	Page
L2-01 (0485)	Momentary Power Loss Operation Selection	PwrL Selection 0: Disabled 1: Enbl with Timer 2: Enbl whl CPU act 3: KEB Mode 4: KEB Stop Mode 5: KEB Decel to Stop	0: Disabled. Drive trips on Uv1 fault when power is lost. 1: Recover within the time set in L2-02. Uv1 will be detected if power loss is longer than L2-02. 2: Recover as long as CPU has power. Uv1 is not detected. 3: KEB deceleration for the time set to L2-02. 4: KEB deceleration as long as CPU has power. 5: KEB deceleration to stop.	Default: 2 Range: 0 to 5	–
L2-02 (0486)	Momentary Power Loss Ride-Thru Time	PwrL Ridethru t	Sets the Power Loss Ride-Thru time. Enabled only when L2-01 = 1 or 3.	Default: </> Min.: 0.0 s Max.: 25.5 s	–
L2-03 (0487)	Momentary Power Loss Minimum Baseblock Time	PwrL Baseblock t	Sets the minimum wait time for residual motor voltage decay before the drive output reenergizes after performing Power Loss Ride-Thru. Increasing the time set to L2-03 may help if overcurrent or overvoltage occur during Speed Search or during DC Injection Braking.	Default: </> Min.: 0.1 s Max.: 5.0 s	–
L2-04 (0488)	Momentary Power Loss Voltage Recovery Ramp Time	PwrL V/F Ramp t	Sets the time for the output voltage to return to the preset V/f pattern during Speed Search.	Default: </> Min.: 0.0 s Max.: 5.0 s	–
L2-05 (0489)	Undervoltage Detection Level (Uv1)	PUV Det Level	Sets the DC bus undervoltage trip level.	Default: 190 Vdc <2> <3> Min.: 150 Vdc Max.: 210 Vdc <2>	–
L2-06 (048A)	KEB Deceleration Time	KEB Decel Time	Sets the time required to decelerate from the speed when KEB was activated to zero speed.	Default: 0.00 s Min.: 0.00 Max.: 6000.0 <2>	–
L2-07 (048B)	KEB Acceleration Time	KEB Accel Time	Sets the time to accelerate to the frequency reference when momentary power loss is over. If set to 0.0, the active acceleration time is used.	Default: 0.00 s Min.: 0.00 Max.: 6000.0 <2>	–
L2-08 (048C)	Frequency Gain at KEB Start	KEB Freq Red	Sets the percentage of output frequency reduction at the beginning of deceleration when the KEB Ride-Thru function is started. Reduction = (slip frequency before KEB) × L2-08 × 2	Default: 100% Min.: 0 Max.: 300	–

Parameter List

**B**

## B.9 L: Protection Function

No. (Addr. Hex)	Name	LCD Display	Description	Values	Page
L2-10 (048E)	KEB Detection Time (Minimum KEB Time)	KEB Detect Time	Sets the time to perform KEB Ride-Thru.	Default: 50 ms Min.: 0 Max.: 2000	–
L2-11 (0461)	DC Bus Voltage Setpoint during KEB	KEB DC Bus Level	Sets the desired value of the DC bus voltage during KEB Ride-Thru.	Default: <2> [E1-01] × 1.22 Min.: 150 Vdc Max.: 400 Vdc <5>	–
L2-29 (0475)	KEB Method Selection	KEB Mode Sel 0: Single Mode KEB1 1: Single Mode KEB2 2: System Mode KEB1 3: System Mode KEB2	0: Single Drive KEB Ride-Thru 1 1: Single Drive KEB Ride-Thru 2 2: System KEB Ride-Thru 1 3: System KEB Ride-Thru 2	Default: 0 Range: 0 to 3	–

<1> Default setting is dependent on parameter o2-04, Drive Model Selection.

<2> Default setting is dependent on parameter E1-01, Input voltage Setting.

<3> Values shown are specific to 200 V class drives. Double the value for 400 V class drives. Multiply the value by 2.875 for 600 V class drives.

<4> Setting range value is dependent on parameter C1-10, Accel/Decel Time Setting Units. When C1-10 = 0 (units of 0.01 seconds), the setting range becomes 0.00 to 600.00 seconds.

<5> Values shown are specific to 200 V class drives. Double the value for 400 V class drives. Multiply the value by 2.875 for 600 V class drives, but set the value below 1040 Vdc (overvoltage protection level).

## ◆ L3: Stall Prevention

No. (Addr. Hex)	Name	LCD Display	Description	Values	Page
L3-01 (048F)	Stall Prevention Selection during Acceleration	StallP Accel Sel 0: Disabled 1: General Purpose 2: Intelligent	0: Disabled. 1: General purpose. Acceleration is paused as long as the current is above the L3-02 setting. 2: Intelligent. Accelerate in the shortest possible time without exceeding the L3-02 level.	Default: 1 Range: 0 to 2	–
L3-02 (0490)	Stall Prevention Level during Acceleration	StallP Accel Lvl	Used when L3-01 = 1 or 2. 100% is equal to the drive rated current.	Default: <1> Min.: 0% Max.: 150% <1>	–
L3-03 (0491)	Stall Prevention Limit during Acceleration	StallPAcc LowLim	Sets Stall Prevention lower limit during acceleration when operating in the constant power range. Set as a percentage of drive rated current.	Default: 50% Min.: 0 Max.: 100	–
L3-04 (0492)	Stall Prevention Selection during Deceleration	StallP Decel Sel 0: Disabled 1: General Purpose 2: Intelligent 3: StallP +Resistor 4: High Flux Brake 5: High Flux Brake2	0: Disabled. Deceleration at the active deceleration rate. An ov fault may occur. 1: General purpose. Deceleration is paused when the DC bus voltage exceeds the Stall Prevention level. 2: Intelligent. Decelerate as fast as possible while avoiding ov faults. 3: Stall Prevention with braking resistor. Stall Prevention during deceleration is enabled in coordination with dynamic braking. 4: Overexcitation Deceleration. Decelerates while increasing the motor flux. 5: Overexcitation Deceleration 2. Adjust the deceleration rate according to the DC bus voltage.  <b>Note:</b> Setting 3 is not available in models 4A0930 and 4A1200.	Default: 0 Range: 0 to 5	–
L3-05 (0493)	Stall Prevention Selection during Run	StallP Run Sel 0: Disabled 1: Decel Time 2: Decel Time 2	0: Disabled. Drive runs at a set frequency. A heavy load may cause speed loss. 1: Decel time 1. Uses the deceleration time set to C1-02 while Stall Prevention is performed. 2: Decel time 2. Uses the deceleration time set to C1-04 while Stall Prevention is performed.	Default: 0 Range: 0 to 2	–
L3-06 (0494)	Stall Prevention Level during Run	StallP Run Level	<b>V/f</b> Enabled when L3-05 is set to 1 or 2. 100% is equal to the drive rated current.	Default: <1> Min.: 30% Max.: 150% <1>	–

No. (Addr. Hex)	Name	LCD Display	Description	Values	Page
L3-11 (04C7)	Overvoltage Suppression Function Selection	OV Inhibit Sel 0: Disabled 1: Enabled	Enables or disables the ov suppression function, which allows the drive to change the output frequency as the load changes to prevent an ov fault. 0: Disabled 1: Enabled	Default: 0 Range: 0, 1	–
L3-17 (0462)	Target DC Bus Voltage for Overvoltage Suppression and Stall Prevention	DC Bus Reg Level	Sets the desired value for the DC bus voltage during overvoltage suppression and Stall Prevention during deceleration.	Default: 375 Vdc <2> <3> Min.: 150 Max.: 400 <3>	–
L3-20 (0465)	DC Bus Voltage Adjustment Gain	DC Bus P Gain	Sets the proportional gain for KEB Ride-Thru, Stall Prevention, and overvoltage suppression.	Default: 1.00 (V/f) 0.30 (OLV) Min.: 0.00 Max.: 5.00	–
L3-21 (0466)	Accel/Decel Rate Calculation Gain	Acc/Dec P Gain	Sets the proportional gain used to calculate the deceleration rate during KEB Ride-Thru, ov suppression function, and Stall Prevention during deceleration (L3-04 = 2).	Default: 1.00 Min.: 0.10 Max.: 10.00	–
L3-23 (04FD)	Automatic Reduction Selection for Stall Prevention during Run	CHP Stall P Sel 0: Lv1 set in L3-06 1: Autom. Reduction	<b>V/f</b> 0: Sets the Stall Prevention level set in L3-06 that is used throughout the entire frequency range. 1: Automatic Stall Prevention level reduction in the constant output range. The lower limit value is 40% of L3-06.	Default: 0 Range: 0, 1	–
L3-24 (046E)	Motor Acceleration Time for Inertia Calculations	Mtr Accel Time	Sets the time needed to accelerate the uncoupled motor at rated torque from stop to the maximum frequency.	Default: <4> <5> Min.: 0.001 s Max.: 10.000 s	–
L3-25 (046F)	Load Inertia Ratio	Load Inertia Rat	Sets the ratio between the motor and machine inertia.	Default: 1.0 Min.: 1.0 Max.: 1000.0	–
L3-26 (0455)	Additional DC Bus Capacitors	ExtDC busCapSize	When DC bus capacitors have been added externally, be sure to add those values to the internal capacitor table for proper DC bus calculations.	Default: 0 μF Min.: 0 Max.: 65000	–
L3-27 (0456)	Stall Prevention Detection Time	Stl Prev DetTime	Sets the time the current must exceed the Stall Prevention level to activate Stall Prevention.	Default: 50 ms Min.: 0 Max.: 5000	–
L3-35 (0747)	Speed Agree Width at Intelligent Stall Prevention during Deceleration	IntDecSpdAgrWdth	Sets the width of the speed agree when L3-04 = 2 (Intelligent Stall Prevention during deceleration) in units of 0.01 Hz. There is normally no need to change this parameter from the default value. <b>Note:</b> This parameter is not available in models 4A0930 and 4A1200.	Default: 0.00 Hz Min.: 0.00 Max.: 1.00	–

<1> Upper limit is dependent on parameter L8-38, Frequency Reduction Selection.

<2> Default setting is dependent on parameter E1-01, Input voltage Setting.

<3> Values shown are specific to 200 V class drives. Double the value for 400 V class drives. Multiply the value by 2.875 for 600 V class drives, but set the value below 1040 Vdc (overvoltage protection level).

<4> Parameter value changes automatically if E2-11 is manually changed or changed by Auto-Tuning.

<5> Default setting is dependent on parameter o2-04, Drive Model Selection.

### ◆ L4: Speed Detection

No. (Addr. Hex)	Name	LCD Display	Description	Values	Page
L4-01 (0499)	Speed Agreement Detection Level	Spd Agree Level	L4-01 sets the frequency detection level for digital output functions H2-□□ = 2, 3, 4, 5.	Default: 0.0 Hz Min.: 0.0 Max.: 400.0	–
L4-02 (049A)	Speed Agreement Detection Width	Spd Agree Width	L4-02 sets the hysteresis or allowable margin for speed detection.	Default: 2.0 Min.: 0.0 Max.: 20.0	–
L4-03 (049B)	Speed Agreement Detection Level (+/-)	Spd Agree Lvl+-	L4-03 sets the frequency detection level for digital output functions H2-□□ = 13, 14, 15, 16.	Default: 0.0 Hz Min.: -400.0 Max.: 400.0	–

## B.9 L: Protection Function

No. (Addr. Hex)	Name	LCD Display	Description	Values	Page
L4-04 (049C)	Speed Agreement Detection Width (+/-)	Spd Agree Wdth+-	L4-04 sets the hysteresis or allowable margin for speed detection.	Default: 2.0 Min.: 0.0 Max.: 20.0	-
L4-05 (049D)	Frequency Reference Loss Detection Selection	Ref Loss Sel 0: Stop 1: Run@L4-06PrevRef	0: Stop. Drive stops when the frequency reference is lost. 1: Run. Drive runs at a reduced speed when the frequency reference is lost.	Default: 0 Range: 0, 1	-
L4-06 (04C2)	Frequency Reference at Reference Loss	Fref at Floss	Sets the percentage of the frequency reference that the drive should run with when the frequency reference is lost.	Default: 80.0% Min.: 0.0 Max.: 100.0	-
L4-07 (0470)	Speed Agreement Detection Selection	Freq Detect Sel 0: No Detection @BB 1: Always Detected	0: No detection during baseblock. 1: Detection always enabled.	Default: 0 Range: 0, 1	-

## ◆ L5: Fault Restart

No. (Addr. Hex)	Name	LCD Display	Description	Values	Page
L5-01 (049E)	Number of Auto Restart Attempts	Num of Restarts	Sets the number of times the drive may attempt to restart after the following faults occur: GF, LF, oC, ov, PF, rH, rr, oL1, oL2, oL3, oL4, STo, Uv1.	Default: 5 Min.: 0 Max.: 10	-
L5-02 (049F)	Auto Restart Fault Output Operation Selection	Restart Sel 0: Flt Outp Disabl 1: Flt Outp Enabled	0: Fault output not active. 1: Fault output active during restart attempt.	Default: 0 Range: 0, 1	-
L5-04 (046C)	Fault Reset Interval Time	Flt Reset Wait T	Sets the amount of time to wait between performing fault restarts.	Default: 20.0 s Min.: 10.0 Max.: 3600.0	-
L5-40 (0670)	Low Feedback Fault Retry Selection	Low Feedback 0: No retry 1: Retry	Determines whether the LFB-Low Feedback fault can be auto-restarted. 0: No retry 1: Retry	Default: 0 Range: 0, 1	-
L5-41 (0671)	High Feedback Fault Retry Selection	High Feedback 0: No retry 1: Retry	Determines whether the HFB-High Feedback fault can be auto-restarted. 0: No retry 1: Retry	Default: 0 Range: 0, 1	-
L5-42 (0672)	Feedback Loss Fault Retry Selection	Feedback Loss 0: No retry 1: Retry	Determines whether the FDBKL-Wire Break fault can be auto-restarted. 0: No retry 1: Retry	Default: 0 Range: 0, 1	-
L5-50 (067A)	Setpoint Not Met Retry Selection	SetPoint Not Met 0: No retry 1: Retry	Determines whether the NMS-Setpoint not Met fault can be auto-restarted. 0: No retry 1: Retry	Default: 0 Range: 0, 1	-
L5-51 (067B)	Loss of Prime Fault Retry Selection	Loss of Prime 0: No retry 1: Retry	Determines whether the LOP-Loss of Prime fault can be auto-restarted. 0: No retry 1: Retry	Default: 0 Range: 0, 1	-
L5-52 (067C)	Pump Over Cycle Fault Retry Selection	Pump Over Cycle 0: No retry 1: Retry	Determines whether the POC-Pump Over Cycle fault can be auto-restarted. 0: No retry 1: Retry	Default: 0 Range: 0, 1	-
L5-53 (067D)	Volute-TStat Retry Selection	Volute-TStat Flt 0: No retry 1: Retry	Determines whether the Volute T-Stat fault can be auto-restarted. 0: No retry 1: Retry  <b>Note:</b> The drive will restart only after the Volute-Tstat digital input deactivates and the L5-04 timer expires.	Default: 0 Range: 0, 1	-



◆ L6: Torque Detection

No. (Addr. Hex)	Name	LCD Display	Description	Values	Page
L6-01 (04A1)	Torque Detection Selection 1	Torq Det 1 Sel 0: Disabled 1: OL Alm at SpdAgr 2: OL Alm dur RUN 3: OL Flt at SpdAgr 4: OL Flt dur RUN 5: UL Alm at SpdAgr 6: UL Alm dur RUN 7: UL Flt at SpdAgr 8: UL Flt dur RUN 9: UL6Alm at SpdAgr 10: UL6Alm dur RUN 11: UL6Flt at SpdAgr 12: UL6Flt dur RUN	0: Disabled 1: oL3 detection only active during speed agree, operation continues after detection 2: oL3 detection always active during run, operation continues after detection 3: oL3 detection only active during speed agree, output shuts down on an oL3 fault 4: oL3 detection always active during run, output shuts down on an oL3 fault 5: UL3 detection only active during speed agree, operation continues after detection 6: UL3 detection always active during run, operation continues after detection 7: UL3 detection only active during speed agree, output shuts down on an oL3 fault 8: UL3 detection always active during run, output shuts down on an oL3 fault 9: UL6 Alarm at Speed Agree 10: UL6 Alarm during Run 11: UL6 Fault at Speed Agree 12: UL6 Fault during Run	Default: 0 Range: 0 to 12	–
L6-02 (04A2)	Torque Detection Level 1	Torq Det 1 Lvl	Sets the overtorque and undertorque detection level.	Default: 15% Min.: 0 Max.: 300	–
L6-03 (04A3)	Torque Detection Time 1	Torq Det 1 Time	Sets the time an overtorque or undertorque condition must exist to trigger torque detection 1.	Default: 10.0 s Min.: 0.0 Max.: 10.0	–
L6-04 (04A4)	Torque Detection Selection 2	Torq Det 2 Sel 0: Disabled 1: OL Alm at SpdAgr 2: OL Alm dur RUN 3: OL Flt at SpdAgr 4: OL Flt dur RUN 5: UL Alm at SpdAgr 6: UL Alm dur RUN 7: UL Flt at SpdAgr 8: UL Flt dur RUN	0: Disabled 1: oL4 detection only active during speed agree, operation continues after detection 2: oL4 detection always active during run, operation continues after detection 3: oL4 detection only active during speed agree, output shuts down on an oL4 fault 4: oL4 detection always active during run, output shuts down on an oL4 fault 5: UL4 detection only active during speed agree, operation continues after detection 6: UL4 detection always active during run, operation continues after detection 7: UL4 detection only active during speed agree, output shuts down on an oL4 fault 8: UL4 detection always active during run, output shuts down on an oL4 fault	Default: 0 Range: 0 to 8	–
L6-05 (04A5)	Torque Detection Level 2	Torq Det 2 Lvl	Sets the overtorque and undertorque detection level.	Default: 150% Min.: 0 Max.: 300	–
L6-06 (04A6)	Torque Detection Time 2	Torq Det 2 Time	Sets the time an overtorque or undertorque condition must exist to trigger torque detection 2.	Default: 0.1 s Min.: 0.0 Max.: 10.0	–
L6-13 (062E)	Motor Underload Protection Selection	Underload Select 0: Base Freq Enable 1: Max Freq Enable	Sets the motor underload protection (UL6) based on motor load. 0: Base frequency enable 1: Max frequency enable	Default: 0 Range: 0, 1	–
L6-14 (062F)	Motor Underload Protection Level at Minimum Frequency	Underload Level	Sets the UL6 detection level at minimum frequency by percentage of drive rated current.	Default: 15% Min.: 0 Max.: 300	–

## B.9 L: Protection Function

### ◆ L7: Torque Limit

No. (Addr. Hex)	Name	LCD Display	Description	Values	Page
L7-01 (04A7)	Forward Torque Limit	Torq Limit Fwd	<p><b>OLV</b></p> <p>Sets the torque limit value as a percentage of the motor rated torque. Four individual quadrants can be set.</p>	Default: 200% Min.: 0 Max.: 300	–
L7-02 (04A8)	Reverse Torque Limit	Torq Limit Rev		Default: 200% Min.: 0 Max.: 300	–
L7-03 (04A9)	Forward Regenerative Torque Limit	Torq Lmt Fwd Rgn		Default: 200% Min.: 0 Max.: 300	–
L7-04 (04AA)	Reverse Regenerative Torque Limit	Torq Lmt Rev Rgn		Default: 200% Min.: 0 Max.: 300	–
L7-06 (04AC)	Torque Limit Integral Time Constant	Trq Lim I Time	<p><b>OLV</b></p> <p>Sets the integral time constant for the torque limit.</p>	Default: 200 ms Min.: 5 Max.: 10000	–
L7-07 (04C9)	Torque Limit Control Method Selection during Accel/Decel	Trq Lim d AccDec 0: P-ctrl @ Acc/Dec 1: I-ctrl @ Acc/Dec	<p><b>OLV</b></p> <p>0: Proportional control (changes to integral control at constant speed). Use this setting when acceleration to the desired speed should take precedence over the torque limit. 1: Integral control. Set L7-07 to 1 if the torque limit should take precedence.</p>	Default: 0 Range: 0, 1	–
L7-16 (044D)	Torque Limit Process at Start	TLim DlyTime Sel 0: Disabled 1: Enabled	<p><b>OLV</b></p> <p>0: Disabled 1: Enabled</p>	Default: 1 Range: 0, 1	–

### ◆ L8: Drive Protection

No. (Addr. Hex)	Name	LCD Display	Description	Values	Page
L8-01 (04AD)	Internal Dynamic Braking Resistor Protection Selection (ERF type)	DB Resistor Prot 0: Not Provided 1: Provided	<p>0: Resistor overheat protection disabled 1: Resistor overheat protection enabled</p> <p><b>Note:</b> This parameter is not available in models 4A0930 and 4A1200.</p>	Default: 0 Range: 0, 1	–
L8-02 (04AE)	Overheat Alarm Level	OH Pre-Alarm Lvl	An overheat alarm occurs when heatsink temperature exceeds the L8-02 level.	Default: </> Min.: 50 °C Max.: 150 °C	–
L8-03 (04AF)	Overheat Pre-Alarm Operation Selection	OH Pre-Alarm Sel 0: Ramp to Stop 1: Coast to Stop 2: Fast-Stop 3: Alarm Only 4: Run@L8-19 Rate	<p>0: Ramp to stop. A fault is triggered. 1: Coast to stop. A fault is triggered. 2: Fast Stop. Decelerate to stop using the deceleration time in C1-09. A fault is triggered. 3: Continue operation. An alarm is triggered. 4: Continue operation at reduced speed as set in L8-19.</p>	Default: 3 Range: 0 to 4	–
L8-05 (04B1)	Input Phase Loss Protection Selection	Inp Ph Loss Det 0: Disabled 1: Enabled	<p>Selects the detection of input current phase loss, power supply voltage imbalance, or main circuit electrolytic capacitor deterioration.</p> <p>0: Disabled 1: Enabled</p>	Default: 1 Range: 0, 1	–
L8-07 (04B3)	Output Phase Loss Protection Selection	Outp Ph Loss Det 0: Disabled 1: 1PH Loss Det 2: 2/3PH Loss Det	<p>0: Disabled 1: Enabled (triggered by a single phase loss) 2: Enabled (triggered when two phases are lost)</p>	Default: 1 Range: 0 to 2	–
L8-09 (04B5)	Output Ground Fault Detection Selection	Grnd Flt Det Sel 0: Disabled 1: Enabled	<p>0: Disabled 1: Enabled</p>	Default: 1 Range: 0, 1	–
L8-10 (04B6)	Heatsink Cooling Fan Operation Selection	Fan On/Off Sel 0: Dur Run (OffDly) 1: Always On	<p>0: During run only. Fan operates only during run for L8-11 seconds after stop. 1: Fan always on. Cooling fan operates whenever the drive is powered up.</p>	Default: 0 Range: 0, 1	–

No. (Addr. Hex)	Name	LCD Display	Description	Values	Page
L8-11 (04B7)	Heatsink Cooling Fan Off Delay Time	Fan Delay Time	Sets a delay time to shut off the cooling fan after the Run command is removed when L8-10 = 0.	Default: 300 s Min.: 0 Max.: 300	–
L8-12 (04B8)	Ambient Temperature Setting	Ambient Temp	Enter the ambient temperature. This value adjusts the oL2 detection level.	Default: 40 °C Min.: -10 Max.: 50	–
L8-15 (04BB)	oL2 Characteristics Selection at Low Speeds	OL2 Sel @ L-Spd 0: Disabled 1: Enabled	0: No oL2 level reduction below 6 Hz. 1: oL2 level is reduced linearly below 6 Hz. It is halved at 0 Hz.	Default: 1 Range: 0, 1	–
L8-18 (04BE)	Software Current Limit Selection	Soft CLA Sel 0: Disabled 1: Enabled	0: Disabled 1: Enabled	Default: 0 Range: 0, 1	–
L8-19 (04BF)	Frequency Reduction Rate during Overheat Pre-Alarm	Fc Red dur OHAIm	Specifies the frequency reference reduction gain at overheat pre-alarm when L8-03 = 4.	Default: 0.8 Min.: 0.1 Max.: 0.9	–
L8-32 (04E2)	Main Contactor and Cooling Fan Power Supply Failure Selection	MC, Fan Fault Sel 0: Ramp to Stop 1: Coast to Stop 2: Fast-Stop 3: Alarm Only 4: Run@L8-19 Rate	Determines drive response when a fault occurs with the internal cooling fan. 0: Ramp to stop 1: Coast to stop 2: Fast stop (Decelerate to stop using the deceleration time set to C1-09) 3: Alarm only (“FAn” will flash) 4: Continue operation at reduced speed as set to L8-19.	Default: 1 Range: 0 to 4	–
L8-35 (04EC)	Installation Method Selection	Installation Sel 0: IP00/OpenChassis 1: Side-by-Side 2: IP20/Nema Type 1 3: Finless/Fin Ext	0: IP00/Open-Chassis enclosure 1: Side-by-Side mounting 2: IP20/NEMA 1, UL Type 1 enclosure 3: Finless model drive or external heatsink installation	Default: <2> <3> Range: 0 to 3	–
L8-38 (04EF)	Carrier Frequency Reduction	Fc Reduct dur OL 0: Disabled 1: Active below 6Hz 2: Active @ any Spd	0: Disabled 1: Enabled below 6 Hz 2: Enabled for the entire speed range	Default: 2 Range: 0 to 2	–
L8-40 (04F1)	Carrier Frequency Reduction Off Delay Time	Fc Reduct Time	Sets the time that the drive continues running with reduced carrier frequency after the carrier reduction condition is gone. Setting 0.00 s disables the carrier frequency reduction time.	Default: 0.5 s Min.: 0.00 Max.: 2.00	–
L8-41 (04F2)	High Current Alarm Selection	High Cur Alm Sel 0: Disabled 1: Enabled	0: Disabled 1: Enabled. An alarm is triggered at output currents above 150% of drive rated current.	Default: 0 Range: 0, 1	–
L8-55 (045F)	Internal Braking Transistor Protection	DB Tr protetion 0: Disable 1: Enable	0: Disabled. Disable when using a regen converter or optional braking unit. 1: Protection enabled. <b>Note:</b> This parameter is not available in models 4A0930 and 4A1200.	Default: 1 Range: 0, 1	–

- <1> Default setting is dependent on parameter o2-04, Drive Model Selection.
- <2> Parameter setting value is not reset to the default value when the drive is initialized.
- <3> Default setting is determined by the drive model:  
 Setting 2: Model code 2A0004 to 2A0211, 4A0002 to 4A0165, and 5A0003 to 5A0242  
 Setting 0: Model code 2A0250 to 2A0415 and 4A0208 to 4A1200.

## B.10 n: Special Adjustment

The n parameters adjust more advanced performance characteristics such as Hunting Prevention, High Slip Braking, and Overexcitation Braking.

### ◆ n1: Hunting Prevention

No. (Addr. Hex)	Name	LCD Display	Description	Values	Page
n1-01 (0580)	Hunting Prevention Selection	Hunt Prev Select 0: Disabled 1: Enabled	<b>V/f</b> 0: Disabled 1: Enabled	Default: 1 Range: 0, 1	–
n1-02 (0581)	Hunting Prevention Gain Setting	Hunt Prev Gain	<b>V/f</b> If the motor vibrates while lightly loaded, increase the gain by 0.1 until vibration ceases. If the motor stalls, decrease the gain by 0.1 until the stalling ceases.	Default: 1.00 Min.: 0.00 Max.: 2.50	–
n1-03 (0582)	Hunting Prevention Time Constant	Hunt Prev Time	<b>V/f</b> Sets the time constant used for Hunting Prevention.	Default: </> Min.: 0 ms Max.: 500 ms	–
n1-05 (0530)	Hunting Prevention Gain while in Reverse	Hprev Gain @Rev	<b>V/f</b> Sets the gain used for Hunting Prevention. If set to 0, the gain set to n1-02 is used for operation in reverse.	Default: 0.00 Min.: 0.00 Max.: 2.50	–

<1> Default setting is dependent on parameter o2-04, Drive Model Selection.

### ◆ n2: Speed Feedback Detection Control (AFR) Tuning

No. (Addr. Hex)	Name	LCD Display	Description	Values	Page
n2-01 (0584)	Speed Feedback Detection Control (AFR) Gain	AFR Gain	<b>OLV</b> Sets the internal speed feedback detection control gain in the automatic frequency regulator (AFR). If hunting occurs, increase the set value. If response is low, decrease the set value.	Default: 1.00 Min.: 0.00 Max.: 10.00	–
n2-02 (0585)	Speed Feedback Detection Control (AFR) Time Constant 1	AFR Time	<b>OLV</b> Sets the time constant used for speed feedback detection control (AFR).	Default: 50 ms Min.: 0 Max.: 2000	–
n2-03 (0586)	Speed Feedback Detection Control (AFR) Time Constant 2	AFR Time 2	<b>OLV</b> Sets the AFR time constant to be used during Speed Search and during regen.	Default: 750 ms Min.: 0 Max.: 2000	–

### ◆ n3: High Slip Braking (HSB) and Overexcitation Braking

No. (Addr. Hex)	Name	LCD Display	Description	Values	Page
n3-01 (0588)	High-Slip Braking Deceleration Frequency Width	HSB DecStepWidth	<b>V/f</b> Sets the output frequency reduction step width for when the drive stops the motor using HSB. Set as a percentage of the maximum output frequency. Increase this setting if overvoltage occurs during HSB.	Default: 5% Min.: 1 Max.: 20	–
n3-02 (0589)	High-Slip Braking Current Limit	HSB Current Lim	<b>V/f</b> Sets the current limit during HSB as a percentage of the motor rated current.	Default: </> Min.: 0% Max.: 200%	–
n3-03 (058A)	High-Slip Braking Dwell Time at Stop	HSB DwellTim@Stp	<b>V/f</b> Sets the time the drive will run with minimum frequency (E1-09) at the end of deceleration. If this time is set too low, the machine inertia can cause the motor to rotate slightly after HSB.	Default: 1.0 s Min.: 0.0 Max.: 10.0	–

No. (Addr. Hex)	Name	LCD Display	Description	Values	Page
n3-04 (058B)	High-Slip Braking Overload Time	HSB OL Time	<b>V/f</b> Sets the time required for an HSB overload fault (oL7) to occur when the drive output frequency does not change during an HSB stop. This parameter does not typically require adjustment.	Default: 40 s Min.: 30 Max.: 1200	–
n3-13 (0531)	Overexcitation Deceleration Gain	Hflux Brake Gain	Sets the gain applied to the V/f pattern during Overexcitation Deceleration (L3-04 = 4).	Default: 1.10 Min.: 1.00 Max.: 1.40	–
n3-14 (0532)	High Frequency Injection during Overexcitation Deceleration	HarmInj@HiFlxBrk 0: Disabled 1: Enabled	Enables High Frequency Injection while Overexcitation Deceleration is executed. 0: Disabled 1: Enabled	Default: 0 Range: 0, 1	–
n3-21 (0579)	High-Slip Suppression Current Level	Hflux I Supp Lvl	Sets output current level at which the drive will start reducing the overexcitation gain in order to prevent a too high motor slip during Overexcitation Deceleration. Set as a percentage of the drive rated current.	Default: 100% Min.: 0 Max.: 150	–
n3-23 (057B)	Overexcitation Operation Selection	Hflux Brake Sel 0: Enabled-Both Dir 1: Enabled-Fwd only 2: Enabled-Rev only	0: Enabled in both directions 1: Enabled only when rotating forward 2: Enabled only when in reverse	Default: 0 Range: 0 to 2	–

<1> Default setting is dependent on parameter L8-38, Frequency Reduction Selection.

### ◆ n6: Online Tuning

No. (Addr. Hex)	Name	LCD Display	Description	Values	Page
n6-01 (0570)	Online Tuning Selection	Online Tune Sel 0: Disabled 1: TerminalResAdj 2: VoltageAdjustm	<b>OLV</b> 0: Disabled 1: Line-to-line resistance tuning 2: Voltage correction. Setting not possible when Energy Saving is enabled (b8-01).	Default: 0 Range: 0 to 2	–
n6-05 (05C7)	Online Tuning Gain	R1 Comp Gain	<b>OLV</b> Decrease this setting for motors with a relatively large rotor time constant. If overload occurs, increase this setting slowly in increments of 0.10.	Default: 1.0 Min.: 0.1 Max.: 50.0	–

## B.11 o: Operator-Related Settings

The o parameters set up the HOA keypad displays.

### ◆ o1: HOA Keypad Display Selection

No. (Addr. Hex)	Name	LCD Display	Description	Values	Page
o1-01 (0500) RUN	Drive Mode Unit Monitor Selection	User Monitor Sel	Selects the content of the last monitor that is shown when scrolling through Drive Mode display. Enter the last three digits of the monitor parameter number to be displayed: U□-□□.	Default: 106 (Monitor U1-06) Range: 104 to 699	-
o1-02 (0501) RUN	User Monitor Selection after Power Up	Power-On Monitor 1: Frequency Ref 2: FWD/REV 3: Output Freq 4: Output Current 5: User Monitor	1: Frequency reference (U1-01) 2: Direction 3: Output frequency (U1-02) 4: Output current (U1-03) 5: User-selected monitor (set by o1-01)	Default: 1 Range: 1 to 5	-
o1-03 (0502)	Digital Operator Display Selection	Display Unit Sel 0: 0.01 Hz 1: 0.01% 2: r/min 3: User Units	Sets the units the drive should use to display the frequency reference and motor speed monitors. 0: 0.01 Hz 1: 0.01% (100% = E1-04) 2: r/min (calculated using the number of motor poles setting in E2-04) 3: User-selected units (set by o1-09, o1-10 and o1-11)	Default: 0 Range: 0 to 3	-
o1-05 (0504) RUN	LCD Contrast Control	LCD Contrast	Sets the contrast of the LCD operator.	Default: </> Range: 0, 1	-
o1-06 (0517)	User Monitor Selection Mode	Monitor Mode Sel 0: 3 Mon Sequential 1: 3 Mon Selectable	Selects the monitors displayed on the second and third lines of the digital operator display. 0: 3 Monitor Sequential (displays the next two sequential monitors) 1: 3 Monitor Selectable (set by o1-07 and o1-08)	Default: 1 Range: 0, 1	-
o1-07 (0518)	Second Line Monitor Selection	2nd Monitor Sel	Selects the monitor that is shown in the second line. Enter the last three digits of the monitor parameter number to be displayed: U□-□□. For example, set "403" to display monitor parameter U4-03. <b>Note:</b> Parameter is effective only when o1-06 is set to 1.	Default: 102 Range: 101 to 699	-
o1-08 (0519)	Third Line Monitor Selection	3rd Monitor Sel	Selects the monitor that is shown in the third line. Enter the last three digits of the monitor parameter number to be displayed: U□-□□. For example, set "403" to display monitor parameter U4-03. <b>Note:</b> Parameter is effective only when o1-06 is set to 1.	Default: 191 Range: 101 to 699	-
o1-09 (051C)	Frequency Reference Display Units	Fref Disp Unit 0: "WC:InchOfWater 1: PSI :lb/SqrInch 2: GPM:Gallons/Min 3: °F:DegFahrenheit 4: CFM:Cubic ft/Min 5: CMH:Cubic m/Hr 6: LPH:Litres/Hr 7: LPS:Litres/Sec 8: Bar:Bar 9: Pa:Pascals 10: °C:DegCelsius 11: m: meters 12: ft: feet 13: LPM:Litres/Min 14: CMM:Cubic M/Min 15: "Hg:Inch Mercury 24: Custom Unit 25: No Unit	Sets unit display for the frequency reference parameters and frequency related monitors when o1-03 = 3. 0: WC (Inch of water) 1: PSI (Pounds per square inch) 2: GPM (Gallons per minute) 3: F (Degrees Fahrenheit) 4: CFM (Cubic feet per minute) 5: CMH (Cubic meters per hour) 6: LPH (Liters per hour) 7: LPS (Liters per second) 8: Bar (Bar) 9: Pa (Pascal) 10: C (Degrees Celsius) 11: Mtr (Meters) 12: Ft (Feet) 13: LPM (Liters per minute) 14: CMM (Cubic meters per minute) 15: "Hg (inches of mercury) 24: Custom units (determined by o1-13 to o1-15) 25: None	Default: 25 Range: 0 to 15; 24, 25	-

No. (Addr. Hex)	Name	LCD Display	Description	Values	Page
o1-10 (0520)	User-Set Display Units Maximum Value	UserDisp Scaling	These settings define the display values when o1-03 is set to 3. o1-10 sets the display value that is equal to the maximum output frequency. o1-11 sets the position of the decimal position.	Default: </> Range: 1 to 60000	-
o1-11 (0521)	User-Set Display Units Decimal Display	UserDisp Dec Sel		Default: </> Range: 0 to 3	-
o1-12 (0522) [RUN]	Home Help Text	Top Help on Home 0: Disabled 1: Enabled	Switches the top line of the Home Screen from the Drive Status to defined Help messages. 0: Disabled 1: Enabled	Default: 1 Range: 0, 1	-
o1-13 (3105)	Frequency Reference and Frequency Related Monitor Custom Units 1	Fref Cust Unit 1	Sets the first character of the customer-specified unit display when o1-03 is set to 3 and o1-09 is set to 24.	Default: 41 Range: 20 to 7A	-
o1-14 (3106)	Frequency Reference and Frequency Related Monitor Custom Units 2	Fref Cust Unit 2	Sets the second character of the customer-specified unit display when o1-03 is set to 3 and o1-09 is set to 24.	Default: 41 Range: 20 to 7A	-
o1-15 (3107)	Frequency Reference and Frequency Related Monitor Custom Units 3	Fref Cust Unit 3	Sets the third character of the customer-specified unit display when o1-03 is set to 3 and o1-09 is set to 24.	Default: 41 Range: 20 to 7A	-

<1> Default setting is determined by parameter A1-02, Control Method Selection.

### ◆ o2: HOA Keypad Keypad Functions

No. (Addr. Hex)	Name	LCD Display	Description	Values	Page
o2-02 (0506)	STOP Key Function Selection	Oper STOP Key 0: Disabled 1: Enabled	0: Disabled. STOP key is disabled in REMOTE operation. 1: Enabled. STOP key is always enabled.	Default: 1 Range: 0, 1	-
o2-03 (0507)	User Parameter Default Value	User Default Sel 0: No Change 1: Save User Init 2: Clear User Init	0: No change. 1: Set defaults. Saves parameter settings as default values for a User Initialization. 2: Clear all. Clears the default settings that have been saved for a User Initialization.	Default: 0 Range: 0 to 2	-
o2-04 (508)	Drive Model Selection	Inverter Model #	Enter the drive model. Setting required only if installing a new control board.	Default: Determined by drive capacity	-
o2-05 (0509)	Frequency Reference Setting Method Selection	Oper Ref Method 0: Disabled 1: Enabled	0: ENTER key must be pressed to enter a frequency reference. 1: ENTER key is not required. The frequency reference can be adjusted using the up and down arrow keys only.	Default: 0 Range: 0, 1	-
o2-06 (050A)	Operation Selection when Digital Operator is Disconnected	Oper Discon Det 0: Disabled 1: Enabled	0: The drive continues operating if the digital operator is disconnected. 1: An oPr fault is triggered and the motor coasts to stop.	Default: 1 Range: 0, 1	-
o2-07 (0527)	Motor Direction at Power Up when Using Operator	For/RevSel@PwrUp 0: Forward 1: Reverse	This parameter requires assigning drive operation to the digital operator. 0: Forward 1: Reverse	Default: 0 Range: 0, 1	-
o2-19 (061F)	Parameter Set Selection	ParameterSet Sel 0: Disabled 1: Enabled	Selects whether parameter settings can be changed during a DC bus undervoltage condition. To be used with 24 V Power Supply option (PS-A10L, PS-A10H) revision B or later. 0: Disabled 1: Enabled  <b>Note:</b> 1. This parameter is not available in models 4A0930 and 4A1200. 2. Enabling this function may trigger a CPF06 fault when used with a 24 V Power Supply option revision earlier than B, as the parameter changes might not occur correctly.	Default: 0 Range: 0, 1	-

## B.11 o: Operator-Related Settings

No. (Addr. Hex)	Name	LCD Display	Description	Values	Page
o2-30 (1230) <b>RUN</b>	Monitor Position Save	Mon Pos Save 0: Disabled 1: Enabled	Saves the monitor position and Home Screen quick monitor selection. Setting this parameter to 0 and then entering the Monitor Menu will jump the selection to the monitor number instead of the group number. 0: Disabled 1: Enabled	Default: 0 Range: 0, 1	–

### ◆ o3: Copy Function

No. (Addr. Hex)	Name	LCD Display	Description	Values	Page
o3-01 (0515)	Copy Function Selection	Copy Function Sel 0: COPY SELECT 1: INV→OP READ 2: OP→INV WRITE 3: OP←→INV VERIFY	0: No action 1: Read parameters from the drive, saving them onto the digital operator. 2: Copy parameters from the digital operator, writing them to the drive. 3: Verify parameter settings on the drive to check if they match the data saved on the operator.	Default: 0 Range: 0 to 3	–
o3-02 (0516)	Copy Allowed Selection	Read Allowable 0: Disabled 1: Enabled	0: Read operation prohibited 1: Read operation allowed	Default: 1 Range: 0, 1	–

### ◆ o4: Maintenance Monitor Settings

No. (Addr. Hex)	Name	LCD Display	Description	Values	Page
o4-01 (050B)	Cumulative Operation Time Setting	DrvElapsTimeCnt	Sets the value for the cumulative operation time of the drive in units of 10 h.	Default: 0 Min.: 0 Max.: 9999	–
o4-02 (050C)	Cumulative Operation Time Selection	ElapsTimeCntSet 0: Power-On Time 1: Running Time	0: Logs power-on time 1: Logs operation time when the drive output is active (output operation time).	Default: 1 Range: 0, 1	–
o4-03 (050E)	Cooling Fan Operation Time Setting	FanElapsTimeCn	Sets the value of the fan operation time monitor U4-03 in units of 10 h.	Default: 0 Min.: 0 Max.: 9999	–
o4-05 (051D)	Capacitor Maintenance Setting	BusCap Maint Set	Sets the value of the Maintenance Monitor for the capacitors. See U4-05 to check when the capacitors may need to be replaced.	Default: 0% Min.: 0 Max.: 150	–
o4-07 (0523)	DC Bus Pre-Charge Relay Maintenance Setting	ChrgCircMaintSet	Sets the value of the Maintenance Monitor for the soft charge bypass relay. See U4-06 to check when the bypass relay may need to be replaced.	Default: 0% Min.: 0 Max.: 150	–
o4-09 (0525)	IGBT Maintenance Setting	IGBT Maint Set	Sets the value of the Maintenance Monitor for the IGBTs. See U4-07 for IGBT replacement times.	Default: 0% Min.: 0 Max.: 150	–
o4-11 (0510)	U2, U3 Initialization	Fault Data Init 0: Disabled 1: Enabled	0: U2-□□ and U3-□□ monitor data is not reset when the drive is initialized (A1-03). 1: U2-□□ and U3-□□ monitor data is reset when the drive is initialized (A1-03).	Default: 0 Range: 0, 1	–
o4-12 (0512)	kWh Monitor Initialization	kWh Monitor Init 0: No Reset 1: Reset	0: U4-10 and U4-11 monitor data is not reset when the drive is initialized (A1-03). 1: U4-10 and U4-11 monitor data is reset when the drive is initialized (A1-03).	Default: 0 Range: 0, 1	–
o4-13 (0528)	Number of Run Commands Counter Initialization	Run Counter Init 0: No Reset 1: Reset	0: Number of Run commands counter is not reset when the drive is initialized (A1-03). 1: Number of Run commands counter is reset when the drive is initialized (A1-03).	Default: 0 Range: 0, 1	–
o4-17 (3100)	Set/Reset Real-Time Clock	Date/Time Config 0: — — 1: Set 2: Reset	Sets the current date and time for the Real-Time Clock. 0: — — 1: Set 2: Reset	Default: 0 Range: 0 to 2	136



No. (Addr. Hex)	Name	LCD Display	Description	Values	Page
o4-20 (081F)	Time Display Format	Time Disp Format 0: 12-hour (AM/PM) 1: 24-hour	Sets the time display format. 0: 12-hour 1: 24-hour	Default: 0 Range: 0, 1	-

## B.12 P: Pump Parameters

### ◆ P1: Pump Basic

No. (Addr. Hex)	Name	LCD Display	Description	Values	Page
P1-01 (0C00)	Pump Mode	Pump Mode 0: Drive Only 1: Contactor Lag 3: Memobus Network	0: Drive only 1: Contactor lag 3: MEMOBUS network	Default: 0 Range: 0, 1, 3	230
P1-02 (0C01)	System Units	System Units 0: No Unit 1: PSI :lb/SqrInch 2: Pa:Pascals 3: Bar:Bar 4: "WC:InchOfWater 5: "Hg:Inch Mercury 6: ft: feet 7: m: meters 8: °F:DegFarenheit 9: °C:DegCelsius 10: %: Percent 11: kPA: kilopascal 25: Flow (use P6-04) 26: Custom(P1-32~34)	0: No unit 1: PSI: Pounds per square inch 2: Pa: Pascals 3: Bar: Bar 4: "WC: Inch of water 5: "Hg: Inch of Mercury 6: ft: feet 7: m: meters 8: °F: Degrees Fahrenheit 9: °C: Degrees Celsius 10: Percent 11: kPA: kilopascal <1> 25: Flow (Use P6-04) <2> 26: Custom units	Default: 1 Range: 0 to 11; 25, 26	230
P1-03 (0C02)	Feedback Device Scaling	FB Dev. Scaling	Sets the scaling of feedback device in user-set units.	Default: 145.0 PSI <3> Min.: 0.1 Max.: 6000.0	231
P1-04 (0C03) [RUN]	Start / Draw Down Level	Start-DrawDn Lvl	The system starts when the feedback level drops below the start level for the time set in P1-05. This level also specifies the wake-up level when the drive is in Sleep Mode. When this parameter is set to a negative value, the feedback level must drop that amount below the setpoint. Setting this parameter to 0.0 disables the function. When P1-01, Pump Mode, is set to 3 (MEMOBUS network), this function is active only on the first drive in the network.  <b>Note:</b> When PID operates in reverse mode, the system will start when the feedback has risen above the start level for the time set to P1-05.	Default: 0.0 PSI <3> Min.: 0.0 Max.: 999.9 <7>	231
P1-05 (0C02) [RUN]	Start Level Delay Time	S-Lev Delay Time	The system starts when the feedback level drops below the start level for the time set in this parameter.	Default: 1 s Min.: 0 Max.: 3600	231
P1-06 (0C05) [RUN]	Minimum Pump Speed	Min. Pump Speed	Minimum frequency at which the drive will run. Applies to both HAND and Automatic modes.  <b>Note:</b> For minimum pump frequency, the drive will use the highest setting from among P1-06, P4-12 (Thrust Bearing Frequency), or d2-02 (Reference Lower Limit).	Default: 40.0 Hz <4> Min.: 0.0 Max.: [E1-04]	232
P1-07 (0C06) <4>	Minimum Pump Speed Units	MinPumpSpdUnits 0: Hz 1: RPM	Sets the units and decimal place for parameter P1-06. 0: Hz 1: RPM  <b>Note:</b> Changing this parameter will reset the P1-06 default value.	Default: 0 Range: 0, 1	–
P1-08 (0C07) [RUN]	Low Feedback Level	Low FB Level	Sets the lower detection level for the PID feedback.	Default: 0.0 PSI <3> Min.: 0.0 Max.: 999.9 <8>	232

No. (Addr. Hex)	Name	LCD Display	Description	Values	Page
P1-09 (0C08) <u>RUN</u>	Low Feedback Level Fault Delay Time	Low Lvl FLT Time	Sets the amount of delay time from when the low feedback is detected until the drive faults on an “LFB Low Feedback” fault. <b>Note:</b> 1. This parameter is effective only when P1-10 is set to 0 (Fault). 2. When P1-01 is set to 3, parameter P9-18 uses this value to calculate the quick de-stage feedback level.	Default: 10 s Min.: 0 Max.: 3600	232
P1-10 (0C09)	Low Feedback Selection	Low FB Sel 0: Fault 1: Alarm 2: Digital Output	Selects drive response during the “Low Feedback” condition. 0: Fault 1: Alarm 2: Digital out only	Default: 0 Range: 0 to 2	232
P1-11 (0C0A) <u>RUN</u>	High Feedback Level	High FB Level	Sets the upper detection level for the PID feedback.	Default: 155.0 PSI <3> Min.: 0.0 Max.: 999.9 <9>	232
P1-12 (0C0B) <u>RUN</u>	High Feedback Level Fault Delay Time	High Lvl FLT Time	Sets the amount of delay time from when the high feedback is detected until the drive faults on a “HFB High Feedback” fault. <b>Note:</b> This parameter is effective only when P1-13 is set to 0 (Fault (and digital out)).	Default: 5 s Min.: 0 Max.: 3600	233
P1-13 (0C0C)	High Feedback Selection	High FB Sel 0: Fault 1: Alarm 2: Digital Output	Selects drive response during the “High Feedback” condition. 0: Fault 1: Alarm 2: Digital out only	Default: 0 Range: 0 to 2	233
P1-14 (0C0D) <u>RUN</u>	Hysteresis Level	Hysteresis Level	Sets the hysteresis level used for low and high level feedback detection.	Default: 0.0 PSI <> Min.: 0.0 Max.: 100.0	–
P1-15 (0C0E) <u>RUN</u>	Maximum Setpoint Difference	Max Set Pnt Diff	Sets the level that the difference between the setpoint and the feedback must exceed for the time set in P1-16 to trigger the drive response set in P1-17. If P1-17 is set to 1 (Fault and digital out), the drive will coast to stop. This function is active when the drive is running during AUTO Mode. When P1-01 is set to 3 (MEMOBUS network), the function is active on the lead drive and will stop all drives running on the network when The NMS fault occurs. Setting this parameter to 0.0 disables the function.	Default: 0.0 PSI <> Min.: 0.0 Max.: 6000.0	–
P1-16 (0C0F) <u>RUN</u>	Not Maintaining Setpoint Time	Not Maint SP Tm	Sets the delay time before a “Setpoint Not Met” condition occurs. The pump protection criteria set in P1-15 must be met before the timer will start. Setting P1-15 to 0.0 disables this function.	Default: 60 s Min.: 0 Max.: 3600	–
P1-17 (0C10)	Not Maintaining Setpoint Selection	Not Maint SP Sel 0: Fault 1: Alarm 2: Digital Output	Selects the drive response method during the “Not Maintaining Setpoint” condition. 0: Fault 1: Alarm 2: Digital out only	Default: 0 Range: 0 to 2	–
P1-18 (0C11)	Prime Loss Detection Method	Prime Loss Mthd 0: Current (A) 1: Power (kW) 2: Torque (%)	Determines the quantity used to determine loss of prime.	Default: 0 Range: 0 to 2	–
P1-19 (0C12) <u>RUN</u>	Prime Loss Level	Prime Loss Level	Detects loss of prime in the pump when in Auto or Sleep Boost Mode. When the measured quantity determined by P1-18 drops below this level for the time set in P1-20 and the output frequency is above the level set in P1-21, a “Loss of Prime” condition occurs. The drive responds to the “Loss of Prime” condition depending on the setting of P1-22, Loss of Prime Selection.	Default: 0.0 A <> Min.: 0.0 Max.: 1000.0	–
P1-20 (0C13) <u>RUN</u>	Loss of Prime Time	Prime Loss Time	Sets the delay time before a “Loss of Prime” condition occurs. The pump protection criteria set in P1-18 and P1-19 must be met before the timer will start.	Default: 20 s Min.: 0 Max.: 600	–
P1-21 (0C14)	Loss of Prime Frequency	Prime Loss Freq	Sets the frequency level above which the “Loss of Prime” detection is enabled when set to a value other than 0. When set to 0 (default), the frequency level is determined by the smaller value between (Fmax - 1 Hz) and (d2-01 - 1 Hz).	Default: 0.0 Hz Min.: 0.0 Max.: [E1-04]	–

## B.12 P: Pump Parameters

No. (Addr. Hex)	Name	LCD Display	Description	Values	Page
P1-22 (0C15)	Loss of Prime Selection	Prime Loss Sel 0: Fault 1: Alarm 2: Digital Output	Sets the drive response method during the “Loss of Prime” condition. 0: Fault 1: Alarm 2: Digital out only	Default: 0 Range: 0 to 2	–
P1-23 (0C16)	Loss of Prime Maximum Restart Time after Fault	LOP Max Rstrt T	Sets the time in minutes that the drive will wait before attempting another restart when the restart fails or is not attempted due to a continuing fault condition.	Default: 0.2 min Min.: 0.2 Max.: 6000.0	–
P1-24 (0C17) <6>	Level at Full Speed	Level @ Full Spd	When set greater than 0, this level is used to override the P-gain and I-limit with a calculated value based on Sleep level, Wake-up level, Minimum Pump Speed, Transducer Scaling, and Maximum Frequency. This feature is disabled when set to 0.	Default: 0.0 Min.: 0.0 Max.: 6000.0	–
P1-30 (0C1D)	Low Water Digital Input Configuration	Low Water DI Sel 0: Normally Open 1: Normally Closed	Selects the configuration of the low water level digital input. 0: Normally open 1: Normally closed	Default: 0 Range: 0, 1	–
P1-31 (0C1E)	High Water Digital Input Configuration	HighWater DI Sel 0: Normally Open 1: Normally Closed	Selects the configuration of the high water level digital input. 0: Normally open 1: Normally closed	Default: 0 Range: 0, 1	–
P1-32 (0C1F) <6>	System Units Custom 1st Character	Sys Unit Custom1	Sets the first character of the custom unit display when P1-02 = 26.	Default: 41 Min.: 20 Max.: 7A	–
P1-33 (0C20) <6>	System Units Custom 2nd Character	Sys Unit Custom2	Sets the second character of the custom unit display when P1-02 = 26.	Default: 41 Min.: 20 Max.: 7A	–
P1-34 (0C21) <6>	System Units Custom 3rd Character	Sys Unit Custom3	Sets the third character of the custom unit display when P1-02 = 26.	Default: 41 Min.: 20 Max.: 7A	–
P1-40 (0C27) RUN <10>	Maximum Pump Speed	Max Pump Speed	Sets the maximum pump speed. This parameter does not affect operation when set to 0.0 or when set to a value higher than E1-04 x d2-01. This parameter is internally lower limited to the minimum pump speed (P1-06, P4-12, d2-02) when not set to 0.0.	Default: 0.0 Hz Min.: 0.0 Max.: 440.0	233

<1> Available in drive software versions PRG: 8554 and later. Not available in drive models 4A0930 and 4A1200.

<2> System units are set by P6-04, Water Flow Units. The PID Feedback is re-routed to come from the flow meter, pulse input (H6-01 = 5), or analog (H3-0□ = 22).

<3> Unit text is set by P1-02, System Units.

<4> Unit range and resolution are determined by P1-07, Minimum Pump Speed Units. Setting P1-07 to 1 (RPM) will set a default value of 900 RPM (VTC) and 2400 RPM (all others). Setting P1-07 to 0 (Hz, default) will set a default value of 40.0 Hz.

<5> Unit text is set by P1-18, Prime Loss Detection Method.

<6> Available in drive software versions PRG: 8551 and later.

<7> Range is 0.0 to 999.9 with sign-bit “-” or “+” indicating Delta to Setpoint. Range is -999.9 to 999.9 in drive software versions PRG: 8551 and earlier.

<8> Range is 0.0 to 999.9 with sign-bit “-” indicating Delta to Setpoint. Range is 0.0 to 6000.0 in drive software versions PRG: 8551 and earlier.

<9> Range is 0.0 to 999.9 with sign-bit “+” indicating Delta to Setpoint. Range is 0.0 to 6000.0 in drive software versions PRG: 8551 and earlier.

<10> Available in drive software versions PRG: 8552 and later. Not available in drive models 4A0930 and 4A1200.

◆ P2: Pump Protection

No. (Addr. Hex)	Name	LCD Display	Description	Values	Page
P2-01 (0C64)	Sleep Level Type	Sleep Lvl Type 0: Output Frequency 1: Output Current 2: Feedback 3: Output Speed-RPM 4: Flow Meter	0: Output frequency 1: Output current 2: Feedback 3: Output speed (RPM) 4: Flow meter (requires flow meter)  <b>Note:</b> Feedback depends on PID direction operation.	Default: 0 Range: 0 to 4	233
P2-02 (0C65) [RUN]	Sleep Level	Sleep Level	Sleep activates when the selected level type (P2-01 setting) reaches the programmed sleep level for the time set in P2-03. This function is active when the drive is running during AUTO Mode. When P1-01 is set to 3 (MEMOBUS network), the function is active when there is only one drive running on the network. Setting this parameter below minimum pump speed (P1-06) disables Sleep Level (P2-02) and sleep activates at minimum pump speed.	Default: 0.0 Hz </> Min.: 0.0 Max.: 6000.0	234
P2-03 (0C66) [RUN]	Sleep Delay Time	Sleep Delay Time	Sets the delay time before the drive enters Sleep Mode when the sleep level set in P2-02 is reached.	Default: 5 s Min.: 0 Max.: 3600	234
P2-04 (0C67) [RUN]	Sleep Activate Level	Sleep Act. Level	Sets the level above which the output frequency must rise to activate the sleep function when P2-01, Sleep Level Type, is set to 0 (Output Frequency / Speed). Setting this parameter to 0.0 disables the function and the sleep function will activate when P2-02, Sleep Level, is reached.	Default: 0.0 Hz </> Min.: 0.0 Max.: 6000.0	–
P2-05 (0C68) [RUN]	Sleep Boost Level	Sleep Boost Lvl	Sets the amount of boost applied to the setpoint before going to sleep. Setting this parameter to 0.0 disables the function.	Default: 0.0 PSI </> Min.: 0.0 Max.: 6000.0	–
P2-06 (0C69) [RUN]	Sleep Boost Hold Time	SleepBoost HldTm	Sets the amount of time that the boosted pressure will be maintained before the drive goes to sleep.	Default: 5.0 s Min.: 0.5 Max.: 160.0	–
P2-07 (0C6A) [RUN]	Sleep Boost Maximum Time	SleepBoost MaxTm	Sets the amount of time that the system (feedback) has to reach the boosted setpoint. The drive will go to sleep when the amount of time set in this parameter has been exceeded.	Default: 20.0 s Min.: 1.0 Max.: 160.0	–
P2-08 (0C6B) [RUN]	Delta Sleep Feedback Drop Level	D Fb Drop Level	If the PID Error (setpoint minus feedback) exceeds the level programmed in this parameter within the time window set in P2-09 and the output frequency is greater than the level set in P1-06, the sleep operation deactivates and the drive returns to normal operation. Setting this parameter to 0.0 disables the function.	Default: 0.0 PSI </> Min.: 0.0 Max.: 6000.0	–
P2-09 (0C6C) [RUN]	Feedback Detection Drop Time	FB Drop Det. Time	Defines the time window in which the software monitors the feedback to detect a flow/no-flow condition.	Default: 10.0 s Min.: 0.0 Max.: 3600.0	–
P2-10 (0C6D) [RUN]	Sleep Mode: Cycling Protection	Cycle Protection	Sets the maximum number of cycles that are allowed within the time specified in P2-11 before tripping the PoC “Pump Over Cycle” fault. One cycle is defined when the drive transfers from normal operation in AUTO Mode to Sleep Mode. This function is active when the drive is running during AUTO Mode. When P1-01 is set to 3 (MEMOBUS network), the function is active when there is only one drive running on the network. Setting this parameter to 0 disables the function.	Default: 0 Min.: 0 Max.: 10	–
P2-11 (0C6E) [RUN]	Sleep Mode: Maximum Cycling Protection Time	Max. Cycle Time	Sets the maximum time allowed between cycles. When no cycling occurs within the programmed time, the drive will decrease the internal cycle register.	Default: 300 s Min.: 0 Max.: 3600	–
P2-12 (0C6F)	Over Cycling Mode	Over Cycle Mode 0: Disabled 1: Alarm Only 2: Fault 3: Auto SP Comp.	0: Disabled 1: Alarm 2: Fault 3: Auto SP Compensation	Default: 0 Range: 0 to 3	–

## B.12 P: Pump Parameters

No. (Addr. Hex)	Name	LCD Display	Description	Values	Page
P2-13 (0C70)	Setpoint Compensation	Setpoint Comp.	Allows for the software to automatically compensate the setpoint in the event of excessive cycling.	Default: 0.0 PSI <3> Min.: 0.0 Max.: 6000.0	–
P2-14 (0C71)	Maximum Setpoint Compensation	Max. SP Comp.	Sets the maximum allowed setpoint compensation for over-cycling function.	Default: 0.0 PSI <3> Min.: 0.0 Max.: 6000.0	–
P2-15 (0C72) RUN <4>	Sleep AUTO -> Off Selection	Sleep AUTO->Off 0: Disabled 1: Enabled	Enabling this parameter activates Sleep if the P1-04 Start Level is set to 0 and switches the drive to OFF mode when called to Sleep. 0: Disabled 1: Enabled	Default: 0 Range: 0, 1	234
P2-23 (0C7A) RUN	Anti-No-Flow Bandwidth	ANF Bandwidth	Sets the amount of PI error bandwidth used to detect the Anti-No-Flow condition. Avoid setting this parameter value too high, as operation may become unstable. Setting this parameter to 0.00 will disable the function.	Default: 0.40% Min.: 0.00 Max.: 2.00	–
P2-24 (0C7B) RUN	Anti-No-Flow Detection Time	ANF Det. Time	Sets the time delay before the drive starts the increased deceleration rate after Anti-No-Flow is detected.	Default: 10.0 s Min.: 1.0 Max.: 60.0	–
P2-25 (0C7C) RUN	Anti-No-Flow Release Level	ANF Release Lvl	Sets the amount below the setpoint which the feedback must drop to disengage the Anti-No-Flow and return to normal PI operation.	Default: 3.0 PSI <3> Min.: 0.0 Max.: 100.0	–

<1> Display units vary depending on the setting for P2-01, Sleep Level Type. When P2-01 is set to 0, the display units are “Hz”; setting 1 is “A”; setting 2 is P1-02 Selection; setting 3 is “RPM”; setting 4 is P6-04 selection.

<2> Display units vary depending on the setting for P2-01, Sleep Level Type. When P2-01 is set to 0, 1, 2, or 4, the display units are “Hz”; setting 3 is “RPM”.

<3> Unit is determined by P1-02, System Units, setting.

<4> Available in drive software versions PRG: 8552 and later. Changes during Run in drive software versions PRG: 8554 and later. Not available in drive models 4A0930 and 4A1200.

## ◆ P3: Contactor Multiplexing

No. (Addr. Hex)	Name	LCD Display	Description	Values	Page
P3-00 (0CC7)	Number of Lag Pumps	Num of Lag Pumps	Sets the number of lag pumps present.	Default: 1 Min.: 1 Max.: 5	234
P3-01 (0CC8)	Add Pump Control	Add Pump Control 0: Output Frequency 1: Feedback 2: Feedback + Fout	Selects the method for adding contactor pumps to the system. 0: Output frequency (Uses P3-03 and P3-05) 1: Feedback (Uses P3-04 and P3-05) 2: Feedback + Fout (Uses P3-03, P3-04, and P3-05)	Default: 0 Range: 0 to 2	–
P3-02 (0CC9)	Shutdown Pump Control	Shutdown Pump Ctl 0: Output Frequency 1: Feedback 2: Feedback + Fout	Selects the method for removing contactor pumps from the system. 0: Output frequency (Uses P3-09, P3-50 P3-60, P3-70, P3-80, and P3-90) 1: Feedback (Uses P3-08 and P3-09) 2: Feedback + Fout (Uses P3-08, P3-09, P3-50, P3-60, P3-70, P3-80, and P3-90)	Default: 0 Range: 0 to 2	–

No. (Addr. Hex)	Name	LCD Display	Description	Values	Page
P3-03 (0CCA) [RUN]	Drive Multi/Maximum Level	Max-Multi Level	Sets the maximum level used for the multiplex pumping operation. Parameter is active only when P3-01 is set to 0 or 2. When P3-01 is set to 0, the next available pump will be added to the system by a multi-function Discrete Output closure (H2-0□ = 80 to 84) when the output frequency rises above the level set in this parameter for the time set in P3-05. When P3-01 is set to 2, the next available pump will be added to the system by a multi-function Discrete Output closure (H2-0□ = 80 to 84) when the output frequency rises above the level set in this parameter and the delta feedback (setpoint minus feedback) has exceeded the level programmed in P3-04 for the time set in P3-05.	Default: 59.0 Hz Min.: 0.0 Max.: 400.0	–
P3-04 (0CCB) [RUN]	Add Pump Delta Level	Add Pump D-Lvl	Sets the level used for the multiplex pumping operation. Parameter is active only when P3-01 is set to 1 or 2. When P3-01 is set to 1, the next available pump will be added to the system by a multi-function Discrete Output closure (H2-0□ = 80 to 84) when the delta feedback (setpoint minus feedback) has exceeded the level set in this parameter for the time set in P3-05. When P3-01 is set to 2, the next available pump will be added to the system by a multi-function Discrete Output closure (H2-0□ = 80 to 84) when the output frequency rises above the level set in P3-03 and the delta feedback (setpoint minus feedback) has exceeded the level set in this parameter for the time set in P3-05. <b>Note:</b> Programming this parameter too close to the system setpoint may cause the pump system to cycle excessively.	Default: 0.0 PSI </> Min.: 0.0 Max.: 6000.0	–
P3-05 (0CCC) [RUN]	Add Pump Delay Time	Add Pump Dly Tm	Sets the delay time before a pump is added to the system.	Default: 2 s Min.: 0 Max.: 3600	–
P3-06 (0CCD) [RUN]	Frequency Reduction after Staging	FreqReduce@Stage	Sets the upper limit of the output frequency after a lag pump is staged. The upper limit of the output frequency is calculated by subtracting the value of this parameter from parameter P3-03. Output limit = P3-03 - P3-06	Default: 0.0 Hz Min.: 0.0 Max.: 30.0	–
P3-07 (0CCE) [RUN]	Frequency Reduction after Staging Time	FreqReduce Time	Sets the amount of time that the output frequency will be limited after lag pump is staged.	Default: 0.0 s Min.: 0.0 Max.: 240.0	–
P3-08 (0CCF) [RUN]	Shutdown Pump Delta Level	Shdn Pump D-Lvl	Sets the level used for the multiplex pumping operation. Parameter is active only when P3-02 is set to 1 or 2. When P3-02 is set to 1, the last pump that was brought online will be shut down by opening the dedicated multi-function discrete output (H2-0□ = 80 to 84) when the delta feedback (feedback minus setpoint) has exceeded the level programmed in this parameter for the time set in P3-09. When the P3-02 is set to 2, the last pump that was brought online will be shut down by opening the dedicated multi-function discrete output (H2-0□ = 80 to 84) when the output frequency drops below the level programmed in P3-50, P3-60, P3-70, P3-80, or P3-90 and the delta feedback (feedback minus setpoint) has exceeded the level set in this parameter for the time set in P3-09. <b>Note:</b> Programming this parameter too close to the system setpoint may cause the pump system to cycle excessively.	Default: 0.0 PSI </> Min.: 0.0 Max.: 6000.0	–
P3-09 (0CD0) [RUN]	Shutdown Pump Delay Time	Shdn Pump Dly Tm	Sets the delay time before one of the additional line pumps is shut down.	Default: 5 s Min.: 0 Max.: 3600	–
P3-10 (0CD1) [RUN]	Setpoint Boost Maximum at De-Stage	MaxBoost@DeStage	Sets the maximum amount of boost that can be added to the setpoint after a de-stage occurs. Setting this parameter to 0.0 disables the function.	Default: 0.0 PSI </> Min.: -20.0 Max.: 20.0	–

## B.12 P: Pump Parameters

No. (Addr. Hex)	Name	LCD Display	Description	Values	Page
P3-11 (0CD2) [RUN]	Setpoint Boost after De-Stage Time	SP Boost Time	Sets the amount of time that the setpoint will remain boosted after lag pump is de-staged.	Default: 5.0 s Min.: 0.0 Max.: 60.0	–
P3-12 (0CD3) [RUN]	Multi Pump Setpoint Increase during Transition	MP Setpoint Inc	Sets the system setpoint increase each time a new pump is brought online. Pump 1: Setpoint Pump 1 + 2: Setpoint + P3-12 Pump 1 + 2 + 3: Setpoint + 2 x P3-12	Default: 0.0 PSI </> Min.: 0.0 Max.: 6000.0	–
P3-13 (0CD4) [RUN]	Multi Pump Setpoint Decrease during Transition	MP Setpoint Dec	Sets the system setpoint decrease each time a new pump is brought online. Pump 1: Setpoint Pump 1 + 2: Setpoint - P3-13 Pump 1 + 2 + 3: Setpoint - 2 x P3-13	Default: 0.0 PSI </> Min.: 0.0 Max.: 6000.0	–
P3-14 (0CD5) [RUN]	Multiplex Stabilization Time	M-Stabilize Time	Sets the time used to stabilize the system when a pump is added or shut down during multiplex operation. When a pump is added, the stabilize timer temporarily disables the lead/lag functionality for the programmed time to prevent pump cycling. Function is active in contactor multiplex mode (P1-01 = 1). Time pump protection and lead/lag control is suspended during stabilization time.	Default: 2 s Min.: 0 Max.: 3600	–
P3-15 (0CD6) [RUN] </>	High Feedback Quick De-stage	High FB De-stage	Sets the High Feedback level that will trigger a quick de-stage. The quick de-stage uses an internal 2 sec delay. A setting of 0 disables this feature.	Default: 0.0 PSI </> Min.: 0.0 Max.: 6000.0	–
P3-16 (0CD7) [RUN] </>	Low Feedback Quick De-stage	Low FB De-stage	Sets the Low Feedback level that will trigger a quick de-stage. The quick de-stage uses an internal 2 sec delay. A setting of 0 disables this feature.	Default: 0.0 PSI </> Min.: 0.0 Max.: 6000.0	–
P3-30 (0CE5)	Stage Selection Mode	Stage Sel Mode 0: Sequential 1: Stop History	Sets the method of staging for the pumps. 0: Sequential 1: Stop history	Default: 0 Range: 0, 1	–
P3-31 (0CE6)	De-Stage Selection Mode	Destage Sel Mode 0: LastInFirstOut 1: FirstInFirstOut	Sets the method for removing contactor pumps. 0: Last in, first out (LIFO) 1: First in, first out (FIFO)	Default: 0 Range: 0, 1	–
P3-40 (0CEF)	Pre-Charge Lag Pump Select	Precharge LagSel 0: Disabled 2: Pump2 (H2-0X=80) 3: Pump3 (H2-0X=81) 4: Pump4 (H2-0X=82) 5: Pump5 (H2-0X=83) 6: Pump6 (H2-0X=84)	Selects which of the lag pumps can come on during a pre-charge. 0: Disabled 2: Pump 2 (H2-0□ = 80) 3: Pump 3 (H2-0□ = 81) 4: Pump 4 (H2-0□ = 82) 5: Pump 5 (H2-0□ = 83) 6: Pump 6 (H2-0□ = 84)	Default: 0 Range: 0; 2 to 6	–
P3-41 (0CF0)	Pre-Charge Lag Pump Run Time	Precharge Lag Tm	Sets the length of time that the lag pump specified in P3-40 is energized.	Default: 0.0 min Min.: 0.0 Max.: 3600.0	–
P3-42 (0CF1)	Post-Pre-Charge Lag Pump Operation	Post PreChg Lag 0: Turn Off 1: Continue	Determines whether the lag pump set in pre-charge (P3-40) turns off or maintains its state when pre-charge is completed. 0: Turn off 1: Continue	Default: 0 Range: 0, 1	–
P3-43 (0CF2)	Pre-Charge Lag Pump Delay Time	PreChg Lag Delay	Sets the length of time that the drive is in the pre-charge mode before the lag pump set in P3-40 is energized.	Default: 2.0 min Min.: 0.0 Max.: 600.0	–
P3-50 (0CF9) [RUN]	Pump 2 Frequency Shutdown Level	P2 Shutdown Freq	Sets the level used for the multiplex pumping operation. Parameter is active only when P3-02 is set to 0 or 2. When P3-02 is set to 0 and a total of two pumps are running, the last pump (Pump 2) that was brought online will be shut down by opening the dedicated multi-function discrete output (H2-0□ = 80 to 84) when the output frequency falls below the level set in this parameter for the time set in P3-09. When P3-02 is set to 2 and a total of two pumps are running, the last pump (Pump 2) that was brought online will be shut down by opening the dedicated multi-function discrete output (H2-0□ = 80 to 84) when the delta feedback (setpoint minus feedback) has exceeded the level programmed in this parameter for the time set in P3-09.	Default: 40.0 Hz Min.: 0.0 Max.: 400.0	234



No. (Addr. Hex)	Name	LCD Display	Description	Values	Page
P3-60 (11E5) RUN	Pump 3 Frequency Shutdown Level	P3 Shutdown Freq	Sets the level used for the multiplex pumping operation. Parameter is active only when P3-02 is set to 0 or 2. Parameter function is similar to P3-50, except for Pump 3 instead of Pump 2.	Default: 40.0 Hz Min.: 0.0 Max.: 400.0	235
P3-70 (11EF) RUN	Pump 4 Frequency Shutdown Level	P4 Shutdown Freq	Sets the level used for the multiplex pumping operation. Parameter is active only when P3-02 is set to 0 or 2. Parameter function is similar to P3-50, except for Pump 4 instead of Pump 2.	Default: 40.0 Hz Min.: 0.0 Max.: 400.0	235
P3-80 (11F9) RUN	Pump 5 Frequency Shutdown Level	P5 Shutdown Freq	Sets the level used for the multiplex pumping operation. Parameter is active only when P3-02 is set to 0 or 2. Parameter function is similar to P3-50, except for Pump 5 instead of Pump 2.	Default: 40.0 Hz Min.: 0.0 Max.: 400.0	–
P3-90 (1203) RUN	Pump 6 Frequency Shutdown Level	P6 Shutdown Freq	Sets the level used for the multiplex pumping operation. Parameter is active only when P3-02 is set to 0 or 2. Parameter function is similar to P3-50, except for Pump 6 instead of Pump 2.	Default: 40.0 Hz Min.: 0.0 Max.: 400.0	–

- <1> Unit is determined by P1-02, System Units, setting.
- <2> Available in drive software versions PRG: 8551 and later.

### ◆ P4: Pump Advanced

No. (Addr. Hex)	Name	LCD Display	Description	Values	Page
P4-01 (0CFA) RUN	Pre-Charge Level	Pre-Charge Level	Runs the drive at the frequency set in P4-02. The drive will stop when one of the following conditions occurs: <ul style="list-style-type: none"> <li>• The feedback level rises above the level set in P4-01</li> <li>• The pre-charge time set in P4-03 expires</li> <li>• The low water digital input is deactivated (#8F)</li> </ul>	Default: 0.0 PSI <> Min.: 0.0 Max.: 6000.0	235
P4-02 (0CFB) RUN	Pre-Charge Frequency	Pre-Charge Freq.	Sets the frequency reference used when the Pre-Charge function is active.	Default: 0.0 Hz Min.: 0.0 Max.: [E1-04]	235
P4-03 (0CFC) RUN	Pre-Charge Time	Pre-Charge Time	Sets the maximum allowed Pre-Charge time. When P1-01 is set to 3 (MEMOBUS network), the function is active only on the first drive to run in the network. Setting this parameter to 0.0 disables the function.	Default: 0.0 min Min.: 0.0 Max.: 3600.0	235
P4-04 (0CFD) <2>	Pre-Charge Message Style	Pre-Charge Msg 0: Full Screen Message 1: Home Mon Text	Selects how the “Pre-charge Active” message is displayed on the operator.	Default: 0 Range: 0, 1	238
P4-05 (0CFE) RUN	Pre-Charge Loss of Prime Level	Pre-Charge LOP	Detects loss of prime in the pump. When the measured quantity determined by P1-18 drops below this level for the time set in P1-20 and the output frequency is at the level set in P4-02, a “Loss of Prime” condition occurs. The drive responds to the “Loss of Prime” condition depending on the setting of P1-22, Loss of Prime Selection.	Default: 0.0 A <> Min.: 0.0 Max.: 1000.0	–
P4-06 (0CFF) RUN	Pre-Charge Frequency 2	Pre-Charge Freq2	Sets the frequency reference used when the Pre-Charge function 2 is active. Setting this parameter to 0.0 disables the function.	Default: 0.0 Hz Min.: 0.0 Max.: [E1-04]	–
P4-07 (0D00) RUN	Pre-Charge Time 2	Pre-Charge Time2	Sets the time at which the drive will spend at the Pre-Charge frequency 2 speed during pre-charge. Setting this parameter to 0.0 disables the function.	Default: 0.0 min Min.: 0.0 Max.: 3600.0	–
P4-08 (0D01) RUN	Pre-Charge Loss of Prime Level 2	Pre-Charge LOP 2	Detects loss of prime in the pump. When the measured quantity determined by P1-18 drops below this level for the time set in P1-20 and the output frequency is at the level set in P4-06, a “Loss of Prime” condition occurs. The drive responds to the “Loss of Prime” condition depending on the setting of P1-22, Loss of Prime Selection.	Default: 0.0 A <> Min.: 0.0 Max.: 1000.0	–
P4-10 (0D03) RUN	AUTO Mode Operator Run Power Down Storage	AUTO RunPwr Loss 0: Disabled 1: Enabled	Stores the run status in AUTO Mode when operating from the HOA keypad (b1-02 = 0).	Default: 0 Range: 0, 1	238

## B.12 P: Pump Parameters

No. (Addr. Hex)	Name	LCD Display	Description	Values	Page
P4-11 (0D04) 	Thrust Bearing Acceleration Time	Thrust Acc. Time	Sets the time at which the drive output frequency will ramp up to the reference frequency set in P4-12.	Default: 1.0 s Min.: 0.0 Max.: 600.0	–
P4-12 (0D05) 	Thrust Bearing Frequency	Thrust Freq.	The drive will accelerate to this frequency in the time set to P4-11. The drive will decelerate from the frequency in the time set to P4-13.  <b>WARNING! Sudden Movement Hazard. If the drive is powered down while running, it will automatically initiate an internal Run command upon power-up.</b>	Default: 30.0 Hz Min.: 0.0 Max.: [E1-04]	239
P4-13 (0D06) 	Thrust Bearing Deceleration Time	Thrust Dec Time	Sets the amount of time it takes to bring the drive from the Thrust Frequency set in P4-12 to stop when Thrust Mode is active. When the Run command is removed while the drive is operating in Thrust Mode above the Thrust Frequency, the time set in this parameter is used when the frequency reference is at or below the thrust frequency.	Default: 5.0 s Min.: 0.0 Max.: 600.0	–
P4-14 (0D07) <6>	Two Motor Alternation Selection	2Motor Alternate 0: Disabled 1: Enabled 2: Motor 1 Only 3: Motor 2 Only	Enables and disables the alternation feature 0: Disable 1: Enable 2: Motor 1 Only 3: Motor 2 Only	Default: 0 Range: 0 to 3	–
P4-15 (0D08) <6>	Two Motor Alternation Operation Selection	2Motor Alt Oper 0: Wait For Stop 1: Immediate	Determines drive behavior when the internal alternation timer expires. 0: Wait For Stop 1: Immediate (Auto mode only)	Default: 0 Range: 0, 1	–
P4-16 (0D09) <6>	Two Motor Alternation Time	2Motor Alt Time	Sets the amount of time each motor will run before the drive switches to the other motor.	Default: 24.0 H Min.: 0.1 Max.: 100.0	–
P4-17 (0D0A) 	Utility Start Delay	Utility Delay	Sets the amount of time that the drive will delay starting if a Run command is present at power-up. When P1-01, Pump Mode, is set to 3 (MEMOBUS network), the drive is unavailable to the network (Pump Off Network) when the function is active. Setting this parameter to 0.0 disables the function.	Default: 0.2 min Min.: 0.0 Max.: 1000.0	239
P4-18 (0D0B) 	Differential Level	Differential Lvl	Sets the maximum difference allowed between the PID Feedback and the Differential Feedback. The drive will respond based on the setting in P4-20 when the difference exceeds the value set in this parameter for the time set in P4-19.	Default: 10.0 PSI </> Min.: 0.0 Max.: 6000.0	–
P4-19 (0D0C) 	Differential Level Detection Time	Diff Lvl DetTime	Sets the amount of time that the difference between PID Feedback and the Differential Feedback must exceed the P4-18 value before responding based on the P4-20 value.	Default: 10 sec Min.: 0 Max.: 3600	–
P4-20 (0D0D) <6>	Differential Level Detection Selection	Diff Lvl Det Sel 0: Fault 1: Alarm 2: Digital Output	Determines drive response during a “Differential Detected” condition. 0: Fault (and Digital Out) 1: Alarm (and Digital Out) 2: Digital Out Only	Default: 0 Range: 0 to 2	–
P4-21 (0D0E)	Low City Input Select	Low City In Sel 0: Normally Open 1: Normally Closed	Selects the type of pressure switch connected to the “Low City Press” digital input (H1-0□ = 73). 0: Normally open (closed indicates the Low City Pressure condition) 1: Normally closed (open indicates the Low City Pressure condition)	Default: 1 Range: 0, 1	–
P4-22 (0D0F) 	Low City On-Delay Time	Low City On Dly	Sets the amount of time a Low City Pressure condition needs to be present before the drive will stop.	Default: 10 s Min.: 1 Max.: 1000	–
P4-23 (0D10) 	Low City Off-Delay Time	Low City Off Dly	Sets the amount of time a Low City Pressure condition needs to be absent before the drive will restart.	Default: 5 s Min.: 0 Max.: 1000	–

No. (Addr. Hex)	Name	LCD Display	Description	Values	Page
P4-24 (0D11) RUN	Low City Alarm Text	Low City Alarm Txt 0: Low Cty Pressure 1: Low Suction Pres 2: Low Watr in Tank	Selects the alarm message that will be displayed when a Low City Pressure condition is detected. 0: Low city pressure 1: Low suction pressure 2: Low water in tank	Default: 0 Range: 0 to 2	–
P4-25 (0D12)	Remote Drive Disable Selection	Rem Drv Dis Sel 0: Normally Open 1: Normally Closed	Selects the type of pressure switch connected to the “Remote Drive Disable” digital input (H1-0□ = 95). 0: Normally open (closed indicates the Remote Drive Disable condition) 1: Normally closed (open indicates the Remote Drive Disable condition)	Default: 1 Range: 0, 1	–
P4-26 (0D13) RUN	Remote Drive Disable On-Delay	Drv Dis On-Delay	Sets the amount of time a Remote Drive Disable condition must be present before the drive will stop.	Default: 0 s Min.: 0 Max.: 1000	–
P4-27 (0D14) RUN	Remote Drive Disable Off-Delay	Drv Dis OffDelay	Sets the amount of time a Remote Drive Disable condition must be absent before the drive will run.	Default: 0 s Min.: 0 Max.: 1000	–
P4-29 (0D16) RUN <4>	Lube Pump Message Text	Lube Pump MsgText 0: Lube Pump 1: DigitalOut Delay 2: Primer Pump 3: SreenMtrStarter	Selects which text is displayed when Lube Pump is active. Also changes the text for the Lube Pump Digital Output selection (H2-□□ = 8B) 0: Lube Pump 1: Digital Out Delay 2: Primer Pump <6> 3: Screen Motor Starter <6>	Default: 0 Range: 0 to 3	–
P4-30 (0D17) <4>	Lube Pump Active During Run	Lube Pump DurRun 0: Disabled 1: Active DuringRun	When enabled, the Lube Pump digital output stays activated after the timer expires and the drive starts to run normally. The output is deactivated only when the drive stops, faults, or sleeps. 0: Disabled 1: Active During Run	Default: 0 Range: 0, 1	–
P4-31 (0D18) RUN	Lube Pump / Digital Output Delay Timer	Lube Pump Time	Sets the amount of time to delay the drive output and to energize the digital output (H2-□□ = 8B) before the drive is allowed to run. Setting this parameter to 0.0 disables the function.	Default: 0.0 s Min.: 0.0 Max.: 3000.0 <5>	–
P4-32 (0D19) RUN <4>	Pre-charge Level 2	PreCharge Level2	For normal PI operation during Pre-charge 2, if the PI Feedback signal rises above the P4-32 level, Pre-charge 2 is cancelled and the drive resumes normal operation. For inverse PI operation and during Pre-charge 2, if the PI Feedback signal goes below the P4-32 level, Pre-charge 2 is cancelled and the drive resumes normal operation. When set to zero, Pre-charge 2 still runs when P4-07 is set, but uses P4-01 to determine if normal operation should resume.	Default: 0.0 PSI <7> Min.: 0.0 Max.: 6000.0	–
P4-36 (0D1D) RUN <6>	Pressure Reached Exit Conditions	Pressure Reached &Hyst Above &Below 1: Hysteresis 1-Way	Determines Selects how the digital output reacts to Feedback changes after it activates. 0: Hysteresis Above and Below 1: Hysteresis One Way	Default: 1 Range: 0, 1	–
P4-37 (0D1E) RUN <6>	Pressure Reached Hysteresis Level	Press Reach Hyst	Sets the hysteresis level for exiting the Pressure Reached condition.	Default: 3.0 PSI <7> Min.: 0.1 Max.: 100.0	–
P4-38 (0D1F) RUN <6>	Pressure Reached On-Delay Time	PressReach OnDly	Sets the delay time that is applied prior to activating the Pressure Reached condition.	Default: 1.0 s Min.: 0.1 Max.: 60.0	–
P4-39 (0D20) RUN <6>	Pressure Reached Off-Delay Time	PressReachOffDly	Sets the delay time that is applied prior to deactivating the Pressure Reached condition.	Default: 1.0 s Min.: 0.1 Max.: 60.0	–
P4-40 (0D21) RUN <6>	Pressure Reached Detection Selection	PressReachDetSel 0: Always 1: Drive Running 2: Run Command	Sets the value that the drive status must match to trigger the Pressure Detection digital output. 0: Always 1: Drive Running 2: Run Command	Default: 0 Range: 0 to 2	239

<1> Unit is determined by P1-02, System Units, setting.

## B.12 P: Pump Parameters

- <2> Available in drive software versions PRG: 8553 and later. Not available in drive models 4A0930 and 4A1200.
- <3> Unit text is set by P1-18, Prime Loss Detection Method.
- <4> Available in drive software versions PRG: 8551 and later.
- <5> Maximum value is 300.0 in drive software versions PRG: 8553 and earlier.
- <6> Available in drive software versions PRG: 8552 and later. Not available in drive models 4A0930 and 4A1200.

### ◆ P5: Pump HAND Mode

No. (Addr. Hex)	Name	LCD Display	Description	Values	Page
P5-01 (0D2C) <span style="border: 1px solid black; padding: 1px;">RUN</span>	HAND Mode Ref Source	Hand Mode 1 Src 0: Analog Input 1: Hand Ref 1 (OPR)	Sets the HAND Mode reference. 0: Analog input <b>Note:</b> Analog input is defaulted to input A3 (0-10 V). 1: P5-02 (HAND reference)	Default: 1 Range: 0, 1	–
P5-02 (0D2D) <span style="border: 1px solid black; padding: 1px;">RUN</span>	HAND Reference 1	HAND Reference 1	Sets the frequency reference used when HAND Mode is active and P5-01 is set to 1.	Default: 40.0 Hz Min.: 0 Max.: [E1-04]	240
P5-03 (0D2E)	HAND/AUTO During Run Selection	HAND/AUTO @Run 0: Disabled 1: Enabled	Selects whether the drive will permit switching between HAND and AUTO Modes while running. 0: Disabled 1: Enabled	Default: 0 Range: 0, 1	–
P5-04 (0D2F)	HAND Key Function Selection	Oper HAND Key 0: Disabled 1: Enabled	Enables and disables the HAND key on the HOA keypad. 0: Disabled 1: Enabled	Default: 1 Range: 0, 1	240
P5-05 (0D30) <span style="border: 1px solid black; padding: 1px;">RUN</span>	HAND Reference 2	HAND Reference 2	Sets the frequency reference used when HAND Mode 2 is active.	Default: 0.0 Hz Min.: 0.0 Max.: [E1-04]	–
P5-06 (0D31) <span style="border: 1px solid black; padding: 1px;">RUN</span>	HAND Ref. 1 Loss of Prime Level	HandRef1 LOP Lvl	Detects loss of prime in the pump. When the measured quantity determined by P1-18 drops below this level for the time set in P1-20 and the output frequency is at the level set in P5-02, a “Loss of Prime” condition occurs. The drive responds to the “Loss of Prime” condition depending on the setting of P1-22, Loss of Prime Selection.	Default: 0.0 A </> Min.: 0.0 Max.: 1000.0	–
P5-07 (0D32) <span style="border: 1px solid black; padding: 1px;">RUN</span>	HAND Ref. 2 Loss of Prime Level	HandRef2 LOP Lvl	Detects loss of prime in the pump. When the measured quantity determined by P1-18 drops below this level for the time set in P1-20 and the output frequency is at the level set in P5-05, a “Loss of Prime” condition occurs. The drive responds to the “Loss of Prime” condition depending on the setting of P1-22, Loss of Prime Selection.	Default: 0.0 A </> Min.: 0.0 Max.: 1000.0	–
P5-09 (0D34)	HAND References Set via Motor Operated Pot Selection	Hand MOP Sel 0: Disabled 1: Enabled	Selects whether parameters P5-02 and P5-05 are changed via MOP from the home screen. 0: Disabled 1: Enabled	Default: 0 Range: 0, 1	–

- <1> Unit text is set by P1-18, Prime Loss Detection Method.

◆ P6: Flow Meter Setup

No. (Addr. Hex)	Name	LCD Display	Description	Values	Page
P6-01 (0D5E)	Flow Meter Scaling	Flow Meter Scale	<p>When an analog input is used for the flow rate, this parameter performs the following functions:</p> <ul style="list-style-type: none"> <li>Enables and disables flow meter functions. This parameter must be set to a value greater than 0 to enable flow meter functions.</li> <li>Sets the scaling for the “Flow Rate” analog input.</li> <li>Sets the scaling for the “Flow Rate” analog output.</li> <li>Sets the display scaling when “Flow Rate” is used as the PID feedback.</li> </ul> <p>When an pulse input is used for the flow rate, this parameter performs the following functions:</p> <ul style="list-style-type: none"> <li>Enables and disables flow meter functions. Parameter must be set to a value greater than zero to enable flow meter functions.</li> <li>Sets the scaling for the “Flow Rate” analog output.</li> <li>Sets the display scaling when “Flow Rate” is used as the PID feedback.</li> </ul>	Default: 0.0 GPM Min.: 0.0 Max.: 6000.0	–
P6-02 (0D5F) RUN	Turbine Input Scaling (Coarse)	Turbine Scale 1	Sets the scaling for the turbine in pulses per gallon. Pulses/Gallon = P6-02 + P6-03 This parameter is internally lower-limited to 0.0001 ppG.	Default: 1 ppG Min.: 0 Max.: 6000	–
P6-03 (0D60) RUN	Turbine Input Scaling (Fine)	Turbine Scale 2		Default: 0.0000 ppG Min.: 0.0000 Max.: 0.9999	–
P6-04 (0D61)	Water Flow Units	Water Flow Units 0: Gal/Min (GPM) 1: Gal/Hr (GPH) 2: Ft3/Min (CFM) 3: M3/Hr (CMH) 4: Acre-Ft/Yr (AFY)	Sets the display units for monitor U1-83, P2-02, P6-06, P6-17, P9-41, and P9-42. 0: U.S. Gallons / min (GPM) 1: U.S. Gallons / hr (GPH) 2: Cubic Feet / min (CFM) 3: Cubic Meters / hr (CMH) 4: Acre-Feet / yr (AFY)	Default: 0 Range: 0 to 4	–
P6-05 (0D62) RUN	Flow Accumulation Reset	Flow Accum Reset	Resets the accumulated flow and returns monitors U1-96 and U1-97 to 0. 0: No reset 7770: Reset accumulation 8880: Set Accumulation (P6-31 to P6-34) All other settings have no effect.  <b>Note:</b> After this parameter is changed, the setting will automatically return to “0”.	Default: 0 Min.: 0 Max.: 65535	–
P6-06 (0D63) RUN	Low Flow Level	Low Flow Level	Sets the level below which the flow must fall for longer than the time set in P6-07 to trigger a Low Flow condition. Setting this parameter to 0.0 will disable the function.	Default: 0.0 GPM Min.: 0.0 Max.: 6000.0	–
P6-07 (0D64) RUN	Low Flow Detection Delay Time When Already Running	Low Flow Tim Run	Sets the length of time that the flow rate must be below the level set in P6-06 to detect a Low Flow condition.	Default: 10 s Min.: 0 Max.: 6000	–
P6-08 (0D65) RUN	Low Flow Detection Wait Time at Start	Low Flow Time St	Sets the length of time that the drive will wait after coming out of a zero speed condition before activating Low Flow detection.  <b>Note:</b> This feature is canceled when the Flow Rate rises above the Low Flow Level for the time set in P6-21, Low Flow Start Delay Cancel Time.	Default: 0.0 min Min.: 0.0 Max.: 3600.0	–
P6-09 (0D66)	Low Flow Select	Low Flow Sel 0: No Display 1: Alarm Only 2: Fault 3: Restart (P6-10)	Determines drive response when a Low Flow condition is detected. 0: No display 1: Alarm only 2: Fault 3: Auto-restart (time set by P6-10)	Default: 1 Range: 0 to 3	–
P6-10 (0D67)	Low Flow Auto-Restart Time	LowFlow Restart	Set the length of time that the drive will wait before attempting an auto-restart of the Low Flow fault. This parameter is effective only when P6-09 is set to 3.	Default: 3.0 min Min.: 0.1 Max.: 6000.0	–

## B.12 P: Pump Parameters

No. (Addr. Hex)	Name	LCD Display	Description	Values	Page
P6-11 (0D68) <input type="checkbox"/> RUN	Accumulation Level - Millions	AccumLvl*1000000	Sets the accumulated volume that will trigger the Accum Level alarm, Accum Level fault, or the Accum Level digital output. Accum Level is calculated using the following formula: Level = (P6-11 * 1000000) + (P6-12 * 1000) + P6-13 + P6-14)	Default: 0 gal <> Min.: 0 Max.: 65535	-
P6-12 (0D69) <input type="checkbox"/> RUN	Accumulation Level - Thousands	AccumLvl*1000		Default: 0 gal <> Min.: 0 Max.: 999	240
P6-13 (0D6A) <input type="checkbox"/> RUN	Accumulation Level - Ones	AccumLvl*1		Default: 0 gal <> Min.: 0 Max.: 999	-
P6-14 (0D6B) <input type="checkbox"/> RUN	Accumulation Level - Decimal	AccumLvl*0.0001		Default: 0.0000 gal <> Min.: 0.0000 Max.: 0.9999	-
P6-15 (0D6C) <input type="checkbox"/> RUN	Accumulation Behavior	Accum Behavior 0: No Display 1: Alarm Only 2: Fault 3: Fault-ResetAccum 4: Stop & Alarm 5: Stp/Alm/RstAccum	Determines drive response when the accumulated volume reaches the P6-11 to P6-14 level. 0: No display 1: Alarm only 2: Fault 3: Fault - Auto flow accum reset 4: Stop and alarm 5: Stop, alarm, and reset flow accumulation	Default: 1 Range: 0 to 5	240
P6-16 (0D6D)	Flow Meter Accumulator Units Select	Accum Units 1: Gallons (gal) 2: Acre-Foot (A-F)	Selects whether the drive accumulates flow in gallons or acre-feet. 1: Gallons (gal) 2: Acre-feet <b>Note:</b> Changing this parameter resets the accumulated flow (U1-84 to U1-87) to zero.	Default: 1 Range: 1, 2	-
P6-17 (0D6E) <input type="checkbox"/> RUN	High Flow Level	High Flow Level	Sets the level above which the flow must rise for the time set in P6-18 to trigger a High Flow condition.	Default: 0.0 GPM < > <> Min.: 0.0 Max.: 6000.0	240
P6-18 (0D6F) <input type="checkbox"/> RUN	High Flow Detection Delay Time	High Flow Time	Sets the length of time that the flow rate must be above the level set in P6-17 to detect a High Flow condition.	Default: 10 s Min.: 0 Max.: 6000	-
P6-19 (0D70)	High Flow Select	High Flow Sel 0: No Display 1: Alarm Only 2: Fault 3: Restart (L5-04)	Sets drive behavior when a High Flow condition is detected. 0: No display 1: Alarm only 2: Fault 3: Auto-restart (time set by L5-04)	Default: 1 Range: 0 to 3	240
P6-20 (0D71) <>	Accumulator Stopping Method Selection	Accum Stop Sel 0: Ramp to Stop 1: Coast to Stop 2: Fast-Stop	Selects how the drive stops when the Flow Accumulator has reached its target level (P6-11 to P6-14). Effective only when P6-15 (Accum Behavior) is set for Fault or Stop (selections 2 to 5).	Default: 1 Range: 0 to 2	-
P6-21 (0D72) <input type="checkbox"/> RUN <>	Low Flow Detection Delay @ Start Cancel Time	LoFloStartDlyOff	Sets the amount of time that the flow rate must rise above the Low Flow Level (P6-06) to cancel the Low Flow Detection Delay Time at Start (P6-08) and activate Low Flow Detection.	Default: 5 s Min.: 0 Max.: 6000	-
P6-22 (0D73) <>	Flow Meter Decimal Place Position	Flow Meter DecPt 0: No Dec (XXXXX) 1: 1 Dec (XXXX.X) 2: 2 Dec (XXX.XX)	Sets the number of decimal places for the Flow Meter parameters and monitor: 0: No Dec (XXXXX) 1: 1 Dec (XXXX.X) 2: 2 Dec (XXX.XX)	Default: 1 Range: 0 to 2	-
P6-25 (0D76) <>	Flow Rate Limit Foldback Message Style	Flow Lim Msg 0: Full Screen Msg 1: Home Mon Text	Selects how the "Flow Rate Limit Foldback" message is displayed on the operator. 0: Full Screen Message 1: Home Monitor Text	Default: 0 Range: 0, 1	241

No. (Addr. Hex)	Name	LCD Display	Description	Values	Page
P6-26 (0D77) <5>	Flow Limit Selection	Flow Limit Sel 0: Disabled 1: Enabled 2: Enabled – Low Limit	Enables and disables the Flow Rate Limiter. 0: Disabled 1: Enabled 2: Enabled – Low Limit	Default: 0 Range: 0 to 2	–
P6-27 (0D78) RUN <5>	Flow Limit Level	Flow Limit Level	Sets the Flow Rate Limit. When P6-26 = 1, the drive reduces speed when the Flow Rate increases rapidly or exceeds this level (PI control). When P6-26 = 2, the drive reduces speed when the Flow Rate decreases rapidly or goes below this level (PI control).	Default: 0.0 GPM <1> <4> Min.: 0.0 Max.: 6000.0	–
P6-28 (0D79) RUN <5>	Flow Limit Regulator Gain	Flow Limit Gain	Sets the responsiveness of the Flow Rate limit regulator. Increasing the setting increases the responsiveness.	Default: 1.00 Min.: 0.00 Max.: 25.00	–
P6-29 (0D7A) RUN <5>	Flow Limit Regulator Integral Time	Flow Lim I Time	Sets the responsiveness of the Flow Rate limit regulator. Reducing the setting increases the responsiveness.	Default: 1.00 s Min.: 0.00 Max.: 10.00	–
P6-30 (0D7B) RUN <5>	Flow Limit Regulator Delay @ Start	FlowLimStartDly	Sets the amount of time Flow Rate Limiter activates after the drive has run for the amount of time set.	Default: 10 s Min.: 0 Max.: 6000	–
P6-31 (0D7C) RUN <3>	Set Accumulation Level - Millions	SetAccumLvl*10000 00	Parameters P6-31 to P6-34 set the stored accumulated volume. Level = (P6-31 * 1000000) + (P6-32 * 1000) + P6-33 + P6-34. Value is accepted when P6-05 = 8880, after which it resets to 0.	Default: 0 <2> Min.: 0 Max.: 65535	–
P6-32 (0D7D) RUN <3>	Set Accumulation Level - Thousands	SetAccumLvl * 1000		Default: 0 <2> Min.: 0 Max.: 999	–
P6-33 (0D7E) RUN <3>	Set Accumulation Level - Ones	SetAccumLvl * 1		Default: 0 <2> Min.: 0 Max.: 999	–
P6-34 (0D7F) RUN <3>	Set Accumulation Level - Decimal	SetAccumLvl *0.0001		Default: 0.0000 <2> Min.: 0.0000 Max.: 0.9999	–
P6-35 (0D80) RUN <5>	Accumulator Delta Save Selection	Accum Delta Save 0: - - 1: Set 2: Reset	Sets and resets the starting value used to calculate the Accumulation Delta monitor U1-89. 0: - - 1: Set 2: Reset  <b>Note:</b> This parameter returns to 0 after the selected action is performed.	Default: 0 Range: 0 to 2	–

## B.12 P: Pump Parameters

No. (Addr. Hex)	Name	LCD Display	Description	Values	Page
P6-36 (0D81) <input type="checkbox"/> RUN <>	Delta Starting Accumulation Level - Millions	DeltaVol*1000000	Parameters P6-36 to P6-39 set the starting values used for the Accumulation Delta monitor U1-89. Level = (P6-36 * 1000000) + (P6-37 * 1000) + P6-38 + P6-39. Setting P6-35 to 1 will overwrite the values by the current accumulation values as displayed by U1-84 to U1-87 (or U1-88). Setting P6-35 to 2 resets all values to 0.	Default: 0 gal <> Min.: 0 Max.: 65535	-
P6-37 (0D82) <input type="checkbox"/> RUN <>	Delta Starting Accumulation Level - Thousands	DeltaVol * 1000		Default: 0 gal <> Min.: 0 Max.: 999	-
P6-38 (0D83) <input type="checkbox"/> RUN <>	Delta Starting Accumulation Level - Ones	DeltaVol * 1		Default: 0 gal <> Min.: 0 Max.: 999	-
P6-39 (0D84) <input type="checkbox"/> RUN <>	Delta Starting Accumulation Level - Decimal	DeltaVol *0.0001		Default: 0.0000 gal <> Min.: 0.0000 Max.: 0.9999	-

<1> Unit text is set by P6-04, Water Flow Units.

<2> Unit text is set by P6-16, Flow Meter Accumulator Units Select.

<3> Available in drive software versions PRG: 8551 and later.

<4> Resolution is set by P6-22, Flow Meter Decimal Place Position.

<5> Available in drive software versions PRG: 8552 and later. Not available in drive models 4A0930 and 4A1200.

<6> Available in drive software versions PRG: 8553 and later. Not available in drive models 4A0930 and 4A1200.

## ◆ P7: Anti-Jam

No. (Addr. Hex)	Name	LCD Display	Description	Values	Page
P7-01 (0D90)	Anti-Jam Operation Selection	Anti-Jam Sel 0: Disabled 1: Enabled	Enables and disables the anti-jam function. 0: Disabled 1: Enabled	Default: 0 Range: 0, 1	-
P7-02 (0D91) <input type="checkbox"/> RUN	Anti-Jam Cycle Count	AJ Cycle Count	Sets the maximum number of cycles that will be attempted before triggering and Anti-Jam fault.	Default: 1 Min.: 1 Max.: 100	-
P7-03 (0D92) <input type="checkbox"/> RUN	Anti-Jam Detection Current Level	AJ Det I @Start	Sets the current level at start that will trigger the anti-jam function. Set as a percentage of the motor rated current.	Default: 120% Min.: 50 Max.: 200	-
P7-04 (0D93) <input type="checkbox"/> RUN	Anti-Jam Detection Time at Start	AJ Det Tm@Start	Sets the length of time that current must rise above the level set in P7-03 to trigger the anti-jam function.	Default: 0.3 s Min.: 0.1 Max.: 2.0	-
P7-05 (0D94) <input type="checkbox"/> RUN	Anti-Jam During Run Current	AJ Det I @Run	Sets the current level during run that will trigger the anti-jam function. Set as a percentage of motor rated current. Setting this parameter to 0 will disable anti-jam during run.	Default: 0% Min.: 0 Max.: 200	-
P7-06 (0D95) <input type="checkbox"/> RUN	Anti-Jam During Run Time	AJ Det Tm @Run	Sets the length of time that the current must rise above the level set in P7-05 to trigger the anti-jam function. Restricted to simplex only.	Default: 0.3 s Min.: 0.1 Max.: 2.0	-
P7-07 (0D96) <input type="checkbox"/> RUN	Anti-Jam Frequency Reference	AJ Freq Ref	Sets the maximum speed allowed when the anti-jam function is active.	Default: 25.00 Hz Min.: 0.00 Max.: 400.00	-
P7-08 (0D98) <input type="checkbox"/> RUN	Anti-Jam Release Time	AJ Release Time	Sets the length of time that the current must fall below the level set in P7-03 to resume normal operation.	Default: 2.0 s Min.: 0.5 Max.: 10.0	-



## ◆ P8: De-Scale / De-Ragging

No. (Addr. Hex)	Name	LCD Display	Description	Values	Page
P8-01 (0DB0) <I>	De-scale Operation Selection	De-scale Sel	Selects de-scale functionality. 0: Disabled 1: De-scale Enabled 2: Force De-scale	Default: 0 Range: 0 to 2	–
P8-02 (0DB1) RUN <I>	De-scale Cycle Count	De-scale Cycles	Sets the maximum number of cycles attempted before the Anti-Jam fault occurs. Also sets the number of fwd/rev cycles for the De-scale function.	Default: 1 Min.: 1 Max.: 100	–
P8-03 (0DB2) RUN <I>	De-scale Frequency Reference	De-scale FreqRef	Sets the speed during the de-scale operation.	Default: 25.00 Hz Min.: 0.00 Max.: 400.00	–
P8-04 (0DB3) RUN <I>	De-scale Forward Run Time	De-scale FWD Run	Sets the amount of time the drive will run in the forward direction each cycle during the de-scale function.	Default: 10 s Min.: 1 Max.: 6000	–
P8-05 (0DB4) RUN <I>	De-scale Reverse Run Time	De-scale REV Run	Sets the amount of time the drive will run in the reverse direction each cycle during the de-scale function.	Default: 10 s Min.: 1 Max.: 6000	–
P8-06 (0DB5) RUN <I>	De-scale Acceleration Time	De-scale Accel	Sets the amount of time it will take the drive to accelerate from zero to the De-scale frequency reference P8-03.	Default: 2.0 s Min.: 0.0 Max.: 600.0	–
P8-07 (0DB6) RUN <I>	De-scale Deceleration Time	De-scale Decel	Sets the amount of time it will take the drive to decelerate from the De-scale frequency reference P8-03 to zero.	Default: 2.0 s Min.: 0.0 Max.: 600.0	–
P8-08 (0DB7) RUN <I>	De-scale Pump Run Time	De-Scale Time	Sets the number of pump operating hours (pump speed > 0) before a de-scale routine will run.	Default: 168.0 H Min.: 0.1 Max.: 2000.0	–

<I> Available in drive software versions PRG: 8551 and later.

## B.12 P: Pump Parameters

### ◆ P9: Network Options

Parameters in this group are functional only when P1-01, Pump Mode, is set to 3 (MEMOBUS network).

No. (Addr. Hex)	Name	LCD Display	Description	Values	Page
P9-01 (0DF4)	Lead Drive Selection	Lead Drive Sel 0: Next Available 1: Lowest Runtime 2: Stop History	Specifies how the next lead drive is selected. 0: Next available 1: Lowest runtime 2: Stop history	Default: 1 Range: 0 to 2	–
P9-02 (0DF5)	Feedback Source	Feedback Source 0: Analog only 1: Ana->Net, No Alrm 2: Ana->Net, Alarm 3: Network only	Defines which signal to use for PI feedback when P1-01, Pump Mode, is set to 3 (MEMOBUS network). 0: Analog only 1: Ana->Net, No Alrm 2: Ana->Net, Alarm 3: Network only	Default: 0 Range: 0 to 3	–
P9-03 (0DF6) <input type="checkbox"/> RUN	Alternation Time	Alternation Time	Specifies the time for a drive to request alternation. Setting this parameter to 0 disables the function.	Default: 24 H Min.: 0 Max.: 1000	–
P9-04 (0DF7)	Alternation Mode	Alternation Mode 0: FIFO Auto 1: FIFO Forced 2: LIFO 3: FIFO @ Sleep	Determines how alternation is performed. 0: FIFO auto 1: FIFO forced 2: LIFO 3: FIFO @sleep	Default: 0 Range: 0 to 3	–
P9-05 (0DF8)	Lag Drive Mode	Lag Drive Mode 0: Fixed Speed 2: Turn Off 3: Follow Lead Spd	Determines the functionality of the lag drives. 0: Fixed speed. The drive runs at the P9-06 setting after the time set in P9-07 expires. 2: Turn off. The drive stops running when it switches to a lag drive after the time set in P9-07 expires. 3: Follow Lead Speed. The drive will follow the speed of the current lead drive, applying P9-30 gain and P9-31 bias.	Default: 0 Range: 0, 2, 3	–
P9-06 (0DF9) <input type="checkbox"/> RUN	Lag Fixed Speed	Lag Fixed Speed	Sets the speed at which the drive will run when the drive changes from a lead to a lag and the time set in P9-07 has expired.	Default: 55.0 Hz Min.: 0.0 Max.: 400.0	–
P9-07 (0DFA) <input type="checkbox"/> RUN	Lag Fixed Speed Delay	Lag Fix Spd Dly	Specifies how long speed is latched before performing the function specified in P9-05 when the drive changes from a lead to a lag.	Default: 5 s Min.: 0 Max.: 1000	–
P9-08 (0DFB)	Add Pump Mode	Add Pump Mode 0: Output Frequency 1: Feedback 2: Feedback + Fout 3: Flow Meter	Selects the detection method for staging a new pump. 0: Output frequency 1: Feedback 2: Feedback + Fout 3: Flow meter	Default: 0 Range: 0 to 3	–
P9-09 (0DFC) <input type="checkbox"/> RUN	Add Frequency Level	Add Freq Lvl	When P9-08 is set to 0, this parameter sets the level above which the output frequency needs to rise for the time set in P9-11 before the lead drive will send a request for a new lead drive via the iQPump MEMOBUS network. When P9-08 is set to 2 and the delta feedback (setpoint minus feedback) has exceeded the level set in P9-10 for the time set in P9-11, this parameter sets the level above which the output frequency needs to rise before the lead drive will send a request for a new lead drive via the iQPump MEMOBUS network.	Default: 59.5 Hz Min.: 0.0 Max.: 400.0	–
P9-10 (0DFD) <input type="checkbox"/> RUN	Add Delta Level	Add Delta Lvl	When P9-08 is set to 1, this parameter sets the level above which the delta feedback (setpoint minus feedback) must rise for the time set in P9-11 before the lead drive will send a request for a new lead drive via the iQPump MEMOBUS network. When P9-08 is set to 2 and the output frequency has exceeded the level set in P9-09 for the time set in P9-11, this parameter sets the level above which the delta feedback (setpoint minus feedback) needs to rise before the lead drive will send a request for a new lead drive via the iQPump MEMOBUS network.	Default: 4.0 PSI </> Min.: 0.0 Max.: 6000.0	–
P9-11 (0DFE) <input type="checkbox"/> RUN	Add Delay Time	Add Dly Time	Sets the delay time before a new lead drive is added to the system.	Default: 10 s Min.: 0 Max.: 3600	–

No. (Addr. Hex)	Name	LCD Display	Description	Values	Page
P9-12 (0DFE)	Remove Pump Mode	Remove Pump Mode 0: Output Frequency 1: Feedback 2: Feedback + Fout 3: Flow Meter	Sets the detection method for de-staging to the previous lead pump. 0: Output frequency 1: Feedback 2: Feedback + Fout 3: Flow meter	Default: 0 Range: 0 to 3	-
P9-13 (0E00) [RUN]	Remove Frequency Level	Remove Freq Lvl	When P9-12 is set to 0, this parameter sets the level below which the output frequency must fall for the time set in P9-15 before the lead drive will send a request to be removed from the system via the iQPump MEMOBUS network. When P9-12 is set to 2 and the delta feedback (feedback minus setpoint) has exceeded the level set in P9-14 for the time set in P9-15, this parameter sets the level below which the output frequency must fall before the lead drive will request to be removed from the system via the iQPump MEMOBUS network.	Default: 40.0 Hz Min.: 0.0 Max.: 400.0	-
P9-14 (0E01) [RUN]	Remove Delta Level	Remove Delta Lvl	When P9-12 is set to 1, this parameter sets the level above which the delta feedback (feedback minus setpoint) must rise for the time set in P9-15 before the lead drive will request to be removed from the system via the iQPump MEMOBUS network. When P9-12 is set to 2 and the output frequency has exceeded the level set in P9-13 for the time set in P9-15, this parameter sets the level above which the delta feedback (feedback minus setpoint) frequency must rise before the lead drive will request to be removed from the system via the iQPump MEMOBUS network.	Default: 0.0 PSI </> Min.: 0.0 Max.: 6000.0	-
P9-15 (0E02) [RUN]	Remove Delay Time	Remove Dly Time	Sets the delay time before the lead drive is removed from the system.	Default: 10 s Min.: 0 Max.: 3600	-
P9-16 (0E03) [RUN]	Stabilization Time	Stabilize Time	Sets the time used to stabilize the system when a pump is staged or de-staged. Lead/lag control and pump protection are suspended during this time.	Default: 3 s Min.: 0 Max.: 3600	-
P9-17 (0E04) [RUN]	Setpoint Modifier	Set-pt Modifier	Sets the value by which the system setpoint is incremented depending on the number of pumps that are running. Pump 1: Setpoint Pump 2: Setpoint + ((X-1) (P9-17))	Default: 0.0 PSI </> Min.: -999.9 Max.: 999.9	-
P9-18 (0E05) [RUN]	High Feedback Quick De-Stage	High FB De-stage	Sets the feedback level that will trigger a quick de-stage. Set as a percentage of the P1-09 value. The quick de-stage ignores parameters P9-12 to P9-15 and uses an internal 2 second delay. Setting this parameter to 0.0 disables the feature.	Default: 97.0% Min.: 0.0 Max.: 100.0	-
P9-19 (0E06) [RUN]	Alternation Unit	Alternation Unit 0: Hours (H) 1: Minutes (min)	Sets the units used in P9-03. 0: Hours (H) 1: Minutes (min)	Default: 0 Range: 0, 1	-
P9-20 (0E07)	Allow Network Run	Allow Net Run 0: Always 1: First/Altrnation 2: First Only 3: Alternation Only	Specifies when a network Run command is allowed. 0: Always 1: First/alternation 2: First only 3: Alternation only	Default: 0 Range: 0 to 3	-
P9-21 (0E08) [RUN]	Run Priority	Run Priority	Sets the lead drive selection priority overriding the P9-01 selection. If multiple drives have the lowest P9-21 value, then P9-01 determines which drive becomes the lead.	Default: 8 Min.: 1 Max.: 16	-
P9-22 (0E09) [RUN]	System Fault Retry	System Flt Retry	Sets the number of times that the iQPump MEMOBUS network will allow automatic restarts of system faults. The drive uses L5-04, Fault Reset Interval Time, to determine when to attempt a system fault restart. Set this parameter to the same value for all drives on the network.	Default: 5 Min.: 0 Max.: 10	-
P9-23 (0E0A)	Maximum Number of Running Pumps	MaxPumps Running	Sets the maximum number of pumps that can run on the system.	Default: 8 Min.: 1 Max.: 8	-
P9-24 (0E0B) [RUN]	Lead Swap at Sleep	Lead Swap @Sleep	Sets the length of time for which the lead drive will be in Sleep Mode before this drive will request a swap when there is another drive available with a lower P9-21 setting. Setting this parameter to 0 will disable the function.	Default: 0 s Min.: 0 Max.: 7200	-

## B.12 P: Pump Parameters

No. (Addr. Hex)	Name	LCD Display	Description	Values	Page
P9-25 (0E0C)	Highest Node Address	Highest Node Adr	Sets the highest possible node address in the MEMOBUS network. For optimal network performance, set the serial communication address H5-01 beginning with 01h consecutively up to the last drive and then set this parameter to that H5-01 address.	Default: 8 Min.: 2 Max.: 8	–
P9-26 (0E0D)	Master Time-out	Master Time-out	Sets the minimum amount of time that the slave drives will wait for a message from the master before performing the action set in P9-27.	Default: 4.0 s Min.: 1.0 Max.: 10.0	–
P9-27 (0E0E)	Network Recovery	Network Recovery 0: Automatic 1: Slave/Resume 2: Slave/Stop 3: Fault MSL	Determines the drive response when no messages are received from the master for the time set in P9-26. 0: Automatic. The drive will attempt to assume master functionality. 1: Slave/Resume. The drive will continue running when the master is lost and will wait for a master to come online. 2: Slave/Stop. The drive will stop running when the master is lost and will wait for a master to come online. 3: Fault MSL. Fault the drive with an MSL (Master Lost).	Default: 0 Range: 0 to 3	–
P9-28 (0E0F)	NETSCAN Alarm Time	NETSCAN AlrmTime	Sets the amount of time that the slave drives will wait for a message from the master before displaying a NETSCAN alarm.	Default: 2.0 s Min.: 1.0 Max.: 10.0	–
P9-29 (0E10) [RUN]	Net Start Delay	Net Start Delay	Sets the amount of time that the network will wait before selecting and starting the lead drive after the first drive on the network has been put on AUTO Mode.	Default: 2.0 s Min.: 0.0 Max.: 60.0	–
P9-30 (0E11) [RUN]	Lag Drive Speed Follower Gain	Lag Followr Gain	Sets the gain to be applied to the speed of the current lead drive when P9-05 is set to 3. The bias to be applied is set in P9-31.	Default: 100.0% Min.: 0.0 Max.: 300.0	–
P9-31 (0E12) [RUN]	Lag Drive Speed Follower Bias	Lag Followr Bias	Sets the bias to be applied to the speed of the current lead drive when P9-05 is set to 3. The gain to be applied is set in P9-30.	Default: 0.00 Hz Min.: -60.0 Max.: 60.0	–
P9-32 (0E13) [RUN]	Lag Follower Deceleration Time	Lag Followr Dcel	Sets the deceleration time when the P9-33 timer is running and the drive is running as Lag Drive Speed Follower (P9-05 is set to 3).	Default: 60.0 s Min.: 0.0 Max.: 1000.0	–
P9-33 (0E14) [RUN]	Lag Follower Deceleration Time Active Time	Lag Followr Dtim	Sets the time during which the deceleration time set in P9-32 is effective. The drive will use the standard deceleration rate when it expires. Setting this parameter to 0.0 disables the function.	Default: 0.0 s Min.: 0.0 Max.: 360.0	–
P9-34 (0E15) [RUN]	Low Feedback Quick De-Stage	Low FB De-stage	Sets the low feedback level that will trigger a quick de-stage. The quick de-stage ignores parameters P9-12 and P9-15 and only uses an internal 2 second delay. Setting this parameter to 0.0 disables the function.	Default: 0.0 PSI </?> Min.: 0.0 Max.: 6000.0	–
P9-35 (0E16) [RUN] <?>	Alternation Stabilization Time	AltStabilizeTime	Sets the maximum amount of time the drive will stay running when it was called to alternate-out. The drive is put into the Alternation Stabilization Mode during this period. Setting this parameter to 0 disables the function.	Default: 10 s <?> Min.: 0 Max.: 1000	–
P9-36 (0E17) [RUN] <?>	Alternation Stabilization Bias	AltStabilizeBias	Sets the minimum amount of PID error applied to the drive during Alternation Stabilization Mode. A lower value can cause it to remain running longer, while a higher value will make the transition faster at the cost of a more significant pressure change. Set as a percentage of P1-03, System Unit Scaling.	Default: 0.50% Min.: 0.00 Max.: 10.00	–
P9-40 (0E1B) [RUN]	Flow Rate Source	Flow Rate Source 0: Analog Only 3: Network Only	Defines the flow meter input source when P1-01, Pump Mode, is set to 3 (MEMOBUS network). 0: Analog 3: Network	Default: 0 Range: 0, 3	–
P9-41 (0E1C) [RUN]	Add Flow Level	Add Flow Lvl	When P9-08 is set to 3 and the flow rate rises above this level multiplied by the number of pumps running for the time set in P9-11, the lead drive will request for a new lead drive through the iQpump MEMOBUS network.	Default: 0.0 GPM <?> Min.: 0.0 Max.: 6000.0	–
P9-42 (0E1D) [RUN]	Remove Flow Level	Remove Flow Lvl	When P9-12 is set to 3 and the flow rate falls below this level multiplied by the number of pumps running - 1 for the time set in P9-15, the lead drive will request to be removed from the system through the iQpump MEMOBUS network.	Default: 0.0 GPM <?> Min.: 0.0 Max.: 6000.0	–

No. (Addr. Hex)	Name	LCD Display	Description	Values	Page
P9-50 (0E25)	Water Level/Suction Pressure Source	WL/SP/PI-Aux Src 0: Analog only 1: Ana->Net, No Alrm 2: Ana->Net, Alarm 3: Network only	Sets the signal to use for Water Level Control (Q4-□□), Suction Pressure Control (Q5-□□), or PI Aux Control (Q6-□□) when P1-01, Pump Mode, is set to 3 (MEMOBUS network). 0: Analog only 1: Ana->Net, No Alrm 2: Ana->Net, Alarm 3: Network only	Default: 0 Range: 0 to 3	–
P9-51 (0E26)	Low Water Level/Suction Pressure Turn-Off Method	Low WL/SP/PI-Aux 0: Continue Running 1: Turn-off	Determines whether drives will respond to Water Level, Suction Pressure, or PI Aux Control transducer feedback over the MEMOBUS network. 0: Continue Running 1: Turn off	Default: 0 Range: 0, 1	–
P9-60 (0E2F)	Geothermal Temperature Source	Geo Temp Source 0: Analog only 1: Ana->Net, No Alrm 2: Ana->Net, Alarm 3: Network only	0: Analog only 1: Ana->Net, No Alrm 2: Ana->Net, Alarm 3: Network only	Default: 0 Range: 0 to 3	–
P9-98 (0E55) <4>	Network Parameter Push Selection	NetParameterPush 0: Disabled 1: Enabled/Prompt	Selects how system-wide parameters are pushed to the MEMOBUS/Modbus Multiplex network. 0: Disabled 1: Enabled/Prompt	Default: 1 <6> Range: 0, 1	–
P9-99 (0E56)	Network Compatibility Selection	Network Comp Sel 0: A-Ver: 30034 1: B-Ver: 30035/36 2: iQ SmartNetwork	Determines the communication compatibility for the iQPump MEMOBUS network. 0: A-Ver: 30034 1: B-Ver: 30035/36 2: iQ SmartNetwork	Default: 2 Range: 0 to 2	–

- <1> Unit is determined by P1-02, System Units, setting.
- <2> Default is 0 s in drive software versions PRG: 8553 and earlier.
- <3> Available in drive software versions PRG: 8551 and later.
- <4> Available in drive software versions PRG: 8552 and later. Not available in drive models 4A0930 and 4A1200.
- <5> Resolution is set by P6-22, Flow Meter Decimal Place Position.
- <6> Default is 0 in drive software versions PRG: 8553 and earlier.

## B.13 Q: PID Controller Parameters

### ◆ Q1: Preset Setpoint

No. (Addr. Hex)	Name	LCD Display	Description	Values	Page
Q1-01 (0E58) <input type="checkbox"/> RUN	PID Controller Setpoint 1	Setpoint 1	Sets the PID Setpoint when b1-01 is set to 0.	Default: 0.0 Min.: 0.0 Max.: 6000.0 </>	241
Q1-02 (0E59) <input type="checkbox"/> RUN	PID Controller Setpoint 2	Setpoint 2	Sets the PID Setpoint when the "Multi Setpoint 1" or "Alternate Multi Setpoint 1" multi-function digital input is closed.	Default: 0.0 Min.: 0.0 Max.: 6000.0 </>	-
Q1-03 (0E5A) <input type="checkbox"/> RUN	PID Controller Setpoint 3	Setpoint 3	Sets the PID Setpoint when the "Multi Setpoint 2" or "Alternate Multi Setpoint 2" digital input is closed.	Default: 0.0 Min.: 0.0 Max.: 6000.0 </>	-
Q1-04 (0E5B) <input type="checkbox"/> RUN	PID Controller Setpoint 4	Setpoint 4	Sets the PID Setpoint when the "Multi Setpoint 1" and "Multi Setpoint 2" or "Alternate Multi Setpoint 3" multi-function digital inputs are closed.	Default: 0.0 Min.: 0.0 Max.: 6000.0 </>	-
Q1-09 (0E60)	PID Setpoint Set via Motor Operated Pot	Setpoint MOP 0: Disabled 1: Enabled	Selects whether parameters Q1-01 to Q1-04 are changed via MOP from the home screen. 0: Disabled 1: Enabled	Default: 0 Range: 0, 1	-

</> Unit text is set by P1-02, System Units. Scaling is set by P1-03, Feedback Device Scaling.

### ◆ Q2: Geothermal Mode Setup

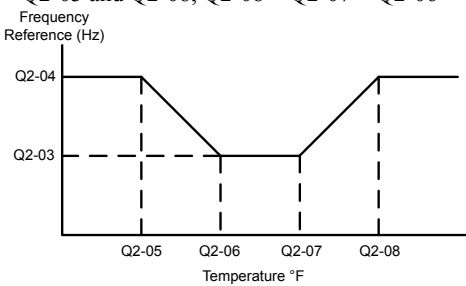
No. (Addr. Hex)	Name	LCD Display	Description	Values	Page
Q2-01 (0E8A)	Minimum Geothermal Temperature Input	MinGeothrm Scale	Sets the temperature that corresponds to a 0 V (or 4 mA) analog input.	Default: 0.0 °F Min.: -110.0 Max.: 320.0	-
Q2-02 (0E8B)	Maximum Geothermal Temperature Input	MaxGeothrm Scale	Sets the temperature that corresponds to a 10 V (or 20 mA) analog input.	Default: 120.0 °F Min.: -110.0 Max.: 320.0	-
Q2-03 (0E8C) <input type="checkbox"/> RUN	Minimum Geothermal Speed	MinGeothrm Speed	Sets the frequency reference characteristics based on the set temperature points and the corresponding frequency. For proper operation, set the parameters as follows: Q2-04 > Q2-03 and Q2-08, Q2-08 > Q2-07 > Q2-06 > Q2-05 	Default: 40.0 Hz Min.: 0.0 Max.: 400.0	-
Q2-04 (0E8D) <input type="checkbox"/> RUN	Maximum Geothermal Speed	MaxGeothrm Speed		Default: 60.0 Hz Min.: 0.0 Max.: 400.0	-
Q2-05 (0E8E) <input type="checkbox"/> RUN	Low Temperature to Run at Maximum Geothermal Speed	Low Temp @ Max		Default: 55.0 °F Min.: -110.0 Max.: 320.0	-
Q2-06 (0E8F) <input type="checkbox"/> RUN	Low Temperature to Run at Minimum Geothermal Speed	Low Temp @ Min		Default: 65.0 °F Min.: -110.0 Max.: 320.0	-
Q2-07 (0E90) <input type="checkbox"/> RUN	High Temperature to Run at Minimum Geothermal Speed	High Temp @ Min		Default: 75.0 °F Min.: -110.0 Max.: 320.0	-
Q2-08 (0E91) <input type="checkbox"/> RUN	High Temperature to Run at Maximum Geothermal Speed	High Temp @ Max		Default: 85.0 °F Min.: -110.0 Max.: 320.0	-

No. (Addr. Hex)	Name	LCD Display	Description	Values	Page
Q2-09 (0E92)	Geothermal Temperature Loss Detection	Geotherm Loss Det 0: Disabled 1: Alarm Only 2: Fault	Selects the drive response when the signal from Terminal A2 falls below 3 mA or rises above 21 mA. This parameter is only effective when H3-0□ = 2 (4 to 20 mA) and H3-0□ = 21 (Geothermal Temperature). 0: Disabled 1: Alarm 2: Fault	Default: 1 Range: 0 to 2	–
Q2-10 (0E93) [RUN]	Geothermal Sleep Delay Time	Geotherm Slp Dly	Set the length of time that the drive must be running at the speed set in Q2-03, Minimum Geothermal Speed, before going to sleep.	Default: 30 s Min.: 0 Max.: 3600	–
Q2-11 (0E94)	Geothermal Temperature Delta Wake Level	Geotherm Wake Lvl	Sets the geothermal temperature that will wake up the drive. The drive will wake up when one of the following conditions is true: Temperature > Q2-07 + Q2-11 OR Temperature < Q2-06 - Q2-11 Setting this parameter to 0.0 will disable Geothermal Sleep Mode.	Default: 0.0 °F Min.: 0.0 Max.: 50.0	–
Q2-12 (0E95) [RUN]	Geothermal Sleep Wake-Up Delay Time	Geotherm Wake Dly	Sets the length of time that the setting of Q2-11, Geothermal Temperature Delta Wake Level, must be met to wake up the drive.	Default: 5 s Min.: 0 Max.: 3600	–

◆ Q3: Output Current Limit

No. (Addr. Hex)	Name	LCD Display	Description	Values	Page
Q3-01 (0EBC)	Output Current Limit Select	Current Lim Sel 0: Disabled 1: Enabled	Enables and disables the output current regulator. 0: Disabled 1: Enabled	Default: 0 Range: 0, 1	–
Q3-02 (0EBD) [RUN]	Current Limit	Current Limit	Sets the current limit. Value is internally limited to 300% of the drive rated current.	Default: 0.0 A Min.: 0.0 Max.: 1000.0	–
Q3-05 (0EC0) <1>	Current Limit Regulator Feedback Filter	Feedback Filter	First order filter time on the feedback used for Current Limit control.	Default: 1000 ms Min.: 5 Max.: 10000	–
Q3-06 (0EC1) <2>	Current Limit Foldback Message Style	Current Lim Msg 0: Full Screen Msg 1: Home Mon Text	Selects how the “Current Limit Foldback” message is displayed on the operator. 0: Full Screen Message 1: Home Monitor Text	Default: 0 Range: 0, 1	241
Q3-10 (0EC5)	Ripple Regulator Selection	1-Phase Foldback 0: Disabled 1: Enabled	Enables and disables the single phase ripple regulator. 0: Disabled 1: Enabled	Default: 1 Range: 0, 1	–
Q3-11 (0EC6)	Ripple Regulator Setpoint	Ripple Reg S.P.	Set as a percentage of the maximum amount of ripple allowed before triggering an input phase loss fault.	Default: 95.0% Min.: 0.0 Max.: 200.0	–
Q3-13 (0EC8) <2>	Single Phase Foldback Message Style	1Ph Foldback Msg 0: Full Screen Msg 1: Home Mon Text	Selects how the “Single Phase Foldback” message is displayed on the operator. 0: Full Screen Message 1: Home Monitor Text	Default: 0 Range: 0, 1	242

<1> Available in drive software versions PRG: 8554 and later. Not available in drive models 4A0930 and 4A1200.

<2> Available in drive software versions PRG: 8553 and later. Not available in drive models 4A0930 and 4A1200.

◆ Q4: Water Level Control

No. (Addr. Hex)	Name	LCD Display	Description	Values	Page
Q4-01 (0EEE) <input type="checkbox"/>	Water Level Selection	Water Level Sel 0: Disabled 1: Enabled	Enables and disables the water level control. 0: Disabled 1: Enabled	Default: 0 Range: 0, 1	–
Q4-02 (0EEF) <input type="checkbox"/>	Water Level Scaling	Water Lvl Scale	Sets the full scale (20 mA) output of the pressure transducer that is connected to the analog input terminal programmed for “WaterLvl/Suction” (H3-□□ = 23). <b>Note:</b> 1 PSI = 2.308 feet of water	Default: 100 PSI Min.: 5 Max.: 500	–
Q4-03 (0EF0) <input type="checkbox"/>	Water Level Setpoint	Water Lvl Setpnt	Sets the amount of water above the sensor to which the drive will attempt to regulate.	Default: 20.0 ft Min.: 0.0 Max.: 1200.0	–
Q4-04 (0EF1) <input type="checkbox"/>	Minimum Water Level	Min Water Level	Sets the level below which the amount of water must drop for the time set in Q4-05 to put the drive to sleep.	Default: 10.0 ft Min.: 0.0 Max.: 1200.0	–
Q4-05 (0EF2) <input type="checkbox"/>	Water Level Sleep Delay Time	WL Sleep Dly Tm	Sets the length of time that the drive will delay after the water level drops below the level set in Q4-04 before going to sleep.	Default: 5 s Min.: 0 Max.: 3600	–
Q4-06 (0EF3) <input type="checkbox"/>	Wake-Up Water Level	Wake-Up Level	Sets the level above which the water needs to rise for more than the time set in Q4-07 for the drive to wake up after being put to sleep via parameter Q4-04, Minimum Water Level.	Default: 30.0 ft Min.: 0.0 Max.: 1200.0	–
Q4-07 (0EF4)	Water Level Control Sleep Wake-Up Time	WL Wake-up Time	Sets the length of time that the water level set in Q4-06 must be met for the drive to wake up after being put to sleep via parameter Q4-04, Minimum Water Level.	Default: 1 s Min.: 0 Max.: 3600	–
Q4-08 (0EF5) <input type="checkbox"/>	Level Control Minimum Speed	Level Min Spd	Sets the minimum speed at which the drive will run when the drive is controlling the water level. When the drive is controlling pressure or if this parameter is set less than P1-06 and P4-12, parameters P1-06 and P4-12 will be used as the minimum speed.	Default: 0.00 Hz Min.: 0.00 Max.: 400.00	–
Q4-09 (0EF6) <input type="checkbox"/>	Low Level Detection Level	Low Level Detect	Sets the level below which the water level must drop for the time set in Q4-10 to trigger the drive response set in Q4-11. Setting this parameter to 0.0 will disable the function. <b>Note:</b> Q4-10 detection time delay is only applicable when Q4-11 = 2 or 3.	Default: 0.0 ft Min.: 0.0 Max.: 1200.0	–
Q4-10 (0EF7) <input type="checkbox"/>	Low Level Detection Time Delay	Low Lvl Det Tm	Sets the length of time that the water level must fall below the level set in Q4-09 to trigger the drive to respond. Applicable when Q4-11 = 2 or 3.	Default: 0.0 <sup>&lt;/&gt;</sup> Min.: 0.0 Max.: 300.0	–
Q4-11 (0EF8)	Low Level Behavior	Low Lvl Behavior 0: No Display 1: Alarm Only 2: Fault 3: Restart (Q4-12)	Selects drive response when the water level drops below the level set in Q4-09 for the time set in Q4-10. 0: No display (digital output only) 1: Alarm only 2: Fault 3: Restart (time set by Q4-12) <b>Note:</b> Q4-10 detection time delay is only applicable to settings 2 and 3.	Default: 1 Range: 0 to 3	–
Q4-12 (0EF9)	Water Level Control Auto-Restart Time	WtrLvl Restart	Sets the length of time that the drive will wait before attempting an auto-restart of the Low Water Level fault. This parameter is effective only when Q4-11 is set to 3 and L5-01 is set to a value greater than 0.	Default: 5.0 min Min.: 0.1 Max.: 6000.0	–
Q4-13 (0EFA) <input type="checkbox"/>	Level Control Proportional Gain	Lvl Ctrl P Gain	Sets the proportional gain for the water level control.	Default: 2.00 Min.: 0.00 Max.: 25.00	–
Q4-14 (0EFB) <input type="checkbox"/>	Level Control Integral Time	Lvl Ctrl I Time	Sets the integral time for the water level control. Setting this parameter to 0.0 disables the water level control integrator.	Default: 5.0 s Min.: 0.0 Max.: 360.0	–
Q4-15 (0EFC)	Low Water Level Detection Time Unit	Low Lvl Det Unit 0: Minutes (min) 1: Seconds (sec)	Determines the time unit for Q4-10, Low Level Detection Time Delay. 0: Minutes (min) 1: Seconds (sec)	Default: 0 Range: 0, 1	–



No. (Addr. Hex)	Name	LCD Display	Description	Values	Page
Q4-16 (0EFD)	Water Level Analog Input Wire-Break Detection	WL Wire Break 0: No Display 1: Alarm Only 2: Fault	Sets the behavior when the analog input selected for water level feedback is programmed to receive a 4-20 mA signal and the signal is lost. 0: No display 1: Alarm only 2: Fault (no retry, coast to stop)	Default: 2 Range: 0 to 2	-
Q4-20 (0F02) <2>	Water Level Speed Control 1	WaterLvl SpdCtrl 0: Disabled 1: Enabled	Selects whether the Water Level Controller has an effect on output speed. 0: Disabled 1: Enabled	Default: 1 Range: 0, 1	-
Q4-22 (0F04) <3>	Water Level Decimal Place Position	Water Lvl Dec Pt	Sets the number of decimal places for the Water Level parameters and monitor: 0: No Dec (XXXXX) 1: 1 Dec (XXXX.X) 2: 2 Dec (XXX.XX) 3: 3 Dec (XX.XXX)	Default: 1 Range: 0 to 3	-
Q4-25 (0F07) <3>	Water Level Control Activation Level	WaterLvl Act Lvl	When the amount of water above the sensor drops below this level for more than the Q4-26 time, Water Level Control is activated allowing it to affect the output frequency. When the amount of water below the sensor rises above this level for more than the Q4-26 time, Water Level Control is deactivated causing it to have no effect on the output frequency. Water Level Control is always active (if enabled) when set to 0.	Default: 0.0 ft. Range: 0.0 to 1200.0	-
Q4-26 (0F08) <3>	Water Level Control Activation/Deactivation Delay	WaterLvl Act Dly	When the amount of water above the sensor drops below the Q4-25 level for more than this time, Water Level Control is activated allowing it to affect the output frequency. When the amount of water below the sensor rises above the Q4-25 level for more than this time, Water Level Control is deactivated causing it to have no effect on the output frequency.	Default: 2 s Range: 0 to 3600	-

<1> Units are determined by Q4-15, Low Water Level Detection Time Unit, setting.

<2> Available in drive software versions PRG: 8552 and later. Not available in drive models 4A0930 and 4A1200.

<3> Available in drive software versions PRG: 8554 and later. Not available in drive models 4A0930 and 4A1200.

### ◆ Q5: Suction Pressure Control

No. (Addr. Hex)	Name	LCD Display	Description	Values	Page
Q5-01 (0F20)	Suction Pressure Select	Suction Pres Sel 0: Disabled 1: Suction Pressure 2: Vacuum ("Hg)	Sets the method of operation for the Suction Control / Vacuum Control function. 0: Disabled 1: Suction pressure (PSI) 2: Vacuum ("Hg)	Default: 0 Range: 0 to 2	-
Q5-02 (0F21) [RUN]	Suction Transducer Scaling	Suction Scaling	Sets the full scale (20 mA) output of the pressure transducer that is connected to the analog input terminal programmed for "WaterLvl/Suction" (H3-0□ = 23).	Default: 100.0 <1> Min.: 5.0 Max.: 1200.0	-
Q5-03 (0F22) [RUN]	Suction Pressure Setpoint	Suction Setpoint	Sets the amount of suction pressure to which the drive will attempt to regulate.	Default: 20.0 <1> Min.: 0.0 Max.: 1200.0	242
Q5-04 (0F23) [RUN]	Minimum Suction Pressure	Min Suction Pres	Sets the level below which the suction pressure must fall for longer than the Q5-05 time to put the drive to sleep and turn off all lag pumps.	Default: 10.0 <1> Min.: 0.0 Max.: 1200.0	-
Q5-05 (0F24) [RUN]	Suction Pressure Sleep Delay Time	SP Sleep Dly Tm	Sets the length of time that the drive will delay after suction pressure drops below the level set in Q5-04 before going to sleep.	Default: 5 s Min.: 0 Max.: 3600	-
Q5-06 (0F25) [RUN]	Wake-Up Suction Pressure	Wake-Up Pres	Sets the level above which the suction pressure must rise for the time set in Q5-07 for the drive to wake up when it has been put to sleep via parameter Q5-04, Minimum Suction Pressure.	Default: 30.0 <1> Min.: 0.0 Max.: 1200.0	242
Q5-07 (0F26)	Suction Pressure Sleep Wake-Up Time	SP Wake-up Time	Sets the length of time for which the pressure must rise above the level set in Q5-06 to wake up the drive when it has been put to sleep via parameter Q5-04, Minimum Suction Pressure.	Default: 1 s Min.: 0 Max.: 3600	-

## B.13 Q: PID Controller Parameters

No. (Addr. Hex)	Name	LCD Display	Description	Values	Page
Q5-08 (0F27) [RUN]	Suction Pressure Control Minimum Speed	Suction Min Spd	Sets the minimum speed at which the drive will run when the drive is controlling suction pressure. When the drive is controlling outlet pressure or this parameter is set lower than P1-06 and P4-12, parameters P1-06 and P4-12 will be used as the minimum speed.	Default: 0.00 Hz Min.: 0.00 Max.: 400.00	–
Q5-09 (0F28) [RUN]	Low Suction Pressure Detection Level	Low Pres Detect	Sets the level below which the suction pressure must fall for the time set in Q5-10 to trigger a drive response according to Q5-11, Low Suction Pressure Behavior Select. Setting this parameter to 0.0 will disable the function. <b>Note:</b> Q4-10 detection time delay is only applicable when Q4-11 = 2 or 3. When Q5-01 = 2, Q5-10 detection time delay applies to settings 1, 2, and 3.	Default: 0.0 <?> Min.: 0.0 Max.: 1200.0	242
Q5-10 (0F29) [RUN]	Low Suction Pressure Detection Time	Low Pres Det Tm	Sets the length of time that the water level must fall below the level set in Q5-09 to trigger drive response. Applicable when Q5-11 = 2 or 3. When Q5-01 = 2, Q5-10 detection time delay applies to Q5-11 settings 1, 2, and 3.	Default: 0.1 <?> Min.: 0.0 Max.: 300.0	243
Q5-11 (0F2A)	Low Suction Pressure Behavior Select	Low Pressure Sel 0: No Display 1: Alarm Only 2: Fault 3: Restart (Q5-15)	Determines drive response when the suction pressure drops below the level set in Q5-09 for longer than the time set in Q5-10. 0: No display (digital output only) 1: Alarm only 2: Fault 3: Auto-restart (time set by Q5-15) <b>Note:</b> Q5-10 detection time delay only applies to settings 2 and 3 while Q5-01 = 1. When Q5-01 = 2, Q5-10 detection time delay applies to settings 1, 2, and 3.	Default: 1 Range: 0 to 3	243
Q5-12 (0F2B) [RUN]	High Suction Pressure Detection Level	Hi Pres Detect	Sets the level above which the suction pressure must rise for the time set in Q5-13 to trigger a drive response according to Q5-14. Setting this parameter to 0.0 disables the function. <b>Note:</b> Q5-13 detection time delay only applies when Q5-14 = 2 or 3.	Default: 0.0 <?> Min.: 0.0 Max.: 1200.0	–
Q5-13 (0F2C) [RUN]	High Suction Pressure Detection Time	Hi Pres Det Tm	Sets the length of time that the water level must rise above the level set in Q5-12 to trigger drive response. Applicable when Q5-14 = 2 or 3.	Default: 0.1 <?> Min.: 0.0 Max.: 300.0	–
Q5-14 (0F2D)	High Suction Pressure Behavior Select	Hi Pressure Sel 0: No Display 1: Alarm Only 2: Fault 3: Restart (Q5-15)	Determines drive response when the suction pressure rises above the level set in Q5-12 for longer than the time set in Q5-13. 0: No display 1: Alarm only 2: Fault 3: Auto-restart (time set by Q5-15) <b>Note:</b> Q5-13 detection time delay only applies to settings 2 and 3.	Default: 1 Range: 0 to 3	–
Q5-15 (0F2E)	Suction Pressure Auto-Restart Time	Suction Restart	Sets the length of time that the drive will wait before attempting an auto-restart of the Low Suction or High Suction fault. Parameter is only effective when Q5-11 is set to 3 or Q5-14 is set to 3 and L5-01 is greater than 0.	Default: 5.0 min Min.: 0.1 Max.: 6000.0	–
Q5-16 (0F2F) [RUN]	Suction Control Proportional Gain	Suction P Gain	Sets the proportional gain for the suction pressure control.	Default: 2.00 Min.: 0.00 Max.: 25.00	243
Q5-17 (0F30) [RUN]	Suction Control Integral Time	Suction I Time	Sets the integral time for the suction pressure control. Setting this parameter to 0.0 disables the suction pressure control integrator.	Default: 5.0 s Min.: 0.0 Max.: 360.0	243
Q5-18 (0F31)	Suction Pressure Detection Time Unit	SuctionPresUnit 0: Minutes (min) 1: Seconds (sec)	Sets the time unit for Q5-10 and Q5-13. 0: Minutes (min) 1: Seconds (sec)	Default: 0 Range: 0, 1	–
Q5-19 (0F32)	Suction Pressure Analog Input Wire-Break Detection	SP Wire Break 0: No Display 1: Alarm Only 2: Fault	Sets the behavior when the analog input selected for suction pressure feedback is programmed to receive a 4 to 20 mA signal and the signal is lost. 0: Disabled 1: Alarm only 2: Fault (no retry, coast to stop)	Default: 2 Range: 0 to 2	–

No. (Addr. Hex)	Name	LCD Display	Description	Values	Page
Q5-20 (0F36) <3>	Suction Pressure Speed Control	SucPres Spd Ctrl 0: Disabled 1: Enabled	Selects whether the Suction Pressure Controller has an effect on output speed. 0: Disabled 1: Enabled	Default: 1 Range: 0, 1	–
Q5-22 (0F38) <4>	Suction Pressure Decimal Place Position	Suc Press Dec Pt 0: No Dec (XXXXXX) 1: 1 Dec (XXXX.X) 2: 2 Dec (XXX.XX) 3: 3 Dec (XX.XXX)	Sets the number of decimal places for the Suction Pressure parameters and monitor: 0: No Dec (XXXXXX) 1: 1 Dec (XXXX.X) 2: 2 Dec (XXX.XX) 3: 3 Dec (XX.XXX)	Default: 1 Range: 0 to 3	–
Q5-25 (0F3B) <4>	Suction Pressure Control Activation Level	SucPres Act Lvl	When the suction pressure drops below this level for more than the Q5-26 time, Suction Pressure Control is activated allowing it to affect the output frequency. When the suction pressure rises above this level for more than the Q5-26 time, Suction Pressure is deactivated causing it to have no effect on the output frequency. Suction Pressure Control is always active (if enabled) when set to 0.	Default: 10.0 PSI Range: 0.0 to 1200.0 <1>	–
Q5-26 (0F3C) <4>	Suction Pressure Control Activation/Deactivation Delay	SucPres Act Dly	When the suction pressure drops below the Q5-25 level for more than this time, Suction Pressure Control is activated allowing it to affect the output frequency. When the suction pressure rises above the Q5-25 level for more than this time, Suction Pressure Control is deactivated causing it to have no effect on the output frequency.	Default: 2 s Range: 0 to 3600	–

<1> Units are determined by Q5-01, Suction Pressure Select, setting.

<2> Units are determined by Q5-18, Suction Pressure Detection Time Unit, setting.







<3> Available in drive software versions PRG: 8552 and later. Not available in drive models 4A0930 and 4A1200.

<4> Available in drive software versions PRG: 8554 and later. Not available in drive models 4A0930 and 4A1200.

## ◆ Q6: PI Auxiliary Control

No. (Addr. Hex)	Name	LCD Display	Description	Values	Page
Q6-01 (0F50) <1>	PI Auxiliary Control Selection	PI Aux Ctrl Sel 0: Disabled 1: Enabled	Sets the mode of operation for the PI Auxiliary Control function. 0: Disabled 1: Enabled	Default: 0 Range: 0, 1	–
Q6-02 (0F51) RUN <1>	PI Auxiliary Control Feedback Scale	PI Aux Lvl Scale	Sets the full scale (10 V or 20 mA) output of the pressure transducer connected to the analog input terminal programmed for “PI Aux FB Level” (H3-□□ = 27).	Default: 145.0 PSI <3> Min.: 1.0 Max.: 6000.0	–
Q6-03 (0F52) RUN <1>	PI Auxiliary Control Setpoint	PI Aux Setpoint	Sets the level to which the drive will attempt to regulate.	Default: 20.0 PSI <3> Min.: 0.0 Max.: 6000.0	–
Q6-04 (0F53) RUN <1>	PI Auxiliary Control Minimum Level	PI Aux Min Lvl	Sets the level below which the drive must fall for longer than the time set in Q6-05 time before the drive goes to sleep and turns off all lag pumps. <b>Note:</b> This feature is disabled when set to 0.0.	Default: 10.0 PSI <3> Min.: 0.0 Max.: 6000.0	–
Q6-05 (0F54) RUN <1>	PI Auxiliary Control Sleep Delay Time	Sleep Dly Time	Inverse Acting (Q6-23 = 1): Sets the amount of time that the drive will delay before going to sleep after the level drops below Q6-04 setting. Normal Acting (Q6-23 = 0): Sets the amount of time that the drive will delay before going to sleep after the level rises above Q6-24 setting Range: 0 to 3600 s Default 5 s	Default: 5 s Min.: 0 Max.: 3600	–

## B.13 Q: PID Controller Parameters

No. (Addr. Hex)	Name	LCD Display	Description	Values	Page
Q6-06 (0F55)  </>	PI Auxiliary Control Wake-up Level	Wake-Up Level	This parameter is applicable when the drive has been forced to sleep based on the setting of Q6-04 or Q6-24 (PI Auxiliary Control Minimum Level or PI Auxiliary Control Maximum Level). Inverse Acting (Q6-23 = 1): The PI Aux Feedback must rise above the level set in this parameter for longer than the time set in Q6-07 to wake up. Normal Acting (Q6-23 = 0): The PI Aux Feedback must fall below this level for longer than the time set in Q6-07 to wake up.	Default: 30.0 PSI Min.: 0.0 Max.: 999.9 <4>	242
Q6-07 (0F56) </>	PI Auxiliary Control Wake-up Time	Wake-up Time	This parameter is applicable when the drive has been forced to sleep based on the setting of Q6-04 or Q6-24 (PI Auxiliary Control Minimum Level or PI Auxiliary Control Maximum Level). Inverse Acting (Q6-23 = 1): The PI Aux Feedback must rise above the level set in Q6-06 for longer than the time set in this parameter to wake up. Normal Acting (Q6-23 = 0): The PI Aux Feedback must fall below the level set in Q6-06 for longer than the time set in this parameter to wake up.	Default: 1 s Min.: 0 Max.: 3600	–
Q6-08 (0F57)  </>	PI Auxiliary Control Minimum Speed	PI Aux Min Spd	Sets the minimum speed at which the drive will be allowed to run when the PI Auxiliary Control is actively affecting the output speed. P1-06 and P4-12 (Minimum Pump Speed and Thrust Bearing Frequency) will be used as the minimum speed when PI Aux Control is not affecting the output speed or when this parameter is set to a value less than P1-06 and P4-12.	Default: 0.00 Hz Min.: 0.00 Max.: 400.00	–
Q6-09 (0F58)  </>	PI Auxiliary Control Low Level Detection	Low Level Detect	Sets the level below which the drive must fall for the longer than the time set in Q6-10 to respond depending on the Q6-11 setting. Setting this parameter to 0.0 disables this detection. <b>Note:</b> Q6-10 detection time delay only applies to Q6-11 settings 2 and 3 (Fault and Auto-Restart (time set by Q6-15)).	Default: 0.0 PSI Min.: 0.0 Max.: 999.9 <5>	–
Q6-10 (0F59)  </>	PI Auxiliary Control Low Level Detection Time	Low Lvl DetTime	Sets the amount of time for which the PI Aux Feedback must drop below the Q6-09 setting before the drive will react if Q6-11 = 2, 3.	Default: 0.1 min <2> Min.: 0.0 Max.: 300.0	–
Q6-11 (0F5A) </>	PI Auxiliary Control Low Level Detection Selection	Low Lvl Det Sel 0: No Display 1: Alarm Only 2: Fault 3: (Q6-15) Restart	Determines drive response when the level drops below the Q6-09 setting for longer than the time set in Q6-10. 0: No Display (Digital Output Only) 1: Alarm Only 2: Fault 3: Auto-Restart (time set by Q6-15) <b>Note:</b> Q6-10 detection time delay only applies to settings 2 and 3.	Default: 1 Range: 0 to 3	–
Q6-12 (0F5B)  </>	PI Auxiliary Control High Level Detection	Hi Level Detect	Sets the value above which the level must rise for longer than the time set in A6-13 to respond based on the Q6-14 setting. Setting this parameter to 0.0 disables this detection. <b>Note:</b> Q6-13 detection time delay only applies to Q6-14 settings 2 and 3.	Default: 0.0 PSI Min.: 0.0 Max.: 999.9 <6>	–
Q6-13 (0F5C)  </>	PI Auxiliary Control High Level Detection Time	Hi Lvl Det Time	Sets the length of time that the level must be above the Q6-12 setting before the drive will react when Q6-14 = 2, 3.	Default: 0.1 min <2> Min.: 0.0 Max.: 300.0	–
Q6-14 (0F5D) </>	PI Auxiliary Control High Level Detection Selection	High Lvl Det Sel 0: No Display 1: Alarm Only 2: Fault 3: (Q6-15) Restart	Determines drive response when the level rises above the Q6-12 setting for longer than the time set in Q6-13. 0: No Display 1: Alarm Only 2: Fault 3: Auto-Restart (time set by Q6-15) <b>Note:</b> Q6-10 detection time delay only applies to settings 2 and 3.	Default: 1 Range: 0 to 3	–

No. (Addr. Hex)	Name	LCD Display	Description	Values	Page
Q6-15 (0F5E) </>	PI Auxiliary Control Level Detection Restart Time	Level Restart Tm	Sets the length of time the drive will wait before attempting an auto-restart of the “Low PI Aux Lvl” or the “High PI Aux Lvl” fault. This parameter is effective only when Q6-11 = 3 or Q6-14 = 3, and L5-01 > 0.	Default: 5.0 min Min.: 0.1 Max.: 6000.0	–
Q6-16 (0F5F) RUN </>	PI Auxiliary Control P Gain	PI Aux P Gain	Sets the proportional gain for the suction pressure control.	Default: 2.00 Min.: 0.00 Max.: 25.00	–
Q6-17 (0F60) RUN </>	PI Auxiliary Control I Time	PI Aux I Time	Sets the integral time for the suction pressure control. A setting of zero disables the integrator.	Default: 5.0 s Min.: 0.0 Max.: 360.0	–
Q6-18 (0F61) </>	PI Auxiliary Control Detection Time Unit	PI Aux Time Unit 0: Minutes (min) 1: Seconds (sec)	Sets the time unit for Q6-10 and Q6- 13. 0: Minutes (min) 1: Seconds (sec)	Default: 0 Range: 0, 1	–
Q6-19 (0F62) </>	PI Auxiliary Control Feedback Wirebreak	PI Aux WireBreak 0: No Display 1: Alarm Only 2: Fault	Sets the behavior of the analog input selected for PI Aux Feedback when it is programmed to receive a 4 to 20 mA signal and the signal is lost. 0: Disabled 1: Alarm Only 2: Fault (no retry, coast to stop)	Default: 2 Range: 0 to 2	–
Q6-20 (0F63) </>	PI Auxiliary Control Main PI Control	PI Aux Spd Cntrl 0: Disabled 1: Enabled	Selects whether the PI Auxiliary Controller has an effect on output speed. 0: Disabled 1: Enabled	Default: 1 Range: 0, 1	–
Q6-21 (0F64) </>	PI Auxiliary Control Level Unit Selection	PI Aux Lvl Unit 0: No Unit 1: PSI :lb/SqrInch 2: Pa:Pascals 3: Bar:Bar 4: "WC:InchOfWater 5: "Hg:Inch Mercury 6: ft: feet 7: m: meters 8: °F:DegFarenheit 9: °C:DegCelsius 10: %: Percent 11: kPA: kilopascal 26: Custom (Q6-32~34)	Set the unit displayed for the PI Aux Level parameters and monitor. 0: No unit 1: PSI: Pounds per square inch 2: Pa: Pascals 3: Bar: Bar 4: "WC: Inch of water 5: "Hg: Inch of Mercury 6: ft: feet 7: m: meters 8: °F: Degrees Fahrenheit 9: °C: Degrees Celsius 10: Percent 11: kPA: kilopascal <?> 26: Custom (Q6-32 to Q6-34) <?>	Default: 1 Range: 0 to 11; 26	–
Q6-22 (0F65) </>	PI Auxiliary Control Level Decimal Place Position	PI Aux LvlDecPt 0: No Dec (XXXXX) 1: 1 Dec (XXXX.X) 2: 2 Dec (XXX.XX) 3: 3 Dec (XX.XXX)	Sets the number of decimal places for the PI Aux Level parameters and monitor. 0: No Dec (XXXXX) 1: 1 Dec (XXXX.X) 2: 2 Dec (XXX.XX) 3: 3 Dec (XX.XXX)	Default: 1 Range: 0 to 3	–
Q6-23 (0F66) </>	PI Auxiliary Control Output Level Selection	PI Aux OutLvlSel 0: Direct Acting 1: Inverse Acting	Determines whether the PI Auxiliary Controller is Direct-acting (feedback higher than setpoint results in lower speed) or Inverse-acting (feedback lower than setpoint results in lower speed). 0: Direct Acting 1: Inverse Acting	Default: 1 Range: 0, 1	243
Q6-24 (0F67) RUN </>	PI Auxiliary Control Maximum Level	PI Aux Max Lvl	Sets the value above which the level must rise for longer than the time set in Q6-05 for the drive to go to sleep and turn off all lag pumps. This feature is disabled when set to 0.	Default: 0.0 PSI <?> Min.: 0.0 Max.: 6000.0	–

## B.13 Q: PID Controller Parameters

No. (Addr. Hex)	Name	LCD Display	Description	Values	Page
Q6-25 (0F68) <2>	PI Auxiliary Control Activation Level	PI Aux Act Lvl	For Inverse Acting (Q6-23 = 1): When the PI Aux Feedback drops below this level for more than the Q6-26 time, PI Aux Control is activated allowing it to affect the output frequency. When the PI Aux Feedback rises above this level for more than the Q6-26 time, PI Aux Control is deactivated causing it to have no effect on the output frequency. For Normal Acting (Q6-23 = 0): When the PI Aux Feedback rises above this level for more than the Q6-26 time, PI Aux Control is activated allowing it to affect the output frequency. When the PI Aux Feedback drops below this level for more than the Q6-26 time, PI Aux Control is deactivated causing it to have no effect on the output frequency. PI Auxiliary Control is always active (if enabled) when set to 0.	Default: 0.0 PSI Range: 0.0 to 6000.0 <3>	–
Q6-26 (0F69) <2>	PI Auxiliary Control Activation/ Deactivation Delay	PI Aux Act Dly	For Inverse Acting (Q6-23 = 1): When the PI Aux Feedback drops below the Q6-25 level for more than this time, PI Aux Control is activated allowing it to affect the output frequency. When the PI Aux Feedback rises above the Q6-25 level for more than this time, PI Aux Control is deactivated causing it to have no effect on the output frequency. For Normal Acting (Q6-23 = 0): When the PI Aux Feedback rises above the Q6-25 level for more than this time, PI Aux Control is activated allowing it to affect the output frequency. When the PI Aux Feedback drops below the Q6-25 level for more than this time, PI Aux Control is deactivated causing it to have no effect on the output frequency.	Default: 2 s Range: 0 to 3600 s	–
Q6-32 (0F6F) <2>	PI Aux Units Custom 1 <sup>st</sup> Character	PIAuxUnitCustom1	Sets the first character of the PI Aux custom unit display when Q6-21 = 26.	Default: 41 Range: 20 to 7A	–
Q6-33 (0F70) <2>	PI Aux Units Custom 2 <sup>nd</sup> Character	PIAuxUnitCustom2	Sets the second character of the PI Aux custom unit display when Q6-21 = 26.	Default: 41 Range: 20 to 7A	–
Q6-34 (0F71) <2>	PI Aux Units Custom 3 <sup>rd</sup> Character	PIAuxUnitCustom3	Sets the third character of the PI Aux custom unit display when Q6-21 = 26.	Default: 41 Range: 20 to 7A	–

<1> Available in drive software versions PRG: 8552 and later. Not available in drive models 4A0930 and 4A1200.

<2> Available in drive software versions PRG: 8554 and later. Not available in drive models 4A0930 and 4A1200.

<3> Units depend on Q6-21, PI Auxiliary Control Level Unit Selection. Resolution depends on Q6-22, PI Auxiliary Control Level Decimal Place Position.

<4> Range is 0.0 to 999.9 with sign-bit “-” or “+” indicating Delta to Setpoint (Q6-03).

<5> Range is 0.0 to 999.9 with sign-bit “-” indicating Delta to Setpoint (Q6-03).

<6> Range is 0.0 to 999.9 with sign-bit “+” indicating Delta to Setpoint (Q6-03).

## B.14 S: Special Application

### ◆ S1: Dynamic Noise Control Function

No. (Addr. Hex)	Name	LCD Display	Description	Values	Page
S1-01 (3200)	Dynamic Audible Noise Control Function Selection	Dyn Noise Ctrl 0: Disabled 1: Enabled	<b>V/f</b> 0: Disabled 1: Enabled	Default: 0 Range: 0, 1	–
S1-02 (3201)	Voltage Reduction Rate	Volt Reduce Amt	<b>V/f</b> Sets the rate at which the output voltage will be reduced as a percentage of the V/f pattern when operating with no load.	Default: 50.0% Min.: 50.0 Max.: 100.0	–
S1-03 (3202)	Voltage Restoration Level	V Reduce On Lvl	<b>V/f</b> Sets the level when the drive should start restoring the voltage as a percentage of the drive rated torque.	Default: 20.0% Min.: 0.0 Max.: 90.0	–
S1-04 (3203)	Voltage Restoration Complete Level	V Reduce Off Lvl	<b>V/f</b> Sets the level at which voltage restoration for the V/f pattern is complete as a percentage of the drive rated torque. If the output torque rises above the value of S1-04, then the voltage will be controlled in a manner specified by the V/f pattern setting.	Default: 50.0% Min.: S1-03 + 10.0 Max.: 100.0	–
S1-05 (3204)	Voltage Restoration Sensitivity Time Constant	Sensitivity Time	<b>V/f</b> Sets the level of sensitivity of the output torque and LPF time constants for the voltage reduction rate. The level of sensitivity can be adjusted in accordance with the load response.	Default: 1.000 s Min.: 0.000 Max.: 3.000	–
S1-06 (3205)	Voltage Restoration Time Constant at Impact	Impact Load Time	<b>V/f</b> Sets the voltage restoration time constant if an impact load is added.	Default: 0.050 s Min.: 0.000 Max.: 1.000	–

### ◆ S2: Programmable Run Timers

No. (Addr. Hex)	Name	LCD Display	Description	Values	Page
S2-01 (3206)	Sequence Timer 1 Start Time	Tmr 1 Start Time	Sets the start time for timer 1. <b>Note:</b> The value must be set less than or equal to S2-02 in drive software versions PRG: 8551 and earlier.	Default: 12:00AM <> Min.: 12:00AM Max.: 11:59PM <>	–
S2-02 (3207)	Sequence Timer 1 Stop Time	Tmr 1 Stop Time	Sets the stop time for timer 1. <b>Note:</b> The value must be set greater than or equal to S2-01 in drive software versions PRG: 8551 and earlier.	Default: 12:00AM <> Min.: 12:00AM Max.: 11:59PM <>	–
S2-03 (3208)	Sequence Timer 1 Day Selection	Tmr 1 Day Sel 0: Timer disabled 1: Daily 2: Mon - Fri 3: Sat - Sun 4: Monday 5: Tuesday 6: Wednesday 7: Thursday 8: Friday 9: Saturday 10: Sunday	Sets the days for which sequence timer 1 is active. 0: Timer disabled 1: Daily 2: Mon - Fri 3: Sat - Sun 4: Monday 5: Tuesday 6: Wednesday 7: Thursday 8: Friday 9: Saturday 10: Sunday	Default: 0 Range: 0 to 10	–
S2-04 (3209)	Sequence Timer 1 Selection	Tmr 1 Seq Sel 0: Digital Out Only 1: Run 2: Run - PI Disable 3: Allow Alternation	Sets the action that occurs when sequence timers 1 is active. 0: Digital output only 1: Run 2: Run - PI disable 3: Allow Alternation <>	Default: 0 Range: 0 to 3	245

## B.14 S: Special Application

No. (Addr. Hex)	Name	LCD Display	Description	Values	Page
S2-05 (320A)	Sequence Timer 1 Reference Source	Tmr 1 Ref Source 0: Operator (d1-01/Q1-01) 0: Operator (d1-02/Q1-02) 0: Operator (d1-03/Q1-03) 0: Operator (d1-04/Q1-04) 4: Terminals 5: Serial com 6: Option PCB 7: Pulse Input 8: Set by b1-01	Selects the frequency reference source used for running the drive when sequence timer 1 is active (only applicable when S2-04 is set to 1 or 2). 0: Operator (d1-01/Q1-01) 1: Operator (d1-02/Q1-02) 2: Operator (d1-03/Q1-03) 3: Operator (d1-04/Q1-04) 4: Terminals 5: Serial communication 6: Option card 7: Pulse input 8: Set by b1-01	Default: 8 Range: 0 to 8	–
S2-06 (320B)	Sequence Timer 2 Start Time	Tmr 2 Start Time	Sets the start time for timer 2. <b>Note:</b> The value must be set less than or equal to S2-07 in drive software versions PRG: 8551 and earlier.	Default: 12:00AM <?> Min.: 12:00AM Max.: 11:59PM </?>	–
S2-07 (320C)	Sequence Timer 2 Stop Time	Tmr 2 Stop Time	Sets the stop time for timer 2. <b>Note:</b> The value must be set greater than or equal to S2-06 in drive software versions PRG: 8551 and earlier.	Default: 12:00AM <?> Min.: 12:00AM Max.: 11:59PM </?>	–
S2-08 (320D)	Sequence Timer 2 Day Selection	Tmr 2 Day Sel 0: Timer Disabled 1: Daily 2: Mon - Fri 3: Sat - Sun 4: Monday 5: Tuesday 6: Wednesday 7: Thursday 8: Friday 9: Saturday 10: Sunday	Sets the days for which sequence timer 2 is active. 0: Timer disabled 1: Daily 2: Mon - Fri 3: Sat - Sun 4: Monday 5: Tuesday 6: Wednesday 7: Thursday 8: Friday 9: Saturday 10: Sunday	Default: 0 Range: 0 to 10	–
S2-09 (320E)	Sequence Timer 2 Selection	Tmr 2 Seq Sel 0: Digital Out Only 1: Run 2: Run - PI Disable 3: AllowAlternation	Sets the action that occurs when sequence timer 2 is active. 0: Digital output only 1: Run 2: Run - PI disable 3: Allow Alternation <?>	Default: 0 Range: 0 to 3	245
S2-10 (320F)	Sequence Timer 2 Reference Source	Tmr 2 Ref Source 0: Operator (d1-01) 1: Operator (d1-02) 2: Operator (d1-03) 3: Operator (d1-04) 4: Terminals 5: Serial Com 6: Option PCB 7: Pulse Input 8: Set by b1-01	Selects the frequency reference source used for running the drive when sequence timer 2 is active (only applicable when S2-09 is set to 1 or 2). 0: Operator (d1-01/Q1-01) 1: Operator (d1-02/Q1-02) 2: Operator (d1-03/Q1-03) 3: Operator (d1-04/Q1-04) 4: Terminals 5: Serial communication 6: Option card 7: Pulse input 8: Set by b1-01	Default: 8 Range: 0 to 8	–
S2-11 (3210)	Sequence Timer 3 Start Time	Tmr 3 Start Time	Sets the start time for timer 3. <b>Note:</b> The value must be set less than or equal to S2-12 in drive software versions PRG: 8551 and earlier.	Default: 12:00AM <?> Min.: 12:00AM Max.: 11:59PM </?>	–
S2-12 (3211)	Sequence Timer 3 Stop Time	Tmr 3 Stop Time	Sets the stop time for timer 3. <b>Note:</b> The value must be set greater than or equal to S2-11 in drive software versions PRG: 8551 and earlier.	Default: 12:00AM <?> Min.: 12:00AM Max.: 11:59PM </?>	–



No. (Addr. Hex)	Name	LCD Display	Description	Values	Page
S2-13 (3212)	Sequence Timer 3 Day Selection	Tmr 3 Day Sel 0: Timer Disabled 1: Daily 2: Mon - Fri 3: Sat - Sun 4: Monday 5: Tuesday 6: Wednesday 7: Thursday 8: Friday 9: Saturday 10: Sunday	Sets the days for which sequence timer 3 is active. 0: Timer disabled 1: Daily 2: Mon - Fri 3: Sat - Sun 4: Monday 5: Tuesday 6: Wednesday 7: Thursday 8: Friday 9: Saturday 10: Sunday	Default: 0 Range: 0 to 10	-
S2-14 (3213)	Sequence Timer 3 Selection	Tmr 3 Seq Sel 0: Digital out only 1: Run 2: Run - PI Disable 3: Allow Alternation	Sets the action that occurs when sequence timer 3 is active. 0: Digital output only 1: Run 2: Run - PI disable 3: Allow Alternation	Default: 0 Range: 0 to 3	245
S2-15 (3214)	Sequence Timer 3 Reference Source	Tmr 3 Ref Source 0: Opr (dx-0x/Qx-0x) 1: Opr (dx-0x/Qx-0x) 2: Opr (dx-0x/Qx-0x) 3: Opr (dx-0x/Qx-0x) 4: Terminals 5: Serial Com 6: Option PCB 7: Pulse Input 8: Set by b1-01	Selects the frequency reference source used for running the drive when sequence timer 3 is active (only applicable when S2-14 is set to 1 or 2). 0: Operator (d1-01/Q1-01) 1: Operator (d1-02/Q1-02) 2: Operator (d1-03/Q1-03) 3: Operator (d1-04/Q1-04) 4: Terminals 5: Serial communication 6: Option card 7: Pulse input 8: Set by b1-01	Default: 8 Range: 0 to 8	-
S2-16 (3215)	Sequence Timer 4 Start Time	Tmr 4 Start Time	Sets the start time for timer 4. <b>Note:</b> The value must be set less than or equal to S2-17 in drive software versions PRG: 8551 and earlier.	Default: 12:00AM Min.: 12:00AM Max.: 11:59PM	-
S2-17 (3216)	Sequence Timer 4 Stop Time	Tmr 4 Stop Time	Sets the stop time for timer 4. The value must be set greater than or equal to S2-16. <b>Note:</b> The value must be set greater than or equal to S2-16 in drive software versions PRG: 8551 and earlier.	Default: 12:00AM Min.: 12:00AM Max.: 11:59PM	-
S2-18 (3217)	Sequence Timer 4 Day Selection	Tmr 4 Day Sel 0: Timer Disabled 1: Daily 2: Mon - Fri 3: Sat - Sun 4: Monday 5: Tuesday 6: Wednesday 7: Thursday 8: Friday 9: Saturday 10: Sunday	Sets the days for which sequence timer 4 is active. 0: Timer disabled 1: Daily 2: Mon - Fri 3: Sat - Sun 4: Monday 5: Tuesday 6: Wednesday 7: Thursday 8: Friday 9: Saturday 10: Sunday	Default: 0 Range: 0 to 10	-
S2-19 (3218)	Sequence Timer 4 Selection	Tmr 4 Seq Sel 0: Digital Out Only 1: Run 2: Run - PI Disable 3: Allow Alternation	Sets the action that occurs when sequence timer 4 is active. 0: Digital output only 1: Run 2: Run - PI disable 3: Allow Alternation	Default: 0 Range: 0 to 3	245
S2-20 (3219)	Sequence Timer 4 Reference Source	Tmr 4 Ref Source 0: Opr (dx-0x/Qx-0x) 1: Opr (dx-0x/Qx-0x) 2: Opr (dx-0x/Qx-0x) 3: Opr (dx-0x/Qx-0x) 4: Terminals 5: Serial Com 6: Option PCB 7: Pulse Input 8: Set by b1-01	Selects the frequency reference source used for running the drive when sequence timer 4 is active (only applicable when S2-19 is set to 1 or 2). 0: Operator (d1-01/Q1-01) 1: Operator (d1-02/Q1-02) 2: Operator (d1-03/Q1-03) 3: Operator (d1-04/Q1-04) 4: Terminals 5: Serial communication 6: Option card 7: Pulse input 8: Set by b1-01	Default: 8 Range: 0 to 8	-

## B.14 S: Special Application

- <1> Setting the sequence timer start time to a higher value than the sequence timer stop time disables that sequence timer in drive software versions PRG: 8551 and earlier.
- <2> Available in drive software versions PRG: 8552 and later. Not available in drive models 4A0930 and 4A1200.
- <3> Default is 00:00 and range is 00:00 to 24:00 when o4-20 is set to 1 (24-hour).

### ◆ S3: Secondary PI (PI2) Control

No. (Addr. Hex)	Name	LCD Display	Description	Values	Page
S3-01 (321A) <span style="border: 1px solid black; padding: 1px;">RUN</span>	Secondary PI Enable Selection	PI2 Enable Sel 0: Disabled 1: Always 2: Drive Running 3: Motor Running	Determines when the secondary PI controller is enabled. 0: Disabled 1: Always 2: Drive running 3: Motor running  <b>Note:</b> Setting 3 does not run the motor at zero speed, baseblock, or in DC injection.	Default: 0 Range: 0 to 3	–
S3-02 (321B) <span style="border: 1px solid black; padding: 1px;">RUN</span>	Secondary PI User Display	PI2 UsrDspMaxVal	Sets the scale value of 100% PI input.	Default: 10000 Min.: 0 Max.: 60000	–
S3-03 (321C) <span style="border: 1px solid black; padding: 1px;">RUN</span>	Secondary PI Display Digits	PI2 UsrDspDigits 0: No Dec (XXXXX) 1: 1 Dec (XXXX.X) 2: 2 Dec (XXX.XX) 3: 3 Dec (XX.XXX)	Sets the decimal place display for secondary PI units. 0: No decimal places 1: One decimal place 2: Two decimal places 3: Three decimal places	Default: 2 Range: 0 to 3	–
S3-04 (321D) <span style="border: 1px solid black; padding: 1px;">RUN</span>	Secondary PI Unit Selection	PI2 Unit Sel 0: "WC:InchOfWater 1: PSI :lb/SqrInch 2: GPM:Gallons/Min 3: °F:DegFahrenheit 4: CFM:Cubic ft/Min 5: CMH:Cubic m/Hr 6: LPH:Litres/Hr 7: LPS:Litres/Sec 8: Bar:Bar 9: Pa:Pascals 10: °C:DegCelsius 11: m: meters 12: ft: feet 13: LPM:Litres/Min 14: No unit 15: %	0: Inch of water (WC) 1: Pounds per square inch (PSI) 2: Gallons per minute (GPM) 3: Degrees Fahrenheit (F) 4: Cubic feet per minute (CFM) 5: Cubic meters per hour (CMH) 6: Liters per hour (LPH) 7: Liters per second (LPS) 8: Bar (Bar) 9: Pascals (Pa) 10: Degrees Celsius (C) 11: Meters (Mtr) (Ft: Feet) 12: Liters per minute (LPM) 13: Cubic meters per minute (CMM) 14: No unit 15: Percentage (%)	Default: 15 Range: 0 to 15	–
S3-05 (321E) <span style="border: 1px solid black; padding: 1px;">RUN</span>	Secondary PI Setpoint Value	PI2 Setpoint	Sets the secondary PI controller target value.	Default: 0.00 <1> Min.: 0.00 Max.: 600.00 <2>	–
S3-06 (321F) <span style="border: 1px solid black; padding: 1px;">RUN</span>	Secondary PI Proportional Gain Setting	PI2 Gain	Sets the proportional gain of the secondary PI controller. A setting of 0.00 disables P control.	Default: 1.00 Min.: 0.00 Max.: 25.00	–
S3-07 (3220) <span style="border: 1px solid black; padding: 1px;">RUN</span>	Secondary PI Integral Time Setting	PI2 I Time	Sets the integral time for the secondary PI controller. A setting of 0.0 s disables integral control.	Default: 1.0 s Min.: 0.0 Max.: 360.0	–
S3-08 (3221) <span style="border: 1px solid black; padding: 1px;">RUN</span>	Secondary PI Integral Limit Setting	PI2 I Limit	Sets the maximum output possible from the integrator.	Default: 100.0% Min.: 0.0 Max.: 100.0	–
S3-09 (3222) <span style="border: 1px solid black; padding: 1px;">RUN</span>	Secondary PI Output Upper Limit	PI2 Upper Limit	Sets the maximum output possible from the secondary PI controller.	Default: 100.0% Min.: 0.0 Max.: 100.0	–
S3-10 (3223) <span style="border: 1px solid black; padding: 1px;">RUN</span>	Secondary PI Output Lower Limit	PI2 Lower Lim	Sets the minimum output possible from the secondary PI controller.	Default: 0.00% Min.: -100.00 Max.: 100.00	–

No. (Addr. Hex)	Name	LCD Display	Description	Values	Page
S3-11 (3224) [RUN]	Secondary PI Output Level Selection	PI2 Out Lvl Sel 0: Direct Acting 1: Inverse Acting	Sets the secondary PI controller output direction. 0: Normal Output (direct acting) 1: Inverse Output (inverse acting)	Default: 0 Range: 0, 1	–
S3-12 (3225) [RUN]	Secondary PI Disable Mode	PI2 Disable Mode 0: No output 1: Lower Limit 2: Setpoint	Selects the secondary PI controller output when disabled. 0: No output (0%) 1: Lower Limit (S3-10) 2: Setpoint	Default: 0 Range: 0 to 2	–
S3-13 (3226) [RUN]	Secondary PI Low Feedback Detection Level	PI2 Low FB Lvl	Sets the secondary PI low feedback detection level.	Default: 0.00 <1> Min.: 0.00 Max.: 600.00 <2>	–
S3-14 (3227) [RUN]	Secondary PI Low Feedback Detection Time	PI2 Low FB Time	Sets the secondary PI low feedback detection delay time in seconds.	Default: 1.0 s Min.: 0.0 Max.: 25.5	–
S3-15 (3228) [RUN]	Secondary PI High Feedback Level	PI2 High FB Lvl	Sets the secondary PI high feedback detection level.	Default: 100.00 <1> Min.: 0.00 Max.: 600.00 <2>	–
S3-16 (3229) [RUN]	Secondary PI High Feedback Detection Time	PI2 High FB Tim	Sets the secondary PI high feedback detection delay time in seconds.	Default: 1.0 s Min.: 0.0 Max.: 25.5	–
S3-17 (322A) [RUN]	Secondary PI Feedback Detection Selection	PI2 FB Det Sel 0: PI2 Enabled 1: Always	Selects when secondary PI controller low and high feedback detection are active. 0: Secondary PI enabled 1: Always	Default: 0 Range: 0, 1	–

<1> Unit is determined by S3-04.

<2> Upper limit is S3-02, decimal placeholder is determined by S3-03.

## ◆ S6: Protection

No. (Addr. Hex)	Name	LCD Display	Description	Values	Page
S6-01 (3236)	Emergency Override Speed	E Override Speed	Sets the speed command used in emergency override mode when S6-02 = 0.	Default: 0.00 Hz Min.: 0.00 Max.: 400.00	–
S6-02 (3237)	Emergency Override Reference Selection	E OverrideRefSel 0: Use S6-01 Ref 1: Use Freq Ref	Selects the emergency override speed source. 0: Use S6-01 Reference 1: Use Frequency Reference	Default: 0 Range: 0, 1	–
S6-07 (323C)	Output Phase Loss Level for Dynamic Noise Control	DNC Outp Ph Loss	Reduces the output phase loss level when Dynamic Noise Control is active.	Default: 100.0% Min.: 10.0 Max.: 100.0	–

## B.15 T: Motor Tuning

Enter data into the following parameters to tune the motor and drive for optimal performance.

### ◆ T1: Induction Motor Auto-Tuning

No. (Addr. Hex)	Name	LCD Display	Description	Values	Page
T1-01 (0701)	Auto-Tuning Mode Selection	Tuning Mode Sel 0: Standard Tuning 1: Tune-No Rotate1 2: Term Resistance 3: V/f Engy Sav Tun 4: Tune-No Rotate2	0: Standard 1: Tune-No Rotate1 2: Stationary Auto-Tuning for Line-to-Line Resistance 3: Rotational Auto-Tuning for V/f Control Energy Saving 4: Tune-No Rotate2	Default: <1> Range: 0 to 4	–
T1-02 (0702)	Motor Rated Power	Mtr Rated Power	Sets the motor rated power as specified on the motor nameplate. <b>Note:</b> Use the following formula to convert horsepower into kilowatts: 1HP = 0.746 kW.	Default: <2> Min.: 0.00 kW Max.: 650.00 kW	–
T1-03 (0703)	Motor Rated Voltage	Rated Voltage	Sets the motor rated voltage as specified on the motor nameplate.	Default: 200.0 V <3> Min: 0.0 Max: 255.0 <3>	–
T1-04 (0704)	Motor Rated Current	Rated Current	Sets the motor rated current as specified on the motor nameplate.	Default: <2> Min.: 10% of drive rated current Max.: 200% of drive rated current	–
T1-05 (0705)	Motor Base Frequency	Rated Frequency	Sets the rated frequency of the motor as specified on the motor nameplate.	Default: 60.0 Hz Min.: 0.0 Max.: 400.0	–
T1-06 (0706)	Number of Motor Poles	Number of Poles	Sets the number of motor poles as specified on the motor nameplate.	Default: 4 Min.: 2 Max.: 48	–
T1-07 (0707)	Motor Base Speed	Rated Speed	Sets the rated speed of the motor as specified on the motor nameplate.	Default: 1750 r/min Min.: 0 Max.: 24000	–
T1-09 (0709)	Motor No-Load Current (Stationary Auto-Tuning)	Motor No-Load Current	<b>OLV</b> Sets the no-load current for the motor. After setting the motor capacity to T1-02 and the motor rated current to T1-04, this parameter will automatically display the no-load current for a standard 4-pole Yaskawa motor. Enter the no-load current as indicated on the motor test report.	Default: – Min.: 0 A Max.: T1-04	–
T1-10 (070A)	Motor Rated Slip (Stationary Auto-Tuning)	Motor Rated Slip	<b>OLV</b> Sets the motor rated slip. After setting the motor capacity to T1-02, this parameter will automatically display the motor slip for a standard 4-pole Yaskawa motor. Enter the motor slip as indicated on the motor test report.	Default: – Min.: 0.00 Hz Max.: 20.00 Hz	–
T1-11 (070B)	Motor Iron Loss	Mtr Iron Loss(W)	<b>V/f</b> Sets the iron loss for determining the Energy Saving coefficient. The value is set to E2-10 (motor iron loss) set when the power is cycled. If T1-02 is changed, a default value appropriate for the motor capacity that was entered will appear.	Default: 14 W <4> Min.: 0 Max.: 65535	–

<1> Default depends on parameter A1-02, Control Mode Selection.

Setting 0 (V/f): Default is 2.

Setting 2 (OLV): Default is 0

<2> Default setting is dependent on parameter o2-04, Drive Model Selection.

<3> Values shown are specific to 200 V class drives. Double the value for 400 V class drives. Multiply the value by 2.875 for 600 V class drives.

<4> Default setting value differs depending on the motor code value and motor parameter settings.

## B.16 U: Monitors

Monitor parameters allow the user to view drive status, fault information, and other data concerning drive operation.

### ◆ U1: Operation Status Monitors

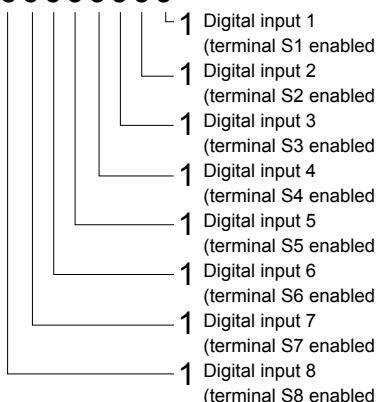
No. (Addr. Hex)	Name	LCD Display	Description	Analog Output Level	Unit
U1-01 (0040) <7>	Frequency Reference	Frequency Ref	Monitors the frequency reference. Display units are determined by o1-03.	10 V: Max frequency	0.01 Hz
U1-02 (0041) <7>	Output Frequency	Output Freq	Displays the output frequency. Display units are determined by o1-03.	10 V: Max frequency	0.01 Hz
U1-03 (0042) <7>	Output Current	Output Current	Displays the output current. <b>Note:</b> The unit is expressed in 1 A for models 4A0930 and 4A1200.	10 V: Drive rated current	<7> <7>
U1-04 (0043)	Control Method	Control Method	0: V/f Control 2: OLV Control	No signal output available	–
U1-05 (0044)	Motor Speed	Motor Speed	<b>OLV</b> Displays the motor speed feedback. Display units are determined by o1-03.	10 V: Max frequency	0.01 Hz
U1-06 (0045) <7>	Output Voltage Reference	Output Voltage	Displays the output voltage.	10 V: 200 Vrms <3>	0.1 Vac
U1-07 (0046) <7>	DC Bus Voltage	DC Bus Voltage	Displays the DC bus voltage.	10 V: 400 V <3>	1 Vdc
U1-08 (0047) <7>	Output Power	Output kWatts	Displays the output power (this value is calculated internally).	10 V: Drive capacity (motor capacity) kW	<7>
U1-09 (0048)	Torque Reference	Torque Reference	<b>OLV</b> Monitors the internal torque reference.	10 V: Motor rated torque	0.1%
U1-10 (0049) <7>	Input Terminal Status	Input Term Sts	Displays the input terminal status. <b>U1 - 10=00000000</b> 	No signal output available	–

## B.16 U: Monitors

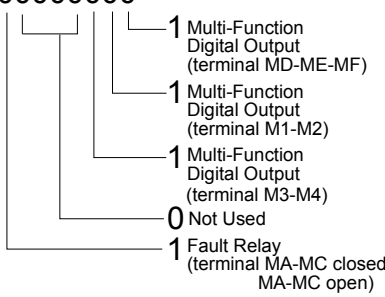
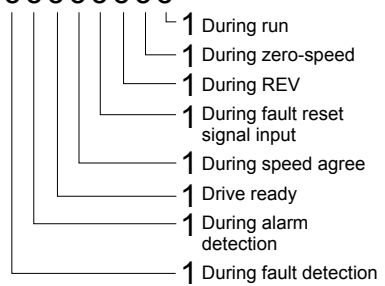
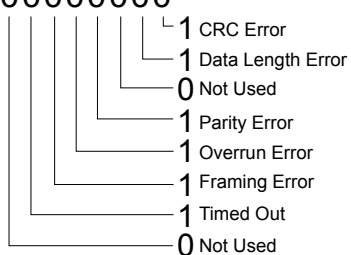
No. (Addr. Hex)	Name	LCD Display	Description	Analog Output Level	Unit
U1-11 (004A) <>	Output Terminal Status	Output Term Sts	Displays the output terminal status. <b>U1 - 11 = 00000000</b> 	No signal output available	–
U1-12 (004B)	Drive Status	Int Ctl Sts 1	Verifies the drive operation status. <b>U1 - 12 = 00000000</b> 	No signal output available	–
U1-13 (004E) <>	Terminal A1 Input Level	Term A1 Level	Displays the signal level to analog input terminal A1.	10 V: 100%	0.1%
U1-14 (004F) <>	Terminal A2 Input Level	Term A2 Level	Displays the signal level to analog input terminal A2.	10 V: 100%	0.1%
U1-15 (0050) <>	Terminal A3 Input Level	Term A3 Level	Displays the signal level to analog input terminal A3.	10 V: 100%	0.1%
U1-16 (0053)	Output Frequency after Soft Starter	SFS Output	Displays output frequency with ramp time and S-curves. Units determined by o1-03.	10 V: Max frequency	0.01 Hz
U1-18 (0061)	oPE Fault Parameter	OPE Error Code	Displays the parameter number that caused the oPE02 operation error.	No signal output available	–
U1-19 (0066)	MEMOBUS/Modbus Error Code	Transmit Err	Displays the contents of a MEMOBUS/Modbus error. <b>U1 - 19 = 00000000</b> 	No signal output available	–
U1-24 (007D)	Input Pulse Monitor	Term RP Inp Freq	Displays the frequency to pulse train input terminal RP.	Determined by H6-02	1 Hz
U1-25 (004D) <>	Software Number (Flash)	CPU 1 SW Number	FLASH ID	No signal output available	–
U1-26 (005B)	Software No. (ROM)	CPU 2 SW Number	ROM ID	No signal output available	–

No. (Addr. Hex)	Name	LCD Display	Description	Analog Output Level	Unit
U1-29 (07AA)	Software No. (PWM)	CPU 3 SW Number	PWM ID <b>Note:</b> This monitor is only displayed in models 4A0930 and 4A1200.	No signal output available	–
U1-75 (0851)	Time-Hour/Minute	Time Hr Min HHMM	Displays the current time (Hours and Minutes).	No signal output available	–
U1-76 (0852)	Date – Year	Date Year	Displays the current year.	No signal output available	–
U1-77 (0853)	Date – Month/Day	Date Mo Day MMDD	Displays the current date (Month and Date).	No signal output available	–
U1-78 (0854)	Date – Week Day	Date Week	Displays the current day of the week. 0: Sunday 1: Monday 2: Tuesday 3: Wednesday 4: Thursday 5: Friday 6: Saturday	No signal output available	–
U1-79 (0B9A) <5>	PI Feedback Back-up	PI Fdbk Backup	Displays the PI Feedback Back-up signal (H3-□□ = 24) used when the primary PI Feedback (H3-□□ = B) is lost.	No signal output available	dep. on P1-02
U1-80 (0B9B)	Geothermal Temperature Input	Geothermal Temp	Displays the geothermal temperature input after the gain and bias have been applied. This temperature is used by the Geothermal Function to determine the proper frequency at which to run the drive. This monitor is internally limited to -999.9 °F to +999.9 °F.	No signal output available	0.1 °F
U1-81 (0B9C) <6>	Differential PI Feedback	Diff PI Feedback	Differential Feedback signal (H3-□□ = 28).	No signal output available	dep. on P1-02
U1-82 (0B9D) <6>	Two Motor Time to Alternate	2Motor Alt Time	Time remaining before making a motor switch.	No signal output available	min
U1-83 (0B9E)	Flow Rate	Flow Rate	Displays the flow rate based on the pulse input frequency or the analog voltage (flow rate input) and parameters P6-01 and P6-04. A 2-second first order filter will be applied to this monitor.	Full scale: P6-01	dep. on P6-04 and P6-22
U1-84 (0B9F)	Accumulation Level - Millions	Volume * 1000000	Displays the recorded volume from the flow meter (pulse input or analog voltage). Total volume is calculated as follows: Total Volume = (U1-84 * 1000000) + (U1-85 * 1000) + U1-86 + U1-87	No signal output available	dep. on P6-16
U1-85 (0BA0)	Accumulation Level - Thousands	Volume * 1000			
U1-86 (0BA1)	Accumulation Level - Ones	Volume * 1			
U1-87 (0BA2)	Accumulation Level - Decimal	Volume * 0.0001			
U1-88 (N/A) <6>	Total Volume Accumulated	Total Vol (gal) or Total Vol (A-F)	Displays the total volume.	Full scale: N/A	dep. on P6-16
U1-89 (N/A) <6>	Delta Volume Accumulated	Delta Vol (gal) or Total Vol (A-F)	Displays the delta volume: Total Volume (U1-88/U1-84 to U1-87) - Starting Delta Volume (P6-36 to P6-39).	Full scale: N/A	dep. on P6-16
U1-90 (0BA5)	Pump Setpoint	Pump Setpoint	Displays the PID Setpoint.	No signal output available	dep. on P1-02
U1-91 (0BA6) <7>	Pump Feedback	Pump Feedback	Displays the PID Feedback.	No signal output available	dep. on P1-02

## B.16 U: Monitors

No. (Addr. Hex)	Name	LCD Display	Description	Analog Output Level	Unit
U1-92 (0BA7)	Pump Status	Pump Status	Displays Pump Running Status. <b>U1-92=00000000</b> 	No signal output available	–
U1-93 (0BA8)	Total Setpoint Compensation	Total SP Comp.	Displays the total absolute Setpoint Compensation.	No signal output available	dep. on P1-02
U1-94 (0BA9)	Motor Speed	Motor Speed	Displays the absolute value of the output frequency (U1-02) converted to RPM.	No signal output available	1 RPM
U1-96 (0BAB) <6>	PI Auxiliary Control Feedback Level	PI Aux FB Level	Displays the PI Auxiliary Control Feedback Level (H3-□□ = 27).	N/A	Unit dep. on Q6-21 Res. dep. on Q6-22
U1-97 (0BAC)	Water Level	Water Level	Displays the amount of water above the water level sensor.	Full scale: 10 V = Q4-02	0.1 ft.
U1-98 (0BAD)	Suction Pressure	Suction Pressure	Displays the amount of suction pressure.	Full scale: 10 V = Q5-02	0.1 PSI or "Hg
U1-99 (0BAE) <7>	Anti-No-Flow Timer	ANF Timer	The Anti-No-Flow reduces the output frequency when this value reaches the P2-24 setting.	No signal output available	0.1 s

<1> Display is in the following units:

2A0004 to 2A0040, 4A0002 to 4A0023, and 5A0007 to 5A0017: 0.01 A units.

2A0056 to 2A0415, 4A0031 to 4A0675, and 5A0022 to 5A0242: 0.1 A units.

4A0930 and 4A1200: 1 A units.

<2> When reading the value of this monitor via MEMOBUS/Modbus, a value of 8192 is equal to 100% of the drive rated output current.

<3> Values shown are specific to 200 V class drives. Double the value for 400 V class drives. Multiply the value by 2.875 for 600 V class drives.

<4> The display resolution depends on the ND selection. This value has two decimal places (0.01 kW) if the drive is set for a maximum applicable motor capacity up to and including 11 kW, and one decimal place (0.1 kW) if the maximum applicable motor capacity is higher than 11 kW.

<5> Available in drive software versions PRG: 8551 and later.

<6> Available in drive software versions PRG: 8552 and later. Not available in drive models 4A0930 and 4A1200.

<7> Monitor is available through the Quick Monitor screen.

## ◆ U2: Fault Trace

No. (Addr. Hex)	Name	LCD Display	Description	Analog Output Level	Unit
U2-01 (0080)	Current Fault	Current Fault	Displays the current fault.	No signal output available	–
U2-02 (0081)	Previous Fault	Last Fault	Displays the previous fault.	No signal output available	–
U2-03 (0082)	Frequency Reference at Previous Fault	Frequency Ref	Displays the frequency reference at the previous fault.	No signal output available	0.01 Hz
U2-04 (0083)	Output Frequency at Previous Fault	Output Freq	Displays the output frequency at the previous fault.	No signal output available	0.01 Hz
U2-05 (0084)	Output Current at Previous Fault	Output Current	Displays the output current at the previous fault. <b>Note:</b> The unit is expressed in 1 A for models 4A0930 and 4A1200.	No signal output available	<1> <2>



No. (Addr. Hex)	Name	LCD Display	Description	Analog Output Level	Unit
U2-07 (0086)	Output Voltage at Previous Fault	Output Voltage	Displays the output voltage at the previous fault.	No signal output available	0.1 Vac
U2-08 (0087)	DC Bus Voltage at Previous Fault	DC Bus Voltage	Displays the DC bus voltage at the previous fault.	No signal output available	1 Vdc
U2-09 (0088)	Output Power at Previous Fault	Output kWatts	Displays the output power at the previous fault.	No signal output available	0.1 kW
U2-10 (0089)	Torque Reference at Previous Fault	Torque Reference	<b>OLV</b> Displays the torque reference at the previous fault.	No signal output available	0.1%
U2-11 (008A)	Input Terminal Status at Previous Fault	Input Term Sts	Displays the input terminal status at the previous fault. Displayed as in U1-10.	No signal output available	–
U2-12 (008B)	Output Terminal Status at Previous Fault	Output Term Sts	Displays the output status at the previous fault. Displays the same status displayed in U1-11.	No signal output available	–
U2-13 (008C)	Drive Operation Status at Previous Fault	Inverter Status	Displays the operation status of the drive at the previous fault. Displays the same status displayed in U1-12.	No signal output available	–
U2-14 (008D)	Cumulative Operation Time at Previous Fault	Elapsed time	Displays the cumulative operation time at the previous fault.	No signal output available	1 h
U2-15 (07E0)	Soft Starter Speed Reference at Previous Fault	SFS Output	Displays the speed reference for the soft starter at the previous fault.	No signal output available	0.01 Hz
U2-16 (07E1)	Motor q-Axis Current at Previous Fault	Motor Iq Current	Displays the q-axis current for the motor at the previous fault.	No signal output available	0.10%
U2-17 (07E2)	Motor d-Axis Current at Previous Fault	Motor Id Current	<b>OLV</b> Displays the d-axis current for the motor at the previous fault.	No signal output available	0.10%
U2-20 (008E)	Heatsink Temperature at Previous Fault	Actual Fin Temp	Displays the temperature of the heatsink when the most recent fault occurred.	No signal output available	1 °C
U2-27 (07FA)	Motor Temperature at Previous Fault (NTC)	Moter temp (NTC)	Displays the temperature of the motor when the most recent fault occurred. Displayed as in U4-32. <b>Note:</b> This monitor is only displayed in models 4A0930 and 4A1200.	No signal output available	1 °C
U2-28 (07FC)	Malfunctioned Module	Fault Axis	Display the module where the previous fault occurred at a decimal number. <b>Note:</b> This monitor is only displayed in models 4A0930 and 4A1200.	No signal output available	–
U2-30 (3008)	Date Year at Previous Fault	Date Year YYYY	Displays the year when the most recent fault occurred.	No signal output available	–
U2-31 (3009)	Date Month and Day at Previous Fault	Date Mo Day MMDD	Displays the date and day when the most recent fault occurred.	No signal output available	–
U2-32 (300A)	Time Hours and Minutes at Previous Fault	Time Hr Min HHMM	Displays the time when the most recent fault occurred.	No signal output available	–
U2-90 (3044) <3>	Pump Setpoint	Pump Setpoint	Displays the PID Setpoint at the time of fault.	Full scale: N/A	dep. on P1-02
U2-91 (3045) <3>	Pump Feedback	Pump Feedback	Displays the PID Feedback at the time of fault.	Full scale: N/A	dep. on P1-02
U2-94 (3048) <3>	Motor Speed	Motor Speed	Displays the absolute value of the output frequency (U1-02) converted to RPM at the time of fault.	Full scale: N/A	1 RPM
U2-97 (304B) <3>	Water Level	Water Level	Displays the amount of water above the water level sensor at the time of fault.	Full scale: N/A	0.1 ft.
U2-98 (304C) <3>	Suction Pressure	Suction Pressure	Displays the amount of suction pressure at the time of fault.	Full scale: N/A	0.1 PSI or “Hg

<1> Display is in the following units:  
 2A0004 to 2A0040, 4A0002 to 4A0023, and 5A0007 to 5A0017: 0.01 A units.  
 2A0056 to 2A0415, 4A0031 to 4A0675, and 5A0022 to 5A0242: 0.1 A units.  
 4A0930 and 4A1200: 1 A units.

## B.16 U: Monitors

<2> When reading the value of this monitor via MEMOBUS/Modbus, a value of 8192 is equal to 100% of the drive rated output current.

<3> Available in drive software versions PRG: 8552 and later. Not available in drive models 4A0930 and 4A1200.

### ◆ U3: Fault History

No. (Addr. Hex)	Name	LCD Display	Description	Analog Output Level	Unit
U3-01 (0800)	Last Fault	Last Fault	Displays the most recent fault.	No signal output available	–
U3-02 to U3-04 (90 to 93 (0801 to 0803))	Second to 4th Most Recent Fault	Fault Message <input type="checkbox"/>	Displays the second to the fourth most recent faults.	No signal output available	–
U3-05 to U3-10 (0804 to 0809)	5th to 10th Most Recent Fault	Fault Message <input type="checkbox"/>	Displays the fifth to the tenth most recent faults. After ten faults, data for the oldest fault is deleted. The most recent fault appears in U3-01, with the next most recent fault appearing in U3-02. The data is moved to the next monitor parameter each time a fault occurs.	No signal output available	–
U3-11 to U3-14 (94 to 97 (080A to 080D))	Cumulative Operation Time at 1st to 4th Most Recent Fault	Elapsed Time <input type="checkbox"/>	Displays the cumulative operation time when the first to the fourth most recent faults occurred.	No signal output available	1 h
U3-15 to U3-20 (080E to 0813)	Cumulative Operation Time at 5th to 10th Most Recent Fault	Elapsed Time <input type="checkbox"/>	Displays the cumulative operation time when the fifth to the tenth most recent faults occurred.	No signal output available	1 h
U3-21 (300B)	Date Year at Most Recent Fault	Fault 1 YYYY	Displays the year when the most recent fault occurred.	No signal output available	–
U3-22 (300C)	Date Month and Day at Most Recent Fault	Fault 1 MMDD	Displays the date and day when the most recent faults occurred.	No signal output available	–
U3-23 (300D)	Time Hours and Minutes at Most Recent Fault	Fault 1 HHMM	Displays the time when the most recent fault occurred.	No signal output available	–
U3-24 (300E)	Date Year at 2nd Most Recent Fault	Fault 2 YYYY	Displays the year when the second most recent fault occurred.	No signal output available	–
U3-25 (300F)	Date Month and Day at 2nd Most Recent Fault	Fault 2 MMDD	Displays the date and day when the second most recent fault occurred.	No signal output available	–
U3-26 (3010)	Time Hours and Minutes at 2nd Most Recent Fault	Fault 2 HHMM	Displays the time when the second most recent fault occurred.	No signal output available	–
U3-27 (3011)	Date Year at 3rd Most Recent Fault	Fault 3 YYYY	Displays the year when the most third recent fault occurred.	No signal output available	–
U3-28 (3012)	Date Month and Day at 3rd Most Recent Fault	Fault 3 MMDD	Displays the date and day when the third most recent fault occurred.	No signal output available	–
U3-29 (3013)	Time Hours and Minutes at 3rd Most Recent Fault	Fault 3 HHMM	Displays the time when the third most recent fault occurred.	No signal output available	–
U3-30 (3014)	Date Year at 4th Most Recent Fault	Fault 4 YYYY	Displays the year when the fourth most recent fault occurred.	No signal output available	–
U3-31 (3015)	Date Month and Day at 4th Most Recent Fault	Fault 4 MMDD	Displays the date and day when the fourth most recent fault occurred.	No signal output available	–
U3-32 (3016)	Time Hours and Minutes at 4th Most Recent Fault	Fault 4 HHMM	Displays the time when the fourth most recent fault occurred.	No signal output available	–
U3-33 (3017)	Date Year at 5th Most Recent Fault	Fault 5 YYYY	Displays the year when the fifth most recent fault occurred.	No signal output available	–
U3-34 (3018)	Date Month and Day at 5th Most Recent Fault	Fault 5 MMDD	Displays the date and day when the fifth most recent fault occurred.	No signal output available	–
U3-35 (3019)	Time Hours and Minutes at 5th Most Recent Fault	Fault 5 HHMM	Displays the time when the fifth most recent fault occurred.	No signal output available	–

No. (Addr. Hex)	Name	LCD Display	Description	Analog Output Level	Unit
U3-36 (301A)	Date Year at 6th Most Recent Fault	Fault 6 YYYY	Displays the year when the sixth most recent fault occurred.	No signal output available	–
U3-37 (301B)	Date Month and Day at 6th Most Recent Fault	Fault 6 MMDD	Displays the date and day when the sixth most recent fault occurred.	No signal output available	–
U3-38 (301C)	Time Hours and Minutes at 6th Most Recent Fault	Fault 6 HHMM	Displays the time when the sixth most recent fault occurred.	No signal output available	–
U3-39 (301D)	Date Year at 7th Most Recent Fault	Fault 7 YYYY	Displays the year when the seventh most recent fault occurred.	No signal output available	–
U3-40 (301E)	Date Month and Day at 7th Most Recent Fault	Fault 7 MMDD	Displays the date and day when the seventh most recent fault occurred.	No signal output available	–
U3-41 (301F)	Time Hours and Minutes at 7th Most Recent Fault	Fault 7 HHMM	Displays the time when the seventh most recent fault occurred.	No signal output available	–
U3-42 (3020)	Date Year at 8th Most Recent Fault	Fault 8 YYYY	Displays the year when the eighth most recent fault occurred.	No signal output available	–
U3-43 (3021)	Date Month and Day at 8th Most Recent Fault	Fault 8 MMDD	Displays the date and day when the eighth most recent fault occurred.	No signal output available	–
U3-44 (3022)	Time Hours and Minutes at 8th Most Recent Fault	Fault 8 HHMM	Displays the time when the eighth most recent fault occurred.	No signal output available	–
U3-45 (3023)	Date Year at 9th Most Recent Fault	Fault 9 YYYY	Displays the year when the ninth most recent fault occurred.	No signal output available	–
U3-46 (3024)	Date Month and Day at 9th Most Recent Fault	Fault 9 MMDD	Displays the date and day when the ninth most recent fault occurred.	No signal output available	–
U3-47 (3025)	Time Hours and Minutes at 9th Most Recent Fault	Fault 9 HHMM	Displays the time when the ninth most recent fault occurred.	No signal output available	–
U3-48 (3026)	Date Year at 10th Most Recent Fault	Fault 10 YYYY	Displays the year when the tenth most recent fault occurred.	No signal output available	–
U3-49 (3027)	Date Month and Day at 10th Most Recent Fault	Fault 10 MMDD	Displays the date and day when the tenth most recent fault occurred.	No signal output available	–
U3-50 (3028)	Time Hours and Minutes at 10th Most Recent	Fault 10 HHMM	Displays the time when the tenth most recent fault occurred.	No signal output available	–

#### ◆ U4: Maintenance Monitors

No. (Addr. Hex)	Name	LCD Display	Description	Analog Output Level	Unit
U4-01 (004C) </> <6>	Cumulative Operation Time	Drv Elapsed Time	Displays the cumulative operation time of the drive. The value for the cumulative operation time counter can be reset in parameter o4-01. Use parameter o4-02 to determine if the operation time should start as soon as the power is switched on or only while the Run command is present. The maximum number displayed is 99999, after which the value is reset to 0.	No signal output available	1 h
U4-02 (0075)	Number of Run Commands	RUN Cmd Counter	Displays the number of times the Run command is entered. Reset the number of Run commands using parameter o4-13. This value will reset to 0 and start counting again after reaching 65535.	No signal output available	1 Time
U4-03 (0067) <2>	Cooling Fan Operation Time	Fan Elapsed Time	Displays the cumulative operation time of the cooling fan. The default value for the fan operation time is reset in parameter o4-03. This value will reset to 0 and start counting again after reaching 99999.	No signal output available	1 h
U4-04 (007E)	Cooling Fan Maintenance	Fan Life Mon	Displays main cooling fan usage time as a percentage of its expected performance life. Parameter o4-03 can be used to reset this monitor. Replace the fan when this monitor reaches 90%.	No signal output available	1%

## B.16 U: Monitors

No. (Addr. Hex)	Name	LCD Display	Description	Analog Output Level	Unit
U4-05 (007C)	Capacitor Maintenance	Cap Life Mon	Displays main circuit capacitor usage time as a percentage of their expected performance life. Parameter o4-05 can be used to reset this monitor. Replace the capacitor when this monitor reaches 90%.	No signal output available	1%
U4-06 (07D6)	Soft Charge Bypass Relay Maintenance	ChgCirc Life Mon	Displays the soft charge bypass relay maintenance time as a percentage of its estimated performance life. Parameter o4-07 can be used to reset this monitor. Replace the soft charge bypass relay when this monitor reaches 90%.	No signal output available	1%
U4-07 (07D7)	IGBT Maintenance	IGBT Life Mon	Displays IGBT usage time as a percentage of the expected performance life. Parameter o4-09 can be used to reset this monitor. Replace the IGBT when this monitor reaches 90%.	No signal output available	1%
U4-08 (0068)	Heatsink Temperature	Heatsink Temp	Displays the heatsink temperature.	10 V: 100 °C	1 °C
U4-09 (005E)	LED Check	LED Oper Check	Lights all segments of the LED to verify that the display is working properly. Press the ENTER key to turn the LEDs on and press ESC to turn the LEDs off.	No signal output available	–
U4-10 (005C)	kWh, Lower 4 Digits	kWh Lower 4 dig	Monitors the drive output power usage (or consumption). The value is shown as a 9-digit number displayed across two monitor parameters, U4-10 and U4-11. Example: 12345678.9 kWh is displayed as: U4-10: 678.9 kWh U4-11: 12345 MWh	No signal output available	0.1 kWh
U4-11 (005D)	kWh, Upper 5 Digits	kWh Upper 5 dig		No signal output available	1 MWh
U4-13 (07CF)	Peak Hold Current	Current PeakHold	Displays the highest current value that occurred during run. <b>Note:</b> The unit is expressed in 1 A for models 4A0930 and 4A1200.	No signal output available	0.01 A <> <> <>
U4-14 (07D0)	Peak Hold Output Frequency	Freq@ I PeakHold	Displays the output frequency when the current value shown in U4-13 occurred.	No signal output available	0.01 Hz
U4-16 (07D8)	Motor Overload Estimate (oL1)	Motor OL1 Level	Shows the value of the motor overload detection accumulator. 100% is equal to the oL1 detection level.	10 V: 100%	0.1%
U4-18 (07DA)	Frequency Reference Source Selection	Reference Source	Displays the source for the frequency reference as XY-nn. <b>X: indicates which reference is used:</b> 1 = Reference 1 (b1-01) 2 = Reference 2 (b1-15) <b>Y-nn: indicates the reference source</b> 0-01 = Digital operator 1-00 = Analog (Not displayed in models 4A0930 and 4A1200) 1-01 = Analog (terminal A1) 1-02 = Analog (terminal A2) 1-03 = Analog (terminal A3) 2-02 to 17 = Multi-step speed (d1-02 to 17) 3-01 = MEMOBUS/Modbus communications 4-01 = Communication option card 5-01 = Pulse input 9-01 = Up/Down Command (Not displayed in models 4A0930 and 4A1200)	No signal output available	–
U4-19 (07DB)	Frequency Reference from MEMOBUS/ Modbus Comm.	MEMOBUS Freq Ref	Displays the frequency reference provided by MEMOBUS/ Modbus (decimal).	No signal output available	0.01%
U4-20 (07DC)	Option Frequency Reference	Option Freq Ref	Displays the frequency reference input by an option card (decimal).	No signal output available	–

No. (Addr. Hex)	Name	LCD Display	Description	Analog Output Level	Unit
U4-21 (07DD)	Run Command Source Selection	Run Cmd Source	Displays the source for the Run command as XY-nn. <b>X: Indicates which Run source is used:</b> 1 = Reference 1 (b1-02) <b>Y: Input power supply data</b> 0 = Digital operator 1 = External terminals 3 = MEMOBUS/Modbus communications 4 = Communication option card <b>nn: Run command limit status data</b> 00: No limit status. 01: Run command was left on when stopped in the PRG mode 02: Run command was left on when switching from LOCAL to REMOTE operation 03: Waiting for soft charge bypass contactor after power up (Uv or Uv1 flashes after 10 s) 04: Waiting for “Run command prohibited” time period to end 05: Fast Stop (digital input, digital operator) 06: b1-17 (Run command given at power-up) 07: During baseblock while coast to stop with timer 08: Frequency reference is below minimal reference during baseblock 09: Waiting for Enter command	No signal output available	–
U4-22 (07DE)	MEMOBUS/Modbus Communications Reference	MEMOBUS Ref Reg	Displays the drive control data set by MEMOBUS/Modbus communications register no. 0001H as a four-digit hexadecimal number.	No signal output available	–
U4-23 (07DF)	Communication Option Card Reference	Option Ref Reg	Displays drive control data set by an option card as a four-digit hexadecimal number.	No signal output available	–
U4-32 (07FB)	Motor Temperature (NTC)	Motor Temperature (NTC)	Displays the motor temperature (NTC). U4-32 will display “20 °C” when a multi-function analog input is not set for motor thermistor input (H1-□□ = 17H). Monitor is only present when a digital input is programmed for 17 (Thermistor Input). <b>Note:</b> This monitor is only displayed in models 4A0930 and 4A1200.	200 °C	1 °C
U4-37 (1044)	oH Alarm Location Monitor	OH Alarm Axis	Displays the module where the oH alarm occurred as a binary number. <b>Note:</b> This monitor is only displayed in models 4A0930 and 4A1200.	No signal output available	–
U4-38 (1045)	FAn Alarm Location Monitor	FAN Alarm Axis	Displays the module where the FAn alarm occurred as a binary number. <b>Note:</b> This monitor is only displayed in models 4A0930 and 4A1200.	No signal output available	–
U4-39 (1046)	voF Alarm Location Monitor	VOF Alarm Axis	Displays the module where the voF alarm occurred as a binary number. <b>Note:</b> This monitor is only displayed in models 4A0930 and 4A1200.	No signal output available	–

- <1> The MEMOBUS/Modbus communications data is in 10 h units. If data in 1 h units are also required, refer to register number 0099H.
- <2> The MEMOBUS/Modbus communications data is in 10 h units. If data in 1 h units are also required, refer to register number 009BH.
- <3> Display is in the following units:  
2A0004 to 2A0040, 4A0002 to 4A0023, and 5A0007 to 5A0017: 0.01 A units.  
2A0056 to 2A0415, 4A0031 to 4A0675, and 5A0022 to 5A0242: 0.1 A units.  
4A0930 and 4A1200: 1 A units.
- <4> The values of U1-03, U2-05, and U4-13 are displayed on the digital operator in units of amperes. When those monitors are checked using MEMOBUS/Modbus communications, the monitor values in MEMOBUS/Modbus communications are displayed as: numeric value / 8192 × drive rated current (A) from the condition “192 (maximum value) = drive rated current (A)”
- <5> When reading the value of this monitor via MEMOBUS/Modbus a value of 8192 is equal to 100% of the drive rated output current.
- <6> Monitor is available through the Quick Monitor screen.

**◆ U5: PID Monitors**

No. (Addr. Hex)	Name	LCD Display	Description	Analog Output Level	Unit
U5-01 (0057)	PID Feedback 1	PID Feedback 1	Displays the PID feedback value.	10 V: 100%	0.1 PSI <1>
U5-02 (0063)	PID Input	PID Input	Displays the amount of PID input (deviation between PID setpoint and feedback).	10 V: 100%	0.01%
U5-03 (0064)	PID Output	PID Output	Displays PID control output.	10 V: 100%	0.01%
U5-04 (0065)	PID Setpoint	PID Setpoint	Displays the PID setpoint.	10 V: 100%	0.1 PSI <1>
U5-05 (07D2)	PID Differential Feedback	PID Feedback 2	Displays the 2nd PID feedback value if differential feedback is used (H3-□□ = 16).	10 V: 100%	0.01%
U5-06 (07D3)	PID Adjusted Feedback	PID Diff Fdbk	Displays the difference of both feedback values if differential feedback is used (U5-01 - U5-05). If differential feedback is not used, then U5-01 and U5-06 will be the same.	10 V: 100%	0.01%
U5-14 (086B)	PI Output 2 Upper 4 Digits	PI Output2 U4	Displays the custom PI output. U5-14 shows the upper 4 digits while U5-15 shows the lower 4 digits. Monitors are scaled by b5-43 and b5-44.	No signal output available	1 <2>
U5-15 (086C)	PI Output 2 Lower 4 Digits	PI Output2 L4	Displays the custom PI output. U5-14 shows the upper 4 digits while U5-15 shows the lower 4 digits. Monitors are scaled by b5-43 and b5-44.	No signal output available	0.01 <2>
U5-17 (086E)	PI2 Setpoint	PI2 Setpoint	Displays the secondary PI setpoint.	Dependent upon S3-02	<3>
U5-18 (086F)	PI2 Feedback	PI2 Feedback	Displays the secondary PI feedback value.	Dependent upon S3-02	<3>
U5-19 (0870)	PI2 Input	PI2 Input	Displays the secondary PI input (deviation between PI target and feedback).	Dependent upon S3-02	<3>
U5-20 (0871)	PI2 Output	PI2 Output	Displays the secondary PI control output.	Dependent upon S3-02	<3>
U5-30 (3000)	Time Hr Min HHMM	Time Hr Min HHMM	Displays the current time (Hours and Minutes).	No signal output available	1
U5-31 (3001)	Date Year	Date Year	Displays the current year.	No signal output available	1
U5-32 (3002)	Date Mo Day MMDD	Date Mo Day MMDD	Displays the current date (Month and Day).	No signal output available	1
U5-33 (3003)	Date Week 000W	Date Week 0: Sunday 1: Monday 2: Tuesday 3: Wednesday 4: Thursday 5: Friday 6: Saturday	Displays the current date of the week. 0: Sunday 1: Monday 2: Tuesday 3: Wednesday 4: Thursday 5: Friday 6: Saturday	No signal output available	1
U5-99 (1599)	AUTO Setpoint	Auto Setpoint	Displays the PID Setpoint commanded by the source when the drive is in AUTO Mode.	No signal output available	0.1 PSI <1>

<1> Unit, range and resolution is determined by b5-20, b5-38, b5-39, and b5-46

<2> Unit is determined by b5-41

<3> Unit is determined by S3-04.

## ◆ U6: Operation Status Monitors

No. (Addr. Hex)	Name	LCD Display	Description	Analog Output Level	Unit
U6-01 (0051)	Motor Secondary Current (Iq)	Mot SEC Current	Displays the value of the motor secondary current (Iq). Motor rated secondary current is 100%.	10 V: Motor secondary rated current	0.1%
U6-02 (0052)	Motor Excitation Current (Id)	Mot EXC Current	<b>OLV</b> Displays the value calculated for the motor excitation current (Id). Motor rated secondary current is 100%.	10 V: Motor secondary rated current	0.1%
U6-05 (0059)	Output Voltage Reference (Vq)	Voltage Ref (Vq)	<b>OLV</b> Output voltage reference (Vq) for the q-Axis.	10 V: 200 Vrms </>	0.1 Vac
U6-06 (005A)	Output Voltage Reference (Vd)	Voltage Ref (Vd)	<b>OLV</b> Output voltage reference (Vd) for the d-Axis.	10 V: 200 Vrms </>	0.1 Vac
U6-07 (005F)	q-Axis ACR Output	ACR(q) Output	<b>OLV</b> Displays the output value for current control relative to motor secondary current (q-Axis).	10 V: 200 Vrms </>	0.1%
U6-08 (0060)	d-Axis ACR Output	ACR(d) Output	<b>OLV</b> Displays the output value for current control relative to motor secondary current (d-Axis).	110 V: 200 Vrms </>	0.1%

<1> Values shown are specific to 200 V class drives. Double the values for 400 V class drives. Multiply the values by 2.875 for 600 V class drives.

**Note:** Fault histories are not kept when CPF00, CPF01, CPF06, CPF24, oFA00, oFb00, oFC00, Uv1, Uv2, or Uv3 occur.

## ◆ U7: CASE Monitors

No. (Addr. Hex)	Name	LCD Display	Description	Analog Output Level	Unit
U7-01 (0051)	CASE Software Number	CASE Software #	Displays the CASE software version number.	No signal output available	–

## ◆ U9: Operation Status Monitors

No. (Addr. Hex)	Name	LCD Display	Description	Analog Output Level	Unit
U9-01 (1901)	Network PI Feedback	Net PI Feedback	Displays the network PI feedback recognized by the iQpump MEMOBUS network.	No signal output available	Dep. on P1-02
U9-02 (1902) <2>	Network Activity	iQ Net Activity	Displays network traffic. A fluctuating number from 0 to 10000 denotes activity, while a relatively constant 0 denotes no activity.	No signal output available	</>
U9-03 (1903) <2>	Time to Alternate	Time to Alternate	Displays the time remaining before a drive requests the alternation mode set in P9-04.	No signal output available	min
U9-04 (1904)	Running Queue Number	Running Queue No	Displays the position in the iQpump MEMOBUS Multiplex running queue.	No signal output available	–

<1> Unit changes based on network status.

<->: Drive cannot communicate to other drives

<+>: Drive is a node on a network

<M>: Drive is the master on an iQpump network.

<2> Monitor is available through the Quick Monitor screen.

**This Page Intentionally Blank**



# Appendix: C

## **MEMOBUS/Modbus Communications**

---

<b>C.1</b>	<b>MEMOBUS/MODBUS CONFIGURATION.....</b>	<b>450</b>
<b>C.2</b>	<b>COMMUNICATION SPECIFICATIONS.....</b>	<b>451</b>
<b>C.3</b>	<b>CONNECTING TO A NETWORK.....</b>	<b>452</b>
<b>C.4</b>	<b>MEMOBUS/MODBUS SETUP PARAMETERS.....</b>	<b>455</b>
<b>C.5</b>	<b>DRIVE OPERATIONS BY MEMOBUS/MODBUS.....</b>	<b>459</b>
<b>C.6</b>	<b>COMMUNICATIONS TIMING.....</b>	<b>460</b>
<b>C.7</b>	<b>MESSAGE FORMAT.....</b>	<b>461</b>
<b>C.8</b>	<b>MESSAGE EXAMPLES.....</b>	<b>463</b>
<b>C.9</b>	<b>MEMOBUS/MODBUS DATA TABLE.....</b>	<b>465</b>
<b>C.10</b>	<b>ENTER COMMAND.....</b>	<b>483</b>
<b>C.11</b>	<b>COMMUNICATION ERRORS.....</b>	<b>484</b>
<b>C.12</b>	<b>SELF-DIAGNOSTICS.....</b>	<b>485</b>

### C.1 MEMOBUS/Modbus Configuration

Drives can be controlled from a PLC or other master device via serial communications using the MEMOBUS/Modbus protocol. MEMOBUS/Modbus communications can be configured using one master (PLC) and up to 255 slaves. The drive has slave functionality only, and serial communication is normally initiated from the master and responded to by the slaves.

The master communicates with the specified slave drive. The address or node for each slave must be set prior so the master can communicate with the slave at that address. A slave that receives a command from the master will perform the specified function and send a response back to the master.

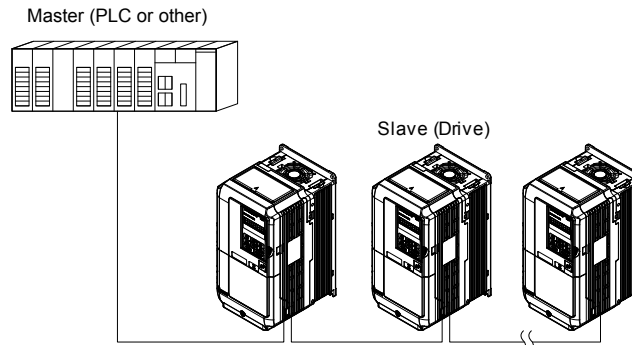

Figure C.1 Connecting Multiple Drives to a PLC

## C.2 Communication Specifications

MEMOBUS/Modbus specifications appear in [Table C.1](#):

**Table C.1 MEMOBUS/Modbus Communications Specifications**

Item	Specifications	
Interface	RS-422, RS-485	
Communications Cycle	Asynchronous (Start-stop synchronization)	
Communication Parameters	Communication Speeds Available	1.2; 2.4; 4.8; 9.6; 19.2; 38.4; 57.6; 76.8; 115.2 kbps
	Data length	8-bit (fixed)
	Parity	Select even, odd, or none
	Stop bit	1-bit (fixed)
Protocol	MEMOBUS/Modbus (using RTU mode only)	
Maximum Number of Slaves	31 drives (RS-485)	

### C.3 Connecting to a Network

This section explains how to connect the drive to a MEMOBUS/Modbus network and the network termination required for a connection.

#### ◆ Network Cable Connection

Follow the instructions below to connect the drive to a MEMOBUS/Modbus network.

1. With the power shut off, connect the communications cable to the drive and the master. Use terminals TB5 for MEMOBUS/Modbus.

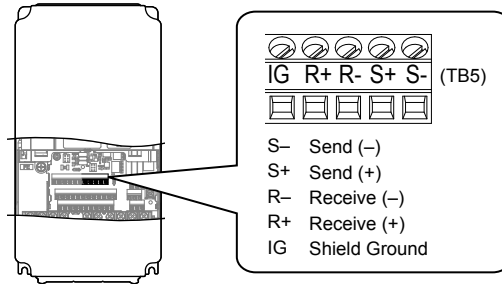

**Figure C.2 Serial Communications Cable Connection Terminals (TB5)**

**Note:** Separate the communications cables from the main circuit cables and other wiring and power cables. Use shielded cables for the communications cables, and properly shielded clamps to prevent problems with noise. When using RS-485 communications, connect S+ to R+, and S- to R- as shown in the diagram below.

2. Check or set the termination resistor selection at all slaves. Use the description in [Network Termination](#) on page 454 for slaves that are iQpump drives.
3. Switch the power on.
4. Set the parameters needed for serial communications (H5-01 through H5-12) using the digital operator.
5. Shut the power off and wait until the display on the digital operator goes out completely.
6. Turn the power back on.
7. The drive is now ready to begin communicating with the master.

## ◆ Wiring Diagram for Multiple Connections

*Figure C.3* and *Figure C.4* explain the wiring diagrams for multiple connections using MEMOBUS/Modbus communication.

### ■ RS-485 Interface

**Note:** The isolated ground (IG) connection is optional but strongly recommended to improve network immunity to electrical interference.

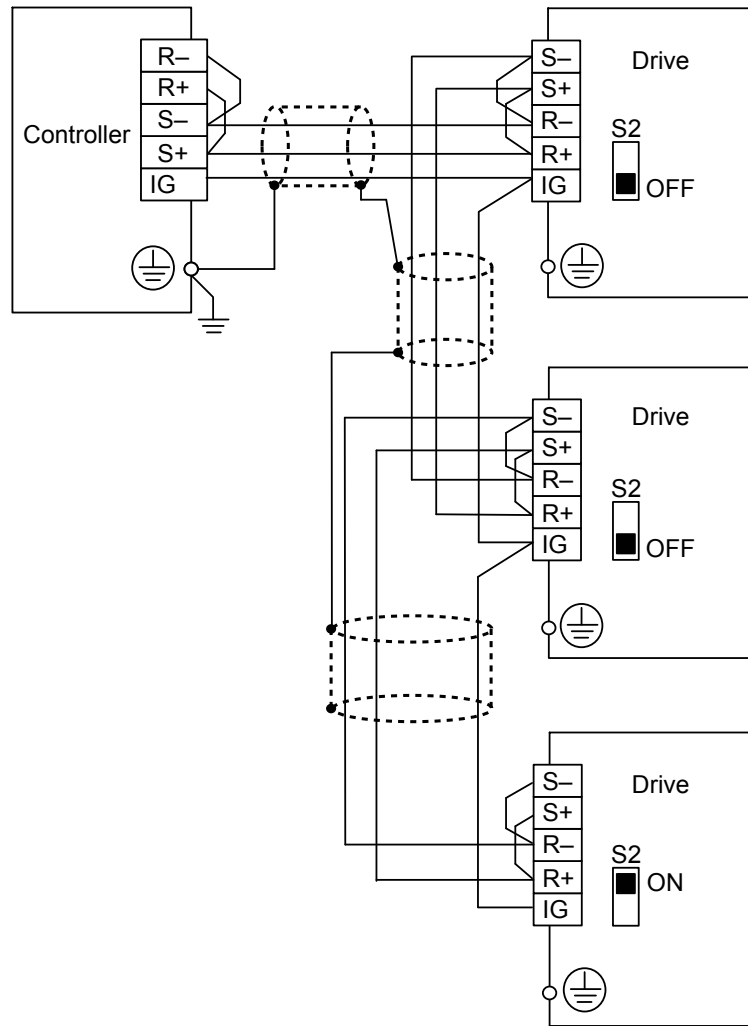

**Figure C.3 RS-485 Interface**

- Note:**
1. Set DIP switch S2 to the ON position on the drive located at the end of the network. Set DIP switch S2 to the OFF positions on all other slave devices.
  2. Set H5-07 to 1 when using the RS-485 interface.

### ■ RS-422 Interface

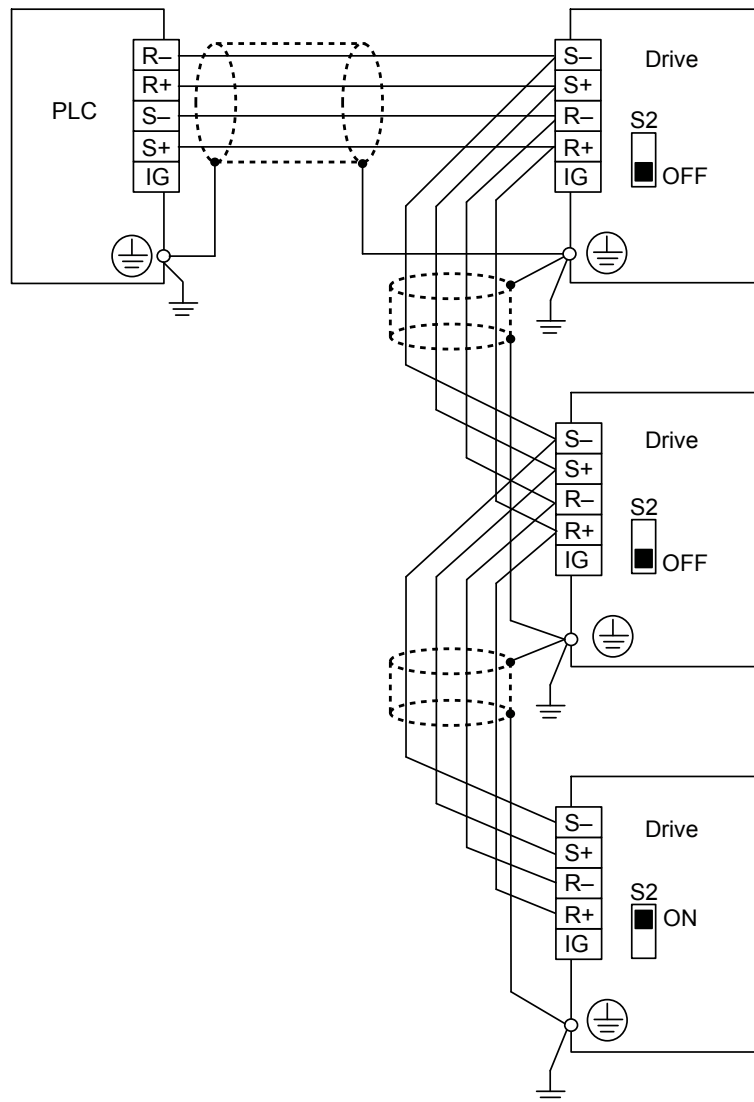

Figure C.4 RS-422 Interface

- Note:**
1. Set DIP switch S2 to the ON position on the drive located at the end of the network. Set DIP switch S2 to the OFF positions on all other slave devices.
  2. Set H5-07 to 1 when using the RS-422 interface in a multi-drop circuit.  
Set H5-07 to 0 when using the RS-422 interface in a point-to-point circuit.

### ◆ Network Termination

The two ends of the MEMOBUS/Modbus network line have to be terminated. The drive has a built in termination resistor that can be enabled or disabled using DIP switch S2. If a drive is located at the end of a network line, enable the termination resistor by setting DIP switch S2 to the ON position. Disable the termination resistor on all slaves that are not located at the network line end.

## C.4 MEMOBUS/Modbus Setup Parameters

### ◆ MEMOBUS/Modbus Serial Communication

Changes to MEMOBUS/Modbus communications settings become effective after restarting the drive.

#### ■ H5-01: Drive Node Address

Sets the drive station node number (address) for MEMOBUS/Modbus terminals R+, R-, S+, S- . .

**Note:** Cycle the power after changing this parameter to enable the new setting.

No.	Name	Setting Range	Default
H5-01	Drive Slave Address	0 to FF	1F (Hex)

Each slave drive must be assigned a unique slave address for serial communications to work. Setting H5-01 to any value besides 0 assigns the drive its address in the network. Slave addresses do not need to be assigned in sequential order, but no two drives may share the same address.

#### ■ H5-02: Communication Speed Selection

Sets the MEMOBUS/Modbus communications speed.

**Note:** Cycle the power after changing this parameter to enable the new setting.

No.	Name	Setting Range	Default
H5-02	Communication Speed Selection	0 to 8	3

H5-02	Communication Speed	H5-02	Communication Speed
0	1200 bps	5	38400 bps
1	2400 bps	6	57600 bps
2	4800 bps	7	76800 bps
3	9600 bps	8	115200 bps
4	19200 bps		

#### ■ H5-03: Communication Parity Selection

Sets the parity used for communications.

**Note:** Cycle power for the setting to take effect.

No.	Name	Setting Range	Default
H5-03	Communication Parity Selection	0 to 2	0

**Setting 0: No parity**

**Setting 1: Even parity**

**Setting 2: Odd parity**

#### ■ H5-04: Stopping Method after Communication Error

Selects the stopping method after a communications error (CE) has occurred.

No.	Name	Setting Range	Default
H5-04	Stopping Method after CE	0 to 4	3

**Setting 0: Ramp to stop (uses the deceleration time currently enabled)**

**Setting 1: Cost to stop**

**Setting 2: Fast Stop**

**Setting 3: Alarm only (continue operation)**

**Setting 4: Run at H5-14**

**Note:**

1. This setting is available in drive software versions PRG: 8552 and later.
2. This setting is not available in drive models 4A0930 and 4A1200.

This setting will trigger a “CE – Comm Loss” alarm and cause the drive to run at the speed set in H5-14 speed when a Communication Error (CE) occurs.

## C.4 MEMOBUS/Modbus Setup Parameters

The drive faults on CE and coasts to stop when H5-15 > 0 and the CE condition persists for the time set in H5-15.

Note the following conditions when using this setting and a CE occurs:

- During Pre-charge, the drive will continue to run at the Pre-charge frequency
- During Sleep, the drive will wake up and run at the speed set in H5-14
- During Feedback Drop, the drive will wake up and run at the speed set in H5-14
- Lag pumps are deactivated when in Contactor Multiplex.

### ■ H5-05: Communication Fault Detection Selection

Enables or disables the CE detection for communications.

No.	Name	Setting Range	Default
H5-05	Communication Fault Detection Selection	0 or 1	1

#### Setting 0: Disabled

No communication error detection. The drive continues operation.

#### Setting 1: Enabled

If the drive does not receive data from the master for longer than the time set to H5-09, then a CE fault will be triggered and the drive will operate as determined by parameter H5-04.

### ■ H5-06: Drive Transmit Wait Time

Sets the time the drive waits after receiving data from a master until responding data.

**Note:** Cycle power for the setting to take effect.

No.	Name	Setting Range	Default
H5-06	Drive Transmit Wait Time	5 to 65 ms	5 ms

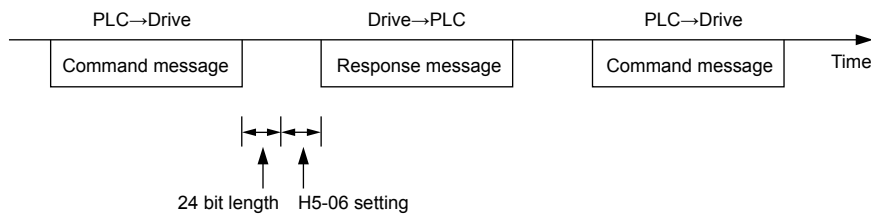

Figure C.5 Drive Transmit Wait Time Setting

### ■ H5-07: RTS Control Selection

Enables or disables RTS control.

**Note:** Cycle power for the setting to take effect.

No.	Name	Setting Range	Default
H5-07	RTS Control Selection	0 or 1	1

#### Setting 0: Disabled. RTS is always on.

Use this setting with point-to-point RS-422 communications.

#### Setting 1: Enabled. RTS switches while sending.

Use this setting with RS-485 communications or when using multi-drop RS-422 communications.

### ■ H5-09: Communications Fault Detection Time

Sets the time the communications must be lost before the drive triggers a CE fault.

No.	Name	Setting Range	Default
H5-09	Communications Fault Detection Time	0.0 to 10.0 s	2.0 s



■ **H5-10: Unit Selection for MEMOBUS/Modbus Register 0025H**

Sets the unit for the output voltage monitor value in MEMOBUS/Modbus register 0025H.

No.	Name	Setting Range	Default
H5-10	Unit Selection for MEMOBUS/Modbus Register 0025H	0 or 1	0

**Setting 0: 0.1 V units**

**Setting 1: 1 V units**

■ **H5-11: Communications Enter Function Selection**

Selects whether an Enter command is necessary to change parameter values via MEMOBUS/Modbus communications. *Refer to Enter Command on page 483.*

No.	Name	Setting Range	Default
H5-11	Communications Enter Function Selection	0 or 1	0

**Setting 0: Enter command necessary**

Parameter changes become effective after an Enter command. An Enter command must only be sent after the last parameter change, not for each single parameter.

**Setting 1: Enter command not necessary**

Parameter value changes become effective immediately without the need to send an Enter command.

■ **H5-12: Run Command Method Selection**

Selects the type of sequence used when the Run command source is set to MEMOBUS/Modbus communications (b1-02, b1-16 = 2).

No.	Name	Setting Range	Default
H5-12	Run Command Method Selection	0 or 1	0

**Setting 0: FWD/Stop, REV/Stop**

Setting bit 0 of MEMOBUS/Modbus register 0001H will start and stop the drive in the forward direction. Setting bit 1 will start and stop the drive in reverse.

**Setting 1: Run/Stop, FWD/REV**

Setting bit 0 of MEMOBUS/Modbus register 0001H will start and stop the drive. Setting bit 1 changes the direction.

■ **H5-14: Communication Error (CE) Go-To-Frequency**

- Note:**
1. This parameter is available in drive software versions PRG: 8552 and later.
  2. This parameter is not available in drive models 4A0930 and 4A1200.

Sets the speed at which the drive will run when H5-04 = 4 and a CE is present.

No.	Name	Setting Range	Default
H5-14	Communication Error (CE) Go-To-Frequency	0.0 to 400.0 Hz	0.0 Hz

■ **H5-15: Communication Error (CE) Go-To-Timeout**

Sets the time for which the drive will run at the speed set in H5-14 when H5-04 = 4 (Run at H5-14) before triggering a CE fault.

Setting this parameter to 0 will disable the timeout.

- Note:**
1. This parameter is available in drive software versions PRG: 8552 and later.
  2. This parameter is not available in drive models 4A0930 and 4A1200.

No.	Name	Setting Range	Default
H5-15	Communication Error (CE) Go-To-Timeout	0 to 6000 s	0 s

■ **H5-16: Communication Error Fault Restart Selection**

Determines whether the CE fault can be restarted.

- Note:**
1. This parameter is available in drive software versions PRG: 8552 and later.
  2. This parameter is not available in drive models 4A0930 and 4A1200.

## C.4 MEMOBUS/Modbus Setup Parameters

---

No.	Name	Setting Range	Default
H5-16	Communication Error Fault Restart Selection	0 to 3	3

**Setting 0: No retry**

**Setting 1: Retry**

## C.5 Drive Operations by MEMOBUS/Modbus

The drive operations that can be performed by MEMOBUS/Modbus communication depend on drive parameter settings. This section explains the functions that can be used and related parameter settings.

### ◆ Observing the Drive Operation

PLCs can perform the following actions with MEMOBUS/Modbus communications:

- observe drive status and drive control terminal status
- read and write parameters (not H5-□□)
- reset faults
- set multi-function inputs

**Note:** Input settings from the input terminals (S1 to S8) and from MEMOBUS/Modbus communications are both linked by a logical OR operation.

### ◆ Controlling the Drive

Select an external reference and adjust the parameters in [Table C.2](#) accordingly to start and stop the drive or set the frequency reference using MEMOBUS/Modbus communications.

**Table C.2 Setting Parameters for Drive Control from MEMOBUS/Modbus**

Reference Source	Parameter	Name	Required Setting
External Reference 1	b1-01	Frequency Reference Selection 1	2
	b1-02	Run Command Selection 1	2
External Reference 2	b1-15	Frequency Reference Selection 2	2
	b1-16	Run Command Selection 2	2

*Refer to b1-01: Frequency Reference Selection 1 on page 214 and Refer to b1-02: Run Command Selection 1 on page 217 for details on external reference parameter selections.*

## C.6 Communications Timing

To prevent a communications overrun in the slave drive, the master should wait a certain time between sending messages to the same drive. In the same way, the slave drive must wait before sending response messages to prevent an overrun in the master. This section explains the message timing.

### ◆ Command Messages from Master to Drive

The master must wait for a specified time between receiving a response and resending the same type of command to the same slave drive to prevent overrun and data loss. The minimum wait time depends on the command as shown in [Table C.3](#).

**Table C.3 Minimum Wait Time for Sending Messages**

Command Type	Example	Minimum Wait Time
1	<ul style="list-style-type: none"> <li>Control command (Run, Stop)</li> <li>Set inputs/outputs</li> <li>Read monitors and parameter values</li> </ul>	5 ms </>
2	Write parameters	H5-11 = 0: 50 ms H5-11 = 1: 200 ms </>
3	Save changes using an Enter command	200 ms to 2 s, depending on the number of parameters that were changed </>
4	Enter with storage to drive EEPROM after initialization	5 s

<1> If the drive receives command type 1 data during the minimum wait time, it will perform the command and then respond. However, if it receives a command type 2 or 3 during that time, either a communication error will result or the command will be ignored.

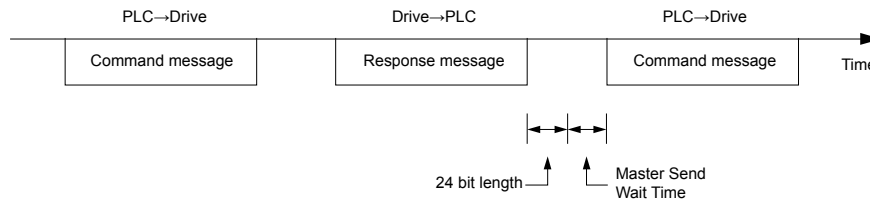
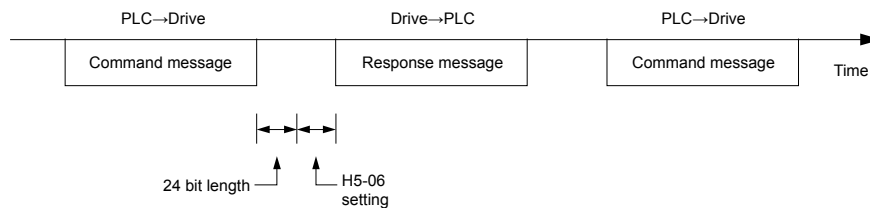

**Figure C.6 Minimum Wait Time for Sending Messages**

Set a timer in the master to check how long it takes for the slave drive(s) to respond to the master. If no response is received within a certain amount of time, the master should try resending the message.

### ◆ Response Messages from Drive to Master

If the drive receives a command from the master, it will process the data received and wait for the time set in H5-06 until it responds. Increase H5-06 if the drive response causes overrun in the master.



**Figure C.7 Minimum Response Wait Time**

## C.7 Message Format

### ◆ Message Content

In MEMOBUS/Modbus communications, the master sends commands to the slave, and the slave responds. The message format is configured for both sending and receiving as shown below, and the length of data packets depends on the command (function) content.

SLAVE ADDRESS
FUNCTION CODE
DATA
ERROR CHECK

### ◆ Slave Address

The slave address in the message defines the note the message is sent to. Use addresses between 0 and FF (hex). If a message with slave address 0 is sent (broadcast), the command from the master will be received by all slaves. The slaves do not provide a response to a broadcast type message.

### ◆ Function Code

The three types of function codes are shown in the table below.

Function Code	Function Name	Data Length (bytes)			
		Command Message		Response Message	
		Minimum	Maximum	Minimum	Maximum
03H	Read MEMOBUS/Modbus registers	8	8	7	37
08H	Loopback test	8	8	8	8
10H	Write to multiple MEMOBUS/Modbus registers	11	41	8	8

### ◆ Data

Configure consecutive data by combining the MEMOBUS/Modbus register address (test code in case of a loopback test) and the data the register contains. The data length changes depending on the command details.

A drive MEMOBUS/Modbus register always has a data length of two bytes. Data written into drive registers must also always have a length of two bytes. Register data read out from the drive will always consist of two bytes.

### ◆ Error Check

The drive uses a CRC-16 (cyclic redundancy check, checksum method) for checking data validity. Use the procedure described below when calculating the CRC-16 checksum for command data or when verifying response data.

#### ■ Command Data

When the drive receives data, it calculates the CRC-16 checksum from the data and compares it to the CRC-16 value received within the message. Both must match before a command is processed.

An initial value of FFFFH (i.e., all 16 bits equal 1) must be used for CRC-16 calculations in the MEMOBUS/Modbus protocol.

Calculate the CRC-16 checksum using the following steps:

1. The starting value is FFFFH.
2. Perform an XOR operation of this value and the slave address.
3. Right shift the result.
4. When the overflow bit of the shift operation becomes 1, perform an XOR operation of the result from step 3 above and the fix value A001H.
5. Repeat steps 3 and 4 until eight shift operations have been performed.
6. After eight shift operations, perform an XOR operation with the result and the next data in the message (function code, register address, data). Continue with steps 3 to 5 until the last data has been processed.
7. The result of the last shift or XOR operation is the checksum.

## C.7 Message Format

The example in [Table C.4](#) shows the CRC-16 calculation of the slave address 02H and the function code 03H, yielding the result D140H.

**Note:** This example does not show the calculation for a complete MEMOBUS/Modbus command. Normally data would follow in the calculation.

**Table C.4 CRC-16 Checksum Calculation Example**

Description	Calculation	Overflow	Description	Calculation	Overflow
Initial Value (FFFFH)	1111 1111 1111 1111		Function Code 03H	0000 0000 0000 0011	
Address 02H	0000 0000 0000 0010		XOR w result	1000 0001 0011 1101	
XOR w initial value	1111 1111 1111 1101		Shift 1	0100 0000 1001 1110	1
Shift 1	0111 1111 1111 1110	1	XOR w A001H	1010 0000 0000 0001	
XOR w A001H	1010 0000 0000 0001		XOR result	1110 0000 1001 1111	
XOR result	1101 1111 1111 1111		Shift 2	0111 0000 0100 1111	1
Shift 2	0110 1111 1111 1111	1	XOR w A001H	1010 0000 0000 0001	
XOR w A001H	1010 0000 0000 0001		XOR result	1101 0000 0100 1110	
XOR result	1100 1111 1111 1110		Shift 3	0110 1000 0010 0111	0
Shift 3	0110 0111 1111 1111	0	Shift 4	0011 0100 0001 0011	1
Shift 4	0011 0011 1111 1111	1	XOR w A001H	1010 0000 0000 0001	
XOR w A001H	1010 0000 0000 0001		XOR result	1001 0100 0001 0010	
XOR result	1001 0011 1111 1110		Shift 5	0100 1010 0000 1001	0
Shift 5	0100 1001 1111 1111	0	Shift 6	0010 0101 0000 0100	1
Shift 6	0010 0100 1111 1111	1	XOR w A001H	1010 0000 0000 0001	
XOR w A001H	1010 0000 0000 0001		XOR result	1000 0101 0000 0101	
XOR result	1000 0100 1111 1110		Shift 7	0100 0010 1000 0010	1
Shift 7	0100 0010 0111 1111	0	XOR w A001H	1010 0000 0000 0001	
Shift 8	0010 0001 0011 1111	1	XOR result	1110 0010 1000 0011	
XOR w A001H	1010 0000 0000 0001		Shift 8	0111 0001 0100 0001	1
XOR result	1000 0001 0011 1110		XOR w A001H	1010 0000 0000 0001	
Perform operations with next data (function code)			XOR result	1101 0001 0100 0000	
			CRC-16	1101 0001 0100 0000	
				D 1 4 0 (Lower) (Upper)	
Continue from here with next data.					

### ■ Response Data

Perform a CRC-16 calculation on the response message data as described above as a validation check. The result should match the CRC-16 checksum received within the response message.

## C.8 Message Examples

Below are some examples of command and response messages.

### ◆ Reading Drive MEMOBUS/Modbus Register Contents

Using the function code 03H (Read), a maximum of 16 MEMOBUS/Modbus registers can be read out at a time.

The following table shows message examples when reading status signals, error details, data link status, and frequency references from the slave 2 drive.

Command Message			Response Message (normal)			Response Message (fault)		
Slave Address		02H	Slave Address		02H	Slave Address		02H
Function Code		03H	Function Code		03H	Function Code		83H
Starting No.	Upper	00H	Data Quantity		08H	Error Code		03H
	Lower	20H	1st storage register	Upper	00H	CRC-16	Upper	F1H
Data Quantity	Upper	00H		Lower	65H		Lower	31H
	CRC-16	Lower	04H	Next storage register	Upper	00H		
Upper		45H	Lower		00H			
CRC-16	Lower	F0H	Next storage register	Upper	00H			
				Lower	00H			
			Next storage register	Upper	01H			
				Lower	F4H			
			CRC-16	Upper	AFH			
				Lower	82H			

### ◆ Loopback Test

Function code 08H performs a loopback test that returns a response message with exactly the same content as the command message. The response message can be used to check communications between the master and slave. User-defined test code and data values can also be set.

The following table shows a message example when performing a loopback test with the slave 1 drive.

Command Message			Response Message		
Slave Address		01H	Slave Address		01H
Function Code		08H	Function Code		08H
Test Code	Upper	00H	Test Code	Upper	00H
	Lower	00H		Lower	00H
Data	Upper	A5H	Data	Upper	A5H
	Lower	37H		Lower	37H
CRC-16	Upper	DAH	CRC-16	Upper	DAH
	Lower	8DH		Lower	8DH

### ◆ Writing to Multiple Registers

Function code 10H allows the user to write multiple drive MEMOBUS/Modbus registers with one message. This process works similar to reading registers, in that the address of the first register to be written and the data quantity are set in the command message. The data to be written must be consecutive so that the register addresses are in order, starting from the specified address in the command message. The data order must be high byte then lower byte.

The following table shows an example of a message where a forward operation has been set with a frequency reference of 60.00 Hz for the slave 1 drive.

If parameter values are changed using the Write command, an Enter command may be necessary to activate or save the data depending on the setting of H5-11. *Refer to H5-11: Communications Enter Function Selection on page 457* and *Refer to Enter Command on page 483* for detailed descriptions.

Command Message			Response Message (normal)			Response Message (fault)		
Slave Address		01H	Slave Address		01H	Slave Address		01H
Function Code		10H	Function Code		10H	Function Code		90H
Starting No.	Upper	00H	Starting No.	Upper	00H	Error Code		02H
	Lower	01H		Lower	01H	CRC-16	Upper	CDH
Data Quantity	Upper	00H	Data Quantity	Upper	00H		Lower	C1H
	Lower	02H		Lower	02H			
Number of Bytes		04H	CRC-16	Upper	10H			
Starting Data	Upper	00H		Lower	08H			
	Next Data	Upper	17H					
CRC-16		Upper	63H					
	Lower	39H						

**Note:** Double the number of the data quantity for the number of bytes in the command message.



## C.9 MEMOBUS/Modbus Data Table

The tables below list all MEMOBUS/Modbus data.

The MEMOBUS register hex addresses for parameters are listed beginning on page [351](#).

### ◆ Command Data

It is possible to both read and write command data.

**Note:** Bits that are not used should be set to 0. Refrain from writing to reserved registers.

Register No.	Contents	
0000H	Reserved	
0001H	Operation Commands and Multi-function Inputs	
	bit 0	H5-12 = 0: Forward Run Command (0 = Stop, 1 = Forward Run) H5-12 = 1: Run Command (0 = Stop, 1 = Run)
	bit 1	H5-12 = 0: Reverse Run Command (0 = Stop, 1 = Reverse Run) H5-12 = 1: Forward/Reverse (0 = Forward, 1 = Reverse)
	bit 2	External Fault (EF0)
	bit 3	Fault Reset
	bit 4	Multi-Function Input 1 Function is ComRef when H1-01 = 40 (Forward/Stop).
	bit 5	Multi-Function Input 2 Function is ComCtrl when H1-02 = 41 (Reverse/Stop).
	bit 6	Multi-Function Input 3
	bit 7	Multi-Function Input 4
	bit 8	Multi-Function Input 5
	bit 9	Multi-Function Input 6
	bit A	Multi-Function Input 7
	bit B	Multi-Function Input 8
	bit C to F	Reserved
0002H	Frequency Reference	Units are determined by parameter o1-03.
0003H	Output voltage gain/ Unit: 0.1% Range: 20 (2.0%) to 2000 (200.0%), Default when power on: 1000 (100.0%)	
0004H to 0005H	Reserved	
0006H	PID Target, 0.01% units, signed	
0007H	Analog Output Terminal FM Setting (10 V / 4000 H)	
0008H	Analog Output Terminal AM Setting (10 V / 4000 H)	
0009H	Settings for Multi-Function Digital Outputs	
	bit 0	Multi-Function Contact Output (Terminal M1-M2)
	bit 1	Multi-Function Contact Output (Terminal M3-M4)
	bit 2	Multi-Function Contact Output (Terminal MD-MF)
	bit 3 to 5	Reserved
	bit 6	Enables the function in bit 7
	bit 7	Fault Contact Output (terminal MA/MB-MC)
bit 8 to F	Reserved	
000AH to 000CH	Reserved	
000DH	PI2 Setpoint	
000EH	Reserved	

## C.9 MEMOBUS/Modbus Data Table

Register No.	Contents	
000FH	Control Selection Setting	
	bit 0	Reserved
	bit 1	PID Setpoint Input
	bit 2, 3	Reserved
	bit 4	PI2 Target Input
	bit 5 to B	Reserved
	bit C	Enable Terminal S5 Input for Broadcast Data
	bit D	Enable Terminal S6 Input for Broadcast Data
	bit E	Enable Terminal S7 Input for Broadcast Data
bit F	Enable Terminal S8 Input for Broadcast Data	
0010H to 001AH	Reserved	
001BH	Analog Monitor Option AO-A3 Analog Output 1 (10 V/4000 H)	
001CH	Analog Monitor Option AO-A3 Analog Output 2 (10 V/4000 H)	
001DH to 001FH	Reserved	
3004H	Set Time – Hours/Minutes (HHmm)	
3005H	Set Date – Year/Day of Week (YYdd)	
3006H	Set Date – Month/Day (MMDD)	
3007H	RTC Set Command/Statud 0 = Complete 1 = Set RTC data using registers 3004H to 3006H 8 = failed	
302FH	RTC Enter 0 = Overwrite RTC data using registers 3004H to 3006H. Only effective when 3030H bit 1 (RTC Enter Enable) is set.	
3030H	bit 1	RTC Enter Enable
	bit 2	RTC TIE Fault Enable

## ◆ Monitor Data

Monitor data can be read only.

Register No.	Contents	
0020H	Drive Status 1	
	bit 0	During Run
	bit 1	During Reverse
	bit 2	Drive Ready
	bit 3	Fault
	bit 4	Data Setting Error
	bit 5	Multi-Function Contact Output (terminal M1-M2)
	bit 6	Multi-Function Contact Output 2 (terminal M3-M4)
	bit 7	Multi-Function Contact Output 3 (terminal MD-ME-MF)
	bit 8 to bit D	Reserved
	bit E	ComRef status
	bit F	ComCtrl status
0021H	Fault Contents 1	
	bit 0	Overcurrent (oC), Ground fault (GF)
	bit 1	Overvoltage (ov)
	bit 2	Drive Overload (oL2)
	bit 3	Overheat 1 (oH1), Drive Overheat Warning (oH2)
	bit 4	Dynamic Braking Transistor Fault (rr), Braking Resistor Overheat (rH)
	bit 5	Reserved
	bit 6	PID Feedback Loss (FbL / FbH)
	bit 7	EF to EF8: External Fault
	bit 8	CPF□□: Hardware Fault (includes oFx)
	bit 9	Motor Overload (oL1), Overtorque Detection 1/2 (oL3/oL4), Undertorque Detection 1/2 (UL3/UL4)
	bit A	Reserved
	bit B	Main Circuit Undervoltage (Uv)
	bit C	Undervoltage (Uv1), Control Power Supply Undervoltage (Uv2), Soft Charge Circuit Fault (Uv3)
	bit D	Output Phase Loss (LF), Input Phase Loss (PF)
bit E	MEMOBUS/Modbus Communication Error (CE), Option Communication Error (bUS)	
bit F	Operator Connection Fault (oPr)	
0022H	Data Link Status	
	bit 0	Writing data or switching motors
	bit 1	Reserved
	bit 2	
	bit 3	Upper or lower limit error
	bit 4	Data conformity error
	bit 5	Writing to EEPROM
bit 6 to bit F	Reserved	
0023H	Frequency Reference </>	
0024H	Output Frequency </>	
0025H	Output Voltage Reference, 0.1 V units (units are determined by parameter H5-10)	
0026H	Output Current, 0.1 A units	
0027H	Output Power	
0028H	Reserved	

## C.9 MEMOBUS/Modbus Data Table

Register No.	Contents	
0029H	Fault Contents 2	
	bit 0	IGBT Short Circuit (SC)
	bit 1	Ground Fault (GF)
	bit 2	Input Phase Loss (PF)
	bit 3	Output Phase Loss (LF)
	bit 4	Braking Resistor Overheat (rH)
	bit 5	Reserved
	bit 6	Motor Overheat 2 (PTC input) (oH4)
	bit 7 to bit F	Reserved
002AH	Alarm Contents 1	
	bit 0, 1	Reserved
	bit 2	Run Command Input Error (EF)
	bit 3	Drive Baseblock (bb)
	bit 4	Overtorque Detection 1 (oL3)
	bit 5	Heatsink Overheat (oH)
	bit 6	Overvoltage (ov)
	bit 7	Undervoltage (Uv)
	bit 8	Cooling Fan Error (FAn)
	bit 9	MEMOBUS/Modbus Communication Error (CE)
	bit A	Option Communication Error (bUS)
	bit B	Undertorque Detection 1/2 (UL3/UL4)
	bit C	Motor Overheat (oH3)
	bit D	PID Feedback Loss (FbL, FbH)
	bit E	Reserved
bit F	Serial Communication Transmission Error (CALL)	
002BH	Input Terminal Status	
	bit 0	Terminal S1 Closed
	bit 1	Terminal S2 Closed
	bit 2	Terminal S3 Closed
	bit 3	Terminal S4 Closed
	bit 4	Terminal S5 Closed
	bit 5	Terminal S6 Closed
	bit 6	Terminal S7 Closed
	bit 7	Terminal S8 Closed
	bit 8 to bit F	Reserved

Register No.	Contents	
002CH	Drive Status 2	
	bit 0	During Run
	bit 1	Zero Speed
	bit 2	Speed Agree
	bit 3	User Speed Agree
	bit 4	Frequency Detection 1
	bit 5	Frequency Detection 2
	bit 6	Drive Ready
	bit 7	During Undervoltage
	bit 8	During Baseblock
	bit 9	Frequency Reference from Operator Keypad
	bit A	Run Command from Operator Keypad
	bit B	Over/Undertorque 1, 2
	bit C	Frequency Reference Loss
	bit D	During Fault Restart
	bit E	Fault
bit F	Communication Timeout	
002DH	Output Terminal Status	
	bit 0	Multi-Function Contact Output 1 (terminal MD-ME-MF)
	bit 1	Multi-Function Contact Output 2 (terminal M1-M2)
	bit 2	Multi-Function Contact Output 3 (terminal M3-M4)
	bit 3 to 6	Reserved
	bit 7	Fault Contact Output (terminal MA/MB-MC)
	bit 8 to F	Reserved
002EH	Reserved	
002FH	Frequency Reference Bias (from Up/Down 2 Function), 0.1% units	
0030H	Reserved	
0031H	DC Bus Voltage, 1 Vdc units	
0032H to 0033H	Reserved	
0034H	Product Code 1 [ASCII], Product Type	
0035H	Product Code 2 [ASCII], Region Code	
0036H, 0037H	Reserved	
0038H	PID Feedback, 0.1% units, unsigned, 100% / max. output frequency	
0039H	PID Input, 0.1% units, signed, 100% / max. output frequency	
003AH	PID Output, 0.1% units, signed, 100% / max. output frequency	
003BH, 003CH	Reserved	
003DH	Communications Error Contents <>	
	bit 0	CRC Error
	bit 1	Data Length Error
	bit 2	Reserved
	bit 3	Parity Error
	bit 4	Overrun Error
	bit 5	Framing Error
	bit 6	Timeout
	bit 7 to bit F	Reserved
003EH	Output Frequency	r/min <4>
003FH		0.01% units
0040H to 004AH	Used for various monitors U1-□□. Refer to U: Monitors on page 437 for parameter details.	

## C.9 MEMOBUS/Modbus Data Table

Register No.	Contents	
004BH	Drive status (U1-12)	
	bit 0	During Run
	bit 1	During Zero Speed
	bit 2	During Reverse Run
	bit 3	During Fault Reset Signal Input
	bit 4	During Speed Agree
	bit 5	Drive Ready
	bit 6	Alarm
	bit 7	Fault
	bit 8	During Operation Error (oPE□□)
	bit 9	During Momentary Power Loss
	bit A to B	Reserved
	bit C	Auto Mode
	bit D	Hand Mode
	bit E	ComRef status, NetRef status
bit F	ComCtrl status, NetCtrl status	
004CH to 007EH	Used for various monitors U1-□□, U4-□□, U5-□□ and U6-□□. <i>Refer to U2: Fault Trace on page 440 and Refer to U3: Fault History on page 442</i> for parameter details.	
007FH	Alarm Code, <i>Refer to Alarm Register Contents on page 481</i> for alarm codes.	
0080H to 0097H	Used for monitors U2-□□, U3-□□. <i>Refer to U: Monitors on page 437</i> for parameter details and <i>Refer to Fault Trace Contents on page 479</i> for register value descriptions.	
0098H	High Word of Accumulated Operation Time Monitor, 10 h units (U4-01)	
0099H	Low Word of Accumulated Operation Time Monitor, 1 h units (U4-01)	
009AH	High Word of Cooling Fan Operation Time Monitor (U4-03)	
009BH	Low Word of Cooling Fan Operation Time Monitor (U4-03)	
009CH to 00AAH	Reserved	
00ABH	Drive Rated Current <2>	
00ACH to 00AFH	Reserved	
00B0H	Option Code Connected to CN5-A	Register contains ASCII code of the option card. AO-A3 = 0004H Communication Option: Register contains ASCII code of first and third digit of the option card type number. Example: Register value is 5343H for "SC" if an SI-C3 option card is installed.
00B1H	Reserved	
00B2H	Option Code Connected to CN5-B	
00B3H	Option Code Connected to CN5-C	
00B4H	Reserved	
00B5H	Frequency Reference After	r/min units <4>
00B6H	Soft-starter (U1-16)	0.01% units
00B7H	Frequency Reference	r/min <4>
00B8H		0.01% units
00B9H to 00BEH	Reserved	
00BFH	Lists the last two digits of operation error code oPE□□.	

Register No.	Contents	
00C0H	Fault Contents 3	
	bit 1	Undervoltage (Uv1)
	bit 2	Control Power Supply Undervoltage (Uv2)
	bit 3	Soft Charge Circuit Fault (Uv3)
	bit 4	IGBT Short Circuit (SC)
	bit 5	Ground Fault (GF)
	bit 6	Overcurrent (oC)
	bit 7	Overvoltage (ov)
	bit 8	Heatsink Overheat (oH)
	bit 9	Heatsink Overheat (oH1)
	bit A	Motor Overload (oL1)
	bit B	Drive Overload (oL2)
	bit C	Overtorque Detection 1 (oL3)
	bit D	Overtorque Detection 2 (oL4)
	bit E	Dynamic Braking Transistor Fault (rr)
bit F	Braking Resistor Overheat (rH)	
00C1H	Fault Contents 4	
	bit 0	External Fault at input terminal S3 (EF3)
	bit 1	External Fault at input terminal S4 (EF4)
	bit 2	External Fault at input terminal S5 (EF5)
	bit 3	External Fault at input terminal S6 (EF6)
	bit 4	External Fault at input terminal S7 (EF7)
	bit 5	External Fault at input terminal S8 (EF8)
	bit 6	Cooling Fan Error (FAn)
	bit 7 to 9	Reserved
	bit A	Input Phase Loss (PF)
	bit B	Output Phase Loss (LF)
	bit C	Motor Overheat (PTC input) (oH3)
	bit D	Digital Operator Connection Fault (oPr)
	bit E	EEPROM Write Error (Err)
bit F	Motor Overheat Fault (PTC input) (oH4)	
00C2H	Fault Contents 5	
	bit 0	MEMOBUS/Modbus Communication Error (CE)
	bit 1	Option Communication Error (bUS)
	bit 2 to 3	Reserved
	bit 4	Control Fault (CF)
	bit 5	Reserved
	bit 6	Option External Fault (EF0)
	bit 7	PID Feedback Loss (FbL)
	bit 8	Undertorque Detection 1 (UL3)
	bit 9	Undertorque Detection 2 (UL4)
	bit A	High Slip Braking Overload (oL7)
	bit B to E	Reserved
bit F	Hardware Fault (includes oFx)	

## C.9 MEMOBUS/Modbus Data Table

Register No.	Contents	
00C3H	Fault Contents 6	
	bit 0 to 4	Reserved
	bit 5	Current Imbalance (LF2)
	bit 6	Pullout Detection (STo)
	bit 7	Reserved
	bit 8	SI-T3 Watchdog Error (E5)
	bit 9	Reserved
	bit A	Too many speed search restarts (SEr)
	bit B to F	Reserved
00C4H	Fault Contents 7	
	bit 0	PID Feedback Loss (FbH)
	bit 1	External Fault 1, input terminal S1 (EF1)
	bit 2	External Fault 2, input terminal S2 (EF2)
	bit 3, 4	Reserved
	bit 5	Current Offset Fault (CoF)
	bit 6 to B	Reserved
	bit C	Output Voltage Detection Fault (voF)
	bit D	Braking Resistor Fault (rF)
	bit E	Braking Transistor Overload Fault (boL)
bit F	Motor Overheat (NTC Input) (oH5)	
00C5H	Fault Contents 8	
	bit 0	Reserved
	bit 1	Node Setup Fault (nSE)
	bit 2	Thermistor Disconnect (THo)
	bit 3 to 8	Reserved
	bit 9	Underload Detection 6 (UL6)
	bit A, B	Reserved
	bit C	HOA Time Not Set (TIM)
	bit D	HOA Battery Low (bAT)
	bit E	HOA Time Data Error (TdE)
bit F	HOA Time Interval Error (TIE)	
00C6H	Fault Contents 9	
	bit 0	Loss of Prime (LOP)
	bit 1	Low Flow (LOWFL)
	bit 2	Accum Level (ACCUM)
	bit 3	Low Feedback (LFB)
	bit 4	High Feedback (HFB)
	bit 5	Setpoint Not Met (NMS)
	bit 6	Pump Over Cycle (POC)
	bit 7	Reserved
	bit 8	Net Master Lost (MSL)
	bit 9	High Flow (HIFLO)
	bit A	Anti-Jam Fault (AJF)
	bit B	Low Water Level (LOWWL)
	bit C	Wire Break (FDBKL)
	bit D	Low Suction (LOSUC)
bit E	Geothermal Input (TLGI)	
bit F	Low Water Level (LWL)	



Register No.	Contents	
00C7H	Fault Contents 10	
	bit 0	High Water Level (HWL)
	bit 1	High Suction (HISUC)
	bit 2	Water Level Loss (WLL)
	bit 3	SuctionPres Loss (SPL)
	bit 4	Volute-TStat Flt (VLTS)
	bit 5 to F	Reserved
00C8H	Alarm Contents 2	
	bit 0	Undervoltage (Uv)
	bit 1	Overvoltage (ov)
	bit 2	Heatsink Overheat (oH)
	bit 3	Drive Overheat (oH2)
	bit 4	Overtorque 1 (oL3)
	bit 5	Overtorque 2 (oL4)
	bit 6	Run Commands Input Error (EF)
	bit 7	Drive Baseblock (bb)
	bit 8	External Fault 3, input terminal S3 (EF3)
	bit 9	External Fault 4, input terminal S4 (EF4)
	bit A	External Fault 5, input terminal S5 (EF5)
	bit B	External Fault 6, input terminal S6 (EF6)
	bit C	External Fault 7, input terminal S7 (EF7)
	bit D	External Fault 8, input terminal S8 (EF8)
bit E	Cooling Fan Error (FAn)	
bit F	Reserved	
00C9H	Alarm Contents 3	
	bit 0, 1	Reserved
	bit 2	Digital Operator Connection Fault (oPr)
	bit 3	MEMOBUS/Modbus Communication Error (CE)
	bit 4	Option Communication Error (bUS)
	bit 5	Serial Communication Transmission Error (CALL)
	bit 6	Motor Overload (oL1)
	bit 7	Drive Overload (oL2)
	bit 8	Reserved
	bit 9	Option Card External fault (EF0)
	bit A, B	Reserved
	bit C	Serial Communication Transmission Error (CALL)
	bit D	Undertorque Detection 1 (UL3)
	bit E	Undertorque Detection 2 (UL4)
bit F	MEMOBUS/Modbus Test Mode Fault (SE)	
00CAH	Alarm Contents 4	
	bit 0	Reserved
	bit 1	Motor Overheat 1 (PTC Input) (oH3)
	bit 2 to 5	Reserved
	bit 6	PID Feedback Loss (FbL)
	bit 7	PID Feedback Loss (FbH)
	bit 9	Drive Disabled (dnE)
bit A to F	Reserved	



## C.9 MEMOBUS/Modbus Data Table

Register No.	Contents	
00CBH	Alarm Contents 5	
	bit 0	SI-T3 Watchdog Error (E5)
	bit 1	SI-T3 Station Address Setting Error (AEr)
	bit 2	SI-T3 Comm. Cycle Setting Error (CyC)
	bit 3	High Current Alarm (HCA)
	bit 4	Cooling Fan Maintenance Time (LT-1)
	bit 5	Soft Charge Bypass Relay Maintenance Time (LT-2)
	bit 6	Reserved
	bit 7	SI-S EEPROM Error (EEP)
	bit 8	External Fault 1 (input terminal S1) (EF1)
	bit 9	External Fault 2 (input terminal S2) (EF2)
bit A to F	Reserved	
00CCH	Alarm Contents 6	
	bit 0	Output Voltage Detection Fault (VoF)
	bit 1	IGBT Maintenance Time (90%) (TrPC)
	bit 2	Capacitor Maintenance Time (LT-3)
	bit 3	IGBT Maintenance Time (50%) (LT-4)
	bit 4	Braking Transistor Overload Fault (boL)
	bit 5	Low Flow (LOWFL)
	bit 6	Accum Level (ACCUM)
	bit 7	Motor Overheat (NTC Input) (oH5)
	bit 8	Reserved
	bit 9	High Flow (HIFLO)
	bit A	Low Suction (LOSUC)
	bit B	Loss Of Prime (LOP)
	bit C	Thermistor Disconnect (THo)
	bit D	Underload Detection 6 (UL6)
	bit E	Waiting for Run (wRun)
bit F	AnalogFB Lost: Switched to Net	
00CDH	Alarm Contents 7	
	bit 0	NETSCAN Wait for Master
	bit 1	Pump Cycling Pump Over Cycle
	bit 2	Low Feedback Low FB Sensed
	bit 3	High Feedback High FB Sensed
	bit 4	Reserved
	bit 5	Freq. Ref < Pump Min P1-06
	bit 6	Freq. Ref < Thrust (P4-12)
	bit 7	Low City Pressure
	bit 8	Anti-Jam Active
	bit 9	Low Water Level (LOWWL)
	bit A	AnalogWL/SP Lost: Switched to Net
	bit B	Feedback Loss Wire Break
	bit C	Net FlowMeter Lost
	bit D	R-DNE-Sx : Remote Drv Dis
	bit E	Low Suction Pressure
bit F	Low Water in Tank	

Register No.	Contents	
00CEH	Alarm Contents 8	
	bit 0	Temp Lost Geothermal Input (TLGI)
	bit 1	Geo Params Chk Q2-05~Q2-08
	bit 2	Time Not Set (TIM)
	bit 3	Battery Low (bAT)
	bit 4	Time Deviation Error (TdE)
	bit 5	Setpoint Not Met (NMS)
	bit 6	Emergency Override FWD (EoF)
	bit 7	Emergency Override REV (Eor)
	bit 8	Feedback Loss Go To B5-13
	bit 9	Network Low WL/SP Drive Disabled
	bit A	Analog Geo Temp Lost Switched to Net
	bit B	High Suction (HISUC)
	bit C	Water Lvl Loss (WLL)
	bit D	SuctionPres Loss (SPL)
bit E, F	Reserved	
00CFH	Reserved	
00D0H	CPF Contents 1	
	bit 0, 1	Reserved
	bit 2	A/D Conversion Error (CPF02)
	bit 3	PWM Data Fault (CPF03)
	bit 4, 5	Reserved
	bit 6	EEPROM Memory Data Error (CPF06)
	bit 7	Terminal Board Connection Error (CPF07)
	bit 8	EEPROM Serial Communications Fault (CPF08)
	bit 9, A	Reserved
	bit B	RAM Fault (CPF11)
	bit C	FLASH Memory Fault (CPF12)
	bit D	Watchdog Circuit Exception (CPF13)
	bit E	Control Circuit Fault (CPF14)
bit F	Reserved	
00D1H	CPF Contents 2	
	bit 0	Clock Fault (CPF16)
	bit 1	Timing Fault (CPF17)
	bit 2	Control Circuit Fault (CPF18)
	bit 3	Control Circuit Fault (CPF19)
	bit 4	Hardware fault at power up (CPF20)
	bit 5	Hardware fault at communication start up (CPF21)
	bit 6	A/D Conversion Fault (CPF22)
	bit 7	PWM Feedback Fault (CPF23)
	bit 8	Drive Unit Signal Fault (CPF24)
	bit 9	Terminal board is not properly connected. (CPF25)
	bit A	ASIC BB Circuit Error (CPF26)
	bit B	ASIC PWM Setting Register Error (CPF27)
	bit C	ASIC PWM Pattern Error (CPF28)
	bit D	ASIC On-delay Error (CPF29)
bit E	ASIC BBON Error (CPF30)	
bit F	ASIC Code Error (CPF31)	

## C.9 MEMOBUS/Modbus Data Table

Register No.	Contents	
00D2H	bit 0	ASIC Start-up Error (CPF32)
	bit 1	Watch-dog Error (CPF33)
	bit 2	ASIC Power/Clock Error (CPF34)
	bit 3	External A/D Converter Error (CPF35)
	bit 4 to 7	Reserved
	bit 8	Control Circuit Error (CPF40)
	bit 9	Control Circuit Error (CPF41)
	bit A	Control Circuit Error (CPF42)
	bit B	Control Circuit Error (CPF43)
	bit C	Control Circuit Error (CPF44)
	bit D	Control Circuit Error (CPF45)
	bit E, F	Reserved
00D3H to 00D7H	Reserved	
00D8H	oFA0x Contents (CN5-A)	
	bit 0	Option Compatibility Error (oFA00)
	bit 1	Option not properly connected (oFA01)
	bit 2	Same type of option card already connected (oFA02)
	bit 3, 4	Reserved
	bit 5	A/D Conversion Error (oFA05)
	bit 6	Option Response Error (oFA06)
	bit 7 to F	Reserved
00D9H	oFA1x Contents (CN5-A)	
	bit 0	Option RAM Fault (oFA10)
	bit 1	Option Operation Mode Fault (SLMOD) (oFA11)
	bit 2	Drive Receive CRC Error (oFA12)
	bit 3	Drive Receive Frame Error (oFA13)
	bit 4	Drive Receive Abort Error (oFA14)
	bit 5	Option Receive CRC Error (oFA15)
	bit 6	Option Receive Frame Error (oFA16)
	bit 7	Option Receive Abort Error (oFA17)
bit 8 to F	Reserved	
00DAH to 00DBH	Reserved	
00DBH	oFA3x Contents (CN5-A)	
	bit 0	Comm. ID Error (oFA30)
	bit 1	Model Code Error (oFA31)
	bit 2	Sumcheck Error (oFA32)
	bit 3	Comm. option timeout waiting for response (oFA33)
	bit 4	MEMOBUS Timeout (oFA34)
	bit 5	Drive timeout waiting for response (oFA35)
	bit 6	CI Check Error (oFA36)
	bit 7	Drive timeout waiting for response (oFA37)
	bit 8	Control Command Selection Error (oFA38)
	bit 9	Drive timeout waiting for response (oFA39)
	bit A	Control Response Selection 1 Error (oFA40)
	bit B	Drive timeout waiting for response (oFA41)
	bit C	Control Response Selection 2 Error (oFA42)
	bit D	Control Response Selection Error (oFA43)
bit E, F	Reserved	

Register No.	Contents	
00DCH	oFb0x Contents (CN5-B)	
	bit 0	Option compatibility error (oFb00)
	bit 1	Option not properly connected (oFb01)
	bit 2	Same type of option card already connected (oFb02)
	bit 3, 4	Reserved
	bit 5	A/D Conversion Fault (oFb05)
	bit 6	Option Response Error (oFb06)
	bit 7 to F	Reserved
00DDH	oFb1x Contents (CN5-B)	
	bit 0	Option RAM Fault (oFb10)
	bit 1	Option Operation Mode Fault (SLMOD) (oFb11)
	bit 2	Drive Receive CRC Error (oFb12)
	bit 3	Drive Receive Frame Error (oFb13)
	bit 4	Drive Receive Abort Error (oFb14)
	bit 5	Option Receive CRC Error (oFb15)
	bit 6	Option Receive Frame Error (oFb16)
	bit 7	Option Receive Abort Error (oFb17)
bit 8 to F	Reserved	
00DEH to 00DFH	Reserved	
00E0H	oFb3x Contents (CN5-B)	
	bit 0	Comm. ID Error (oFb30)
	bit 1	Model Code Error (oFb31)
	bit 2	Sumcheck Error (oFb32)
	bit 3	Comm. option timeout waiting for response (oFb33)
	bit 4	MEMOBUS Timeout (oFb34)
	bit 5	Drive timeout waiting for response (oFb35)
	bit 6	CI Check Error (oFb36)
	bit 7	Drive timeout waiting for response (oFb37)
	bit 8	Control Command Selection Error (oFb38)
	bit 9	Drive timeout waiting for response (oFb39)
	bit A	Control Response Selection 1 Error (oFb40)
	bit B	Drive timeout waiting for response (oFb41)
	bit C	Control Response Selection 2 Error (oFb42)
	bit D	Control Response Selection Error (oFb43)
bit E, F	Reserved	
00E1H	oFC0x Contents (CN5-C)	
	bit 0	Option compatibility error (oFC00)
	bit 1	Option not properly connected (oFC01)
	bit 2	Same type of option card already connected (oFC02)
	bit 3, 4	Reserved
	bit 5	A/D Conversion Fault (oFC05)
	bit 6	Option Response Error (oFC06)
	bit 7 to F	Reserved

## C.9 MEMOBUS/Modbus Data Table

Register No.	Contents	
00E2H	oFC1x Contents (CN5-C)	
	bit 0	Option RAM Fault (oFC10)
	bit 1	Option Operation Mode Fault (SLMOD) (oFC11)
	bit 2	Drive Receive CRC Error (oFC12)
	bit 3	Drive Receive Frame Error (oFC13)
	bit 4	Drive Receive Abort Error (oFC14)
	bit 5	Option Receive CRC Error (oFC15)
	bit 6	Option Receive Frame Error (oFC16)
	bit 7	Option Receive Abort Error (oFC17)
	bit 8 to F	Reserved
00E3H, 00E4H	Reserved	
00E5H	oFC3x Contents (CN5-C)	
	bit 0	Comm. ID Error (oFC30)
	bit 1	Model Code Error (oFC31)
	bit 2	Sumcheck Error (oFC32)
	bit 3	Comm. option timeout waiting for response (oFC33)
	bit 4	MEMOBUS Timeout (oFC34)
	bit 5	Drive timeout waiting for response (oFC35)
	bit 6	CI Check Error (oFC36)
	bit 7	Drive timeout waiting for response (oFC37)
	bit 8	Control Command Selection Error (oFC38)
	bit 9	Drive timeout waiting for response (oFC39)
	bit A	Control Response Selection 1 Error (oFC40)
	bit B	Drive timeout waiting for response (oFC41)
	bit C	Control Response Selection 2 Error (oFC42)
	bit D	Control Response Selection Error (oFC43)
bit E, F	Reserved	
00E6H to 00FFH	Reserved	

- <1> Parameter o1-03, Digital Operator Display Selection, determines the units.
- <2> Display is in the following units:  
 2A0004 to 2A0040, 4A0002 to 4A0023, and 5A0007 to 5A0017: 0.01 A units.  
 2A0056 to 2A0415, 4A0031 to 4A0675, and 5A0022 to 5A0242: 0.1 A units.  
 4A0930 and 4A1200: 1 A units.
- <3> Communication error contents are saved until the fault is reset.
- <4> Set the number of motor poles to parameter E2-04.

### ◆ Broadcast Messages

Data can be written from the master to all slave devices at the same time.

The slave address in a broadcast command message must be set to 00H. All slaves will receive the message, but will not respond.

Register No.	Contents	
0001H	Digital Input Command	
	bit 0	Forward Run (0: Stop 1: Run)
	bit 1	Direction Command (0: Forward, 1: Reverse)
	bit 2, 3	Reserved
	bit 4	External Fault
	bit 5	Fault Reset
	bit 6 to B	Reserved
	bit C	Multi-Function Digital Input S5
	bit D	Multi-Function Digital Input S6
	bit E	Multi-Function Digital Input S7
bit F	Multi-Function Digital Input S8	
0002H	Frequency Reference	30000/100%

### ◆ Fault Trace Contents

The table below shows the fault codes that can be read out by MEMOBUS/Modbus commands from the U2-□□ monitor parameters.

Table C.5 Fault Trace / History Register Contents

Fault Code	Fault Name	Fault Code	Fault Name
0002H	Undervoltage (Uv1)	0021H	MEMOBUS/Modbus Communication Error (CE)
0003H	Control Power Supply Undervoltage (Uv2)	0022H	Option Communication Error (bUS)
0004H	Soft Charge Circuit Fault (Uv3)	0027H	Option External Fault (EF0)
0005H	IGBT Short Circuit (SC)	0028H	PID Feedback Loss (FbL)
0006H	Ground Fault (GF)	0029H	Undertorque Detection 1 (UL3)
0007H	Overcurrent (oC)	002AH	Undertorque Detection 2 (UL4)
0008H	Overvoltage (ov)	002BH	High Slip Braking Overload (oL7)
0009H	Heatsink Overheat (oH)	0030H	Hardware Fault (including oFx)
000AH	Heatsink Overheat (oH1)	0036H	Output Current Imbalance (LF2)
000BH	Motor Overload (oL1)	0037H	Pullout Detection (Sto)
000CH	Drive Overload (oL2)	003BH	Too Many Speed Search Restarts (SEr)
000DH	Overtorque Detection 1 (oL3)	0041H	PID Feedback Loss (FbH)
000EH	Overtorque Detection 2 (oL4)	0042H	Pump Fault 1, Input Terminal S1 (EF1)
000FH	Dynamic Braking Transistor (tr)	0043H	Pump Fault 2, Input Terminal S2 (EF2)
0010H	Braking Resistor Overheat (rH)	0046H	Current Offset Fault (CoF)
0011H	Pump Fault at Input Terminal S3 (EF3)	0047H	PLC Detection Error 1 (PE1)
0012H	Pump Fault at Input Terminal S4 (EF4)	0048H	PLC Detection Error 2 (PE2)
0013H	Pump Fault at Input Terminal S5 (EF5)	004DH	Output Voltage Detection Fault (voF)
0014H	Pump Fault at Input Terminal S6 (EF6)	004EH	Braking Resistor Transistor Fault (rF)
0015H	Pump Fault at Input Terminal S7 (EF7)	004FH	Braking Transistor Overload Fault (boL)
0016H	Pump Fault at Input Terminal S8 (EF8)	0050H	Motor Overheat (NTC Input) (oH5)
001BH	Input Phase Loss (PF)	0052H	Node Setup Fault (nSE)
001CH	Output Phase Loss (LF)	0053H	Thermistor Disconnect (THo)
001DH	Motor Overheat (PTC input) (oH3)	005AH	Underload Detection 6 (UL6)
001EH	Digital Operator Connection (oPr)	005DH	HOA Time Not Set (TIM)
001FH	EEPROM Write Error (Err)	005EH	HOA Battery Low (bAT)
0020H	Motor Overheat (PTC input) (oH4)	005FH	HOA Time Deviation Error (TdE)

## C.9 MEMOBUS/Modbus Data Table

Fault Code	Fault Name	Fault Code	Fault Name
0060H	HOA Time Interval Error (TIE)	00A9H	Control Circuit Error (CPF40)
0061H	Loss of Prime (LOP)	00AAH	Control Circuit Error (CPF41)
0062H	Low Flow (LOWFL)	00ABH	Control Circuit Error (CPF42)
0063H	Accum Level (ACCUM)	00ACH	Control Circuit Error (CPF43)
0064H	Low Feedback (LFB)	00ADH	Control Circuit Error (CPF44)
0065H	High Feedback (HFB)	00AEH	Control Circuit Error (CPF45)
0066H	Setpoint Not Met (NMS)	0101H	Option Compatibility Error (oFA00)
0067H	Pump Over Cycle (POC)	0102H	Option Not Properly Connected (oFA01)
0069H	Net Master Lost (MSL)	0103H	Same Type of Option Card Already Connected (oFA02)
006AH	High Flow (HIFLO)	0106H	A/D Conversion Error (oFA05)
006BH	Anti-Jam Fault (AJF)	0107H	Option Response Error (oFA06)
006CH	Low Water Level (LOWWL)	0111H	Option RAM Fault (oFA10)
006DH	Wire Break (FDBKL)	0112H	Option Operation Mode Fault (SLMOD) (oFA11)
006EH	Low Suction (LOSUC)	0113H	Drive Receive CRC Error (oFA12)
006FH	Geothermal Input (TLGI)	0114H	Drive Receive Frame Error (oFA13)
0070H	Low Water Level (LWL)	0115H	Drive Receive Abort Error (oFA14)
0071H	High Water Level (HWL)	0116H	Option Receive CRC Error (oFA15)
0072H	High Suction (HISUC)	0117H	Option Receive Frame Error (oFA16)
0073H	Water Level Loss (WLL)	0118H	Option Receive Abort Error (oFA17)
0074H	SuctionPres Loss (SPL)	0131H	Comm. ID Error (oFA30)
0075H	Volute-Thermostat Fault (VLTS)	0132H	Model Code Error (oFA31)
0083H	A/D Conversion Error (CPF02)	0133H	Sumcheck Error (oFA32)
0084H	PWM Data Fault (CPF03)	0134H	Comm. Option Timeout Waiting for Response (oFA33)
0087H	EEPROM Memory Data Error (CPF06)	0135H	MEMOBUS Timeout (oFA34)
0088H	Terminal Board Connection Error (CPF07)	0136H	Drive Timeout Waiting for Response (oFA35)
0089H	EEPROM Serial Communication Fault (CPF08)	0137H	CI Check Error (oFA36)
008CH	RAM Fault (CPF11)	0138H	Drive Timeout Waiting for Response (oFA37)
008DH	Flash Memory Circuit Exception (CPF12)	0139H	Control Command Selection Error (oFA38)
008EH	Watchdog Circuit Exception (CPF13)	013AH	Drive Timeout Waiting for Response (oFA39)
008FH	Control Circuit Fault (CPF14)	013BH	Control Response Selection 1 Error (oFA40)
0091H	Clock Fault (CPF16)	013CH	Drive Timeout Waiting for Response (oFA41)
0092H	Timing Fault (CPF17)	013DH	Control Response Selection 2 Error (oFA42)
0093H	Control Circuit Fault (CPF18)	013EH	Control Response Selection Error (oFA43)
0094H	Control Circuit Fault (CPF19)	0200H	Option Compatibility Error (oFb00)
0095H	Hardware Fault at Power Up (CPF20)	0202H	Option Connection Error (oFb01)
0096H	Hardware Fault at Communication Start Up (CPF21)	0203H	Same Type of Option Card Already Connected (oFb02)
0097H	A/D Conversion Fault (CPF22)	0206H	A/D Conversion Error (oFb05)
0098H	PWM Feedback Fault (CPF23)	0207H	Option Response Error (oFb06)
0099H	Drive Unit Signal Fault (CPF24)	0211H	Option RAM Fault (oFb10)
009AH	Terminal Board is Not Properly Connected. (CPF25)	0212H	Option Operation Mode Fault (SLMOD) (oFb11)
009BH	ASIC BB Circuit Error (CPF26)	0213H	Drive Receive CRC Error (oFb12)
009CH	ASIC PWM Setting Register Error (CPF27)	0214H	Drive Receive Frame Error (oFb13)
009DH	ASIC PWM Pattern Error (CPF28)	0215H	Drive Receive Abort Error (oFb14)
009EH	ASIC On-delay Error (CPF29)	0216H	Option Receive CRC Error (oFb15)
009FH	ASIC BBON Error (CPF30)	0217H	Option Receive Frame Error (oFb16)
00A0H	ASIC Code Error (CPF31)	0218H	Option Receive Abort Error (oFb17)
00A1H	ASIC Start-up Error (CPF32)	0231H	Comm. ID Error (oFb30)
00A2H	Watch-dog Error (CPF33)	0232H	Model Code Error (oFb31)
00A3H	ASIC Power/Clock Error (CPF34)		
00A4H	External A/D Converter Error (CPF35)		



Fault Code	Fault Name
0233H	Sumcheck Error (oFb32)
0234H	Comm. option Timeout Waiting for Response (oFb33)
0235H	MEMOBUS Timeout (oFb34)
0236H	Drive Timeout Waiting for Response (oFb35)
0237H	CI Check Error (oFb36)
0238H	Drive Timeout Waiting for Response (oFb37)
0239H	Control Command Selection Error (oFb38)
023AH	Drive Timeout Waiting for Response (oFb39)
023BH	Control Response Selection 1 Error (oFb40)
023CH	Drive Timeout Waiting for Response (oFb41)
023DH	Control Response Selection 2 Error (oFb42)
023EH	Control Response Selection Error (oFb43)
0301H	Option Compatibility Error (oFC00)
0302H	Option Not Properly Connected (oFC01)
0303H	Same Type of Option Card Already Connected (oFC02)
0306H	A/D Conversion Error (oFC05)
0307H	Option Response Error (oFC06)
0311H	Option RAM Fault (oFC10)
0312H	Option Operation Mode Fault (SLMOD) (oFC11)
0313H	Drive Receive CRC Error (oFC12)

Fault Code	Fault Name
0314H	Drive Receive Frame Error (oFC13)
0315H	Drive Receive Abort Error (oFC14)
0316H	Option Receive CRC Error (oFC15)
0317H	Option Receive Frame Error (oFC16)
0318H	Option Receive Abort Error (oFC17)
0331H	Comm. ID Error (oFC30)
0332H	Model Code Error (oFC31)
0333H	Sumcheck Error (oFC32)
0334H	Comm. Option Timeout Waiting for Response (oFC33)
0335H	MEMOBUS Timeout (oFC34)
0336H	Drive Timeout Waiting for Response (oFC35)
0337H	CI Check Error (oFC36)
0338H	Drive Timeout Waiting for Response (oFC37)
0339H	Control Command Selection Error (oFC38)
033AH	Drive Timeout Waiting for Response (oFC39)
033BH	Control Response Selection 1 Error (oFC40)
033CH	Drive Timeout Waiting for Response (oFC41)
033DH	Control Response Selection 2 Error (oFC42)
033EH	Control Response Selection Error (oFC43)

### ◆ Alarm Register Contents

The table below shows the alarm codes that can be read out from MEMOBUS/Modbus register 007FH.

Table C.6 Alarm Register 007FH Contents

Fault Code	Fault Name	Fault Code	Fault Name
0001H	Undervoltage (Uv)	001FH	Undertorque Detection 2 (UL4)
0002H	Overvoltage (ov)	0020H	MEMOBUS/Modbus Test Mode Fault (SE)
0003H	Heatsink Overheat (oH)	0022H	Motor Overheat (oH3)
0004H	Drive Overheat (oH2)	0027H	PID Feedback Loss (FbL)
0005H	Overtorque 1 (oL3)	0028H	PID Feedback Loss (FbH)
0006H	Overtorque 2 (oL4)	002AH	Drive Disabled (dnE)
0007H	Run commands input error (EF)	0031H	SI-T3 Watchdog Error (E5)
0008H	Drive Baseblock (bb)	0032H	SI-T3 Station Address Setting Error (AEr)
0009H	Pump Fault 3, input terminal S3 (EF3)	0033H	SI-T3 Comm. Cycle Setting Error (CyC)
000AH	Pump Fault 4, input terminal S4 (EF4)	0034H	High Current Alarm (HCA)
000BH	Pump Fault 5, input terminal S5 (EF5)	0035H	Cooling Fan Maintenance Time (LT-1)
000CH	Pump Fault 6, input terminal S6 (EF6)	0036H	Capacitor Maintenance Time (LT-2)
000DH	Pump Fault 7, input terminal S7 (EF7)	0038H	SI-S EEPROM Error (EEP)
000EH	Pump Fault 8, input terminal S8 (EF8)	0039H	Pump Fault (input terminal S1) (EF1)
000FH	Cooling Fan Error (FAn)	003AH	Pump Fault (input terminal S2) (EF2)
0014H	MEMOBUS/Modbus Communication Error (CE)	003FH	PLC Alarm (PA1)
0015H	Option Communication Error (bUS)	0040H	PLC Alarm (PA2)
0016H	Serial Communication Transmission Error (CALL)	0041H	Output Voltage Detection Fault (voF)
0017H	Motor Overload (oL1)	0042H	IGBT Maintenance Time (90%) (TrPC)
0018H	Drive Overload (oL2)	0043H	Soft Charge Bypass Relay Maintenance Time (LT-3)
001AH	Option Card External Fault (EF0)	0044H	IGBT Maintenance Time (50%) (LT-4)
001BH	Motor Switch command input during run (rUn)	0045H	Braking Transistor Overload (boL)
001DH	Serial Communication Transmission Error (CALL)	0046H	Low Flow (LOWFL)
001EH	Undertorque Detection 1 (UL3)	0047H	Accum Level (ACCUM)



## C.9 MEMOBUS/Modbus Data Table

Fault Code	Fault Name
0048H	Motor Overheat (NTC Input) (oH5)
004AH	High Flow (HIFLO)
004BH	Low Suction (LOSUC)
004CH	Loss of Prime (LOP)
004EH	Underload Detection 6 (UL6)
004FH	Waiting for Run (wRun)
0050H	AnalogFB Lost Switched to Net
0051H	Waiting for Master (NETSCAN)
0052H	Pump Cycling Pump Over Cycle (PoC)
0053H	Low Feedback Low FB Sensed
0054H	High Feedback High FB Sensed
0056H	Freq. Ref Pump Min (P1-06)
0057H	Freq. Ref Thrust (P4-12)
0058H	Low City Pressure
005AH	Low Water Level (LOWWL)
005BH	AnalogWL/SP Lost Switched to Net
005CH	Feedback Loss Wire Break

Fault Code	Fault Name
005DH	Net Flow Meter Lost Chk Source
005EH	R-DNE-Sx Remote Drv Dis
005FH	Low Suction Pressure
0059H	Anti Jam Active
0060H	Low Water In Tank
0061H	Temp Lost Geothermal Input
0062H	Geo Params Check Q2-05 to Q2-08
0063H	Clock Not Set (TIM)
0064H	HOA Battery Low (bAT)
0065H	HOA Time Deviation Error (TdE)
0066H	Setpoint Not Met (NMS)
0067H	Emergency Override FWD (EoF)
0068H	Emergency Override REV (Eor)
0069H	Feedback Loss Go To Freq b5-13
006CH	High Suction (HISUC)
006DH	Water Level Loss (WLL)
006EH	SuctionPres Loss (SPL)

## C.10 Enter Command

When writing parameters to the drive from the PLC using MEMOBUS/Modbus communication, parameter H5-11 determines whether an Enter command must be issued to enable these parameters. This section describes the types and functions of the Enter commands.

### ◆ Enter Command Types

The drive supports two types of Enter commands as shown in [Table C.7](#). An Enter command is enabled by writing 0 to register numbers 0900H or 0910H. It is only possible to write to these registers; attempting to read from these registers will cause an error.

**Table C.7 Enter Command Types**

Register No.	Description
0900H	Simultaneously writes data into the EEPROM (non-volatile memory) of the drive and enables the data in RAM. Parameter changes remain after cycling power.
0910H	Writes data in the RAM only. Parameter changes are lost when the drive is shut off.

**Note:** The EEPROM can only be written to 100,000 times, so it is recommended to limit the number of times writing to the EEPROM. The Enter command registers are write-only and if these registers are read, the register address will be invalid (Error code: 02H). An Enter command is not required when reference or broadcast data are sent to the drive.

### ◆ Enter Command Settings when Upgrading the Drive

When replacing previous Yaskawa drive models with the iQpump1000 and keeping the MEMOBUS/Modbus communications settings, set parameter H5-11 in accordance with the Enter command configuration in the older drive. H5-11 determines whether an Enter command is necessary to activate parameter changes in the drive.

- If upgrading from a G7, F7, or P7 series drive to a iQpump1000, set parameter H5-11 to 0.
- If upgrading from a V7 series drive to a iQpump1000, set parameter H5-11 to 1.

### ■ H5-11 and the Enter Command

An enter command is not required when writing registers 0000H to 001FH. Changes to those registers take effect immediately, independent of the setting in parameter H5-11.

H5-11 Settings	H5-11 = 0	H5-11 = 1
Drive being replaced	G7, F7, P7	V7
How parameter settings are enabled	When the Enter command is received from the master.	As soon as the value is changed.
Upper/lower limit check	Upper/lower limit check is performed, taking the settings of related parameters into account.	Checks only the upper/lower limits of the parameters that were changed.
Default value of related parameters	Not affected. The settings of related parameters remain unchanged. They must be changed manually if needed.	Default settings of related parameters are changed automatically.
Error handling when setting multiple parameters	Data is accepted even if one setting is invalid. The invalid setting will be discarded. No error message occurs.	Error occurs if only one setting is invalid. All data that was sent are discarded.

## C.11 Communication Errors

### ◆ MEMOBUS/Modbus Error Codes

A list of MEMOBUS/Modbus errors appears below.

When an error occurs, remove whatever caused the error and restart communications.

Error Code	Error Name
	Cause
01H	Function Code Error
	Attempted to set a function code from a PLC other than 03H, 08H, and 10H.
02H	Register Number Error
	<ul style="list-style-type: none"> <li>• A register number specified in the command message does not exist.</li> <li>• Attempted to send a broadcast message using other register numbers than 0001H or 0002H.</li> </ul>
03H	Bit Count Error
	<ul style="list-style-type: none"> <li>• Read data or write data is greater than 16 bits. Invalid command message quantity.</li> <li>• In a write message, the “Number of Data Items” contained within the message does not equal twice the amount of data words (i.e., the total of Data 1+ Data 2, etc.).</li> </ul>
21H	Data Setting Error
	<ul style="list-style-type: none"> <li>• Control data or parameter write data is outside the allowable setting range.</li> <li>• Attempted to write a contradictory parameter setting.</li> </ul>
22H	Write Mode Error
	<ul style="list-style-type: none"> <li>• During run, the user attempted to write a parameter that cannot be written to during run.</li> <li>• During an EEPROM memory data error (CPF06), the master attempted to write to a parameter other than A1-00 to A1-05, E1-03, or o2-04.</li> <li>• Attempted to write to read-only data.</li> </ul>
23H	DC Bus Undervoltage Write Error
	During an undervoltage situation, the master attempted to write to parameters that cannot be written to during undervoltage.
24H	Write Error During Parameter Process
	Master attempted writing to the drive while the drive was processing parameter data.
25H	Writing into EEPROM Disabled
	An attempt was made to write data into EEPROM by MEMOBUS/Modbus communications when writing EEPROM is not possible. (When this error code occurs, an error message is displayed and the drive continues operation.)

### ◆ Slave Not Responding

In the following situations, the slave drive will ignore the command message sent from the master, and not send a response message:

- When a communications error (overrun, framing, parity, or CRC-16) is detected in the command message.
- When the slave address in the command message and the slave address in the drive do not match (remember to set the slave address for the drive using H5-01).
- When the gap between two blocks (8-bit) of a message exceeds 24 bits.
- When the command message data length is invalid.

**Note:** If the slave address specified in the command message is 00H, all slaves execute the write function, but do not return response messages to the master.

## C.12 Self-Diagnostics

The drive has a built-in self-diagnosing function of the serial communication interface circuits. To perform the self-diagnosis function, use the following procedure.

**DANGER! Electrical Shock Hazard.** Do not connect or disconnect wiring while the power is on. Failure to comply will result in death or serious injury. Before servicing, disconnect all power to the equipment. The internal capacitor remains charged even after the power supply is turned off. The charge indicator LED will extinguish when the DC bus voltage is below 50 Vdc. To prevent electric shock, wait at least one minute after all indicators are OFF and measure the DC bus voltage level to confirm safe level.

1. Turn on the power to the drive.
2. Note the present terminal S6 function selection setting (H1-06) and set it for the communications test mode (H1-06 = 67).
3. Turn off the power to the drive.
4. With the power off, wire the drive as shown in [Figure C.8](#), connecting terminals R+ and S+, R- and S-, and S6 and SC.

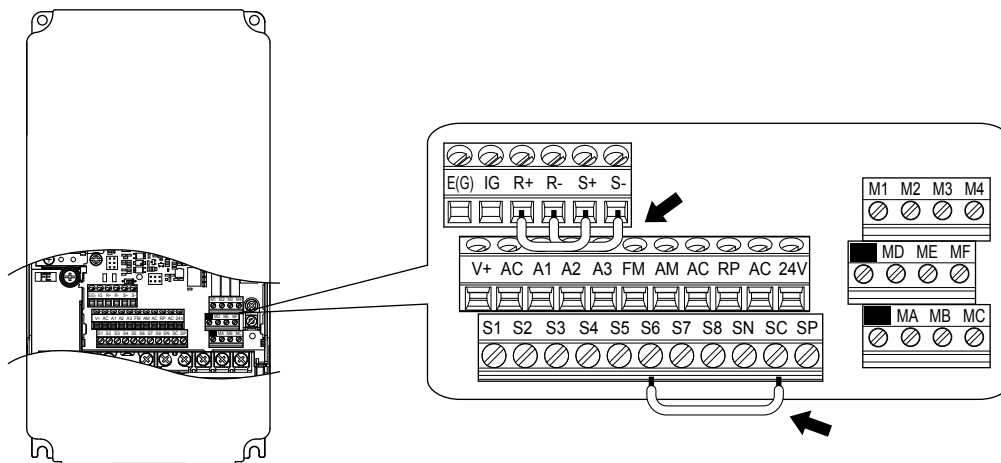

Figure C.8 Terminal Connections for Communication Self-Diagnostics

5. Set jumper S3 to source mode (internal power supply).
6. Turn the power to the drive back on.
7. During normal operation, the drive will display “Pass” to indicate that the communications test mode is operating normally.  
When a fault occurs, the drive will display “CE” on the keypad display.
8. Turn off the power supply.
9. Remove the wire jumpers from terminal R+, R-, S+, S-, and S6-SC. Reset jumper S3 to its original position and set terminal S6 to its original function.
10. Return to normal operation.

**This Page Intentionally Blank**

# Appendix: D

## Standards Compliance

---

This appendix explains the guidelines and criteria for maintaining CE and UL standards.

<b>D.1</b>	<b>EUROPEAN STANDARDS.....</b>	<b>488</b>
<b>D.2</b>	<b>UL AND CSA STANDARDS.....</b>	<b>496</b>

## D.1 European Standards



Figure D.1 CE Mark

The CE mark indicates compliance with European safety and environmental regulations. It is required for engaging in business and commerce in Europe.

European standards include the Machinery Directive for machine manufacturers, the Low Voltage Directive for electronics manufacturers, and the EMC guidelines for controlling noise.

This drive displays the CE mark based on the EMC guidelines and the Low Voltage Directive.

- **Low Voltage Directive:** 2014/35/EU
- **EMC Guidelines:** 2014/30/EU

Devices used in combination with this drive must also be CE certified and display the CE mark. When using drives displaying the CE mark in combination with other devices, it is ultimately the responsibility of the user to ensure compliance with CE standards. After setting up the device, verify that conditions meet European standards.

**Note:** 600 V class drives (models 5□□□□□□) are not compliant with European Standards.

### ◆ CE Low Voltage Directive Compliance

This drive has been tested according to European standard IEC/EN 61800-5-1:2007, and it fully complies with the Low Voltage Directive.

To comply with the Low Voltage Directive, be sure to meet the following conditions when combining this drive with other devices:

#### ■ Area of Use

Do not use drives in areas with pollution higher than degree 2 and overvoltage category 3 in accordance with IEC/EN 60664.

#### ■ Factory Recommended Branch Circuit Protection

Yaskawa recommends installing one of the following types of branch circuit protection to maintain compliance with UL508C. Semiconductor protective type fuses are preferred. Alternate branch circuit protection devices are also listed in [Table D.1](#).

**NOTICE:** If a fuse is blown or a Ground Fault Circuit Interrupter (GFCI) is tripped, check the wiring and the selection of peripheral devices to identify the cause. Contact Yaskawa before restarting the drive or the peripheral devices if the cause cannot be identified.

Table D.1 Factory Recommended Drive Branch Circuit Protection

Drive Model	Fuse Type	
	Manufacturer: Bussmann	
	Model	Fuse Ampere Rating (A)
<b>Three-Phase 200 V Class</b>		
2A0004	FWH-70B	70
2A0006	FWH-70B	70
2A0008	FWH-70B	70
2A0010	FWH-70B	70
2A0012	FWH-70B	70
2A0018	FWH-90B	90
2A0021	FWH-90B	90
2A0030	FWH-100B	100
2A0040	FWH-200B	200
2A0056	FWH-200B	200
2A0069	FWH-200B	200
2A0081	FWH-300A	300
2A0110	FWH-300A	300



Drive Model	Fuse Type	
	Manufacturer: Bussmann	
	Model	Fuse Ampere Rating (A)
2A0138	FWH-350A	350
2A0169	FWH-400A	400
2A0211	FWH-400A	400
2A0250	FWH-600A	600
2A0312	FWH-700A	700
2A0360	FWH-800A	800
2A0415	FWH-1000A	1000
<b>Three-Phase 400 V Class</b>		
4A0002	FWH-40B	40
4A0004	FWH-50B	50
4A0005	FWH-70B	70
4A0007	FWH-70B	70
4A0009	FWH-90B	90
4A0011	FWH-90B	90
4A0018	FWH-80B	80
4A0023	FWH-100B	100
4A0031	FWH-125B	125
4A0038	FWH-200B	200
4A0044	FWH-250A	250
4A0058	FWH-250A	250
4A0072	FWH-250A	250
4A0088	FWH-250A	250
4A0103	FWH-250A	250
4A0139	FWH-350A	350
4A0165	FWH-400A	400
4A0208	FWH-500A	500
4A0250	FWH-600A	600
4A0296	FWH-700A	700
4A0362	FWH-800A	800
4A0414	FWH-800A	800
4A0515	FWH-1000A	1000
4A0675	FWH-1200A	1200
4A0930	FWH-1200A	1200
4A1200	FWH-1600A	1600
<b>Three-Phase 600 V Class</b>		
5A0003 </>	FWP-50B	50
5A0004 </>	FWP-50B	50
5A0006 </>	FWP-60B	60
5A0009 </>	FWP-60B	60
5A0011 </>	FWP-70B	70
5A0017 </>	FWP-100B	100
5A0022 </>	FWP-100B	100
5A0027 </>	FWP-125A	125
5A0032 </>	FWP-125A	125
5A0041 </>	FWP-175A	175
5A0052 </>	FWP-175A	175

## D.1 European Standards

Drive Model	Fuse Type	
	Manufacturer: Bussmann	
	Model	Fuse Ampere Rating (A)
5A0062 </>	FWP-250A	250
5A0077 </>	FWP-250A	250
5A0099 </>	FWP-250A	250
5A0125 </>	FWP-350A	350
5A0145 </>	FWP-350A	350
5A0192 </>	FWP-600A	600
5A0242 </>	FWP-600A	600

<1> 600 V class drives are not compliant with European Standards.

### ■ Guarding Against Harmful Materials

When installing IP00/Open Type enclosure drives, use an enclosure that prevents foreign material from entering the drive from above or below.

### ■ Grounding

The drive is designed to be used in T-N (grounded neutral point) networks. If installing the drive in other types of grounded systems, contact your Yaskawa representative for instructions.

## ◆ EMC Guidelines Compliance

This drive is tested according to European standards IEC/EN 61800-3: 2004.

### ■ EMC Filter Installation

The following conditions must be met to ensure continued compliance with guidelines. [Refer to EMC Filters on page 493](#) for EMC filter selection.

#### Installation Method

Verify the following installation conditions to ensure that other devices and machinery used in combination with this drive also comply with EMC guidelines.

1. Install an EMC noise filter to the input side specified by Yaskawa for compliance with European standards.
2. Place the drive and EMC noise filter in the same enclosure.
3. Use braided shield cable for the drive and motor wiring, or run the wiring through a metal conduit.
4. Keep wiring as short as possible. Ground the shield on both the drive side and the motor side.

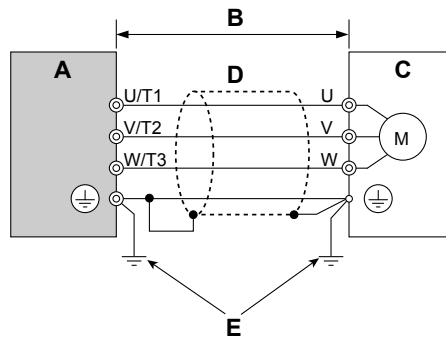

A – Drive

B – 10 m max cable length between drive and motor

C – Motor

D – Metal conduit

E – Ground wire should be as short as possible.

Figure D.2 Installation Method

5. Make sure the protective earthing conductor complies with technical standards and local safety regulations.

**WARNING!** *Electrical Shock Hazard. Because the leakage current exceeds 3.5 mA in models 4A0414 to 4A1200, IEC/EN 61800-5-1 states that either the power supply must be automatically disconnected in case of discontinuity of the protective earthing conductor, or a protective earthing conductor with a cross-section of at least 10 mm<sup>2</sup> (Cu) or 16 mm<sup>2</sup> (Al) must be used. Failure to comply may result in death or serious injury.*

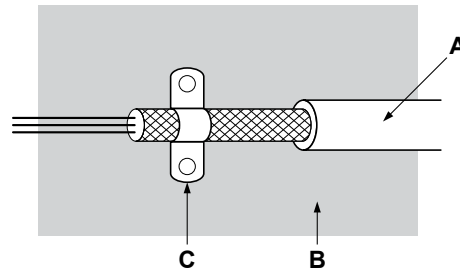

A – Braided shield cable  
B – Metal panel

C – Cable clamp (conductive)

Figure D.3 Ground Area

6. Connect a DC link choke to minimize harmonic distortion.

### Three-Phase 200 V / 400 V Class

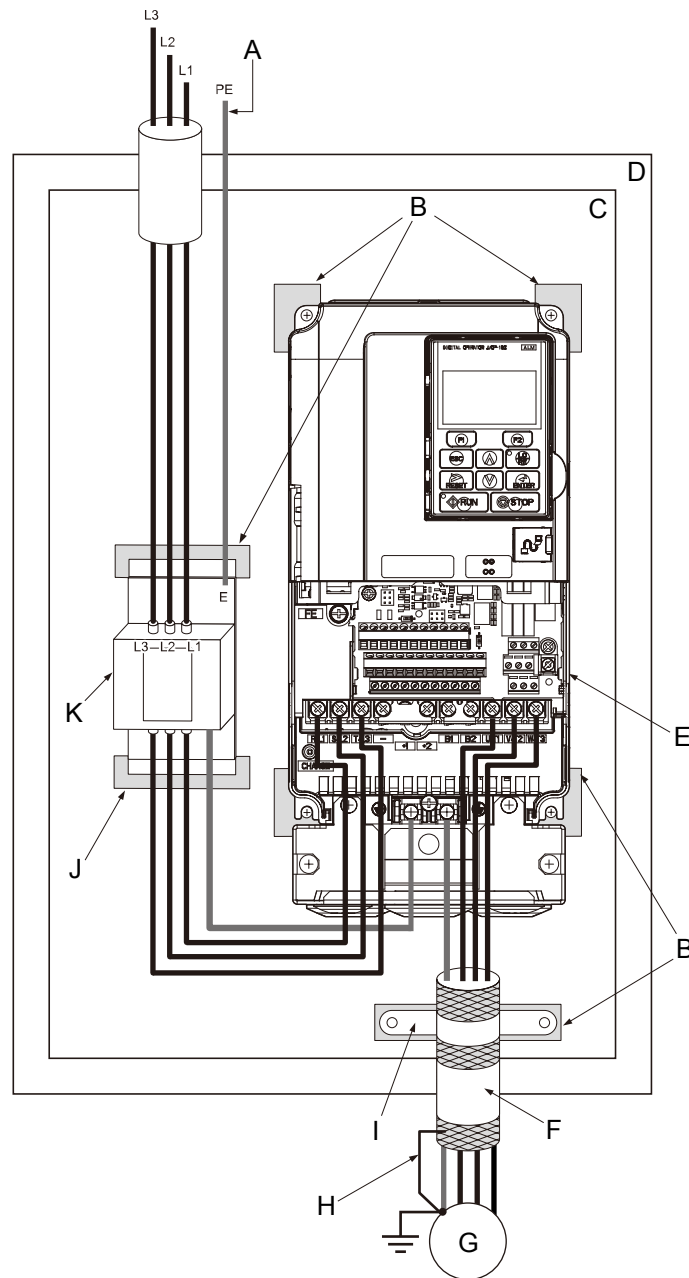

- |  |  |
|--|--|
| <b>A</b> – Make sure the ground wire is grounded           | <b>G</b> – Motor                                       |
| <b>B</b> – Grounding surface (remove any paint or sealant) | <b>H</b> – Cable shield ground                         |
| <b>C</b> – Metal plate                                     | <b>I</b> – Cable clamp                                 |
| <b>D</b> – Enclosure panel                                 | <b>J</b> – Ground plate (scrape off any visible paint) |
| <b>E</b> – Drive   | <b>K</b> – EMC noise filter                            |
| <b>F</b> – Motor cable (braided shield cable, max. 10 m)   |  |

Figure D.4 EMC Filter and Drive Installation for CE Compliance (Three-Phase 200 V / 400 V Class)

## ■ EMC Filters

Install the drive with the EMC filters listed in [Table D.2](#) to comply with the EN61800-3 requirements.

**Table D.2 EN61800-3 Filters**

Drive Model	Filter Data (Manufacturer: Schaffner)					Figure
	Type	Rated Current (A)	Weight (lb)	Dimensions [W x D x H] (in)	Y x X (in)	
<b>Three-Phase 200 V Class</b>						
2A0004	FS5972-10-07	10	2.6	5.6 × 1.8 × 13.0	4.5 × 12.3	1
2A0006						
2A0008						
2A0010	FS5972-18-07	18	2.9	5.6 × 1.8 × 13.0	4.5 × 12.3	
2A0012						
2A0018						
2A0021	FS5972-35-07	35	4.6	8.1 × 2.0 × 14.0	6.9 × 13.2	
2A0030						
2A0040						
2A0056	FS5972-60-07	60	8.8	9.3 × 2.6 × 16.1	8.1 × 15.4	
2A0069	FS5972-100-35	100	7.5	3.5 × 5.9 × 13.0	2.6 × 10.0	2
2A0081						
2A0110						
2A0138	FS5972-170-40	170	13.2	4.7 × 6.7 × 17.8	4.0 × 14.4	
2A0169						
2A0211						
2A0250	FS5972-250-37	250	25.8	5.1 × 9.5 × 24.0	3.5 × 19.6	
2A0312						
2A0360						
2A0415	FS5972-410-99	410	23.1	10.2 × 4.5 × 15.2	9.3 × 4.7	3
2A0360	FS5972-600-99	600	24.3	10.2 × 5.3 × 15.2	9.3 × 4.7	
2A0415						
<b>Three-Phase 400 V Class</b>						
4A0002	FS5972-10-07	10	2.7	5.6 × 1.8 × 13.0	4.5 × 12.3	1
4A0004						
4A0005						
4A0007						
4A0009	FS5972-18-07	18	2.9	5.6 × 1.8 × 13.0	4.5 × 12.3	
4A0011						
4A0018						
4A0023	FS5972-35-07	35	4.6	8.1 × 2.0 × 14.0	6.9 × 13.2	
4A0031						
4A0038						
4A0044	FS5972-60-07	60	8.8	9.3 × 2.6 × 16.1	8.0 × 15.4	
4A0058						
4A0072						
4A0088	FS5972-100-35	100	16.5	3.5 × 5.9 × 13.0	2.6 × 10.0	2
4A0103						
4A0139						
4A0165	FS5972-170-35	170	10.4	4.7 × 6.7 × 17.8	4.0 × 14.4	
4A0208						
4A0250						
4A0296	FS5972-250-37	250	25.8	5.1 × 9.5 × 24.0	3.5 × 19.6	
4A0362						
4A0414						
4A0515	FS5972-410-99	410	23.1	10.2 × 4.5 × 15.2	9.3 × 4.7	3
4A0675						
4A0675						
4A0675	FS5972-600-99	600	24.3	10.2 × 5.3 × 15.2	9.3 × 4.7	
4A0675						
4A0675						
4A0675	FS5972-800-99	800	69.4	11.8 × 6.3 × 28.2	10.8 × 8.3	

## D.1 European Standards

Drive Model	Filter Data (Manufacturer: Schaffner)					Figure
	Type	Rated Current (A)	Weight (lb)	Dimensions [W x D x H] (in)	Y x X (in)	
4A0930	FS5972-600-99 <1>	600	24.3	10.2 × 5.3 × 15.2	9.3 × 4.7	-
4A1200	FS5972-800-99 <1>	800	69.4	11.8 × 6.3 × 28.2	10.8 × 8.3	

<1> Connect two of the same filters in parallel.

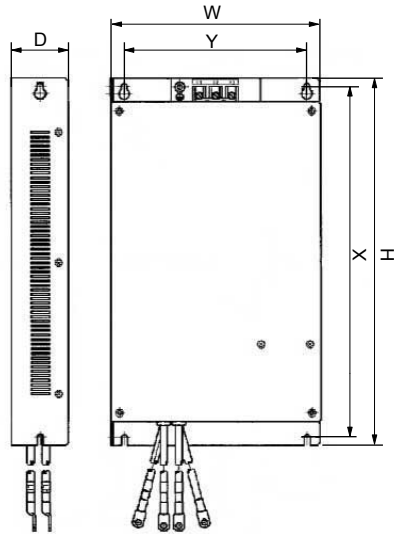

Figure 1

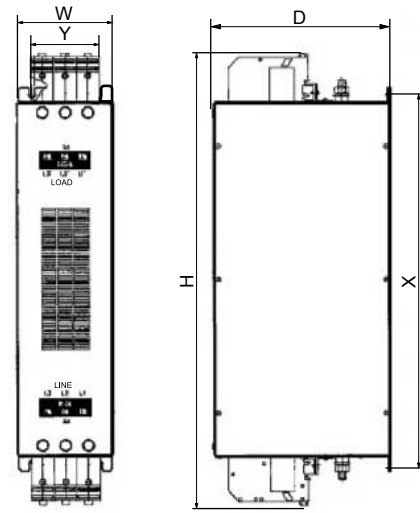

Figure 2

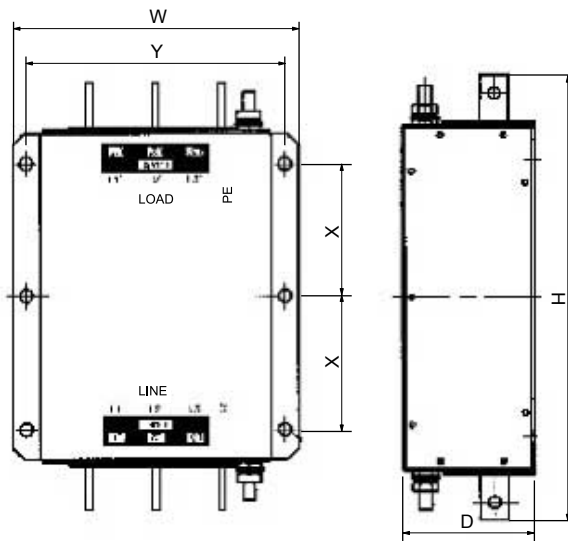

Figure 3

Figure D.5 EMC Filter Dimensions

## ■ DC Link Chokes for IEC/EN 61000-3-2 Compliance

Table D.3 DC Link Chokes for Harmonic Reduction

Drive Model	DC Link Chokes	
	Model	Rating
<b>200 V Three-Phase Units</b>		
2A0004	UZDA-B	5.4 A 8 mH
2A0006		
<b>400 V Three-Phase Units</b>		
4A0002	UZDA-B	3.2 A 28 mH
4A0004		

**Note:** DC link chokes are not required for other models to comply with EMC.

## D.2 UL and CSA Standards

### ◆ UL Standards Compliance

The UL/cUL mark applies to products in the United States and Canada. It indicates that UL has performed product testing and evaluation, and determined that their stringent standards for product safety have been met. For a product to receive UL certification, all components inside that product must also receive UL certification.



Figure D.6 UL/cUL Mark

This drive is tested in accordance with UL standard UL508C and complies with UL requirements. The conditions described below must be met to maintain compliance when using this drive in combination with other equipment:

#### ■ Installation Area

Do not install the drive to an area greater than pollution degree 2 (UL standard).

#### ■ Main Circuit Terminal Wiring

Yaskawa recommends using closed-loop crimp terminals on all drive models. To maintain UL/cUL approval, UL Listed closed-loop crimp terminals are specifically required when wiring the drive main circuit terminals on models 2A0110 to 2A0415, 4A0058 to 4A1200, and 5A0041 to 5A0242. Use only the tools recommended by the terminal manufacturer for crimping. *Refer to Closed-Loop Crimp Terminal Size on page 496* for closed-loop crimp terminal recommendations.

#### Closed-Loop Crimp Terminal Recommendations

To maintain UL/cUL approval, UL Listed closed-loop crimp terminals are specifically required when wiring the drive main circuit terminals on models 2A0110 to 2A0415, 4A0058 to 4A1200, and 5A0041 to 5A0242. Use only the tools recommended by the terminal manufacturer for crimping. Yaskawa recommends crimp terminals made by JST and Tokyo DIP (or equivalent) for the insulation cap. *Table D.4* matches the wire gauges and terminal screw sizes with Yaskawa-recommended crimp terminals, tools, and insulation caps. Refer to the appropriate Wire Gauge and Torque Specifications table for the wire gauge and screw size for your drive model. Place orders with a Yaskawa representative or the Yaskawa sales department.

Wire gauge values shown in ***bold italic*** are the recommended values. Refer to local codes for proper selections.

Table D.4 Closed-Loop Crimp Terminal Size

Drive Model	Wire Gauge (AWG, kcmil)		Screw Size	Crimp Terminal Model Number	Tool		Insulation Cap Model No.	Code <1>
	R/L1, S/L2, T/L3	U/T1, V/T2, W/T3			Machine No.	Die Jaw		
<b>200 V Class</b>								
2A0004 2A0006 2A0008 2A0010	<i>14</i>		M4	R2-4	YA-4	AD-900	TP-003	100-054-028
	12			R5.5-4			TP-005	100-054-029
	10							
2A0012	14	<i>14</i>	M4	R2-4	YA-4	AD-900	TP-003	100-054-028
	<i>12</i>	12		R5.5-4			TP-005	100-054-029
	10							
2A0018	–	14	M4	R2-4	YA-4	AD-900	TP-003	100-054-028
	12			R5.5-4			TP-005	100-054-029
	<i>10</i>							
2A0021	12		M4	R5.5-4	YA-4	AD-900	TP-005	100-054-029
	<i>10</i>							
2A0030	10		M4	R5.5-4	YA-4	AD-900	TP-005	100-054-029
	<i>8</i>			8-4		AD-901	TP-008	100-054-031
	6			14-NK4		AD-902	TP-014	100-054-033



Drive Model	Wire Gauge (AWG, kcmil)		Screw Size	Crimp Terminal Model Number	Tool		Insulation Cap Model No.	Code <1>	
	R/L1, S/L2, T/L3	U/T1, V/T2, W/T3			Machine No.	Die Jaw			
2A0040	8	8	M4	8-4	YA-4	AD-901	TP-008	100-054-031	
	6	6		14-NK4		AD-902	TP-014	100-054-033	
2A0056	6		M6	R14-6	YA-5	AD-952	TP-014	100-051-261	
	4			R22-6		AD-953	TP-022	100-051-262	
2A0069	4		M8	R22-8	YA-5	AD-953	TP-022	100-051-263	
	3			R38-8		AD-954	TP-038	100-051-264	
2A0081	3		M8	R38-8	YA-5	AD-954	TP-038	100-051-264	
	2								
2A0110	3		M8	R38-8	YA-5	AD-954	TP-038	100-051-264	
	2								
	1								
2A0138	1/0		M10	R60-8	YA-5	AD-955	TP-060	100-051-265	
	1			R38-10		YF-1 YET-300-1	TD-321, TD-311	TP-060	100-061-114
	2/0			R60-10			70-10		TD-323, TD-312
2A0169	2/0	–	M10	70-10	YF-1 YET-300-1	TD-323, TD-312	TP-080	100-054-036	
	3/0			80-10				100-051-267	
	4/0			R100-10				TD-324, TD-312	TP-100
2A0211	1/0 × 2P		M10	R60-10	YF-1 YET-300-1	TD-321, TD-311	TP-060	100-051-266	
	2/0 × 2P			70-10		TD-323, TD-312	TP-080	100-054-036	
2A0250	3/0 × 2P		M12	80-L12	YF-1 YET-300-1	TD-323, TD-312	TP-080	100-051-558	
	4/0 × 2P			100-L12		TD-324, TD-312	TP-100	100-051-560	
	–	250 × 2P		150-L12		TD-325, TD-313	TP-150	100-051-562	
	250	–		R150-12			TP-150	100-051-273	
	300								
2A0312	3/0 × 2P	3/0 × 2P	M12	80-L12	YF-1 YET-300-1	TD-323, TD-312	TP-080	100-051-558	
	4/0 × 2P	4/0 × 2P		100-L12		TD-324, TD-312	TP-100	100-051-560	
	250 × 2P			150-L12		TD-325, TD-313	TP-150	100-051-562	
	300 × 2P								
2A0360	4/0 × 2P	4/0 × 2P	M12	100-L12	YF-1 YET-300-1	TD-324, TD-312	TP-100	100-051-560	
	250 × 2P	250 × 2P		150-L12		TD-325, TD-313	TP-150	100-051-562	
	300 × 2P			180-L12		TD-327, TD-314	TP-200	100-066-688	
	350 × 2P			200-L12				100-051-564	
	400 × 2P			325-12		TD-328, TD-315	TP-325	100-051-277	
	500 × 2P								
	600	600 × 2P							
2A0415	250 × 2P	–	M12	150-L12	YF-1 YET-300-1	TD-325, TD-313	TP-150	100-051-562	
	300 × 2P	300 × 2P		180-L12		TD-327, TD-314	TP-200	100-066-688	
	350 × 2P	350 × 2P		200-L12				100-051-564	
	400 × 2P			325-12		TD-328, TD-315	TP-325	100-051-277	
	500 × 2P								
	600 × 2P								

## D.2 UL and CSA Standards

Drive Model	Wire Gauge (AWG, kcmil)		Screw Size	Crimp Terminal Model Number	Tool		Insulation Cap Model No.	Code <?>	
	R/L1, S/L2, T/L3	U/T1, V/T2, W/T3			Machine No.	Die Jaw			
<b>400 V Class</b>									
4A0002 4A0004 4A0005 4A0007 4A0009	14		M4	R2-4	YA-4	AD-900	TP-003	100-054-028	
	12			R5.5-4			TP-005	100-054-029	
	10								
4A0011	14	14	M4	R2-4	YA-4	AD-900	TP-003	100-054-028	
	12	12		R5.5-4			TP-005	100-054-029	
	10								
4A0018	12		M4	R5.5-4	YA-4	AD-900	TP-005	100-054-029	
	10			8-4			AD-901	TP-008	100-054-031
	8			14-NK4			AD-902	TP-014	100-054-033
	6								
4A0023	10		M4	R5.5-4	YA-4	AD-900	TP-005	100-054-029	
	8			8-4			AD-901	TP-008	100-054-031
	6			14-NK4			AD-902	TP-014	100-054-033
4A0031	-	10	M5	R5.5-5	YA-4	AD-900	TP-005	100-054-030	
	8			R8-5			AD-901	TP-008	100-054-032
	6			R14-5			AD-902	TP-014	100-054-034
4A0038	8	8	M5	R8-5	YA-4	AD-901	TP-008	100-054-032	
	6	6		R14-5			AD-902	TP-014	100-054-034
4A0044	6		M6	R14-6	YA-5	AD-952	TP-014	100-051-261	
	4			R22-6			AD-953	TP-022	100-051-262
4A0058	6		M8	R14-8	YA-5	AD-952	TP-014	100-054-035	
	4			R22-8			AD-953	TP-022	100-051-263
4A0072	4		M8	R22-8	YA-5	AD-953	TP-022	100-051-263	
	3			R38-8			AD-954	TP-038	100-051-264
4A0088	3		M8	R38-8	YA-5	AD-954	TP-038	100-051-264	
	2						R60-8	AD-955	TP-060
	1								
	1/0								
4A0103	2		M8	R38-8	YA-5	AD-954	TP-038	100-051-264	
	1	1					R60-8	AD-955	TP-060
	1/0	1/0							
4A0139	1/0		M10	R60-10	YF-1 YET-300-1	TD-321, TD-311	TP-060	100-051-266	
	2/0	2/0		70-10			TD-323, TD-312	TP-080	100-054-036
	3/0	3/0		80-10					100-051-267
	4/0			R100-10			TD-324, TD-312	TP-100	100-051-269
4A0165	3/0		M10	80-10	YF-1 YET-300-1	TD-323, TD-312	TP-080	100-051-267	
	4/0			R100-10			TD-324, TD-312	TP-100	100-051-269
4A0208	2 × 2P		M10	38-L10	YF-1 YET-150-1	TD-224, TD-212	TP-038	100-051-556	
	1 × 2P						80-L10	TD-227, TD-214	TP-080
	3/0 × 2P			R100-10				TD-228, TD-214	TP-100
	4/0			R150-10			TD-229, TD-215	TP-150	100-051-272
	250								
300									

Drive Model	Wire Gauge (AWG, kcmil)		Screw Size	Crimp Terminal Model Number	Tool		Insulation Cap Model No.	Code <1>
	R/L1, S/L2, T/L3	U/T1, V/T2, W/T3			Machine No.	Die Jaw		
4A0250	1 × 2P	–	M10	38-L10	YF-1 YET-150-1	TD-224, TD-212	TP-038	100-051-556
	3/0 × 2P			80-L10		TD-227, TD-214	TP-080	100-051-557
	4/0 × 2P			100-L10		TD-228, TD-214	TP-100	100-051-559
	250 × 2P			150-L10		TD-229, TD-215	TP-150	100-051-561
	300			R150-10		TP-150	100-051-272	
	350			180-10	YF-1 YET-300-1	TD-327, TD-314	TP-200	100-066-687
	<b>400</b>			200-10		100-051-563		
	500			325-10		TD-328, TD-315	TP-325	100-051-565
	600							
4A0296	3/0 × 2P		M12	80-L12	YF-1 YET-300-1	TD-323, TD-312	TP-080	100-051-558
	4/0 × 2P			100-L12		TD-324, TD-312	TP-100	100-051-560
	250 × 2P			150-L12		TD-325, TD-313	TP-150	100-051-562
	300 × 2P			180-L12		TD-327, TD-314	TP-200	100-066-688
	–	350 × 2P		180-12				100-066-689
	350	–		R200-12				100-051-275
	400			325-12		TD-328, TD-315	TP-325	100-051-277
	<b>500</b>							
	600							
4A0362	3/0 × 2P		M12	80-L12	YF-1 YET-300-1	TD-323, TD-312	TP-080	100-051-558
	<b>4/0 × 2P</b>			100-L12		TD-324, TD-312	TP-100	100-051-560
	250 × 2P			150-L12		TD-325, TD-313	TP-150	100-051-562
	300 × 2P			180-L12		TD-327, TD-314	TP-200	100-066-688
	350 × 2P			200-L12				100-051-564
	400 × 2P			325-12		TD-328, TD-315	TP-325	100-051-277
	500							
	600							
4A0414	4/0 × 2P		M12	100-L12	YF-1 YET-300-1	TD-324, TD-312	TP-100	100-051-560
	250 × 2P			150-L12		TD-325, TD-313	TP-150	100-051-562
	<b>300 × 2P</b>							
4A0515	<b>3/0 × 4P</b>	3/0 × 4P	M12	80-L12	YF-1 YET-300-1	TD-323, TD-312	TP-080	100-051-558
	4/0 × 4P	<b>4/0 × 4P</b>		100-L12		TD-324, TD-312	TP-100	100-051-560
	250 × 4P			150-L12		TD-325, TD-313	TP-150	100-051-562
	300 × 2P							
4A0675	4/0 × 4P		M12	100-L12	YF-1 YET-300-1	TD-324, TD-312	TP-100	100-051-560
	250 × 4P			150-L12		TD-325, TD-313	TP-150	100-051-562
	<b>300 × 4P</b>							
4A0930	3/0 × 8P		M12	80-L12	YF-1 YET-300-1	TD-323, TD-312	TP-080	100-051-558
	<b>4/0 × 8P</b>			100-L12		TD-324, TD-312	TP-100	100-051-560
	250 × 8P			150-L12		TD-325, TD-313	TP-150	100-051-562
	300 × 8P							

## D.2 UL and CSA Standards

Drive Model	Wire Gauge (AWG, kcmil)		Screw Size	Crimp Terminal Model Number	Tool		Insulation Cap Model No.	Code <1>
	R/L1, S/L2, T/L3	U/T1, V/T2, W/T3			Machine No.	Die Jaw		
4A1200	4/0 × 8P		M12	100-L12	YF-1 YET-300-1	TD-324, TD-312	TP-100	100-051-560
	250 × 8P			150-L12		TD-325, TD-313	TP-150	100-051-562
	300 × 8P							

<1> Codes refer to a set of three crimp terminals and three insulation caps. Prepare input and output wiring using two sets for each connection.

Example 1: Models with 300 kcmil for both input and output require one set for input terminals and one set for output terminals, so the user should order two sets of [100-051-272].

Example 2: Models with 4/0 AWG × 2P for both input and output require two sets for input terminals and two sets for output terminals, so the user should order four sets of [100-051-560].

**Note:** Use crimp insulated terminals or insulated shrink tubing for wiring connections. Wires should have a continuous maximum allowable temperature of 75 °C 600 Vac UL-approved vinyl-sheathed insulation.

### Factory Recommended Branch Circuit Protection for UL Compliance

**NOTICE:** If a fuse is blown or a Ground Fault Circuit Interrupter (GFCI) is tripped, check the wiring and the selection of the peripheral devices. Check the wiring and the selection of peripheral devices to identify the cause. Contact Yaskawa before restarting the drive or the peripheral devices if the cause cannot be identified.

Yaskawa recommends installing one of the following types of branch circuit protection to maintain compliance with UL508C. Semiconductor protective type fuses are preferred. Alternate branch circuit protection devices are also listed in the tables below.

**Table D.5 Factory Recommended Drive Branch Circuit Protection (Normal Duty)**

Drive Model	Normal Duty					
	Nominal Output Power HP	AC Drive Input Amps	MCCB Rating Amps <1>	Time Delay Fuse Rating Amps <2>	Non-time Delay Fuse Rating Amps <3>	Busmann Semiconductor Fuse Rating (Fuse Ampere) <4>
<b>200 V Class</b>						
2A0004	0.75	3.9	15	6.25	10	FWH-70B (70)
2A0006	1 - 1.5	7.3	15	12	20	FWH-70B (70)
2A0008	2	8.8	15	15	25	FWH-70B (70)
2A0010	3	10.8	20	17.5	30	FWH-70B (70)
2A0012	3	13.9	25	20	40	FWH-70B (70)
2A0018	5	18.5	35	30	50	FWH-90B (90)
2A0021	7.5	24	45	40	70	FWH-90B (90)
2A0030	10	37	60	60	110	FWH-100B (100)
2A0040	15	52	100	90	150	FWH-200B (200)
2A0056	20	68	125	110	200	FWH-200B (200)
2A0069	25	80	150	125	225	FWH-200B (200)
2A0081	30	96	175	150	275	FWH-300A (300)
2A0110	40	111	200	175	300	FWH-300A (300)
2A0138	50	136	250	225	400	FWH-350A (350)
2A0169	60	164	300	250	450	FWH-400A (400)
2A0211	75	200	400	350	600	FWH-400A (400)
2A0250	100	271	500	450	800	FWH-600A (600)
2A0312	125	324	600	500	800	FWH-700A (700)
2A0360	150	394	700	600	1000 <5>	FWH-800A (800)
2A0415	175	471	900	800	1400 <5>	FWH-1000A (1000)
<b>400 V Class</b>						
4A0002	1	2.1	15	3.5	6	FWH-40B (40)
4A0004	2	4.3	15	7.5	12	FWH-50B (50)
4A0005	3	5.9	15	10	17.5	FWH-70B (70)

Drive Model	Normal Duty					
	Nominal Output Power HP	AC Drive Input Amps	MCCB Rating Amps <1>	Time Delay Fuse Rating Amps <2>	Non-time Delay Fuse Rating Amps <3>	Bussmann Semiconductor Fuse Rating (Fuse Ampere) <4>
4A0007	3	8.1	15	12	20	FWH-70B (70)
4A0009	5	9.4	15	15	25	FWH-90B (90)
4A0011	7.5	14	25	20	40	FWH-90B (90)
4A0018	10	20	40	35	60	FWH-80B (80)
4A0023	15	24	45	40	70	FWH-100B (100)
4A0031	20	38	75	60	110	FWH-125B (125)
4A0038	25	44	75	75	125	FWH-200B (200)
4A0044	30	52	100	90	150	FWH-250A (250)
4A0058	40	58	100	100	150	FWH-250A (250)
4A0072	50	71	125	110	200	FWH-250A (250)
4A0088	60	86	150	150	250	FWH-250A (250)
4A0103	75	105	200	175	300	FWH-250A (250)
4A0139	100	142	250	225	400	FWH-350A (350)
4A0165	125	170	300	250	500	FWH-400A (400)
4A0208	150	207	400	350	600	FWH-500A (500)
4A0250	200	248	450	400	700	FWH-600A (600)
4A0296	250	300	600	500	800	FWH-700A (700)
4A0362	300	346	600	600	1000 <5>	FWH-800A (800)
4A0414	350	410	800	700	1200 <5>	FWH-800A (800)
4A0515	400 - 450	465	900	800	1350 <5>	FWH-1000A (1000)
4A0675	500 - 600	657	1200	1100 <5>	1800 <5>	FWH-1200A (1200)
4A0930	700 - 800	922	Not Applicable			FWH-1200A (1200)
4A1200	900 - 1000	1158	Not Applicable			FWH-1600A (1600)
600 V Class						
5A0003	2	3.6	15	6.25	10	FWP-50B (50)
5A0004	3	5.1	15	8	15	FWP-50B (50)
5A0006	5	8.3	15	12	20	FWP-60B (60)
5A0009	7.5	12	20	20	35	FWP-60B (60)
5A0011	10	16	30	25	45	FWP-70B (70)
5A0017	15	23	40	40	60	FWP-100B (100)
5A0022	20	31	60	50	90	FWP-100B (100)
5A0027	25	38	75	60	110	FWP-125A (125)
5A0032	30	45	75	75	125	FWP-125A (125)
5A0041	40	44	75	75	125	FWP-175A (175)
5A0052	50	54	100	90	150	FWP-175A (175)
5A0062	60	66	125	110	175	FWP-250A (250)
5A0077	75	80	150	125	225	FWP-250A (250)
5A0099	100	108	175	175	300	FWP-250A (250)
5A0125	125	129	225	225	350	FWP-350A (350)
5A0145	150	158	300	275	450	FWP-350A (350)
5A0192	200	228	400	350	600	FWP-600A (600)
5A0242	250	263	500	450	700	FWP-600A (600)

- <1> Maximum MCCB Rating is 15 A, or 200 % of drive input current rating, whichever is larger. MCCB voltage rating must be 600 VAC or greater.
- <2> Maximum Time Delay fuse is 175% of drive input current rating. This covers any Class CC, J or T class fuse.
- <3> Maximum Non-time Delay fuse is 300% of drive input current rating. This covers any CC, J or T class fuse.
- <4> When using semiconductor fuses, Bussman FWH and FWP are required for UL compliance. Select FWH for 200 V Class and 400 V Class models and FWP fuses for 600 V models.

## D.2 UL and CSA Standards

<5> Class L fuse is also approved for this rating.

### Wiring Fuses for Models 4A0930 and 4A1200

**NOTICE:** If a fuse is blown or an Ground Fault Circuit Interrupter (GFCI) is tripped, check the wiring and the selection of peripheral devices to identify the cause. Contact Yaskawa before restarting the drive or the peripheral devices if the cause cannot be identified.

Install a fuse on the input side to protect drive wiring and prevent other secondary damage. Wire the fuse so that leakage current in the upper controller power supply will trigger the fuse and shut off the power supply.

Select the appropriate fuse from [Table 3.2](#).

**Table D.6 Input Fuses for Models 4A0930 and 4A1200**

Voltage Class	Model	Selection			Input Fuse (Example)			
		Input Voltage	Current	Pre-arc I <sup>2</sup> t (A <sup>2</sup> s)	Model	Manufacturer	Rating	Pre-arc I <sup>2</sup> t (A <sup>2</sup> s)
Three-Phase 400 V Class	4A0930	480 V	1500 A	140000 to 3100000	CS5F-1200	Fuji Electric	AC500 V, 1200 A	276000
					FWH-1200A	Bussman	AC500 V, 1200 A	–
	4A1200	480 V	1500 A	320000 to 3100000	CS5F-1500	Fuji Electric	AC500 V, 1500 A	351000
					FWH-1600A	Bussman	AC500 V, 1600 A	–

### ■ Low Voltage Wiring for Control Circuit Terminals

Wire low voltage wires with NEC Class 1 circuit conductors. Refer to national state or local codes for wiring. The external power supply shall be a UL listed Class 2 power supply source or equivalent only.

**Table D.7 Control Circuit Terminal Power Supply**

Input / Output	Terminal Signal	Power Supply Specifications
Digital inputs	S1 to S8, SC	Use the internal LVLC power supply of the drive. Use class 2 for external power supply.
Analog inputs / outputs	+V, A1, A2, A3, AC, AM, FM	Use the internal LVLC power supply of the drive. Use class 2 for external power supply.

### ■ Drive Short Circuit Rating

The drive is suitable for use on a circuit capable of delivering not more than 100,000 RMS symmetrical Amperes, 240 Vac maximum (200 V Class), 480 Vac maximum (400 V Class), and 600 Vac maximum (600 V Class) when protected by Bussmann Type FWH or FWP fuses as specified in [Factory Recommended Branch Circuit Protection](#) on page [488](#).

## ◆ CSA Standards Compliance



Figure D.7 CSA Mark

### ■ CSA for Industrial Control Equipment

The drive is CSA-certified as Industrial Control Equipment Class 3211.

Specifically, the drive is certified to: CAN/CSA C22.2 No. 04-04 and CAN/CSA C22.2 No.14-05.

## ◆ Drive Motor Overload Protection

Set parameter E2-01 (motor rated current) to the appropriate value to enable motor overload protection. The internal motor overload protection is UL Listed and in accordance with the NEC and CEC.

### ■ E2-01: Motor Rated Current

Setting Range: Model-dependent

Default Setting: Model-dependent

Parameter E2-01 protects the motor when parameter L1-01 is not set to 0. The default for L1-01 is 1, which enables protection for standard induction motors.

If Auto-Tuning has been performed successfully, the motor data entered to T1-04 is automatically written to parameter E2-01. If Auto-Tuning has not been performed, manually enter the correct motor rated current to parameter E2-01.

### ■ L1-01: Motor Overload Protection Selection

The drive has an electronic overload protection function (oL1) based on time, output current, and output frequency that protects the motor from overheating. The electronic thermal overload function is UL-recognized, so it does not require an external thermal relay for single motor operation.

This parameter selects the motor overload curve used according to the type of motor applied.

Table D.8 Overload Protection Settings

Setting	Description	
0	Disabled	Disabled the internal motor overload protection of the drive.
1	Standard fan-cooled motor (60 Hz default)	Selects protection characteristics for a standard self-cooled motor with limited cooling capabilities when running below the rated speed. The motor overload detection level (oL1) is automatically reduced when running below the motor rated speed.
2	Drive duty motor with a speed range of 1:10	Selects protection characteristics for a motor with self-cooling capability within a speed range of 10:1. The motor overload detection level (oL1) is automatically reduced when running below 1/10 of the motor rated speed.
3	Vector motor with a speed range of 1:100	Selects protection characteristics for a motor capable of cooling itself at any speed including zero speed (externally cooled motor). The motor overload detection level (oL1) is constant over the entire speed range.
6	Standard fan-cooled motor (50 Hz)	Selects protection characteristics for a standard self-cooled motor with limited cooling capabilities when running below the rated speed. The motor overload detection level (oL1) is automatically reduced when running below the motor rated speed.

When connecting the drive to more than one motor for simultaneous operation, disable the electronic overload protection (L1-01 = 0) and wire each motor with its own motor thermal overload relay.

Enable motor overload protection (L1-01 ≠ 0) when connecting the drive to a single motor, unless another motor overload preventing device is installed. The drive electronic thermal overload function causes an oL1 fault, which shuts off the output of the drive and prevents additional overheating of the motor. The motor temperature is continually calculated while the drive is powered up.

■ **L1-02: Motor Overload Protection Time**

Setting Range: 0.1 to 5.0 min

Factory Default: 1.0 min

Parameter L1-02 determines how long the motor is allowed to operate before the oL1 fault occurs when the drive is running a hot motor at 60 Hz and at 150% of the full load amp rating (E2-01) of the motor. Adjusting the value of L1-02 can shift the set of oL1 curves up the y axis of the diagram below, but will not change the shape of the curves.

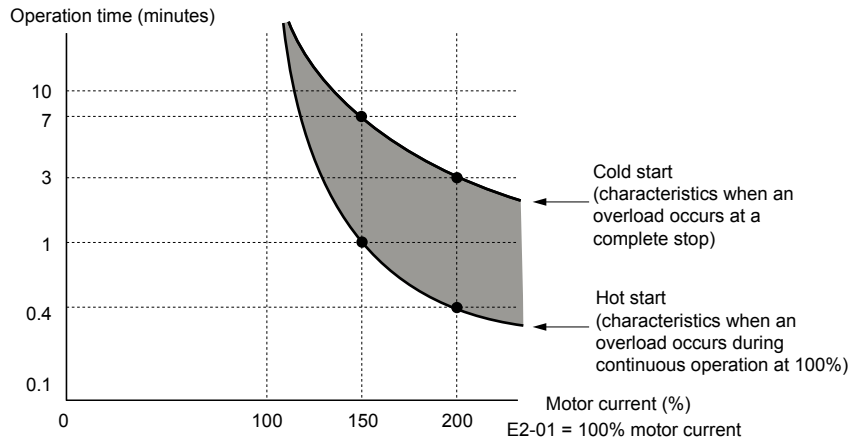

Figure D.8 Motor Overload Protection Time

◆ **Precautionary Notes on External Heatsink (IP00/Open Type Enclosure)**

When using an external heatsink, UL compliance requires covering exposed capacitors in the main circuit to prevent injury to surrounding personnel.

The portion of the external heatsink that projects out can be protected with the enclosure or with the appropriate capacitor cover after completing drive installation. Use [Table D.9](#) to match drive models with available capacitor covers. Order capacitor covers from a Yaskawa representative or directly from the Yaskawa sales department.

Table D.9 Capacitor Cover

Drive Model	Code Number	Figure
2A0110	100-061-273	<i>Figure D.9</i>
2A0138	100-061-274	
2A0169	100-061-275	
2A0211		
2A0250	100-061-277	
2A0312		
2A0360	100-061-278	
2A0415		
4A0058	100-061-273	
4A0072	100-061-274	
4A0088	100-061-276	
4A0103		
4A0139	100-061-275	
4A0165		
4A0208	100-061-277	
4A0250	100-061-278	
4A0296		
4A0362	100-061-279	
4A0414		
4A0515	100-061-280	
4A0675		



Drive Model	Code Number	Figure
4A0930	100-061-281 <1>	<i>Figure D.10</i>
4A1200		
5A0041	100-061-274	<i>Figure D.9</i>
5A0052		
5A0062	100-061-275	
5A0077		
5A0099	100-061-277	
5A0125		
5A0145	100-061-278	
5A0192		
5A0242		

<1> Requires two sets.

**Note:** Model 4A1200 is UL compliant when the air entering the drive-installed panel or cabinet is 45 °C or cooler. For more information, contact your nearest Yaskawa representative or our sales office.

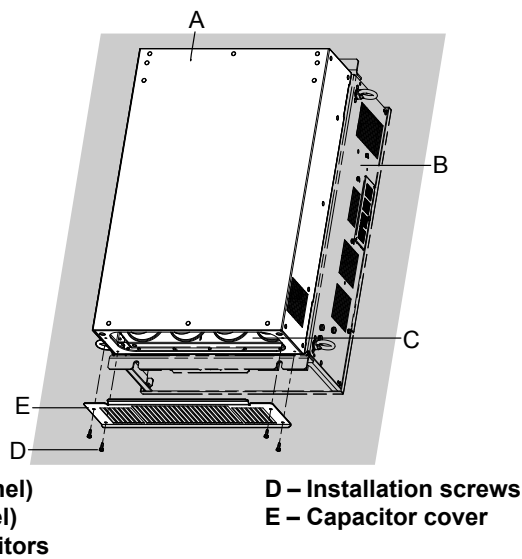

Figure D.9 Capacitor Cover

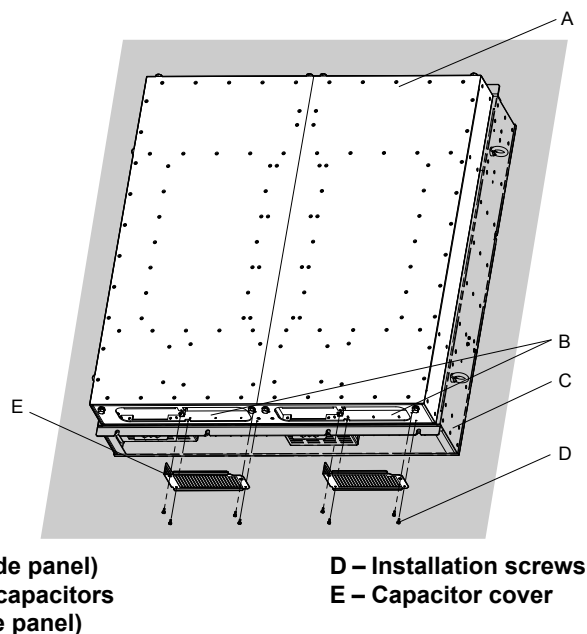

Figure D.10 Capacitor Cover (Models 4A0930, 4A1200)

## Revision History

The revision dates and the numbers of the revised manuals appear on the bottom of the back cover.

Example:

MANUAL NO. TOEP YAIP1W 01B <1>  
 └─ Revision number  
 Published in USA December 2013  
 └─ Date of publication

Date of Publication	Revision Number	Section	Revised Content
March 2017	<7>	Appendix: A	Revision: Added Single-Phase Main Circuit Wiring and Crimp Terminal Sizes.
		All	Revision: Reviewed and corrected documentation.
August 2016	<6>	All	Updated documentation to support drive software version PRG: 8554.
April 2016	<5>	All	Updated documentation to support drive software version PRG: 8553.
January 2016	<4>	Appendix: A	Revision: Single-Phase Derating
October 2015	<3>	All	Updated documentation to support drive software version PRG: 8552.
August 2015	<2>	All	Revision: Document title Revision: Changed UL enclosure type nomenclature Revision: Reviewed and corrected documentation
		Chapter 2	Revision: Removed 12-pulse model data and terminal wiring dimensions
		Chapter 3	Addition: Main circuit terminal configurations
December 2013	<1>	All	Updated documentation to support drive software version PRG: 8551. Addition: Added models 4A0930 and 4A1200. These models support drive software version PRG: 8550
		Appendix: C	Addition: Added MEMOBUS/Modbus Communication appendix.
November 2012	-	-	First Edition. This manual supports drive software version PRG: 8550.



# iQpump1000 AC Drive

## Intelligent Pump Controller

### User Manual

---

**YASKAWA AMERICA, INC.**

2121, Norman Drive South, Waukegan, IL 60085, U.S.A.  
Phone: 1-800-YASKAWA (927-5292) or 1-847-887-7000 Fax: 1-847-887-7310  
<http://www.yaskawa.com>

**DRIVE CENTER (INVERTER PLANT)**

2-13-1, Nishimiyaichi, Yukuhashi, Fukuoka, 824-8511, Japan  
Phone: 81-930-25-3844 Fax: 81-930-25-4369  
<http://www.yaskawa.co.jp>

**YASKAWA ELECTRIC CORPORATION**

New Pier Takeshiba South Tower, 1-16-1, Kaigan, Minatoku, Tokyo, 105-6891, Japan  
Phone: 81-3-5402-4502 Fax: 81-3-5402-4580  
<http://www.yaskawa.co.jp>

**YASKAWA ELÉTRICO DO BRASIL LTDA.**

777, Avenida Piraporinha, Diadema, São Paulo, 09950-000, Brasil  
Phone: 55-11-3585-1100 Fax: 55-11-3585-1187  
<http://www.yaskawa.com.br>

**YASKAWA EUROPE GmbH**

185, Hauptstraße, Eschborn, 65760, Germany  
Phone: 49-6196-569-300 Fax: 49-6196-569-398  
<http://www.yaskawa.eu.com>

**YASKAWA ELECTRIC KOREA CORPORATION**

9F, Kyobo Securities Bldg., 26-4, Yeouido-dong, Yeongdeungpo-gu, Seoul, 150-737, Korea  
Phone: 82-2-784-7844 Fax: 82-2-784-8495  
<http://www.yaskawa.co.kr>

**YASKAWA ELECTRIC (SINGAPORE) PTE. LTD.**

151, Lorong Chuan, #04-02A, New Tech Park, 556741, Singapore  
Phone: 65-6282-3003 Fax: 65-6289-3003  
<http://www.yaskawa.com.sg>

**YASKAWA ELECTRIC (THAILAND) CO., LTD.**

252/125-126, 27th Floor, Muang Thai-Phatra Tower B, Rachadapisek Road, Huaykwang, Bangkok, 10310, Thailand  
Phone: 66-2693-2200 Fax: 66-2693-4200  
<http://www.yaskawa.co.th>

**YASKAWA ELECTRIC (CHINA) CO., LTD.**

22F, One Corporate Avenue, No.222, Hubin Road, Shanghai, 200021, China  
Phone: 86-21-5385-2200 Fax: 86-21-5385-3299  
<http://www.yaskawa.com.cn>

**YASKAWA ELECTRIC (CHINA) CO., LTD. BEIJING OFFICE**

Room 1011, Tower W3 Oriental Plaza, No. 1, East Chang An Ave.,  
Dong Cheng District, Beijing, 100738, China  
Phone: 86-10-8518-4086 Fax: 86-10-8518-4082

**YASKAWA ELECTRIC TAIWAN CORPORATION**

9F, 16, Nanking E. Rd., Sec. 3, Taipei, 104, Taiwan  
Phone: 886-2-2502-5003 Fax: 886-2-2505-1280

**YASKAWA INDIA PRIVATE LIMITED**

#17/A, Electronics City, Hosur Road, Bangalore, 560 100 (Karnataka), India  
Phone: 91-80-4244-1900 Fax: 91-80-4244-1901  
<http://www.yaskawaindia.in>

---

**YASKAWA****YASKAWA AMERICA, INC.**

TOEPYAIP1W01

In the event that the end user of this product is to be the military and said product is to be employed in any weapons systems or the manufacture thereof, the export will fall under the relevant regulations as stipulated in the Foreign Exchange and Foreign Trade Regulations. Therefore, be sure to follow all procedures and submit all relevant documentation according to any and all rules, regulations and laws that may apply.

Specifications are subject to change without notice for ongoing product modifications and improvements.

© 2012-2017 YASKAWA AMERICA, INC.

MANUAL NO. TOEP YAIP1W 01F &lt;7&gt;

Published in USA March 2017